



FRIEDRICH

1 8 8 3

Endeavor® Line *F-Series* iR Packaged Air Conditioners



RACBZR

Cooling Efficiency: 13.4 SEER2
Nominal Sizes: 2-5 Tons [7-17.6 kW]



Table of Contents

Unit Features & Benefits.....	3-6
Model Number Identification.....	7
General Data	8-9
Gross Systems Performance Data.....	10-15
Indoor Airflow Performance.....	16-17
Electrical Data	18
Electric Heater Kits.....	19
Dimensional Data	20-21
Limited Warranty	24

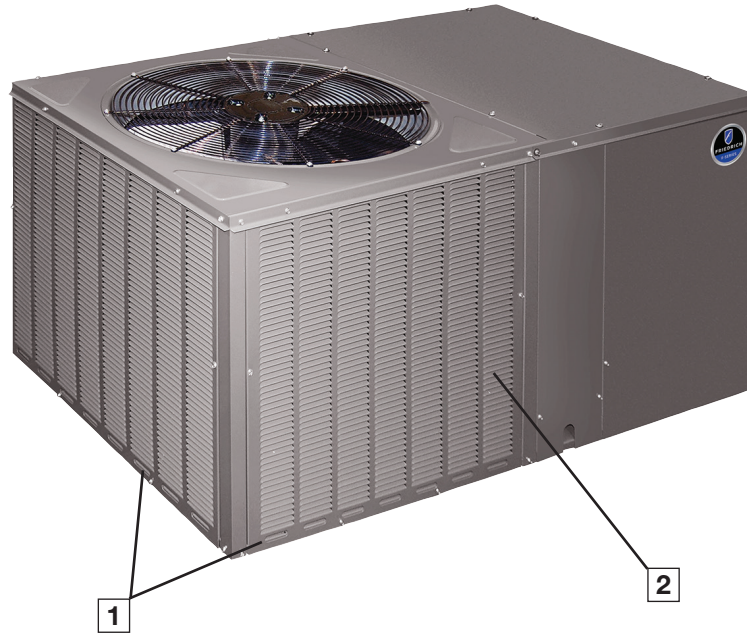

The RACB- series of Packaged Air Conditioners are designed to be the most efficient, quickest to install, easiest to service, and most reliable units in the industry — while still maintaining an affordable price. This platform provides you with a full line of nominal capacities from 2 through 5 tons utilizing earth-friendly R-410A refrigerant. This unit is suitable for use in mobile homes, manufactured housing and conventionally constructed residential and commercial buildings where horizontally-ducted systems are preferred. RACB models are 13.4 SEER2, each AHRI-certified.

Starting at the bottom, the base rails (1) allow for separation between the unit base and the ground level, protecting the base from ground moisture and providing air circulation around the unit. Constructed from sturdy 14-gauge G-90 sheet metal, the base rails also allow for easier maneuverability during installation.

As with all units offered by Friedrich®, we started our design process with input from the customer.

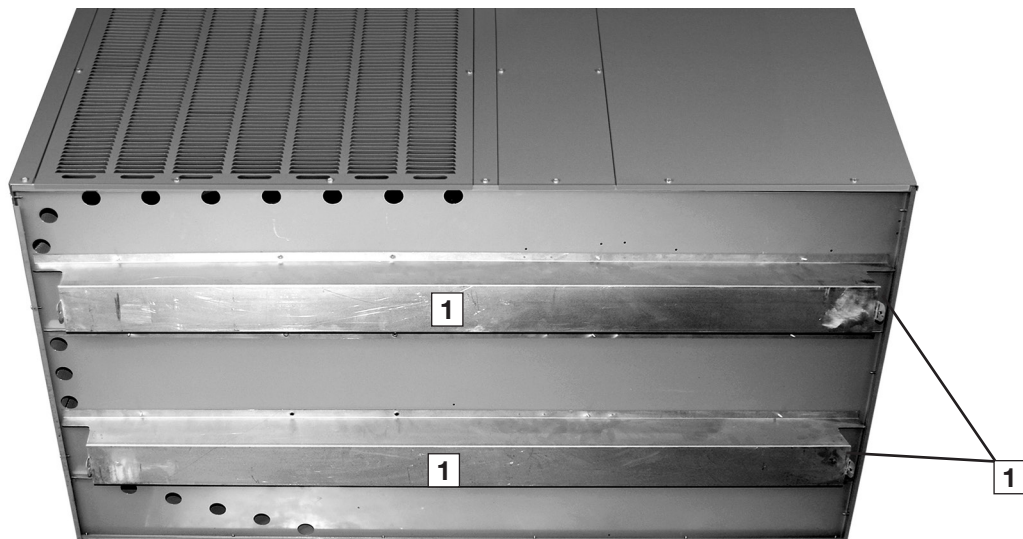

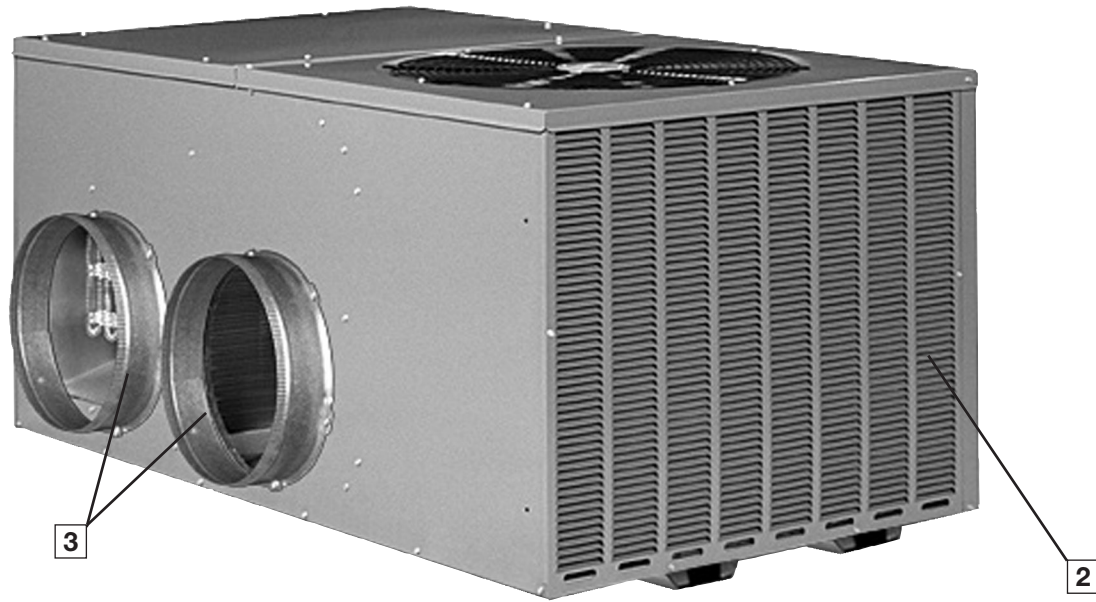

To provide flexibility in space-limited installations, the unit can be installed flush to the structure without blocking airflow over the outdoor coil or making any screws inaccessible for maintenance. Furthermore, the cabinet is a slim 33" wide.

MicroChannel Condenser Technology

The outdoor coil uses the latest microchannel technology (2) for the most effective method of heat transfer. The outdoor coil is protected by louvered panels, which allow unobstructed airflow while protecting the unit from both the environment and vandalism.

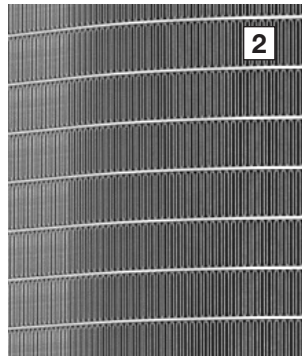

Two round 14" duct collar (3) are included with the unit, which makes attaching duct a snap. The collar is crimped around the leading edge, making it easier to install duct onto the collar. A metal bead around the circumference prevents the attached ducting from sliding off after installation.

Keeping service technicians in mind, Friedrich® takes pride providing easy access to internal components. The outdoor-section top cover (4) is easily removed to allow access to the scroll compressor (5), outdoor fan motor (6), and refrigerant tubing (7).

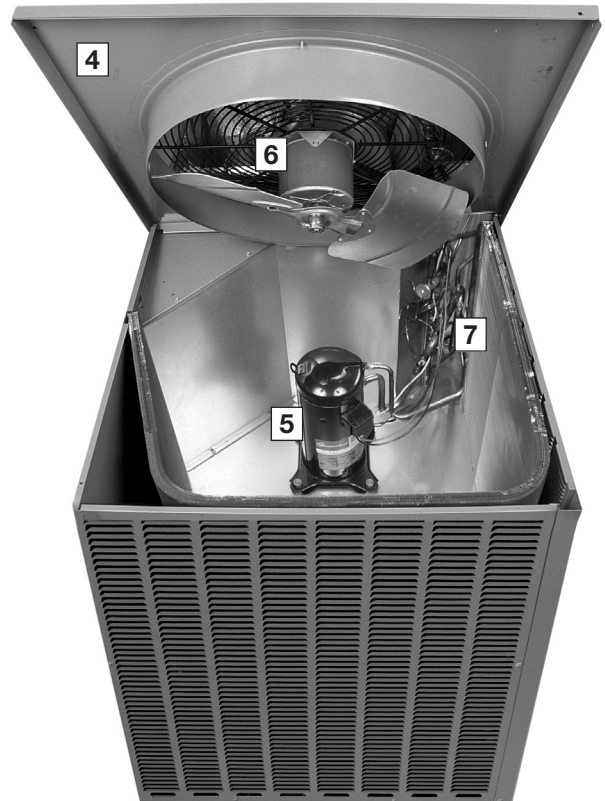

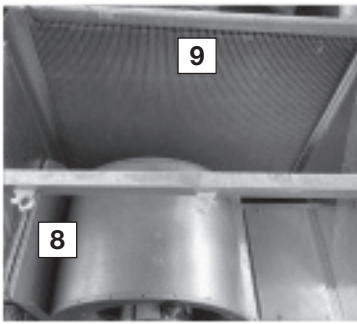

The indoor-section top cover also easily opens to access the removable blower housing and motor (8). This also gains total access to the indoor coil for cleaning and service (9).

MicroChannel Evaporator & TXV

The evaporator (9) uses microchannel technology for maximum heat transfer light weight, fewer manually brazed connections and reduced refrigerant charge. The TXV metering device maintains superheat over a wide range of varying temperatures optimizing unit performance for all conditions.

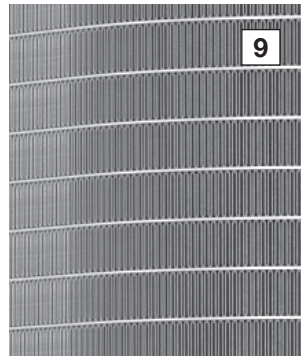

Optional electric heat (10) installed, or can be easily installed in the field, with either dual- or single-point power connections.

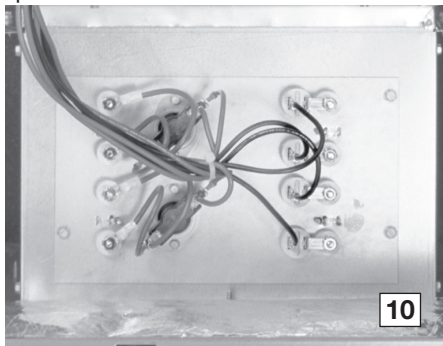

The controls are located in a large, easy-to-access control box (11), which provides plenty of space in which to troubleshoot. The transformer (12) is protected by an in-line fuse, which protects the transformer during a low-voltage electrical short. The low-voltage (13) and high-voltage (14) wiring connections are easily accessed and have ample room around which to maneuver. Troubleshooting is further aided with number- and color-coded wiring, which corresponds with the large, easy-to-read wiring diagram located on the inside of the control box access panel.

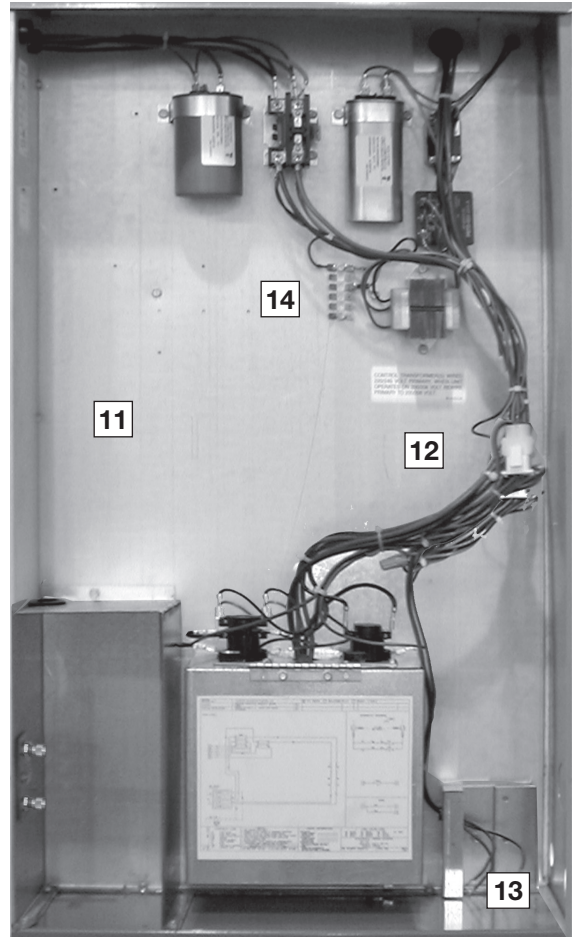

RACBZR

High and low refrigerant pressure can easily and accurately be measured using the two gauge ports (15) located inside the control box.

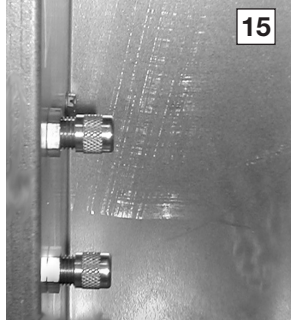

Foil-faced insulation is securely glued and captured to the cabinet. On the base of the unit, closed-cell insulation is used to prevent moisture from being absorbed and help reduce mold content to provide better indoor air quality.

A small side panel grants access to a removable, sloped drain pan (16), which helps to ensure indoor air quality (IAQ) through-out the life of the unit.

“Patent 7,430,877”



Air Conditioner

<u>R</u>	<u>AC</u>	<u>B</u>	<u>Z</u>	<u>R</u>	<u>024</u>	<u>A</u>	<u>J</u>	<u>T</u>	<u>00</u>	<u>0</u>	<u>N</u>	<u>A</u>
Brand	Product Category	Platform	Refrigerant	Tier	Capacity	Major Series	Voltage	Drive	Electric Heat	Electric Heat Configuration	Controls	Minor Series
R - Friedrich®	AC - Straight Cool	B - ResiPack Dedicated Horizontal	Z - R-410A	R - Base Tier (13.4 SEER2)	024 - 24,000 [7.03 kW] 030 - 30,000 [8.79 kW] 036 - 36,000 [10.55 kW] 042 - 42,000 [12.31 kW] 048 - 48,000 [14.07 kW] 060 - 60,000 [17.58 kW]	A - 1st Design	J - 1ph, 208-230/60	T - Constant Torque	00 - No Electric Heat	0 - No Electric Heat	N - Non-Communicating	A - 1st Design

[] Designates Metric Conversions

Available Models
RACBZR024AJT000NA
RACBZR030AJT000NA
RACBZR036AJT000NA
RACBZR042AJT000NA
RACBZR048AJT000NA
RACBZR060AJT000NA

NOMINAL SIZES 2-5 TON [7-17.6 kW]

Model RACBZR- Series	024AJT	030AJT	036AJT	042AJT
Cooling Performance¹				CONTINUED →
Gross Cooling Capacity Btu [kW]	24,000 [7.03]	29,200 [8.56]	36,600 [10.72]	41,500 [12.16]
EER2/SEER2 ²	10.6/13.4	10.6/13.4	10.6/13.4	10.6/13.4
Nominal CFM/AHRI Rated CFM [L/s]	800/800 [378/378]	1000/1000 [472/472]	1200/1200 [566/566]	1400/1400 [661/661]
AHRI Net Cooling Capacity Btu [kW]	23,000 [6.74]	28,000 [8.2]	35,200 [10.31]	40,000 [11.72]
Net Sensible Capacity Btu [kW]	15,500 [4.54]	18,000 [5.27]	25,200 [7.38]	28,700 [8.41]
Net Latent Capacity Btu [kW]	7,500 [2.2]	10,000 [2.93]	10,000 [2.93]	11,300 [3.31]
Net System Power [kW]	1.95	2.4	2.95	3.51
Compressor				
No./Type	1/Scroll	1/Scroll	1/Scroll	1/Scroll
Outdoor Sound Rating (dB)³				
	79	80	80	80
Outdoor Coil—Fin Type				
Tube Type	Louvered	Louvered	Louvered	Louvered
MicroChannel Depth in. [mm]	MicroChannel	MicroChannel	MicroChannel	MicroChannel
Face Area sq. ft. [sq. m]	0.472 [12]	0.4724395 [12]	0.4724395 [12]	0.4724395 [12]
Rows / FPI [FPcm]	10.1 [0.94]	12.36 [1.15]	12.36 [1.15]	12.36 [1.15]
	1 / 20 [8]	1 / 22 [9]	1 / 22 [9]	1 / 22 [9]
Indoor Coil—Fin Type				
Tube Type	Louvered	Louvered	Louvered	Louvered
MicroChannel Depth in. [mm]	MicroChannel	MicroChannel	MicroChannel	MicroChannel
Face Area sq. ft. [sq. m]	0.787 [20]	0.787399 [20]	1 [25.4]	1.25984 [32]
Rows / FPI [FPcm]	3.84 [0.36]	3.84 [0.36]	3.84 [0.36]	3.75 [0.35]
	1 / 15 [6]	1 / 15 [6]	1 / 15 [6]	1 / 13 [5]
Refrigerant Control	TX Valves	TX Valves	TX Valves	TX Valves
Drain Connection No./Size in. [mm]	1/1 [25.4]	1/1 [25.4]	1/1 [25.4]	1/1 [25.4]
Outdoor Fan—Type				
No. Used/Diameter in. [mm]	Propeller	Propeller	Propeller	Propeller
Drive Type/No. Speeds	1/24 [609.6]	1/24 [609.6]	1/24 [609.6]	1/24 [609.6]
CFM [L/s]	Direct/1	Direct/1	Direct/1	Direct/1
No. Motors/HP	3400 [1604]	3400 [1604]	3400 [1604]	3400 [1604]
Motor RPM	1 at 1/3 HP	1 at 1/3 HP	1 at 1/3 HP	1 at 1/3 HP
	825	825	825	825
Indoor Fan—Type				
No. Used/Diameter in. [mm]	FC Centrifugal	FC Centrifugal	FC Centrifugal	FC Centrifugal
Drive Type	1/10x9 [254x229]	1/10x9 [254x229]	1/10x9 [254x229]	1/11x9 [279x229]
No. Speeds	Direct	Direct	Direct	Direct
No. Motors	Multiple	Multiple	Multiple	Multiple
Motor HP	1	1	1	1
Motor RPM	1/2	1/2	1/2	3/4
Motor Frame Size	1050	1050	1050	1050
	48	48	48	48
Filter—Type				
Furnished	Field Supplied	Field Supplied	Field Supplied	Field Supplied
(NO.) Size Recommended in. [mm x mm x mm]	No	No	No	No
	(1)1x20x16 [25x508x406]	(1)1x20x20 [25x508x508]	(1)1x24x24 [25x610x610]	(1)1x24x24 [25x610x610]
Refrigerant Charge Oz. (Sys. 1/Sys. 2) [g]				
	50.72 [1438]	48 [1361]	53.44 [1515]	80 [2268]
Weights				
Net Weight lbs. [kg]	277 [126]	285 [129]	285 [129]	242 [110]
Ship Weight lbs. [kg]	304 [138]	312 [142]	312 [142]	269 [122]

[] Designates Metric Conversions

NOTES:

- Cooling Performance is rated at 95°F ambient, 80°F entering dry bulb, 67°F entering wet bulb. Gross capacity does not include the effect of fan motor heat. ARI capacity is net and includes the effect of fan motor heat. Units are suitable for operation to ±20% of nominal cfm. Units are certified in accordance with the Unitary Air Conditioner Equipment certification program, which is based on ARI Standard 210/240 or 360.
- EER2 and/or SEER2 are rated at ARI conditions and in accordance with DOE test procedures for 1-Phase models. EER and/or SEER are rated at ARI conditions and in accordance with DOE test procedures for 3-Phase models.
- Outdoor Sound Rating shown is tested in accordance with ARI Standard 270.

NOMINAL SIZES 2-5 TONS [7-17.6 kW]

Model RACBZR- Series	048AJT	060AJT
Cooling Performance¹	036AJT	042AJT
Gross Cooling Capacity Btu [kW]	49,000 [14.36]	60,000 [17.58]
EER2/SEER2 ²	10.6/13.4	10.6/13.4
Nominal CFM/AHRI Rated CFM [L/s]	1600/1600 [755/755]	2000/1900 [944/897]
AHRI Net Cooling Capacity Btu [kW]	47,000 [13.77]	57,000 [16.7]
Net Sensible Capacity Btu [kW]	32,500 [9.52]	40,100 [11.75]
Net Latent Capacity Btu [kW]	14,500 [4.25]	16,900 [4.95]
Net System Power [kW]	3.9	4.89
Compressor		
No./Type	1/Scroll	1/Scroll
Outdoor Sound Rating (dB)³	75	78
Outdoor Coil—Fin Type	Louvered	Louvered
Tube Type	MicroChannel	MicroChannel
MicroChannel Depth in. [mm]	0.6299 [16]	0.984 [25]
Face Area sq. ft. [sq. m]	16.14 [1.5]	16.19 [1.5]
Rows / FPI [FPcm]	1 / 22 [9]	1 / 22 [9]
Indoor Coil—Fin Type	Louvered	Louvered
Tube Type	MicroChannel	MicroChannel
MicroChannel Depth in. [mm]	1 [25.4]	1.25984 [32]
Face Area sq. ft. [sq. m]	5.3 [0.49]	5.3 [0.49]
Rows / FPI [FPcm]	1 / 13 [5]	1 / 13 [5]
Refrigerant Control	TX Valves	TX Valves
Drain Connection No./Size in. [mm]	1/1 [25.4]	1/1 [25.4]
Outdoor Fan—Type	Propeller	Propeller
No. Used/Diameter in. [mm]	1/24 [609.6]	1/24 [609.6]
Drive Type/No. Speeds	Direct/1	Direct/1
CFM [L/s]	4200 [1982]	4000 [1888]
No. Motors/HP	1 at 1/3 HP	1 at 1/3 HP
Motor RPM	1075	1075
Indoor Fan—Type	FC Centrifugal	FC Centrifugal
No. Used/Diameter in. [mm]	1/11x9 [279x229]	1/11x9 [279x229]
Drive Type	Direct	Direct
No. Speeds	Multiple	Multiple
No. Motors	1	1
Motor HP	3/4	1
Motor RPM	1050	1075
Motor Frame Size	48	48
Filter—Type	Field Supplied	Field Supplied
Furnished	No	No
(NO.) Size Recommended in. [mm x mm x mm]	(1)1x24x24 [25x610x610]	(1)1x24x24 [25x610x610]
Refrigerant Charge Oz. (Sys. 1/Sys. 2) [g]	64 [1814]	91.04 [2581]
Weights		
Net Weight lbs. [kg]	357 [162]	384 [174]
Ship Weight lbs. [kg]	384 [174]	411 [186]

[] Designates Metric Conversions

NOTES:

- Cooling Performance is rated at 95°F ambient, 80°F entering dry bulb, 67°F entering wet bulb. Gross capacity does not include the effect of fan motor heat. ARI capacity is net and includes the effect of fan motor heat. Units are suitable for operation to ±20% of nominal cfm. Units are certified in accordance with the Unitary Air Conditioner Equipment certification program, which is based on ARI Standard 210/240 or 360.
- EER2 and/or SEER2 are rated at ARI conditions and in accordance with DOE test procedures for 1-Phase models. EER and/or SEER are rated at ARI conditions and in accordance with DOE test procedures for 3-Phase models.
- Outdoor Sound Rating shown is tested in accordance with ARI Standard 270.

GROSS SYSTEMS PERFORMANCE DATA – RACBZR024AJT000NA

RACBZR024AJT000NA - ENTERING INDOOR AIR @ 80°F [26.7°C] dbE											
wbE		71°F [21.7°C]			67°F [19.4°C]			63°F [17.2°C]			
CFM [L/s]		925 [437]	800 [378]	675 [319]	925 [437]	800 [378]	675 [319]	925 [437]	800 [378]	675 [319]	
DR ①		.05	.09	.12	.05	.09	.12	.05	.09	.12	
OUTDOOR DRY BULB TEMPERATURE °F [°C]	75 [23.9]	Total BTUH [kW] Sens BTUH [kW] Power	30.0 [8.8] 16.9 [5.0] 1.6	29.2 [8.6] 15.8 [4.6] 1.6	28.4 [8.3] 14.6 [4.3] 1.5	27.7 [8.1] 19.4 [5.7] 1.6	27.0 [7.9] 18.1 [5.3] 1.6	26.2 [7.7] 16.7 [4.9] 1.5	25.4 [7.4] 21.2 [6.2] 1.6	24.7 [7.2] 19.7 [5.8] 1.6	24.0 [7.0] 18.3 [5.4] 1.6
	80 [26.7]	Total BTUH [kW] Sens BTUH [kW] Power	29.5 [8.6] 16.7 [4.9] 1.7	28.7 [8.4] 15.5 [4.5] 1.6	27.9 [8.2] 14.4 [4.2] 1.6	27.2 [8.0] 19.1 [5.6] 1.7	26.5 [7.8] 17.8 [5.2] 1.7	25.7 [7.5] 16.5 [4.8] 1.6	24.9 [7.3] 20.9 [6.1] 1.7	24.2 [7.1] 19.5 [5.7] 1.7	23.5 [6.9] 18.1 [5.3] 1.6
	85 [29.4]	Total BTUH [kW] Sens BTUH [kW] Power	28.9 [8.5] 16.4 [4.8] 1.8	28.1 [8.2] 15.3 [4.5] 1.7	27.3 [8.0] 14.2 [4.2] 1.7	26.6 [7.8] 18.9 [5.5] 1.8	25.9 [7.6] 17.6 [5.2] 1.7	25.1 [7.4] 16.3 [4.8] 1.7	24.3 [7.1] 20.7 [6.1] 1.8	23.6 [6.9] 19.3 [5.7] 1.7	22.9 [6.7] 17.9 [5.2] 1.7
	90 [32.2]	Total BTUH [kW] Sens BTUH [kW] Power	28.2 [8.3] 16.1 [4.7] 1.9	27.4 [8.0] 15.0 [4.4] 1.8	26.6 [7.8] 13.9 [4.1] 1.8	25.9 [7.6] 18.6 [5.5] 1.9	25.2 [7.4] 17.3 [5.1] 1.8	24.5 [7.2] 16.0 [4.7] 1.8	23.6 [6.9] 20.4 [6.0] 1.9	23.0 [6.7] 19.0 [5.6] 1.8	22.3 [6.5] 17.6 [5.2] 1.8
	95 [35]	Total BTUH [kW] Sens BTUH [kW] Power	27.4 [8.0] 15.8 [4.6] 2.0	26.7 [7.8] 14.7 [4.3] 1.9	25.9 [7.6] 13.6 [4.0] 1.9	25.2 [7.4] 18.2 [5.3] 2.0	24.5 [7.2] 17.0 [5.0] 1.9	23.8 [7.0] 15.7 [4.6] 1.9	22.9 [6.7] 20.0 [5.9] 2.0	22.2 [6.5] 18.7 [5.5] 2.0	21.6 [6.3] 17.3 [5.1] 1.9
	100 [37.8]	Total BTUH [kW] Sens BTUH [kW] Power	26.6 [7.8] 15.4 [4.5] 2.1	25.9 [7.6] 14.3 [4.2] 2.1	25.2 [7.4] 13.3 [3.9] 2.0	24.4 [7.2] 17.8 [5.2] 2.1	23.7 [6.9] 16.6 [4.9] 2.1	23.0 [6.7] 15.4 [4.5] 2.0	22.0 [6.4] 19.6 [5.7] 2.1	21.4 [6.3] 18.3 [5.4] 2.1	20.8 [6.1] 17.0 [5.0] 2.0
	105 [40.6]	Total BTUH [kW] Sens BTUH [kW] Power	25.7 [7.5] 15.0 [4.4] 2.2	25.0 [7.3] 14.0 [4.1] 2.2	24.3 [7.1] 12.9 [3.8] 2.1	23.5 [6.9] 17.4 [5.1] 2.2	22.8 [6.7] 16.2 [4.7] 2.2	22.2 [6.5] 15.1 [4.4] 2.1	21.2 [6.2] 19.2 [5.6] 2.2	20.6 [6.0] 17.9 [5.2] 2.2	20.0 [5.9] 16.6 [4.9] 2.2
	110 [43.3]	Total BTUH [kW] Sens BTUH [kW] Power	24.8 [7.3] 14.5 [4.2] 2.3	24.1 [7.1] 13.5 [4.0] 2.3	23.4 [6.9] 12.5 [3.7] 2.3	22.5 [6.6] 17.0 [5.0] 2.3	21.9 [6.4] 15.8 [4.6] 2.3	21.3 [6.2] 14.7 [4.3] 2.3	20.2 [5.9] 18.8 [5.5] 2.3	19.6 [5.7] 17.5 [5.1] 2.3	19.1 [5.6] 16.2 [4.7] 2.3
	115 [46.1]	Total BTUH [kW] Sens BTUH [kW] Power	23.8 [7.0] 14.0 [4.1] 2.5	23.1 [6.8] 13.1 [3.8] 2.4	22.5 [6.6] 12.1 [3.5] 2.4	21.5 [6.3] 16.5 [4.8] 2.5	20.9 [6.1] 15.4 [4.5] 2.4	20.3 [5.9] 14.3 [4.2] 2.4	19.2 [5.6] 18.3 [5.4] 2.5	18.7 [5.5] 17.1 [5.0] 2.4	18.1 [5.3] 15.8 [4.6] 2.4
	120 [48.9]	Total BTUH [kW] Sens BTUH [kW] Power	22.7 [6.7] 13.5 [4.0] 2.6	22.0 [6.4] 12.6 [3.7] 2.6	21.4 [6.3] 11.7 [3.4] 2.5	20.4 [6.0] 16 [4.7] 2.6	19.8 [5.8] 14.9 [4.4] 2.6	19.3 [5.7] 13.8 [4.0] 2.6	18.1 [5.3] 17.8 [5.2] 2.6	17.6 [5.2] 16.6 [4.9] 2.6	17.1 [5.0] 15.4 [4.5] 2.6
125 [51.7]	Total BTUH [kW] Sens BTUH [kW] Power	21.5 [6.3] 13.0 [3.8] 2.8	20.9 [6.1] 12.1 [3.5] 2.7	20.3 [5.9] 11.2 [3.3] 2.7	19.2 [5.6] 15.4 [4.5] 2.8	18.7 [5.5] 14.4 [4.2] 2.7	18.2 [5.3] 13.3 [3.9] 2.7	16.9 [5.0] 16.9 [5.0] 2.8	16.5 [4.8] 16.1 [4.7] 2.7	16.0 [4.7] 14.9 [4.4] 2.7	

DR —Depression ratio
 dbE —Entering air dry bulb
 wbE—Entering air wet bulb

Total —Total capacity x 1000 BTUH
 Sens —Sensible capacity x 1000 BTUH
 Power —KW input

NOTES: ① When the entering air dry bulb is other than 80°F [27°C], adjust the sensible capacity from the table by adding [1.10 x CFM x (1 – DR) x (dbE – 80)].

[] Designates Metric Conversions

GROSS SYSTEMS PERFORMANCE DATA – RACBZR030AJT000NA

RACBZR030AJT000NA - ENTERING INDOOR AIR @ 80°F [26.7°C] dbE											
wbE			71°F [21.7°C]			67°F [19.4°C]			63°F [17.2°C]		
CFM [L/s]			1075 [507]	1000 [472]	775 [366]	1075 [507]	1000 [472]	775 [366]	1075 [507]	1000 [472]	775 [366]
DR ①			.05	.09	.12	.05	.09	.12	.05	.09	.12
OUTDOOR DRY BULB TEMPERATURE °F [°C]	75 [23.9]	Total BTUH [kW] Sens BTUH [kW] Power	34.8 [10.2] 18.7 [5.5] 1.7	34.3 [10.1] 18.1 [5.3] 1.7	32.9 [9.6] 16.2 [4.7] 1.7	32.1 [9.4] 21.7 [6.4] 1.9	31.7 [9.3] 21.0 [6.2] 1.9	30.4 [8.9] 18.8 [5.5] 1.8	29.6 [8.7] 24.4 [7.2] 2.0	29.2 [8.6] 23.6 [6.9] 2.0	28.0 [8.2] 21.1 [6.2] 2.0
	80 [26.7]	Total BTUH [kW] Sens BTUH [kW] Power	34.0 [10.0] 18.4 [5.4] 1.9	33.6 [9.8] 17.8 [5.2] 1.9	32.2 [9.4] 15.9 [4.7] 1.9	31.4 [9.2] 21.4 [6.3] 2.1	31.0 [9.1] 20.7 [6.1] 2.1	29.7 [8.7] 18.5 [5.4] 2.0	28.9 [8.5] 24.1 [7.1] 2.2	28.5 [8.4] 23.3 [6.8] 2.2	27.3 [8.0] 20.9 [6.1] 2.2
	85 [29.4]	Total BTUH [kW] Sens BTUH [kW] Power	33.3 [9.8] 18.1 [5.3] 2.1	32.8 [9.6] 17.5 [5.1] 2.1	31.5 [9.2] 15.7 [4.6] 2.1	30.6 [9.0] 21.1 [6.2] 2.3	30.2 [8.9] 20.4 [6.0] 2.2	29.0 [8.5] 18.2 [5.3] 2.2	28.1 [8.2] 23.8 [7.0] 2.4	27.7 [8.1] 23.0 [6.7] 2.4	26.6 [7.8] 20.6 [6.0] 2.3
	90 [32.2]	Total BTUH [kW] Sens BTUH [kW] Power	32.5 [9.5] 17.8 [5.2] 2.3	32.0 [9.4] 17.2 [5.0] 2.3	30.7 [9.0] 15.4 [4.5] 2.2	29.8 [8.7] 20.8 [6.1] 2.4	29.4 [8.6] 20.1 [5.9] 2.4	28.2 [8.3] 18.0 [5.3] 2.4	27.3 [8.0] 23.5 [6.9] 2.6	26.9 [7.9] 22.7 [6.7] 2.6	25.8 [7.6] 20.3 [5.9] 2.5
	95 [35]	Total BTUH [kW] Sens BTUH [kW] Power	31.6 [9.3] 17.6 [5.2] 2.4	31.2 [9.1] 17.0 [5.0] 2.4	29.9 [8.8] 15.2 [4.5] 2.3	29.0 [8.5] 20.5 [6.0] 2.6	28.6 [8.4] 19.8 [5.8] 2.5	27.4 [8.0] 17.7 [5.2] 2.5	26.4 [7.7] 23.2 [6.8] 2.7	26.1 [7.6] 22.5 [6.6] 2.7	25.0 [7.3] 20.1 [5.9] 2.6
	100 [37.8]	Total BTUH [kW] Sens BTUH [kW] Power	30.8 [9.0] 17.3 [5.1] 2.5	30.4 [8.9] 16.7 [4.9] 2.5	29.1 [8.5] 15.0 [4.4] 2.5	28.1 [8.2] 20.2 [5.9] 2.7	27.7 [8.1] 19.6 [5.7] 2.7	26.6 [7.8] 17.5 [5.1] 2.6	25.6 [7.5] 23.0 [6.7] 2.8	25.2 [7.4] 22.2 [6.5] 2.8	24.2 [7.1] 19.9 [5.8] 2.7
	105 [40.6]	Total BTUH [kW] Sens BTUH [kW] Power	29.9 [8.8] 17.0 [5.0] 2.6	29.5 [8.6] 16.5 [4.8] 2.6	28.3 [8.3] 14.7 [4.3] 2.5	27.2 [8.0] 20.0 [5.9] 2.8	26.9 [7.9] 19.3 [5.7] 2.7	25.8 [7.6] 17.3 [5.1] 2.7	24.7 [7.2] 22.7 [6.7] 2.9	24.4 [7.2] 22.0 [6.4] 2.9	23.4 [6.9] 19.7 [5.8] 2.8
	110 [43.3]	Total BTUH [kW] Sens BTUH [kW] Power	29.0 [8.5] 16.8 [4.9] 2.7	28.6 [8.4] 16.2 [4.7] 2.6	27.4 [8.0] 14.5 [4.2] 2.6	26.3 [7.7] 19.7 [5.8] 2.8	26.0 [7.6] 19.1 [5.6] 2.8	24.9 [7.3] 17.1 [5.0] 2.7	23.8 [7.0] 22.5 [6.6] 3.0	23.5 [6.9] 21.7 [6.4] 2.9	22.5 [6.6] 19.4 [5.7] 2.9
	115 [46.1]	Total BTUH [kW] Sens BTUH [kW] Power	28.0 [8.2] 16.6 [4.9] 2.7	27.7 [8.1] 16.0 [4.7] 2.7	26.5 [7.8] 14.3 [4.2] 2.6	25.4 [7.4] 19.5 [5.7] 2.8	25.0 [7.3] 18.8 [5.5] 2.8	24.0 [7.0] 16.9 [5.0] 2.8	22.9 [6.7] 22.2 [6.5] 3.0	22.5 [6.6] 21.5 [6.3] 3.0	21.6 [6.3] 19.2 [5.6] 2.9
	120 [48.9]	Total BTUH [kW] Sens BTUH [kW] Power	27.1 [7.9] 16.3 [4.8] 2.7	26.7 [7.8] 15.8 [4.6] 2.7	25.6 [7.5] 14.1 [4.1] 2.6	24.4 [7.2] 19.3 [5.7] 2.9	24.1 [7.1] 18.6 [5.5] 2.8	23.1 [6.8] 16.7 [4.9] 2.8	21.9 [6.4] 21.9 [6.4] 3.0	21.6 [6.3] 21.3 [6.2] 3.0	20.7 [6.1] 19.0 [5.6] 2.9
125 [51.7]	Total BTUH [kW] Sens BTUH [kW] Power	26.1 [7.6] 16.1 [4.7] 2.7	25.7 [7.5] 15.6 [4.6] 2.7	24.7 [7.2] 13.9 [4.1] 2.6	23.4 [6.9] 19.1 [5.6] 2.8	23.1 [6.8] 18.4 [5.4] 2.8	22.2 [6.5] 16.5 [4.8] 2.8	20.9 [6.1] 20.9 [6.1] 3.0	20.6 [6.0] 20.6 [6.0] 3.0	19.8 [5.8] 18.9 [5.5] 2.9	

DR —Depression ratio
dbE —Entering air dry bulb
wbE—Entering air wet bulb

Total —Total capacity x 1000 BTUH
Sens —Sensible capacity x 1000 BTUH
Power —KW input

NOTES: ① When the entering air dry bulb is other than 80°F [27°C], adjust the sensible capacity from the table by adding $[1.10 \times \text{CFM} \times (1 - \text{DR}) \times (\text{dbE} - 80)]$.

[] Designates Metric Conversions

GROSS SYSTEMS PERFORMANCE DATA – RACBZR036AJT000NA

RACBZR036AJT000NA - ENTERING INDOOR AIR @ 80°F [26.7°C] dbE											
wbE		71°F [21.7°C]			67°F [19.4°C]			63°F [17.2°C]			
CFM [L/s]		1325 [625]	1200 [566]	950 [448]	1325 [625]	1200 [566]	950 [448]	1325 [625]	1200 [566]	950 [448]	
DR ①		.05	.09	.12	.05	.09	.12	.05	.09	.12	
OUTDOOR DRY BULB TEMPERATURE °F [°C]	75 [23.9]	Total BTUH [kW] Sens BTUH [kW] Power	44.2 [13.0] 25.7 [7.5] 2.5	43.4 [12.7] 24.5 [7.2] 2.4	41.7 [12.2] 22.1 [6.5] 2.4	41.1 [12.0] 29.5 [8.6] 2.4	40.4 [11.8] 28.2 [8.3] 2.4	38.8 [11.4] 25.4 [7.4] 2.4	38.1 [11.2] 32.5 [9.5] 2.4	37.4 [11.0] 31.0 [9.1] 2.4	36.0 [10.6] 28.0 [8.2] 2.4
	80 [26.7]	Total BTUH [kW] Sens BTUH [kW] Power	42.9 [12.6] 25.0 [7.3] 2.6	42.1 [12.3] 23.9 [7.0] 2.5	40.5 [11.9] 21.5 [6.3] 2.5	39.9 [11.7] 28.8 [8.4] 2.6	39.1 [11.5] 27.5 [8.1] 2.5	37.6 [11.0] 24.8 [7.3] 2.5	36.8 [10.8] 31.8 [9.3] 2.5	36.1 [10.6] 30.4 [8.9] 2.5	34.8 [10.2] 27.4 [8.0] 2.5
	85 [29.4]	Total BTUH [kW] Sens BTUH [kW] Power	41.6 [12.2] 24.3 [7.1] 2.7	40.9 [12.0] 23.2 [6.8] 2.7	39.3 [11.5] 20.9 [6.1] 2.6	38.6 [11.3] 28.1 [8.2] 2.7	37.9 [11.1] 26.8 [7.9] 2.7	36.4 [10.7] 24.2 [7.1] 2.6	35.5 [10.4] 31.2 [9.1] 2.7	34.9 [10.2] 29.7 [8.7] 2.6	33.5 [9.8] 26.8 [7.9] 2.6
	90 [32.2]	Total BTUH [kW] Sens BTUH [kW] Power	40.4 [11.8] 23.6 [6.9] 2.8	39.6 [11.6] 22.5 [6.6] 2.8	38.1 [11.2] 20.3 [5.9] 2.8	37.3 [10.9] 27.4 [8.0] 2.8	36.6 [10.7] 26.2 [7.7] 2.8	35.2 [10.3] 23.6 [6.9] 2.7	34.3 [10.1] 30.5 [8.9] 2.8	33.6 [9.8] 29.0 [8.5] 2.8	32.3 [9.5] 26.2 [7.7] 2.7
	95 [35]	Total BTUH [kW] Sens BTUH [kW] Power	39.1 [11.5] 22.9 [6.7] 3.0	38.4 [11.3] 21.9 [6.4] 3.0	36.9 [10.8] 19.7 [5.8] 2.9	36 [10.6] 26.8 [7.9] 3.0	35.4 [10.4] 25.5 [7.5] 2.9	34.0 [10.0] 23.0 [6.7] 2.9	33.0 [9.7] 29.8 [8.7] 3.0	32.4 [9.5] 28.4 [8.3] 2.9	31.1 [9.1] 25.6 [7.5] 2.9
	100 [37.8]	Total BTUH [kW] Sens BTUH [kW] Power	37.8 [11.1] 22.2 [6.5] 3.2	37.1 [10.9] 21.2 [6.2] 3.1	35.7 [10.5] 19.1 [5.6] 3.1	34.8 [10.2] 26.1 [7.6] 3.1	34.1 [10.0] 24.8 [7.3] 3.1	32.8 [9.6] 22.4 [6.6] 3.1	31.7 [9.3] 29.1 [8.5] 3.1	31.1 [9.1] 27.7 [8.1] 3.1	29.9 [8.8] 25.0 [7.3] 3.0
	105 [40.6]	Total BTUH [kW] Sens BTUH [kW] Power	36.5 [10.7] 21.5 [6.3] 3.3	35.9 [10.5] 20.5 [6.0] 3.3	34.5 [10.1] 18.5 [5.4] 3.2	33.5 [9.8] 25.4 [7.4] 3.3	32.9 [9.6] 24.2 [7.1] 3.3	31.6 [9.3] 21.8 [6.4] 3.2	30.4 [8.9] 28.4 [8.3] 3.3	29.9 [8.8] 27.1 [7.9] 3.3	28.7 [8.4] 24.4 [7.2] 3.2
	110 [43.3]	Total BTUH [kW] Sens BTUH [kW] Power	35.3 [10.3] 20.8 [6.1] 3.5	34.6 [10.1] 19.9 [5.8] 3.5	33.3 [9.8] 17.9 [5.2] 3.4	32.2 [9.4] 24.7 [7.2] 3.5	31.6 [9.3] 23.5 [6.9] 3.5	30.4 [8.9] 21.2 [6.2] 3.4	29.1 [8.5] 27.7 [8.1] 3.5	28.6 [8.4] 26.4 [7.7] 3.5	27.5 [8.1] 23.8 [7.0] 3.4
	115 [46.1]	Total BTUH [kW] Sens BTUH [kW] Power	34.0 [10.0] 20.2 [5.9] 3.7	33.4 [9.8] 19.2 [5.6] 3.7	32.1 [9.4] 17.3 [5.1] 3.6	30.9 [9.1] 24.0 [7.0] 3.7	30.4 [8.9] 22.9 [6.7] 3.7	29.2 [8.6] 20.6 [6.0] 3.6	27.9 [8.2] 27.0 [7.9] 3.7	27.4 [8.0] 25.7 [7.5] 3.7	26.3 [7.7] 23.2 [6.8] 3.6
	120 [48.9]	Total BTUH [kW] Sens BTUH [kW] Power	32.7 [9.6] 19.5 [5.7] 3.9	32.1 [9.4] 18.6 [5.5] 3.9	30.9 [9.1] 16.7 [4.9] 3.8	29.7 [8.7] 23.3 [6.8] 3.9	29.1 [8.5] 22.2 [6.5] 3.9	28.0 [8.2] 20.0 [5.9] 3.8	26.6 [7.8] 26.3 [7.7] 3.9	26.1 [7.6] 25.1 [7.4] 3.9	25.1 [7.4] 22.6 [6.6] 3.8
	125 [51.7]	Total BTUH [kW] Sens BTUH [kW] Power	31.4 [9.2] 18.8 [5.5] 4.1	30.8 [9.0] 17.9 [5.2] 4.1	29.7 [8.7] 16.1 [4.7] 4.0	28.4 [8.3] 22.6 [6.6] 4.1	27.8 [8.1] 21.5 [6.3] 4.1	26.8 [7.9] 19.4 [5.7] 4.0	25.3 [7.4] 25.3 [7.4] 4.1	24.8 [7.3] 24.4 [7.2] 4.1	23.9 [7.0] 22.0 [6.4] 4.0

DR —Depression ratio
 dbE —Entering air dry bulb
 wbE—Entering air wet bulb

Total —Total capacity x 1000 BTUH
 Sens —Sensible capacity x 1000 BTUH
 Power —KW input

NOTES: ① When the entering air dry bulb is other than 80°F [27°C], adjust the sensible capacity from the table by adding $[1.10 \times \text{CFM} \times (1 - \text{DR}) \times (\text{dbE} - 80)]$.

[] Designates Metric Conversions

GROSS SYSTEMS PERFORMANCE DATA – RACBZR042AJT000NA

RACBZR042AJT000NA - ENTERING INDOOR AIR @ 80°F [26.7°C] dbE											
wbE		71°F [21.7°C]			67°F [19.4°C]			63°F [17.2°C]			
CFM [L/s]		1500 [708]	1400 [661]	1100 [519]	1500 [708]	1400 [661]	1100 [519]	1500 [708]	1400 [661]	1100 [519]	
DR ①		.05	.09	.12	.05	.09	.12	.05	.09	.12	
OUTDOOR DRY BULB TEMPERATURE °F [°C]	75 [23.9]	Total BTUH [kW] Sens BTUH [kW] Power	49.4 [14.5] 27.9 [8.2] 2.9	48.7 [14.3] 27.0 [7.9] 2.9	46.8 [13.7] 24.3 [7.1] 2.9	46.2 [13.5] 32.7 [9.6] 2.9	45.6 [13.4] 31.7 [9.3] 2.9	43.9 [12.9] 28.5 [8.4] 2.8	43.3 [12.7] 37.4 [11.0] 2.9	42.7 [12.5] 36.2 [10.6] 2.9	41.1 [12.0] 32.6 [9.6] 2.8
	80 [26.7]	Total BTUH [kW] Sens BTUH [kW] Power	48.0 [14.1] 27.1 [7.9] 3.1	47.4 [13.9] 26.2 [7.7] 3.0	45.6 [13.4] 23.6 [6.9] 3.0	44.9 [13.2] 31.9 [9.3] 3.0	44.3 [13.0] 30.9 [9.1] 3.0	42.6 [12.5] 27.8 [8.1] 3.0	42.0 [12.3] 36.6 [10.7] 3.0	41.4 [12.1] 35.4 [10.4] 3.0	39.8 [11.7] 31.9 [9.3] 3.0
	85 [29.4]	Total BTUH [kW] Sens BTUH [kW] Power	46.7 [13.7] 26.3 [7.7] 3.2	46.1 [13.5] 25.5 [7.5] 3.2	44.3 [13.0] 22.9 [6.7] 3.1	43.5 [12.7] 31.2 [9.1] 3.2	43.0 [12.6] 30.1 [8.8] 3.2	41.3 [12.1] 27.1 [7.9] 3.1	40.6 [11.9] 35.8 [10.5] 3.2	40.1 [11.8] 34.6 [10.1] 3.2	38.5 [11.3] 31.2 [9.1] 3.1
	90 [32.2]	Total BTUH [kW] Sens BTUH [kW] Power	45.3 [13.3] 25.5 [7.5] 3.4	44.7 [13.1] 24.7 [7.2] 3.4	43.0 [12.6] 22.2 [6.5] 3.3	42.1 [12.3] 30.4 [8.9] 3.4	41.6 [12.2] 29.4 [8.6] 3.3	40.0 [11.7] 26.5 [7.8] 3.3	39.2 [11.5] 35.0 [10.3] 3.3	38.7 [11.3] 33.9 [9.9] 3.3	37.2 [10.9] 30.5 [8.9] 3.3
	95 [35]	Total BTUH [kW] Sens BTUH [kW] Power	43.9 [12.9] 24.7 [7.2] 3.6	43.3 [12.7] 23.9 [7.0] 3.5	41.6 [12.2] 21.6 [6.3] 3.5	40.7 [11.9] 29.6 [8.7] 3.5	40.2 [11.8] 28.6 [8.4] 3.5	38.6 [11.3] 25.8 [7.6] 3.5	37.8 [11.1] 34.2 [10.0] 3.5	37.3 [10.9] 33.1 [9.7] 3.5	35.9 [10.5] 29.8 [8.7] 3.4
	100 [37.8]	Total BTUH [kW] Sens BTUH [kW] Power	42.4 [12.4] 24.0 [7.0] 3.8	41.9 [12.3] 23.2 [6.8] 3.7	40.2 [11.8] 20.9 [6.1] 3.7	39.3 [11.5] 28.8 [8.4] 3.7	38.8 [11.4] 27.9 [8.2] 3.7	37.3 [10.9] 25.1 [7.4] 3.6	36.4 [10.7] 33.4 [9.8] 3.7	35.9 [10.5] 32.4 [9.5] 3.7	34.5 [10.1] 29.1 [8.5] 3.6
	105 [40.6]	Total BTUH [kW] Sens BTUH [kW] Power	41.0 [12.0] 23.2 [6.8] 3.9	40.4 [11.8] 22.5 [6.6] 3.9	38.9 [11.4] 20.2 [5.9] 3.9	37.8 [11.1] 28.1 [8.2] 3.9	37.3 [10.9] 27.2 [8.0] 3.9	35.9 [10.5] 24.4 [7.2] 3.8	34.9 [10.2] 32.7 [9.6] 3.9	34.4 [10.1] 31.6 [9.3] 3.9	33.1 [9.7] 28.5 [8.4] 3.8
	110 [43.3]	Total BTUH [kW] Sens BTUH [kW] Power	39.5 [11.6] 22.5 [6.6] 4.2	39.0 [11.4] 21.7 [6.4] 4.1	37.4 [11.0] 19.6 [5.7] 4.1	36.3 [10.6] 27.3 [8.0] 4.1	35.9 [10.5] 26.4 [7.7] 4.1	34.5 [10.1] 23.8 [7.0] 4.0	33.4 [9.8] 31.9 [9.3] 4.1	33.0 [9.7] 30.9 [9.1] 4.1	31.7 [9.3] 27.8 [8.1] 4.0
	115 [46.1]	Total BTUH [kW] Sens BTUH [kW] Power	37.9 [11.1] 21.7 [6.4] 4.4	37.4 [11] 21.0 [6.2] 4.3	36.0 [10.6] 18.9 [5.5] 4.3	34.8 [10.2] 26.6 [7.8] 4.4	34.3 [10.1] 25.7 [7.5] 4.3	33.0 [9.7] 23.1 [6.8] 4.2	31.9 [9.3] 31.2 [9.1] 4.3	31.5 [9.2] 30.2 [8.9] 4.3	30.2 [8.9] 27.2 [8.0] 4.2
	120 [48.9]	Total BTUH [kW] Sens BTUH [kW] Power	36.4 [10.7] 21.0 [6.2] 4.6	35.9 [10.5] 20.3 [5.9] 4.6	34.5 [10.1] 18.3 [5.4] 4.5	33.2 [9.7] 25.8 [7.6] 4.6	32.8 [9.6] 25.0 [7.3] 4.6	31.5 [9.2] 22.5 [6.6] 4.5	30.3 [8.9] 30.3 [8.9] 4.6	29.9 [8.8] 29.5 [8.6] 4.5	28.8 [8.4] 26.5 [7.8] 4.4
	125 [51.7]	Total BTUH [kW] Sens BTUH [kW] Power	34.8 [10.2] 20.3 [5.9] 4.8	34.4 [10.1] 19.6 [5.7] 4.8	33.0 [9.7] 17.6 [5.2] 4.7	31.7 [9.3] 25.1 [7.4] 4.8	31.3 [9.2] 24.3 [7.1] 4.8	30.0 [8.8] 21.9 [6.4] 4.7	28.7 [8.4] 28.7 [8.4] 4.8	28.4 [8.3] 28.4 [8.3] 4.8	27.3 [8.0] 25.9 [7.6] 4.7

DR —Depression ratio
dbE —Entering air dry bulb
wbE—Entering air wet bulb

Total —Total capacity x 1000 BTUH
Sens —Sensible capacity x 1000 BTUH
Power —KW input

NOTES: ① When the entering air dry bulb is other than 80°F [27°C], adjust the sensible capacity from the table by adding [1.10 x CFM x (1 – DR) x (dbE – 80)].

[] Designates Metric Conversions

GROSS SYSTEMS PERFORMANCE DATA – RACBZR048AJT000NA

RACBZR048AJT000NA - ENTERING INDOOR AIR @ 80°F [26.7°C] dbE											
wbE		71°F [21.7°C]			67°F [19.4°C]			63°F [17.2°C]			
CFM [L/s]		1775 [838]	1600 [755]	1275 [602]	1775 [838]	1600 [755]	1275 [602]	1775 [838]	1600 [755]	1275 [602]	
DR ①		.05	.09	.12	.05	.09	.12	.05	.09	.12	
OUTDOOR DRY BULB TEMPERATURE °F [°C]	75 [23.9]	Total BTUH [kW] Sens BTUH [kW] Power	58.1 [17.0] 33.6 [9.8] 3.2	57.0 [16.7] 32.0 [9.4] 3.2	54.9 [16.1] 29.0 [8.5] 3.2	54.7 [16.0] 38.4 [11.3] 3.2	53.6 [15.7] 36.5 [10.7] 3.2	51.6 [15.1] 33.1 [9.7] 3.1	51.1 [15.0] 43.3 [12.7] 3.2	50.1 [14.7] 41.2 [12.1] 3.2	48.2 [14.1] 37.3 [10.9] 3.1
	80 [26.7]	Total BTUH [kW] Sens BTUH [kW] Power	56.6 [16.6] 31.9 [9.3] 3.4	55.5 [16.3] 30.3 [8.9] 3.4	53.4 [15.7] 27.5 [8.1] 3.3	53.1 [15.6] 36.7 [10.8] 3.4	52.1 [15.3] 34.9 [10.2] 3.4	50.2 [14.7] 31.6 [9.3] 3.3	49.5 [14.5] 41.6 [12.2] 3.4	48.6 [14.2] 39.5 [11.6] 3.3	46.8 [13.7] 35.8 [10.5] 3.3
	85 [29.4]	Total BTUH [kW] Sens BTUH [kW] Power	55.0 [16.1] 30.6 [9.0] 3.6	54.0 [15.8] 29.1 [8.5] 3.5	52.0 [15.2] 26.3 [7.7] 3.5	51.6 [15.1] 35.3 [10.3] 3.6	50.6 [14.8] 33.6 [9.8] 3.5	48.7 [14.3] 30.4 [8.9] 3.5	48.0 [14.1] 40.2 [11.8] 3.5	47.1 [13.8] 38.3 [11.2] 3.5	45.3 [13.3] 34.7 [10.2] 3.4
	90 [32.2]	Total BTUH [kW] Sens BTUH [kW] Power	53.5 [15.7] 29.6 [8.7] 3.8	52.4 [15.4] 28.2 [8.3] 3.7	50.5 [14.8] 25.5 [7.5] 3.6	50.0 [14.7] 34.4 [10.1] 3.7	49.1 [14.4] 32.7 [9.6] 3.7	47.2 [13.8] 29.6 [8.7] 3.6	46.4 [13.6] 39.3 [11.5] 3.7	45.5 [13.3] 37.4 [11.0] 3.7	43.8 [12.8] 33.9 [9.9] 3.6
	95 [35]	Total BTUH [kW] Sens BTUH [kW] Power	51.9 [15.2] 29.1 [8.5] 3.9	50.8 [14.9] 27.7 [8.1] 3.9	49.0 [14.4] 25.1 [7.4] 3.8	48.4 [14.2] 33.9 [9.9] 3.9	47.5 [13.9] 32.2 [9.4] 3.9	45.7 [13.4] 29.2 [8.6] 3.8	44.8 [13.1] 38.8 [11.4] 3.9	43.9 [12.9] 36.9 [10.8] 3.9	42.3 [12.4] 33.4 [9.8] 3.8
	100 [37.8]	Total BTUH [kW] Sens BTUH [kW] Power	50.2 [14.7] 29.0 [8.5] 4.1	49.2 [14.4] 27.6 [8.1] 4.1	47.4 [13.9] 24.9 [7.3] 4.0	46.8 [13.7] 33.7 [9.9] 4.1	45.9 [13.5] 32.1 [9.4] 4.1	44.2 [13.0] 29.0 [8.5] 4.0	43.2 [12.7] 38.6 [11.3] 4.1	42.3 [12.4] 36.7 [10.8] 4.1	40.8 [12.0] 33.3 [9.8] 4.0
	105 [40.6]	Total BTUH [kW] Sens BTUH [kW] Power	48.6 [14.2] 29.2 [8.6] 4.4	47.6 [14.0] 27.8 [8.1] 4.3	45.9 [13.5] 25.2 [7.4] 4.2	45.1 [13.2] 34.0 [10.0] 4.4	44.3 [13.0] 32.3 [9.5] 4.3	42.6 [12.5] 29.3 [8.6] 4.2	41.5 [12.2] 38.9 [11.4] 4.3	40.7 [11.9] 37.0 [10.8] 4.3	39.2 [11.5] 33.5 [9.8] 4.2
	110 [43.3]	Total BTUH [kW] Sens BTUH [kW] Power	46.9 [13.7] 29.9 [8.8] 4.6	46.0 [13.5] 28.4 [8.3] 4.5	44.3 [13.0] 25.7 [7.5] 4.5	43.5 [12.7] 34.6 [10.1] 4.6	42.6 [12.5] 32.9 [9.6] 4.5	41.0 [12.0] 29.8 [8.7] 4.5	39.9 [11.7] 39.5 [11.6] 4.6	39.1 [11.5] 37.6 [11.0] 4.5	37.6 [11.0] 34.0 [10.0] 4.4
	115 [46.1]	Total BTUH [kW] Sens BTUH [kW] Power	45.2 [13.2] 30.9 [9.1] 4.8	44.3 [13.0] 29.4 [8.6] 4.8	42.7 [12.5] 26.6 [7.8] 4.7	41.8 [12.3] 35.7 [10.5] 4.8	40.9 [12.0] 33.9 [9.9] 4.8	39.4 [11.5] 30.7 [9.0] 4.7	38.1 [11.2] 38.1 [11.2] 4.8	37.4 [11.0] 37.4 [11.0] 4.8	36.0 [10.6] 34.9 [10.2] 4.7
	120 [48.9]	Total BTUH [kW] Sens BTUH [kW] Power	43.4 [12.7] 32.3 [9.5] 5.1	42.6 [12.5] 30.7 [9.0] 5.0	41.0 [12.0] 27.8 [8.1] 4.9	40.0 [11.7] 37.1 [10.9] 5.1	39.2 [11.5] 35.3 [10.3] 5.0	37.8 [11.1] 31.9 [9.3] 4.9	36.4 [10.7] 36.4 [10.7] 5.1	35.7 [10.5] 35.7 [10.5] 5.0	34.4 [10.1] 34.4 [10.1] 4.9
	125 [51.7]	Total BTUH [kW] Sens BTUH [kW] Power	41.7 [12.2] 34.1 [10.0] 5.3	40.9 [12.0] 32.5 [9.5] 5.3	39.4 [11.5] 29.4 [8.6] 5.2	38.2 [11.2] 38.2 [11.2] 5.3	37.5 [11.0] 37.0 [10.8] 5.3	36.1 [10.6] 33.5 [9.8] 5.2	34.6 [10.1] 34.6 [10.1] 5.3	34.0 [10.0] 34.0 [10.0] 5.3	32.7 [9.6] 32.7 [9.6] 5.2

DR —Depression ratio
 dbE —Entering air dry bulb
 wbE—Entering air wet bulb

Total —Total capacity x 1000 BTUH
 Sens —Sensible capacity x 1000 BTUH
 Power —KW input

NOTES: ① When the entering air dry bulb is other than 80°F [27°C], adjust the sensible capacity from the table by adding [1.10 x CFM x (1 – DR) x (dbE – 80)].

[] Designates Metric Conversions

GROSS SYSTEMS PERFORMANCE DATA – RACBZR060AJT000NA

RACBZR060AJT000NA - ENTERING INDOOR AIR @ 80°F [26.7°C] dbE											
wbE			71°F [21.7°C]			67°F [19.4°C]			63°F [17.2°C]		
CFM [L/s]			2125 [1003]	1900 [897]	1550 [732]	2125 [1003]	1900 [897]	1550 [732]	2125 [1003]	1900 [897]	1550 [732]
DR ①			.05	.09	.12	.05	.09	.12	.05	.09	.12
OUTDOOR DRY BULB TEMPERATURE °F [°C]	75 [23.9]	Total BTUH [kW] Sens BTUH [kW] Power	69.8 [20.5] 39.4 [11.5] 4.1	68.4 [20.0] 37.4 [11.0] 4.1	66.1 [19.4] 34.2 [10.0] 4.0	64.8 [19.0] 45.6 [13.4] 4.1	63.4 [18.6] 43.2 [12.7] 4.1	61.3 [18.0] 39.5 [11.6] 4.0	60.1 [17.6] 50.7 [14.9] 4.1	58.8 [17.2] 48.1 [14.1] 4.0	56.9 [16.7] 43.9 [12.9] 4.0
	80 [26.7]	Total BTUH [kW] Sens BTUH [kW] Power	68.3 [20.0] 38.6 [11.3] 4.3	66.9 [19.6] 36.6 [10.7] 4.3	64.6 [18.9] 33.5 [9.8] 4.2	63.3 [18.6] 44.8 [13.1] 4.3	61.9 [18.1] 42.5 [12.5] 4.2	59.9 [17.6] 38.8 [11.4] 4.2	58.6 [17.2] 49.9 [14.6] 4.3	57.3 [16.8] 47.3 [13.9] 4.2	55.4 [16.2] 43.2 [12.7] 4.2
	85 [29.4]	Total BTUH [kW] Sens BTUH [kW] Power	66.7 [19.5] 37.8 [11.1] 4.5	65.3 [19.1] 35.8 [10.5] 4.5	63.1 [18.5] 32.7 [9.6] 4.4	61.6 [18.1] 44.0 [12.9] 4.5	60.3 [17.7] 41.7 [12.2] 4.5	58.3 [17.1] 38.1 [11.2] 4.4	56.9 [16.7] 49.1 [14.4] 4.5	55.7 [16.3] 46.5 [13.6] 4.4	53.9 [15.8] 42.5 [12.5] 4.4
	90 [32.2]	Total BTUH [kW] Sens BTUH [kW] Power	65.0 [19.1] 36.8 [10.8] 4.7	63.6 [18.6] 34.9 [10.2] 4.7	61.5 [18.0] 31.9 [9.3] 4.6	59.9 [17.6] 43.0 [12.6] 4.7	58.6 [17.2] 40.8 [12.0] 4.7	56.7 [16.6] 37.3 [10.9] 4.6	55.2 [16.2] 48.1 [14.1] 4.7	54.0 [15.8] 45.6 [13.4] 4.6	52.2 [15.3] 41.7 [12.2] 4.6
	95 [35]	Total BTUH [kW] Sens BTUH [kW] Power	63.1 [18.5] 35.9 [10.5] 5.0	61.8 [18.1] 34.0 [10.0] 4.9	59.7 [17.5] 31.1 [9.1] 4.8	58.0 [17.0] 42.0 [12.3] 4.9	56.8 [16.6] 39.8 [11.7] 4.9	54.9 [16.1] 36.4 [10.7] 4.8	53.4 [15.7] 47.1 [13.8] 4.9	52.2 [15.3] 44.7 [13.1] 4.9	50.5 [14.8] 40.8 [12.0] 4.8
	100 [37.8]	Total BTUH [kW] Sens BTUH [kW] Power	61.1 [17.9] 34.8 [10.2] 5.2	59.9 [17.6] 33.0 [9.7] 5.2	57.9 [17.0] 30.2 [8.9] 5.1	56.1 [16.4] 41.0 [12.0] 5.2	54.9 [16.1] 38.9 [11.4] 5.1	53.1 [15.6] 35.5 [10.4] 5.0	51.4 [15.1] 46.1 [13.5] 5.2	50.3 [14.7] 43.7 [12.8] 5.1	48.6 [14.2] 39.9 [11.7] 5.0
	105 [40.6]	Total BTUH [kW] Sens BTUH [kW] Power	59.1 [17.3] 33.7 [9.9] 5.5	57.8 [16.9] 31.9 [9.3] 5.4	55.9 [16.4] 29.2 [8.6] 5.3	54.0 [15.8] 39.9 [11.7] 5.4	52.9 [15.5] 37.8 [11.1] 5.4	51.1 [15.0] 34.6 [10.1] 5.3	49.3 [14.4] 45.0 [13.2] 5.4	48.3 [14.2] 42.6 [12.5] 5.3	46.7 [13.7] 39.0 [11.4] 5.3
	110 [43.3]	Total BTUH [kW] Sens BTUH [kW] Power	56.9 [16.7] 32.6 [9.6] 5.7	55.7 [16.3] 30.9 [9.1] 5.7	53.8 [15.8] 28.2 [8.3] 5.6	51.8 [15.2] 38.8 [11.4] 5.7	50.8 [14.9] 36.7 [10.8] 5.6	49.1 [14.4] 33.6 [9.8] 5.5	47.2 [13.8] 43.8 [12.8] 5.7	46.2 [13.5] 41.5 [12.2] 5.6	44.6 [13.1] 38.0 [11.1] 5.5
	115 [46.1]	Total BTUH [kW] Sens BTUH [kW] Power	54.6 [16.0] 31.3 [9.2] 6.0	53.5 [15.7] 29.7 [8.7] 5.9	51.7 [15.2] 27.1 [7.9] 5.8	49.6 [14.5] 37.5 [11.0] 6.0	48.5 [14.2] 35.6 [10.4] 5.9	46.9 [13.7] 32.5 [9.5] 5.8	44.9 [13.2] 42.6 [12.5] 5.9	43.9 [12.9] 40.4 [11.8] 5.9	42.5 [12.5] 36.9 [10.8] 5.8
	120 [48.9]	Total BTUH [kW] Sens BTUH [kW] Power	52.2 [15.3] 30.1 [8.8] 6.3	51.1 [15.0] 28.5 [8.4] 6.2	49.4 [14.5] 26.0 [7.6] 6.1	47.2 [13.8] 36.3 [10.6] 6.3	46.2 [13.5] 34.4 [10.1] 6.2	44.6 [13.1] 31.4 [9.2] 6.1	42.5 [12.5] 41.4 [12.1] 6.2	41.6 [12.2] 39.2 [11.5] 6.2	40.2 [11.8] 35.8 [10.5] 6.1
	125 [51.7]	Total BTUH [kW] Sens BTUH [kW] Power	49.7 [14.6] 28.7 [8.4] 6.6	48.7 [14.3] 27.2 [8.0] 6.5	47.0 [13.8] 24.9 [7.3] 6.4	44.7 [13.1] 34.9 [10.2] 6.6	43.7 [12.8] 33.1 [9.7] 6.5	42.3 [12.4] 30.2 [8.9] 6.4	40.0 [11.7] 40.0 [11.7] 6.5	39.1 [11.5] 37.9 [11.1] 6.5	37.8 [11.1] 34.7 [10.2] 6.4

DR —Depression ratio
dbE —Entering air dry bulb
wbE—Entering air wet bulb

Total —Total capacity x 1000 BTUH
Sens —Sensible capacity x 1000 BTUH
Power —KW input

NOTES:①When the entering air dry bulb is other than 80°F [27°C], adjust the sensible capacity from the table by adding [1.10 x CFM x (1 – DR) x (dbE – 80)].

[] Designates Metric Conversions

INDOOR AIRFLOW PERFORMANCE RACBZR – 208/230 VOLTS

Nominal Cooling Capacity Tons [kW]	Motor Speed from Factory		Manufacturer Recommended Cooling Airflow (Min/Max)	Blower Size, Motor HP [W] & # of Speeds	Motor Tap - Usage	External Static Pressure - Inches W.C. [kPa] (Side Discharge-Dry Coil)										
	Cool	Heat				0.1 [0.02]	0.2 [0.05]	0.3 [0.07]	0.4 [0.10]	0.5 [0.12]	0.6 [0.15]	0.7 [0.17]	0.8 [0.20]	0.9 [0.22]	1.0 [0.25]	
2.0 [7.03]	Tap 2	Tap 1	700 CFM / 950 CFM	10X9 Blower 1/2 HP [372] 3 Speed (Constant Torque)	Tap 1 Low	CFM	1038	979	919	849	751	700	647	595	524	457
						RPM	496	571	635	710	785	833	878	948	991	1036
	Watts	89	99	109	120	130	137	143	153	159	166					
2.5 [7.79]	Tap 2	Tap 1	1000 CFM / 1400 CFM	12x9T Blower 1/2 HP [372] 3 Speed (Constant Torque)	Tap 1 Low	CFM	1364	1091	1036	984	896	813	782	727	675	603
						RPM	576	590	650	709	794	856	895	939	1017	1068
	Watts	164	122	131	141	155	165	173	179	193	201					
3.0 [10.55]	Tap 2	Tap 1	1000 CFM / 1400 CFM	12x9T Blower 1/2 HP [372] 3 Speed (Constant Torque)	Tap 1 Low	CFM	1211	1162	1114	1064	1014	866	813	754	699	636
						RPM	546	611	674	736	795	889	932	985	1037	1066
	Watts	124	136	147	159	169	186	193	204	213	219					
3.5 [12.31]	Tap 2	Tap 1	1200 CFM / 1600 CFM	12x9T Blower 3/4 HP [559] 3 Speed (Constant Torque)	Tap 1 Low	CFM	1394	1273	1222	1183	1141	1083	1027	910	884	851
						RPM	586	624	687	736	791	845	910	998	1026	1068
	Watts	174	165	176	188	199	210	224	244	249	259					
3.0 [10.55]	Tap 2	Tap 1	1000 CFM / 1400 CFM	12x9T Blower 1/2 HP [372] 3 Speed (Constant Torque)	Tap 1 Low	CFM	1350	1313	1272	1230	1176	1131	1062	980	947	911
						RPM	622	664	717	771	8228	878	951	1010	1044	1079
	Watts	178	187	200	213	225	236	253	266	275	284					
3.5 [12.31]	Tap 2	Tap 1	1200 CFM / 1600 CFM	12x9T Blower 3/4 HP [559] 3 Speed (Constant Torque)	Tap 1 Low	CFM	1519	1480	1438	1398	1362	1319	1266	1226	1153	1058
						RPM	668	719	763	811	859	908	964	1009	1076	1120
	Watts	240	254	266	280	293	307	321	336	355	358					
3.5 [12.31]	Tap 2	Tap 1	1200 CFM / 1600 CFM	12x9T Blower 3/4 HP [559] 3 Speed (Constant Torque)	Tap 1 Low	CFM	1575	1531	1478	1431	1389	1345	1297	1242	1184	1132
						RPM	604	639	684	726	768	810	854	898	947	988
	Watts	237	248	263	276	289	304	318	332	348	362					
3.5 [12.31]	Tap 2	Tap 1	1200 CFM / 1600 CFM	12x9T Blower 3/4 HP [559] 3 Speed (Constant Torque)	Tap 1 Low	CFM	1760	1713	1667	1619	1584	1550	1507	1465	1426	1379
						RPM	645	683	723	762	799	837	875	917	957	999
	Watts	311	325	341	355	371	386	402	418	434	451					

NOTES: (1) For Constant Torque Motors: Use motor taps 3-5 to achieve rated airflow at AHRI minimum external static pressure.

[] Designates Metric Conversions

INDOOR AIRFLOW PERFORMANCE RACBZR — 208/230 VOLTS (Con't.)

Nominal Cooling Capacity Tons [kW]	Motor Speed from Factory		Manufacturer Recommended Cooling Airflow (Min/Max)	Blower Size, Motor HP [W] & # of Speeds	Motor Tap - Usage	External Static Pressure - Inches W.C. [kPa] (Side Discharge-Dry Coil)										
	Cool	Heat				0.1 [.02]	0.2 [.05]	0.3 [.07]	0.4 [.10]	0.5 [.12]	0.6 [.15]	0.7 [.17]	0.8 [.20]	0.9 [.22]	1.0 [.25]	
4.0 [14.07]	Tap 2	Tap 1	1350 CFM / 1850 CFM	12x9T Blower 3/4 HP [559] 3 Speed (Constant Torque)	Tap 1 Low	CFM	1725	1669	1622	1573	1529	1478	1431	1377	1338	1294
						RPM	591	626	662	708	749	793	841	904	937	967
						Watts	273	281	294	311	326	342	360	383	395	407
5.0 [17.59]	Tap 2	Tap 1	1600 CFM / 2100 CFM	12x9R Blower 1 HP [746] 5 Speed (Constant Torque)	Tap 1 Low	CFM	1826	1789	1745	1696	1651	1615	1556	1519	1468	1412
						RPM	616	646	684	722	764	809	853	895	945	997
						Watts	320	331	349	359	382	401	417	437	457	477
5.0 [17.59]	Tap 2	Tap 1	1600 CFM / 2100 CFM	12x9R Blower 1 HP [746] 5 Speed (Constant Torque)	Tap 2 High	CFM	2153	2125	2073	2051	2005	1974	1937	1898	1865	1839
						RPM	695	718	757	780	818	843	883	919	947	978
						Watts	472	484	504	518	538	550	574	591	607	628
5.0 [17.59]	Tap 2	Tap 1	1600 CFM / 2100 CFM	12x9R Blower 1 HP [746] 5 Speed (Constant Torque)	Tap 2 High	CFM	-	2256	2219	2171	2163	2128	2091	2045	2026	1987
						RPM	-	755	786	822	840	876	907	943	961	999
						Watts	-	581	600	621	632	655	673	695	708	735

NOTES:

(1) For Constant Torque Motors: Use motor taps 3-5 to achieve rated airflow at AHRI minimum external static pressure.

DOWN DISCHARGE PRESSURE DROP (ADD TO EXTERNAL STATIC PRESSURE)							
CFM [L/s]	800 [378]	1000 [472]	1200 [566]	1400 [661]	1600 [755]	1800 [849]	2000 [944]
Pressure Drop—Includes W.C. [kPa]	.02 [.005]	.05 [.012]	.07 [.017]	.1 [.025]	.12 [.030]	.15 [.037]	.17 [.042]

[] Designates Metric Conversions

ELECTRICAL DATA - RACBZR SERIES							
		024AJT	030AJT	036AJT	042AJT	048AJT	060AJT
Unit Information	Unit Operating Voltage Range	187-253	187-253	187-253	187-253	187-253	187-253
	Volts	208/230	208/230	208/230	208/230	208/230	208/230
	Phase	1	1	1	1	1	1
	Hz	60	60	60	60	60	60
	Minimum Circuit Ampacity	20	21	24	28	31	38
	Minimum Overcurrent Protection Device Size	25	30	35	40	45	50
	Maximum Overcurrent Protection Device Size	30	35	40	45	50	60
Compressor Motor	No.	1	1	1	1	1	1
	Volts	208/230	208/230	208/230	208/230	208/230	208/230
	Phase	1	1	1	1	1	1
	RPM	3450	3450	3450	3450	3450	3450
	HP, Compressor 1	2	2 1/2	3	3 1/2	4	4 1/2
	Amps (RLA), Comp. 1	10.8	12.3	14.7	15.9	18.3	27.1
	Amps (LRA), Comp. 1	55	63	75	112.3	108	144
	HP, Compressor 2						
	Amps (RLA), Comp. 2						
Amps (LRA), Comp. 2							
Condenser Motor	No.	1	1	1	1	1	1
	Volts	208/230	208/230	208/230	208/230	208/230	208/230
	Phase	1	1	1	1	1	1
	HP	1/3	1/3	1/3	1/3	1/3	1/3
	Amps (FLA, each)	1.5	1.5	1.5	1.5	1.8	1.8
	Amps (LRA, each)	3	3	3	3	3.3	3.3
Evaporator Fan	No.	1	1	1	1	1	1
	Volts	208/230	208/230	208/230	208/230	208/230	208/230
	Phase	1	1	1	1	1	1
	HP	1/2	1/2	1/2	3/4	3/4	1
	Amps (FLA, each)	4.1	4.1	4.1	6	6	7.6
	Amps (LRA, each)	3					

208/240 VOLT, SINGLE PHASE, 60 Hz, AUXILIARY ELECTRIC HEATER KITS CHARACTERISTICS AND APPLICATION															
Separate Power Supply for Both Unit and Heater Kit															
Friedrich® Model Number	Heater Kit					Air Conditioner				Heater Kit				Air Conditioner	
	RXQJ- Heater Kit Nominal kW	No. of Sequence Steps	Rated Heater kW @ 208/240 V	Heater kW @ 208/240 V	Heater Amp. @ 208/240 V	Unit Min. Ckt. Ampacity @ 208/240 V	Over Current Protective Device Size		Min. Ckt. Ampacity 208/240V	Max. Fuse Size 208/240V	Min. Ckt. Ampacity 208/240V	Over Current Protective Device Size			
							Min./Max. @ 208 V	Min./Max. @ 240 V				Min./Max. @ 208 V	Min./Max. @ 240 V		
RACBZR024AJT	No Heat	—	—	—	—	20/20	25/30	25/30	—	—	20/20	25/30	25/30		
	C05J	1	3.6/4.8	12.28/16.38	17.3/20.0	27/31	30/30	35/35	22/25	25/25	20/20	25/30	25/30		
	C07J	1	5.4/7.2	18.43/24.57	26.0/30.0	38/43	40/40	45/45	33/38	35/40	20/20	25/30	25/30		
	C10J	1	7.2/9.6	24.57/32.76	34.7/40.0	49/56	50/50	60/60	44/50	45/50	20/20	25/30	25/30		
RACBZR030AJT	No Heat	—	—	—	—	21/21	30/35	30/35	—	—	21/21	30/35	30/35		
	C05J	1	3.6/4.8	12.28/16.38	17.3/20.0	27/31	30/35	35/35	22/25	25/25	21/21	30/35	30/35		
	C07J	1	5.4/7.2	18.43/24.57	26.0/30.0	38/43	40/40	45/45	33/38	35/40	21/21	30/35	30/35		
	C10J	1	7.2/9.6	24.57/32.76	34.7/40.0	49/56	50/50	60/60	44/50	45/50	21/21	30/35	30/35		
	C15J	1	10.8/14.4	36.85/49.13	52.0/60.0	71/81	80/80	90/90	65/75	70/80	21/21	30/35	30/35		
RACBZR036AJT	No Heat	—	—	—	—	24/24	35/40	35/40	—	—	24/24	35/40	35/40		
	C05J	1	3.6/4.8	12.28/16.38	17.3/20.0	27/31	35/40	35/40	22/25	25/25	24/24	35/40	35/40		
	C07J	1	5.4/7.2	18.43/24.57	26.0/30.0	38/43	40/40	45/45	33/38	35/40	24/24	35/40	35/40		
	C10J	1	7.2/9.6	24.57/32.76	34.7/40.0	49/56	50/50	60/60	44/50	45/50	24/24	35/40	35/40		
	C15J	1	10.8/14.4	36.85/49.13	52.0/60.0	71/81	80/80	90/90	65/75	70/80	24/24	35/40	35/40		
RACBZR042AJT	No Heat	—	—	—	—	28/28	40/45	40/45	—	—	28/28	40/45	40/45		
	C05J	1	3.6/4.8	12.28/16.38	17.3/20.0	30/33	40/45	40/45	22/25	25/25	28/28	40/45	40/45		
	C07J	1	5.4/7.2	18.43/24.57	26.0/30.0	40/45	40/45	45/45	33/38	35/40	28/28	40/45	40/45		
	C10J	1	7.2/9.6	24.57/32.76	34.7/40.0	51/58	60/60	60/60	44/50	45/50	28/28	40/45	40/45		
	C15J	1	10.8/14.4	36.85/49.13	52.0/60.0	73/83	80/80	90/90	65/75	70/80	28/28	40/45	40/45		
	C20J	1	14.4/19.2	49.13/65.51	69.3/80.0	95/108	100/100	110/110	87/100	90/100	28/28	40/45	40/45		
RACBZR048AJT	No Heat	—	—	—	—	31/31	45/50	45/50	—	—	31/31	45/50	45/50		
	C05J	1	3.6/4.8	12.28/16.38	17.3/20.0	31/33	45/50	45/50	22/25	25/25	31/31	45/50	45/50		
	C07J	1	5.4/7.2	18.43/24.57	26.0/30.0	40/45	45/50	45/50	33/38	35/40	31/31	45/50	45/50		
	C10J	1	7.2/9.6	24.57/32.76	34.7/40.0	51/58	60/60	60/60	44/50	45/50	31/31	45/50	45/50		
	C15J	1	10.8/14.4	36.85/49.13	52.0/60.0	73/83	80/80	90/90	65/75	70/80	31/31	45/50	45/50		
	C20J	1	14.4/19.2	49.13/65.51	69.3/80.0	95/108	100/100	110/110	87/100	90/100	31/31	45/50	45/50		
RACBZR060AJT	No Heat	—	—	—	—	38/38	50/60	50/60	—	—	38/38	50/60	50/60		
	C05J	1	3.6/4.8	12.28/16.38	17.3/20.0	38/38	50/60	50/60	22/25	25/25	38/38	50/60	50/60		
	C07J	1	5.4/7.2	18.43/24.57	26.0/30.0	42/47	50/60	50/60	33/38	35/40	38/38	50/60	50/60		
	C10J	1	7.2/9.6	24.57/32.76	34.7/40.0	53/60	60/60	60/60	44/50	45/50	38/38	50/60	50/60		
	C15J	1	10.8/14.4	36.85/49.13	52.0/60.0	75/85	80/80	90/90	65/75	70/80	38/38	50/60	50/60		
C20J	1	14.4/19.2	49.13/65.51	69.3/80.0	97/110	100/100	110/110	87/100	90/100	38/38	50/60	50/60			

DIMENSIONS

Model	Height "A"
024, 030, 036, 042	29 1/8"
048,060	37 1/8"

FRONT VIEW

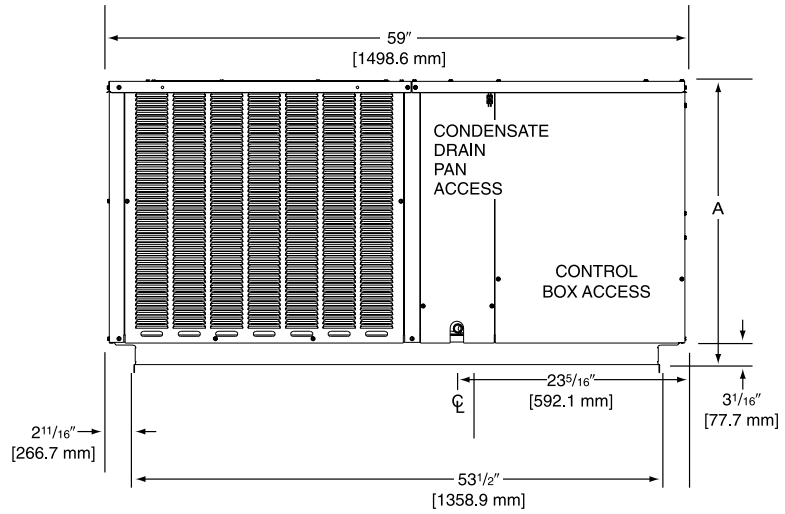

REAR VIEW

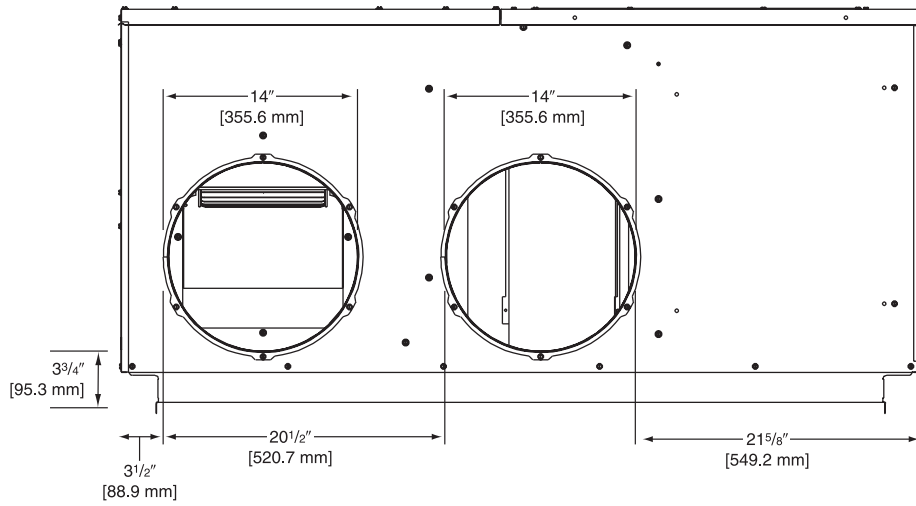

ELECTRICAL CONNECTIONS

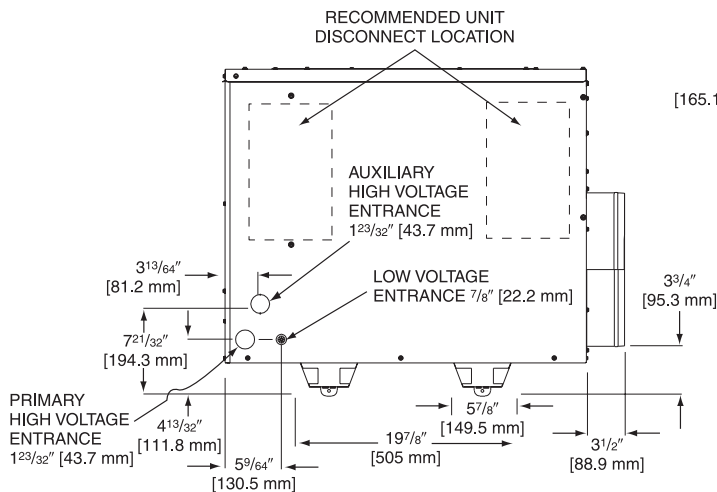

BOTTOM VIEW

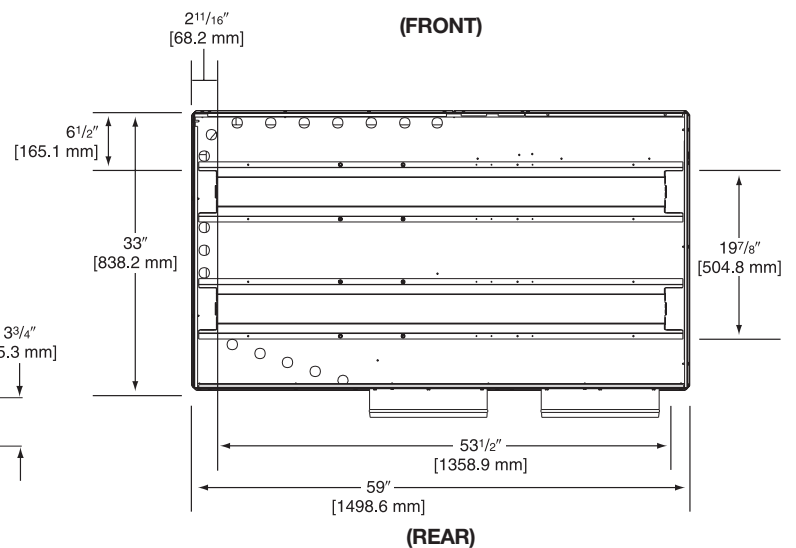

[] Designates Metric Conversions

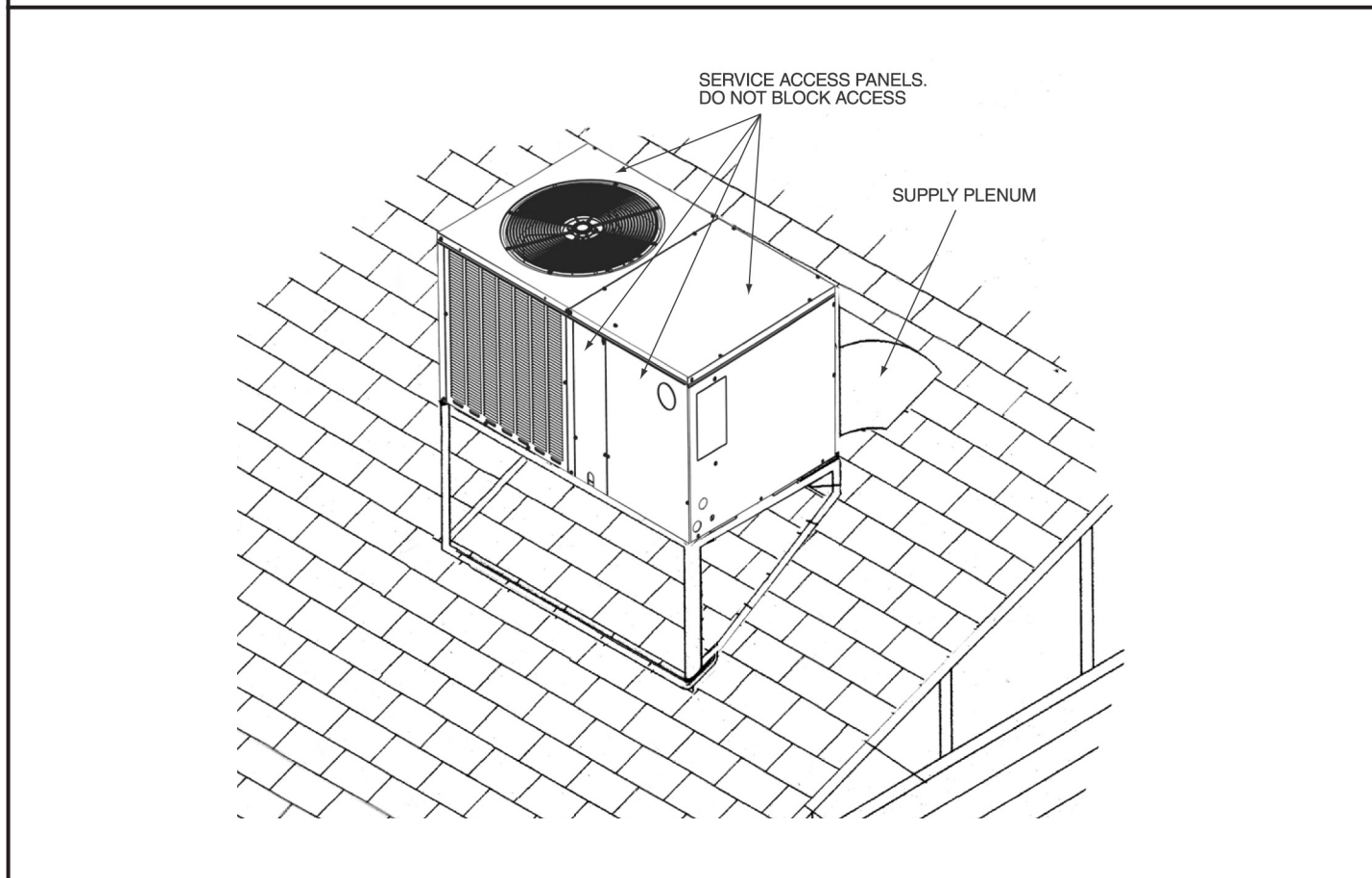
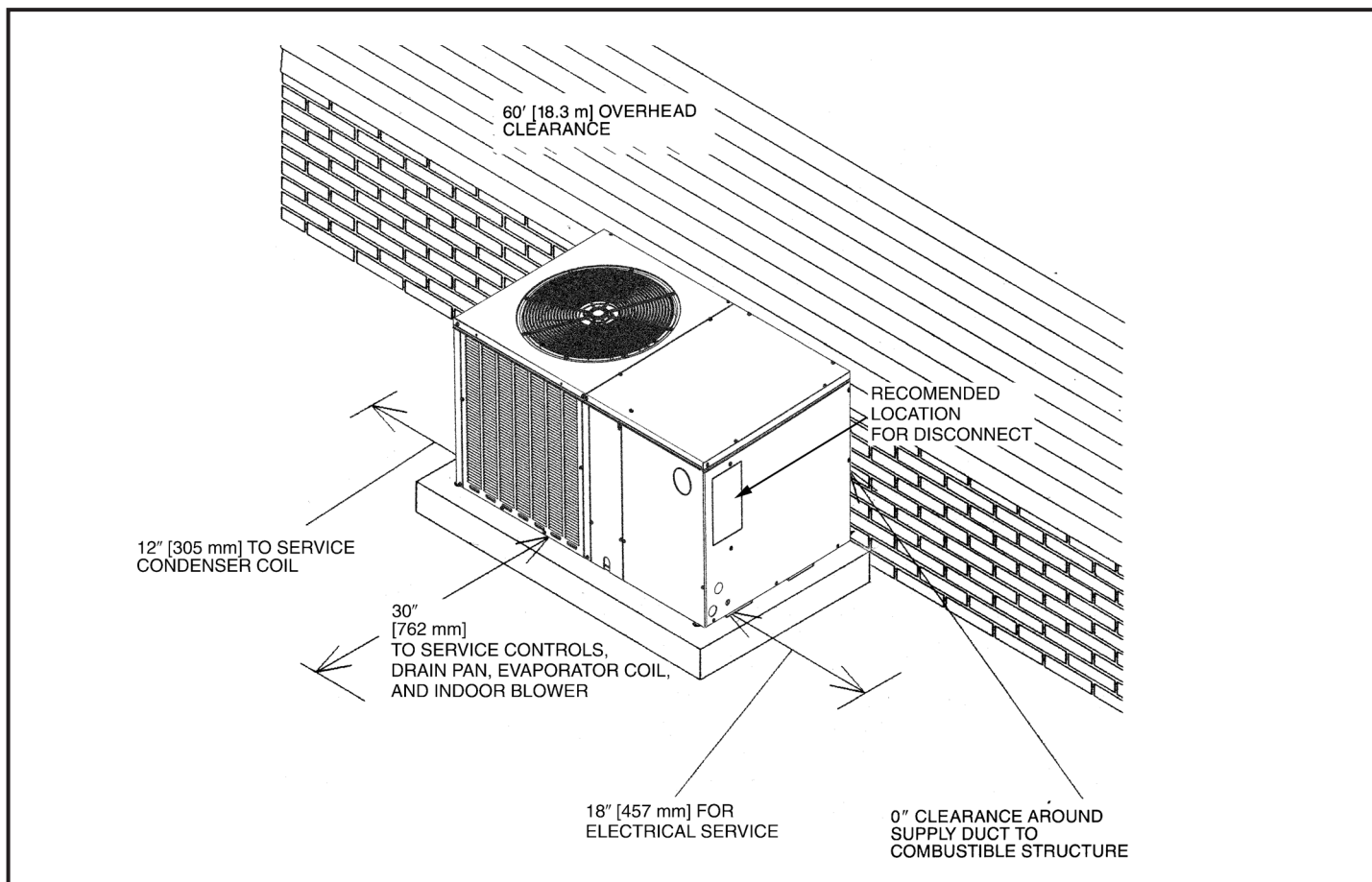

[] Designates Metric Conversions



FRIEDRICH

1 8 8 3

BEFORE PURCHASING THIS APPLIANCE, READ IMPORTANT ENERGY COST AND EFFICIENCY INFORMATION AVAILABLE FROM YOUR RETAILER.

GENERAL TERMS OF LIMITED WARRANTY*

Friedrich® will furnish a replacement for any part of this product which fails in normal use and service within the applicable periods stated, in accordance with the terms of the limited warranty.

***For complete details of the Limited and Conditional Warranties, including applicable terms and conditions, contact your local contractor or the Manufacturer for a copy of the product warranty certificate.**

Conditional Parts (Registration Required)

(1 Phase, Residential Applications) Ten (10) Years

Compressor

(1 Phase, Residential Applications) Ten (10) Years

(1 & 3 Phase, Commercial Applications) Five (5) Years

Parts

(3 Phase, Commercial Applications).....One (1) Year

Before proceeding with installation, refer to installation instructions packaged with each model, as well as complying with all Federal, State, Provincial, and Local codes, regulations, and practices.

© 2023 Rheem Manufacturing Company. Friedrich trademarks are owned by Friedrich Air Conditioning LLC.
Rheem and other trademarks are owned by Rheem Manufacturing Company.

In keeping with its policy of continuous progress and product improvement, Friedrich reserves the right to make changes without notice.

5600 Old Greenwood Road
Fort Smith, Arkansas 72908 • www.friedrich.com

125 Edgeware Road, Unit 1
Brampton, Ontario • L6Y 0P5