



**FRIEDRICH**

1 8 8 3

**Friedrich® Commercial Renaissance™ Line  
Packaged Air Conditioner**



**RACDZT Commercial *F-Series***

Nominal Sizes 7.5, 8.5, 10 & 12.5 Tons  
Standard VFD and optional HumidiDry™ Technology  
ASHRAE 90.1-2019 Compliant Models



## TABLE OF CONTENTS

Unit Features and Benefits.....	3-11
Model Number Identification .....	12
Options .....	13
Selection Procedure .....	14
General Data .....	15
General Data Notes .....	16
Gross Systems Performance Data.....	17-24
Airflow Performance Data .....	25-40
Electrical Data .....	41-46
Electric Heater Kits.....	47-52
Dimensional Data .....	53-55
Field Installed Accessories.....	56-77
Guide Specifications .....	78-85
Limited Warranty .....	86



	Single-Stage Cooling	Two-Stage Cooling	2023 DOE Efficiency Standards Compliant	VFD Technology	HumidiDry™
Commercial <i>F-Series</i> (RACDZT)		X	X	X	X (Optional)

## RACD STANDARD FEATURES INCLUDE:

- Factory charged with R-410A HFC refrigerant
- Wired and run tested
- Scroll compressors with internal line break overload and high pressure protection
- Unit has a two-stage compressor
- Convertible airflow – vertical down flow or horizontal side flow
- Forkable base rails for easy handling and lifting
- Cooling operation up to 125°F ambient
- MicroChannel evaporator and condenser coil
- PlusOne® ServiceSmart package includes:  
 Qwik-Change Flex-Fit Rack™  
 Qwik-Slide Blower Assembly™  
 Qwik-Clean Drain Pan™
- Overflow condensate sensor
- PlusOne® Diagnostics with Dual 7-Segment LED Display to meet code compliance
- One-piece top cover and base pan with drawn supply and return opening
- Two-piece control door
- ¼ turn fasteners on filter access door
- Color-coded and labeled wiring
- External lockable gauge ports
- TXV refrigerant metering system
- Solid-core liquid line filter drier
- High pressure and low pressure/loss of charge protection with built in Smart Logic
- Insulation encapsulated throughout entire unit
- High performance belt drive motor with variable pitch pulleys and quick adjust belt system
- Variable Frequency Drive (VFD) blower is standard
- Industry standard footprint and matching connections
- MERV 8 & MERV 13 filters are available as an accessory

## FACTORY INSTALLED OPTIONS:

- Louvered panels
- Hinged access doors
- PlusOne® HumidiDry™ Dehumidification System
- Low ambient/freeze stat
- Non-powered convenience outlet
- Economizer (Title 24 and ASHRAE 90.1 2013 Compliant)

- Supply and return smoke detector
- Return smoke detector
- ElectroFin® E-Coat for Microchannel Condenser Coil
- ClearControl™ Direct Digital Control (DDC)
- Comfort Alert/Phase monitor
- Vertical economizer

## FIELD INSTALLED ACCESSORY EQUIPMENT:

Accessory	Model Number	Factory Installation Available?
Economizer w/Single Enthalpy (Downflow)	RXRD-01MDDAM3	Yes
Economizer w/Single Enthalpy (Horizontal)	RXRD-01MDHAM3	No
Economizer-w/Single Enthalpy (Downflow) DDC	RXRD-01MDDBM3	Yes
Economizer w/Single Enthalpy (Horizontal) DDC	RXRD-01MDHBM3	No
Dual Enthalpy Kit	RXXR-BV01	No
Dual Enthalpy Kit DDC	RXXR-BV02	No
Carbon Dioxide Sensor (Wall Mount)	RXXR-AR02	No
Power Exhaust	RXXR-CDF01C	No
Power Exhaust	RXXR-CDF01D	No
Manual Fresh Air Damper	RXXR-ADA1	No
Motorized Fresh Air Damper	RXXR-ADB1	No
Motorized Fresh Air Damper (DDC)	RXXR-ADC1	No
Roofcurb, 14"	RXKG-DDD14	No
Roofcurb, 24"	RXKG-DDD24	No
Roofcurb Adapter	RXXR-DDCAE	No
Roofcurb, 14" Welded	RXKG-SD14	No
Roofcurb, 24" Welded	RXKG-SD24	No
Concentric Diffuser 7.5/8.5 Ton Flush	RXXR-AEF2000	No
Concentric Diffuser 10.0 Ton Flush	RXXR-AEF3415	No
Concentric Diffuser 12.5 Ton Flush	RXXR-AEF3618	No
Concentric Diffuser 7.5/8.5 Ton Drop	RXXR-AED2000	No
Concentric Diffuser 10.0 Ton Drop	RXXR-AED3415	No
Concentric Diffuser 12.5 Ton Drop	RXXR-AED3618	No
Concentric Adapter 7.5/8.5 Ton Drop	RXXR-DD01	No
Concentric Adapter 10 Ton Drop	RXXR-DD02	No
Concentric Adapter 12.5 Ton Drop	RXXR-DD03	No
Outdoor Coil Louver Kit - ACD/090/102/120	RXXR-ADD04A	Yes
Outdoor Coil Louver Kit - ACD150	RXXR-ADD04B	Yes
Unwired Convenience Outlet	RXXR-BN01	Yes
Unfused Service Disconnect	RXXR-BP01	Yes
Comfort Alert (1 Per Compressor)	RXXR-AZ01 DDC	Yes
Comfort Alert (1 Per Compressor)	RXXR-AZ02	Yes
BACnet Communication Card	RXXR-AY01	No
LonWorks Communication Card	RXXR-AY02	No
Room Humidity Sensor	RHC-ZNS4	No
Room Temperature and Relative Humidity Sensor	RHC-ZNS5	No
Low-Ambient Control Kit	RXXR-A04	Yes

Accessory	Model Number	Factory Installation Available?
Freeze Stat Kit	RXXR-AM01	Yes
Variable Frequency Drive Kit* *See model number break down below	RXXR-AC02	No
	RXXR-AC03	No
	RXXR-AC05	No
	RXXR-AD02	No
	RXXR-AD03	No
	RXXR-AD05	No
	RXXR-CC02	No
	RXXR-CC03	No
	RXXR-CC05	No
	RXXR-CD02	No
	RXXR-CD03	No
	RXXR-CD05	No
	Electric Heater Kits	RXJJ-DD10CP
RXJJ-DD15CP		Yes
RXJJ-DD20CP		Yes
RXJJ-DD30CP		Yes
RXJJ-DD40CP		Yes
RXJJ-DD10DNV		Yes
RXJJ-DD15DNV		Yes
RXJJ-DD20DNV		Yes
RXJJ-DD30DNV		Yes
RXJJ-DD40DNV		Yes
Single Point Wiring Kit*	RXJX-AC0605	No
	RXJX-AC0805	No
	RXJX-AD0605	No
	RXJX-AC0909	No
	RXJX-AD0609	No
MERV 8 Filter 7.5-10 Ton	RXXR-M08A22020	No
MERV 8 Filter 12.5 Ton	RXXR-M08A22520	No
MERV 13 Filter 7.5-10 Ton	RXXR-M13A22020	No
MERV 13 Filter 12.5 Ton	RXXR-M13A22520	No
Flue Diverter	RXXR-DFG04	No
Smoke Detector Kit - Return	RXXR-BS03	No
Smoke Detector Kit - Return/Supply	RXXR-BS04	No
UV-C Light Kit (208/230V)	RXXR-UVC34D	No
UV-C Transformer Kit (460/575V)	RXXR-UVCTD	No

\*See single point wiring kit model nomenclature on page 57.

\*Variable Frequency Drive Kit model nomenclature on page 57.



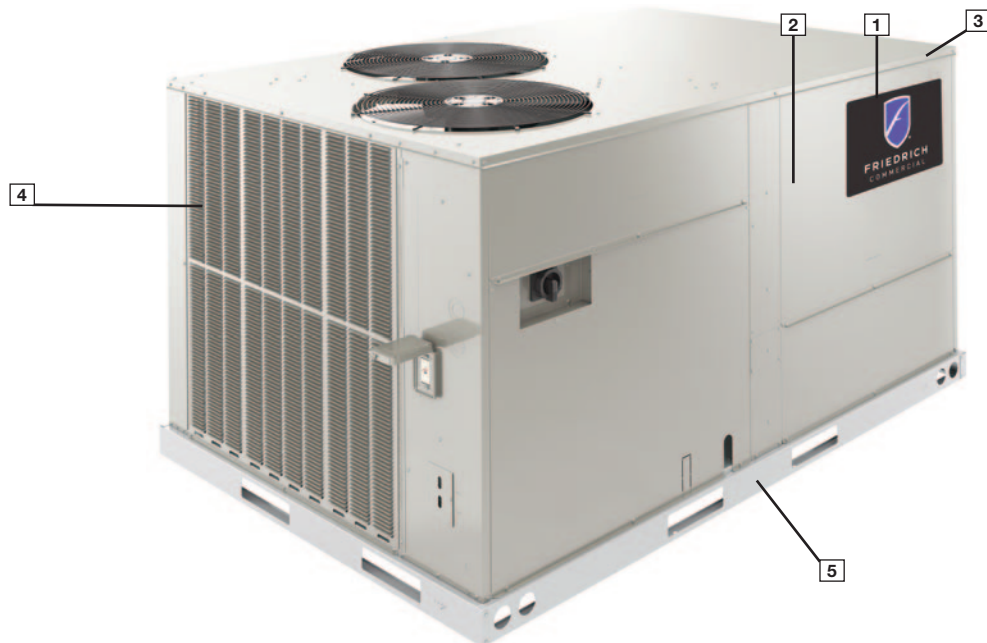

### Cabinet and Foundation

Outwardly, the large *Friedrich® Commercial Series* label (1) identifies the brand to the customer. The sheet-metal cabinet (2) uses 18-gauge material for structural components with an underlying coat of G90. To ensure the leak-proof integrity of these units, the design utilizes a one-piece top with a 1/8" drip lip (3) as well as gasket-protected panels and screws. The Friedrich hail guard (optional) (4) sets the standard for coil protection in the industry. Electro deposition, baked-on enamel that is tested to withstand a rigorous 1000-hour salt spray test, per ASTM B117.

Anything built to last must start with the right foundation. Following that model, the foundation is comprised of 14-gauge, commercial-grade, full perimeter base rails (5) that integrate fork slots and rigging holes to save set-up time on the job site.

### Easy Installation

The Renaissance line features a new footprint that simplifies the replacement process by eliminating the need for a new curb adapter and being able to match inlet, outlet and electrical connections of the most common/industry-standard configurations.

### Base Pan

The base pan is stamped to form a 7/8" flange around the supply and return cover, which eliminates the worry of water entering the conditioned space (6). All insulation is secured with both adhesive and mechanical fasteners, and all edges are hidden.

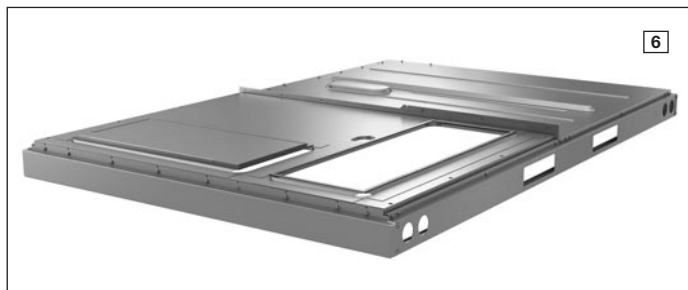

### Drain Pan

The Qwik-Clean Drain Pan™ (7) is made from a composite material that resists the growth of harmful bacteria. With both side and center drain options, the drain pan slides out completely for easy cleaning. It also features a standard overflow switch.

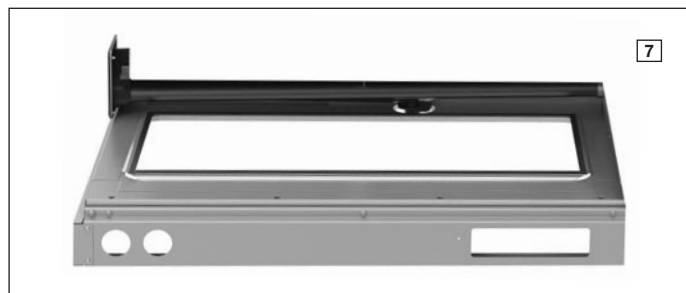

### Test Standards

During development, each unit was tested to U.L. 1995, AHRI 340-360 as well as other Friedrich-required reliability tests. Friedrich adheres to stringent ISO 9002 quality procedures, and each unit bears the U.L. and AHRI certification labels located on the unit nameplate. Contractors can be assured that when a Friedrich package unit arrives at the job, it is ready to go with a factory charge and quality checks. Each unit also proudly displays the "Made in the USA" designation.

### Easy Access

All major compartments are easily accessible from the front of the unit: the electrical compartment, blower compartment, heating section, and outdoor section. Each compartment has mechanical fasteners. Panels are permanently embossed with the compartment name (e.g. control/filter access, blower access, and electric heat access). The filter compartment is accessed through a large, mechanically fastened panel. Information is readily available on the outside of the panel, with a nameplate that contains the model and serial numbers, electrical data, and other important unit information. Hinged access is available as an option for the electrical, blower, and filter compartments.

## Charging Charts, Wiring Diagrams, & Labels

The unit charging chart is located on the outside of the compressor access panel. Electrical wiring diagrams are found on the control box cover, which allows contractors to move them to more readable locations. The model and serial numbers are located on the right of the control box. Having this information on the inside means easier model identification for the life of the product. The production line quality test assurance label is also placed in this location (8).

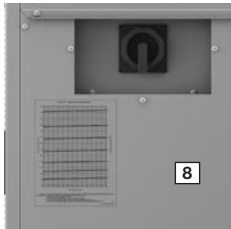

## Filter Rack

Located within the filter compartment, the Qwik-Change Flex-Fit Rack™ (9) allows easy changeover between 2" and 4" standard size and readily available filters.



## Blower Assembly

Removing three screws provides full access to the blower compartment. Inside, the Qwik-Slide Blower Assembly™ (10) is incredibly easy to access and remove. This makes servicing internal components such as blower motor, TXV, and microchannel coil much easier. The entire assembly slides out by removing the 3/8" screws from the blower retention bracket. The adjustable motor pulley (11) can easily be adjusted by loosening the bolts on either side of the motor mount. Removing the bolts allows for easy removal of the blower pulley by pushing the blower assembly up to loosen the belt. Once the pulley is removed, the motor sheave can be adjusted to the desired number of turns, ranging from 0 to 6 turns open.

Where the demands for the job require high static, Friedrich® offers drives that deliver nominal airflow up to 2" of static. By referring to the airflow performance tables listed in the installation instructions, proper static pressure and CFM requirements can be dialed in. The scroll housing (12) and blower scroll provide quiet and efficient airflow. The blower sheave is secured by an "H" bushing that firmly secures the pulley to the blower shaft, resulting in years of trouble-free operation. The "H" bushing allows for easy removal of the blower pulley from the shaft. This is an improvement from a set screw, which can score the shaft and create burrs that make blower-pulley removal difficult.

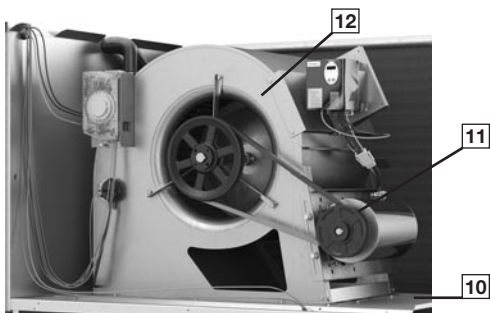

## High and Low Pressure Switches & Freeze Stat

High pressure (13) and low pressure (14) switches are standard. They are located in the outdoor section along with the low-ambient control (15). The optional Freeze Stat (16) (standard on models with ClearControl), is clipped onto the suction line in the blower compartment. The low ambient control allows the compressor to operate down to 0 degrees ambient temperature by cycling the outdoor fans on high pressure. The high-pressure switch shuts off the compressors if pressures exceeding 610 PSIG are detected. The low-pressure switch shuts off the compressors if low pressure is detected due to loss of charge. Built-in Smart Logic reduces nuisance calls by only shutting off compressors after the third detection. The freeze stat protects the compressor if the evaporator coil gets too cold (below freezing) due to low airflow.

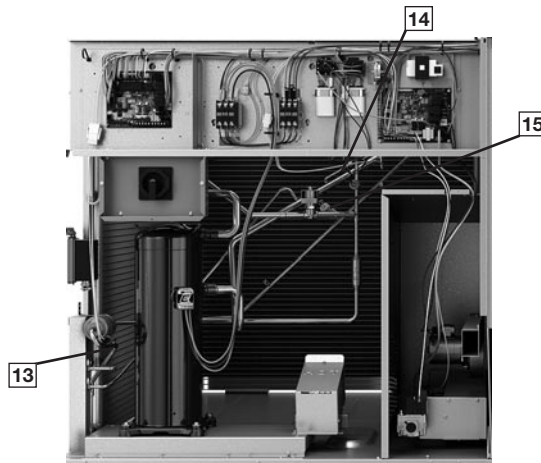

## MicroChannel Evaporator & TXV

The Microchannel Evaporator (17) is accessible through the blower compartment, and through the filter rack, to simplify cleaning. The evaporator uses microchannel technology for maximum heat transfer, light weight, fewer manually brazed connections and reduced refrigerant charge. The TXV metering device maintains superheat over a wide range of varying temperatures optimizing unit performance for all conditions.

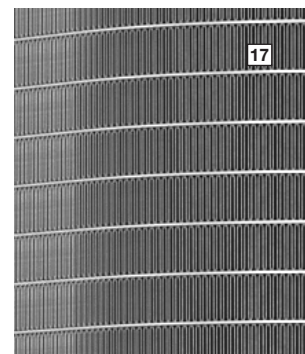

## Control Box

Inside the control box (18), each electrical component is clearly labeled; that label matches the component to the wire diagram for ease of trouble shooting. All wiring is numbered on each end of the termination and is color-coded to match the wiring diagram. The control transformer has a low voltage circuit breaker that trips if an electrical short occurs. There is a blower contactor and compressor contactor for each compressor.

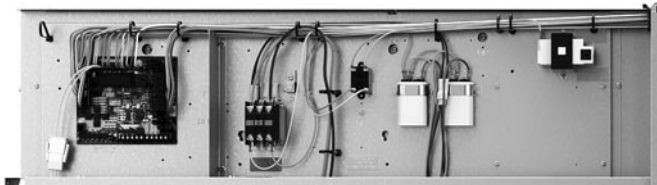

## ClearControl™

The optional ClearControl™ system consisting of a rooftop unit controller, temperature sensors, and pressure sensors, allows real-time monitoring and communication between rooftop units. The Rooftop Unit Controller (RTU-C) that is factory mounted and wired into the control panel. The RTU-C is a solid-state, micro-processor-based control board that provides flexible control and extensive diagnostics for all unit functions. The RTU-C, using proportional/integral control algorithms, performs specific unit functions that govern unit operation in response to zone conditions, system temperatures, system pressures, ambient conditions, and electrical inputs. The RTU-C features a 16 x 2 character LCD display and a five-button keypad for local configuration and direct diagnosis of the system (20). Features include a clogged filter switch (CFS), fan proving switch (FPS), return air temperature sensor (RAT), discharge air temperature sensor (DAT), and outdoor air temperature sensor (OAT). Freeze sensors (FS) are used in place of freeze stats to allow measurement of refrigerant suction line temperatures.



The RACD with the RTU-C is specifically designed to be applied in four distinct applications:

- 1. BACnet Communication** — The RACD is compatible with a third party building management system that supports the BACnet Application Specific Controller device profile, with the use of a field installed BACnet Communication Module. The BACnet Communication Module plugs onto the unit RTU-C controller and allows communication between the RTU-C and the BACnet MSTP network. A zone sensor, a BACnet network zone sensor, a BACnet thermostat, or DDC controller may be used to send the zone temperature or thermostat demands to the RTU-C. The BACnet Communication Module is compatible with MSTP EIA-485 daisy chain networks communicating at 38.4 bps. It is compatible with twisted pair, shielded cables.
- 2. LonWorks Communication** — The RACD is compatible with a third party building management system that supports the LonMark Space Comfort Controller (SCC) functional profile or LonMark Discharge Air Controller (DAC) functional profile. This is accomplished with a field installed LonMark communication module. The LonMark Communication Module plugs onto the RTU-C controller and allows communication between the RTU-C and a LonWorks network. A zone sensor, a LonTalk network zone sensor, or a LonTalk thermostat or DDC controller may be used to send the zone temperature or thermostat demands to the RTU-C. The LonMark Communication Module utilizes an FTT-10A free topology transceiver communicating at 78.8 kbps. It is compatible with Echelon qualified, twisted pair cable, Belden 8471, or NEMA Level 4 cables. The module can communicate up to 1640 feet with no repeater. The LonWorks limit of 64 nodes per segment applies to this device.
- 3. 24V Thermostat Compatibility** — The RACD is compatible with a programmable 24 volt thermostat. Connections are made via conventional thermostat screw terminals. Extensive unit status and diagnostics are displayed on the LCD screen of the RTU-C.
- 4. Zone Sensor Compatibility** — The RACD is compatible with a zone sensor and a mechanical or solid state time clock connected to the RTU-C. Extensive unit status and diagnostics are displayed on the LCD screen of the RTU-C.

## ComfortAlert®

A factory or field installed Comfort Alert® (21) module is available for power phase-monitoring protection and additional compressor diagnostics. The alarms can be displayed on the RTU-C display, through the (BAS) network, or connected to the “L-Terminal” of a thermostat for notification.

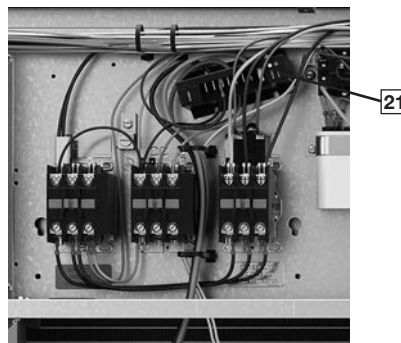



**RACD Series****Variable Frequency Drive**

The supply fan Variable Frequency Drive (VFD) (22) optimizes energy usage year round by providing a lower speed for first stage cooling operation, improving IEER's over the conventional constant fan system. Operating in the constant fan mode at the reduced speed can use as little as 1/5 of the energy of a conventional constant fan system. Also, by operating at a lower speed on first stage cooling, up to 126% more moisture is removed, improving comfort during low load operation. VFD comes standard. The VFD supply fan factory option meets California Title 24 and ASHRAE 90.1-2016 requirements for multi blower speed control. VFD also ramps up to the desired speed, reducing stress on the supply fan components and noise from a sudden inrush of air. Because the airflow is cut in half during first stage cooling and constant fan operation, noise is much less during these modes of operation.

**External Lockable Gauge Ports**

To the right left of the compressor compartment are the externally mounted lockable gauge ports. They are permanently identified by embossed lettering that identifies the compressor circuit, high pressure connection, (25) and low pressure connection (26). Because the gauge ports are mounted externally, an accurate diagnostic of system operation can be performed without removing access panels. Brass caps on the Schrader fitting ensure the gauge parts are leak proof.

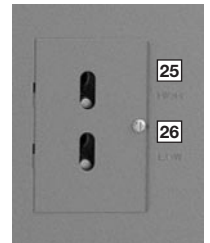
**Convenience Outlet, Disconnect, & Circuit Breaker**

For added convenience in the field, factory-installed options of powered and non-powered convenience outlet (23), disconnect (24) and circuit breakers are available. Low and high voltage can enter from the side or through the base. Low-voltage connections are made through the low-voltage terminal strip. For ease of access, the U.L.-required low voltage barrier can be temporarily removed for low-voltage termination and then reinstalled. The high-voltage connection is terminated at the number 1 compressor contactor. The suggested mounting for the field-installed disconnect or circuit breaker is on the exterior side of the electrical control box.

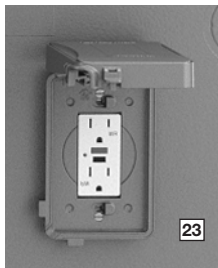

## Compressor

The compressor compartment houses the heart-beat of the unit. The scroll compressor (27) is known for its long life and for reliable, quiet, and efficient operation. The suction and discharge lines are designed with shock loops (28) to absorb the strain and stress that the starting torque, steady state operation, and shut-down cycle impose on the refrigerant tubing. Units have two stages of efficient cooling operation in which the first stage is approximately 50% of second stage. Each unit comes standard with a filter dryer.



## Condenser Fans

The condenser fan motors (29) can easily be accessed and maintained through the top of the unit. A down-mount fan provides corrosion protection and easy removal. The polarized plug connection allows the motor to be changed quickly and eliminates the need to snake wires through the unit.



## MicroChannel Condenser Technology

The outdoor coil uses the latest microchannel technology (30) for the most effective method of heat transfer. The outdoor coil is protected by optional louvered panels, which allow unobstructed airflow while protecting the unit from both the environment and vandalism.

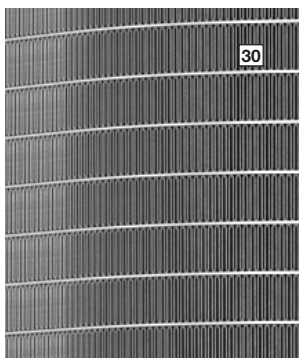

## Coil Coating

Every unit offers the option of factory-applied ElectroFin® E-Coat condenser coating (31) that delivers superior corrosion resistance for outdoor coils to operate in the harshest of environments.



## Economizer and Dampers

Each unit is designed for both down flow or horizontal applications (32) for job configuration flexibility. The return air compartment can also contain an economizer. Each unit is pre-wired for the economizer to allow quick, plug-in installation. Available as a factory-installed option, the economizer provides free cooling when outdoor conditions are suitable and also provides fresh air to meet local requirements. It comes standard with single enthalpy controls, which can be upgraded to dual enthalpy easily in the field. The direct drive actuator combined with gear drive dampers has eliminated the need for linkage adjustment in the field. The economizer control has a minimum position set point, an outdoor-air set point, a mixed-air set point, and a CO<sub>2</sub> set point. Barometric relief is standard on all economizers.

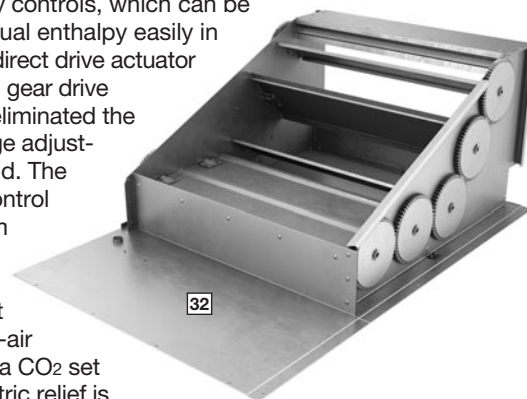

Power Exhaust is easily field-installed. The power exhaust is housed in the barometric relief opening and is easily slipped in with a plugin assembly. The wire harness to the economizer also has accommodations for a smoke detector.

The damper minimum position, actual damper position, power exhaust on/off set point, mixed air temperature limit set point, and Demand Controlled Ventilation (DCV) set point can be read and adjusted at the unit controller display or remotely through a network connection. The Space CO<sub>2</sub> level, mixed air temperature, and Economizer Status (free cooling available, single or dual enthalpy) can be read at the unit controller display or remotely through a network connection. Economizer faults will trigger a network alarm and can be read at the unit controller display or remotely through a network connection.

**RACD Series**

**Roofcurb**

The Friedrich® roofcurb (33) is made for tool-less assembly at the jobsite by engaging tabs in slots of adjacent curb sides, which makes the assembly process quick and easy.



## HUMIDIDRY™ SYSTEM FEATURES

HumidiDry™ is Friedrich®'s exclusive dehumidification package unit solution. It delivers maximum humidity control without compromising desired temperature set point for a high degree of comfort. HumidiDry maintains humidity levels at a desired set point when there's little or no demand for air conditioning. The HumidiDry rooftop unit is controlled by a thermostat and humidistat. The thermostat takes priority on single-stage system. When the thermostat is activated by temperatures that exceed its set point, HumidiDry operates like a standard rooftop unit. It can operate on first stage cooling when demand is low or at full capacity when air conditioning load is high. Unlike other rooftop or reheat units, HumidiDry is uniquely designed so the VFD will operate at a low speed, increasing moisture removal during first-stage cooling operation. This provides initial defense for controlling humidity. When temperature is desirable but humidity exceeds the humidistat set point, the HumidiDry rooftop unit initiates a dehumidification cycle using a combination of hot gas and sub-cooled liquid reheat and the VFD operates at low speed. During this cycle, the HumidiDry rooftop unit delivers dry, neutral air. On a two-stage system, it is possible for both a thermostat and humidistat to register readings above set point. Under this condition, the system runs in the high stage dehumidification cycle, and the VFD operates on high speed. This provides dry conditioned air.

Figure 1 shows the refrigerant path during the normal cooling mode. The liquid refrigerant leaves the TXV with the sudden pressure drop causing the liquid to expand to a vapor and absorbing the heat from the supply air going through the evaporator coil. The refrigerant vapor then travels to the compressor where it is elevated to a higher pressure and temperature. The superheated refrigerant vapor next carries the heat to the outside coil where the heat is then rejected and the refrigerant condenses into a subcooled liquid where the process repeats itself.

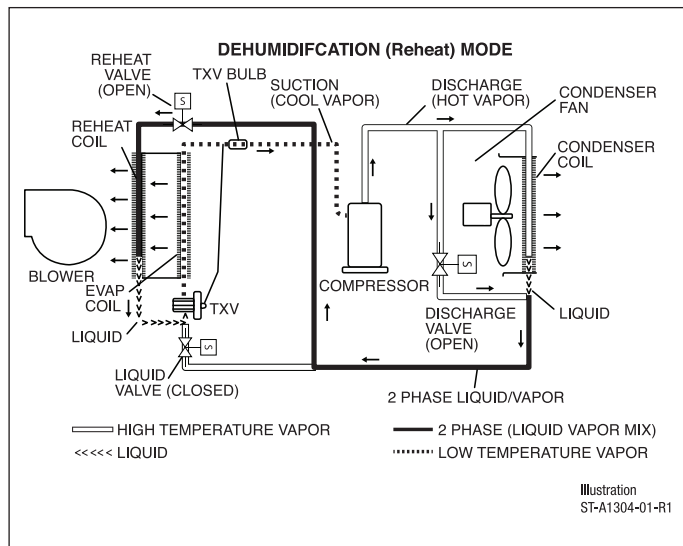
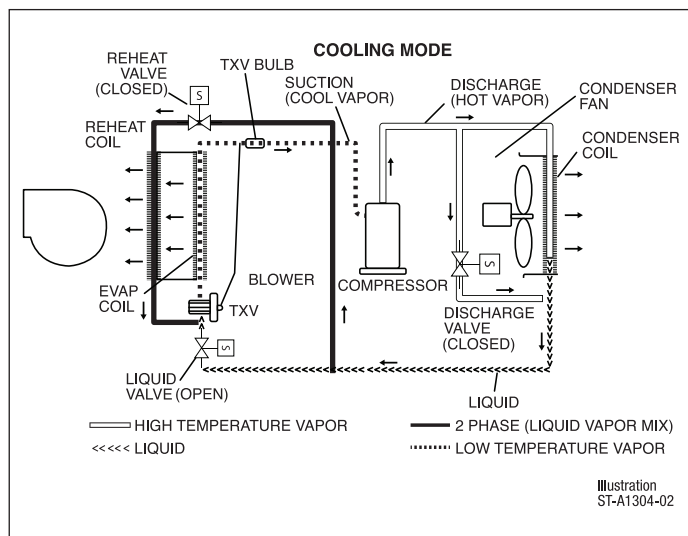

Figure 2 shows the refrigerant path during the reheat mode. When the reheat cycle is energized by the RTU-C, the reheat solenoid valve, upstream of the reheat coil opens. The liquid solenoid valve ahead of the TXV, closes. The discharge solenoid valve, in the compressor discharge line, opens. The liquid refrigerant leaves the TXV with the sudden pressure drop causing the liquid to expand to a vapor and absorbing the heat from the supply air going through the evaporator coil. The refrigerant vapor then travels to the compressor where it is elevated to a higher pressure and temperature. The refrigerant next carries the heat to a parallel path between the outside condenser coil and a bypass circuit. Some of the heat is rejected outdoors. The ratio of heat rejected outdoors versus indoors is controlled by an outdoor fan motor controller (OFMC) that monitors the two-phase temperature and varies the fan speed. This 2-phase refrigerant vapor is then sent to the reheat coil. As the refrigerant travels through the reheat coil it condenses into a subcooled liquid where the process repeats itself.



**R   AC   D   ZT   090   A   C   F   15   2   A   A   \*\*\***  
**1   23   4   56   789   10   11   12   13 14   15   16   17   18 19 20**

---

**1—Brand**

R = Friedrich®

**2, 3—Unit Type**

AC = Packaged AC

**4—Cabinet Type**

D = Medium Commercial

**5, 6—Series**

ZT = 2 Stage Cooling

**7, 8, 9—Capacity**

090 = 7.5 ton

102 = 8.5 ton

120 = 10 ton

150 = 12.5 ton

**10—Major series**

A

**11—Voltage**

C = 3 phase 208-230/60

D = 3 phase 460/60

Y = 3 phase 575/60

**12—Drive**

F = Belt Drive – VFD Low

G = Belt Drive – VFD Medium

H = Belt Drive – VFD High

**13, 14—Heat Capacity**

00 = No Heat

10 = 10kw

15 = 15kw

20 = 20kw

30 = 30kw

40 = 40kw

**15—Number of stages**

0 = No stages

1 = 1 stage

2 = 2 stage

**16—Control**

A = Non communicating

B = Comfort Alert/Phase Monitor

C = Clear Control (DDC)

D = Clear Control (DDC) &

Comfort Alert

**17—Minor series**

A

**18, 19, 20—Option Code**

See next page

## FACTORY INSTALLED OPTION CODES FOR RACD (7.5 TO 12.5 TON)

18					19					20			
LV = Louver protection					LF = Low Ambient / Freeze Stat					EC = Economizer			
RH = Reheat (HumidiDry™) <sup>1</sup> , only available with VFD					NP = Non-powered Convenience Outlet					SS = Supply Smoke			
HA = Hinged Access										RS = Return Smoke			
CC <sup>2</sup> = Coil Coating													
Option code character highlighted below					Option code character highlighted below					Option code character highlighted below			
<b>A</b>	None				<b>A</b>	None				<b>0</b>	None		
<b>B</b>	LV				<b>B</b>	LF				<b>1</b>	EC		
<b>C</b>	HA				<b>C</b>	NP				<b>2</b>	RS		
<b>D</b>	LV	HA			<b>D</b>	LF	NP			<b>3</b>	EC	RS	
<b>E</b>	LV	CC								<b>4</b>	SS	RS	
<b>F</b>	LV	HA	CC							<b>5</b>	EC	SS	RS
<b>N</b>	RH												
<b>P</b>	LV	RH											
<b>Q</b>	RH	HA											
<b>R</b>	LV	RH	CC										
<b>S</b>	LV	RH	HA										
<b>T</b>	LV	RH	HA	CC									

<sup>1</sup>Reheat (HumidiDry™) only available on units with F, G or H drives (VFD) and “C” or “D” control. Low ambient freeze-stat included on all reheat models; low ambient option is not selectable for this unit.

<sup>2</sup>CC-requires LV (louver protection)

### Instructions for Factory Installed Option(s) Selection

Note: Three characters following the model number will be utilized to designate a factory-installed option or combination of options. If no factory option(s) is required, “AAO” follows the model number.

- **Step 1:** In the table above, based on the desired features, choose option code character from highlighted options on the left side under the number 18. For example, the option code character “E” has Louver protection and Coil Coating.
- **Step 2:** In the table above, based on the desired features, choose option code character from highlighted options on the left side under the number 19. For example, the option code character “D” has Low Ambient / Freeze Stat and Non-powered convenience outlet.
- **Step 3:** In the table above, based on the desired features, choose option code character from highlighted options on the left side under the number 20. For example, the option code character “3” has Economizer and Return Smoke.
- The resulting option code from examples above is: “ED3”
- **Step 4:** Add your option code selection to the end of model number

◦ Example: RACZT090ACC150AA ED3 = RACDT090ACC150AAED3

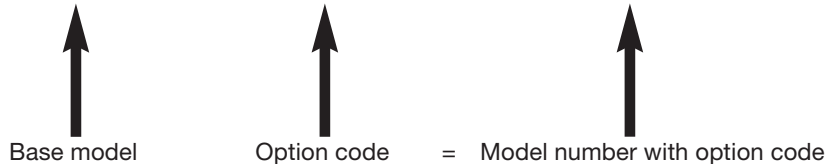

To select an RACDZT Cooling and Heating unit to meet a job requirement, follow this procedure, with example, using data supplied in this specification sheet.

**1. DETERMINE COOLING AND HEATING REQUIREMENTS AND SPECIFIC OPERATING CONDITIONS FROM PLANS AND SPECS.**

**Example:**

Voltage—	230 V – 3 Phase – 60 Hz
Total Cooling Capacity—	118,000 BTUH [34.57 kW]
Sensible Cooling Capacity—	79,600 BTUH [23.32 kW]
Heating Capacity—	150,000 BTUH [40 kW]
*Condenser Entering Air—	95°F [35.0°C] DB
*Evaporator Mixed Air Entering—	65°F [18.3°C] WB
	78°F [25.6°C] DB
*Indoor Air Flow (vertical)—	3600 CFM [1699 L/s]
*External Static Pressure—	0.40 in. WG [.10 kPa]

**2. SELECT UNIT TO MEET COOLING REQUIREMENTS.**

Since total cooling is within the range of a nominal 10 ton [35.1 kW] unit, enter cooling performance table at 95°F [35.0°C] DB condenser inlet air. Interpolate between 63°F [17.2°C] WB and 67°F [19.4°C] to determine total and sensible capacity and power input for 65°F [18.3°C] WB evaporator inlet air at 3750 CFM [1770 L/s] indoor air flow (table basis):

Total Cooling Capacity = 118,900 BTUH [34.82 kW]  
 Sensible Cooling Capacity = 99,950 BTUH [29.27 kW]  
 Power Input (Compressor and Cond. Fans) = 8,950 watts

Use formula  $[1.10 \times \text{CFM} \times (1 - \text{DR}) \times (\text{dbE} - 80)]$  in note to determine sensible capacity at 80°F [26.7°C] DB evaporator entering air:

$99,950 + (1.10 \times 3,600 \times (1 - 0.03) \times (78 - 80))$   
 Sensible Cooling Capacity = 92,268 BTUH [27.02 kW]

**3. CORRECT CAPACITIES OF STEP 2 FOR ACTUAL AIR FLOW.**

Select factors from airflow correction table at 3600 CFM [1699 L/s] and apply to data obtained in step 2 to obtain gross capacity:

Total Capacity =  $118,900 \times 0.98 = 116,522$  BTUH [34.12 kW]  
 Sensible Capacity =  $92,268 \times 0.95 = 87,655$  BTUH [25.67 kW]  
 Power Input =  $8,950 \times 0.99 = 8,861$  Watts

These are Gross Capacities, not corrected for blower motor heat or power.

**4. DETERMINE BLOWER SPEED AND WATTS TO MEET SYSTEM DESIGN.**

Enter Indoor Blower performance table at 3600 CFM [1699 L/s]. Total ESP (external static pressure) per the spec of 0.40 in. WG [.10 kPa] includes the system duct and grilles. Add from the table "Component Air Resistance," 0.076 in. WG [.02 kPa] for wet coil, 0 in. WG [.00 kPa] for downflow air flow for a total selection static pressure of 0.476 (0.5) in. WG [.12 kPa], and determine:

RPM = 771  
 WATTS = 1,494  
 DRIVE = A (Belt drive, low static)

**5. CALCULATE INDOOR BLOWER BTUH HEAT EFFECT FROM MOTOR WATTS, STEP 4.**

$$1,576 \times 3.412 = 5,377 \text{ BTUH [1.57 kW]}$$

**6. CALCULATE NET COOLING CAPACITIES, EQUAL TO GROSS CAPACITY, STEP 3, MINUS INDOOR BLOWER MOTOR HEAT.**

$$\text{Net Total Capacity} = 116,522 - 5,377 = 111,145 \text{ BTUH [32.54 kW]}$$

$$\text{Net Sensible Capacity} = 87,655 - 5,377 = 82,278 \text{ BTUH [24.09 kW]}$$

**7. CALCULATE UNIT INPUT AND JOB EER.**

$$\text{Total Power Input} = 8,861 \text{ (step 3)} + 1,576 \text{ (step 4)} = 10,437 \text{ Watts}$$

$$\text{EER} = \frac{\text{Net Total BTUH [kW] (step 6)}}{\text{Power Input, Watts (above)}} = \frac{111,145}{10,437} = 10.65$$

**8. SELECT UNIT HEATING CAPACITY.**

From Heater Kit Table select kW to meet heating capacity requirement; multiply kW x 3412 to convert to BTUH.

Use 40 kW Heater Kit

Heater Kit Model:	Heater Kit Capacity:
RXXJJ-DD40CP	135,120 BTUH [39.6 kW]

Add indoor blower heat effect (step 5) to Heater Kit Capacity to get total heating capacity:

$$135,120 + 5,377 = 140,497 \text{ BTUH [41.1 kW]}$$

**9. CHOOSE MODEL RACDZT120ACA402AA.**

\*NOTE: These operating conditions are typical of a commercial application in a 95°F/79°F [35°C/26°C] design area with indoor design of 76°F [24°C] DB and 50% RH and 10% ventilation air, with the unit roof mounted and centered on the zone it conditions by ducts.

[ ] Designates Metric Conversions

## NOM. SIZES 7.5-12.5 TONS [26.4-44.0 kW] ASHRAE 90.1-2007 COMPLIANT MODELS

Model RACDZT Series	ZT090	ZT102	ZT120	ZT150
<b>Cooling Performance<sup>A</sup></b>				
Gross Cooling Capacity Btu [kW]	88,000 [25.78]	99,000 [29.01]	118,000 [34.57]	148,000 [43.36]
EER	11.2	11.2	11.2	11.0
IEER <sup>B</sup>	14.8	14.8	14.8	14.2
Nominal CFM/AHRI Rated CFM [L/s]	3000/3175 [1416/1498]	3400/3225 [1604/1522]	4000/3480 [1888/1642]	5000/4150 [2360/1959]
AHRI Net Cooling Capacity Btu [kW]	85,000 [24.9]	96,000 [28.13]	114,000 [33.4]	142,000 [41.61]
Net Sensible Capacity Btu [kW]	62,700 [18.37]	68,300 [20.01]	79,600 [23.32]	98,600 [28.89]
Net Latent Capacity Btu [kW]	22,300 [6.53]	27,700 [8.12]	34,400 [10.08]	43,400 [12.72]
Net System Power kW	7.59	8.57	10.18	12.91
<b>Compressor</b>				
No./Type	1/Scroll	1/Scroll	1/Scroll	2/Tandem Scroll
No. Stages	2	2	2	2
<b>Outdoor Sound Rating (dB)<sup>C</sup></b>				
	88	88	88	88
<b>Outdoor Coil - Fin Type</b>				
Tube Type	Louvered	Louvered	Louvered	Louvered
MicroChannel Depth in. [mm]	MicroChannel	MicroChannel	MicroChannel	MicroChannel
Face Area sq. ft. [sq. m]	0.71 [18]	0.81 [20.6]	1 [25.4]	1 [25.4]
Rows / FPI [FPcm]	25.4 [2.36]	25.6 [2.38]	25.6 [2.38]	31.5 [2.93]
	1 / 23 [9]	1 / 23 [9]	1 / 23 [9]	1 / 23 [9]
<b>Indoor Coil - Fin Type</b>				
Tube Type	Louvered	Louvered	Louvered	Louvered
MicroChannel Depth in. [mm]	MicroChannel	MicroChannel	MicroChannel	MicroChannel
Face Area sq. ft. [sq. m]	1 [25.4]	1.26 [32]	1.26 [32]	1 [25.4]
Rows / FPI [FPcm]	11 [1.02]	10.9 [1.01]	10.9 [1.01]	13.8 [1.28]
	1 / 20 [8]	1 / 20 [8]	1 / 20 [8]	2 / 18 [7]
Refrigerant Control	TX Valves	TX Valves	TX Valves	TX Valves
Drain Connection No./Size in. [mm]	1/0.75 [19.05]	1/0.75 [19.05]	1/0.75 [19.05]	1/0.75 [19.05]
<b>Outdoor Fan - Type</b>				
No. Used/Diameter in. [mm]	Propeller	Propeller	Propeller	Propeller
Drive Type/No. Speeds	2/24 [609.6]	2/24 [609.6]	2/24 [609.6]	2/24 [609.6]
CFM [L/s]	Direct/1	Direct/1	Direct/1	Direct/1
No. Motors/HP	8000 [3775]	8000 [3775]	8500 [4011]	9000 [4247]
Motor RPM	2 at 1/5 HP	2 at 1/5 HP	2 at 1/3 HP	2 at 3/4 HP
	820	820	1075	1100
<b>Indoor Fan - Type</b>				
No. Used/Diameter in. [mm]	FC Centrifugal	FC Centrifugal	FC Centrifugal	FC Centrifugal
Drive Type	1/15x15 [381x381]	1/15x15 [381x381]	1/15x15 [381x381]	1/15x15 [381x381]
No. Speeds	Belt (Adjustable)	Belt (Adjustable)	Belt (Adjustable)	Belt (Adjustable)
No. Motors	2	2	2	2
Motor RPM	1	1	1	1
Motor Frame Size	1725	1725	1725	1725
	56	56	56	184
<b>Filter - Type</b>				
Furnished	Disposable	Disposable	Disposable	Disposable
(NO.) Size Recommended in. [mm x mm x mm]	Yes	Yes	Yes	Yes
	(4)2x20x20 [51x508x508]	(4)2x20x20 [51x508x508]	(4)2x20x20 [51x508x508]	(4)2x20x20 [51x508x508]
<b>Refrigerant Charge Oz. [g]</b>				
	100 [2835]	122 [3458]	136 [3856]	186 [5273]
<b>Weights</b>				
Net Weight lbs. [kg]	736 [334]	762 [346]	791 [359]	993 [450]
Ship Weight lbs. [kg]	775 [352]	801 [363]	830 [376]	1032 [468]

See Page 16 for Notes.

[ ] Designates Metric Conversions

**NOTES:**

- A. Cooling Performance is rated at 95° F ambient, 80° F entering dry bulb, 67° F entering wet bulb. Gross capacity does not include the effect of fan motor heat. AHRI capacity is net and includes the effect of fan motor heat. Units are suitable for operation to  $\pm 20\%$  of nominal cfm. Units are certified in accordance with the Unitary Air Conditioner Equipment certification program, which is based on AHRI Standard 340/360.
- B. EER and/or SEER are rated at AHRI conditions and in accordance with DOE test procedures. Integrated Energy Efficiency Ratio (IEER) is rated in accordance with AHRI Standard 340/360.
- C. Outdoor Sound Rating shown is tested in accordance with AHRI Standard 270.

[ ] Designates Metric Conversions

# COOLING PERFORMANCE DATA — RACDZT090A

wBE		ENTERING INDOOR AIR @ 80°F [26.7°C] dbE ①														
		71°F [21.7°C]		67°F [19.4°C]		63°F [17.2°C]		61°F [16.1°C]		59°F [15.0°C]						
CFM [L/s]	DR ①	3600 [1699]	3175 [1498]	2400 [1133]	3600 [1699]	3175 [1498]	2400 [1133]	3600 [1699]	3175 [1498]	2400 [1133]	3600 [1699]	3175 [1498]	2400 [1133]	3600 [1699]	3175 [1498]	2400 [1133]
75 [23.9]	Total BTUH [KW]	107.4 [31.5]	104.9 [30.7]	100.2 [29.4]	101.8 [29.8]	99.4 [29.1]	95.0 [27.8]	97.8 [28.7]	95.5 [28.0]	91.2 [26.7]	96.6 [28.3]	94.3 [27.6]	90.2 [26.4]	96.2 [28.2]	93.9 [27.5]	89.8 [26.3]
	Sens BTUH [KW]	63.0 [18.5]	59.3 [17.4]	52.5 [15.4]	75.6 [22.2]	71.2 [20.9]	63.1 [18.5]	86.0 [25.2]	80.9 [23.7]	71.7 [21.0]	89.9 [26.3]	84.6 [24.8]	75.0 [22.0]	92.7 [27.2]	87.3 [25.6]	77.3 [22.7]
	Power	5.5	5.4	5.3	5.5	5.4	5.3	5.4	5.3	5.2	5.4	5.3	5.2	5.4	5.3	5.2
80 [26.7]	Total BTUH [KW]	104.8 [30.7]	102.3 [30.0]	97.8 [28.6]	99.2 [29.1]	96.8 [28.4]	92.5 [27.1]	95.2 [27.9]	92.9 [27.2]	88.8 [26.0]	94.0 [27.5]	91.8 [26.9]	87.7 [25.7]	93.6 [27.4]	91.3 [26.8]	87.3 [25.6]
	Sens BTUH [KW]	61.8 [18.1]	58.2 [17.1]	51.6 [15.1]	74.5 [21.8]	70.1 [20.5]	62.1 [18.2]	84.8 [24.9]	79.8 [23.4]	70.7 [20.7]	88.8 [26.0]	83.5 [24.5]	74.0 [21.7]	91.6 [26.8]	86.2 [25.3]	76.4 [22.4]
	Power	5.8	5.7	5.6	5.7	5.7	5.5	5.7	5.6	5.5	5.6	5.6	5.5	5.6	5.5	5.4
85 [29.4]	Total BTUH [KW]	102.0 [29.9]	99.6 [29.2]	95.2 [27.9]	96.4 [28.3]	94.1 [27.6]	90.0 [26.4]	92.4 [27.1]	90.2 [26.4]	86.2 [25.3]	91.2 [26.7]	89.1 [26.1]	85.1 [24.9]	90.8 [26.6]	88.7 [26.0]	84.7 [24.8]
	Sens BTUH [KW]	60.5 [17.7]	57.0 [16.7]	50.5 [14.8]	73.2 [21.4]	68.9 [20.2]	61.0 [17.9]	83.5 [24.5]	78.6 [23.0]	69.7 [20.4]	87.5 [25.6]	82.3 [24.1]	72.9 [21.4]	90.3 [26.5]	85.0 [24.9]	75.3 [22.1]
	Power	6.0	6.0	5.8	6.0	6.0	5.8	5.9	5.9	5.7	5.9	5.8	5.7	5.9	5.8	5.7
90 [32.2]	Total BTUH [KW]	99.2 [29.1]	96.8 [28.4]	92.5 [27.1]	93.5 [27.4]	91.3 [26.8]	87.3 [25.6]	89.5 [26.2]	87.4 [25.6]	83.5 [24.5]	88.4 [25.9]	86.3 [25.3]	82.4 [24.2]	87.9 [25.8]	85.8 [25.2]	82.0 [24.0]
	Sens BTUH [KW]	59.1 [17.3]	55.6 [16.3]	49.3 [14.4]	71.8 [21.0]	67.5 [19.8]	59.8 [17.5]	82.1 [24.1]	77.3 [22.6]	68.5 [20.1]	86.1 [25.2]	81.0 [23.7]	71.8 [21.0]	87.9 [25.8]	83.7 [24.5]	74.1 [21.7]
	Power	6.3	6.3	6.1	6.3	6.2	6.1	6.2	6.2	6.0	6.2	6.1	6.0	6.2	6.1	6.0
95 [35]	Total BTUH [KW]	96.2 [28.2]	93.9 [27.5]	89.7 [26.3]	90.5 [26.5]	88.4 [25.9]	84.5 [24.8]	86.5 [25.4]	84.5 [24.8]	80.7 [23.7]	85.4 [25.0]	83.3 [24.4]	79.6 [23.3]	84.9 [24.9]	82.9 [24.3]	79.2 [23.2]
	Sens BTUH [KW]	57.6 [16.9]	54.2 [15.9]	48.0 [14.1]	70.2 [20.6]	66.1 [19.4]	58.6 [17.2]	80.6 [23.6]	75.8 [22.2]	67.2 [19.7]	84.5 [24.8]	79.5 [23.3]	70.5 [20.7]	84.9 [24.9]	82.2 [24.1]	72.8 [21.3]
	Power	6.7	6.6	6.4	6.6	6.5	6.4	6.6	6.5	6.4	6.5	6.5	6.3	6.5	6.4	6.3
100 [37.8]	Total BTUH [KW]	93.0 [27.3]	90.8 [26.6]	86.8 [25.4]	87.4 [25.6]	85.3 [25.0]	81.6 [23.9]	83.4 [24.4]	81.4 [23.9]	77.8 [22.8]	82.2 [24.1]	80.3 [23.5]	76.7 [22.5]	81.8 [24.0]	79.9 [23.4]	76.3 [22.4]
	Sens BTUH [KW]	55.9 [16.4]	52.6 [15.4]	46.6 [13.7]	68.6 [20.1]	64.5 [18.9]	57.2 [16.8]	78.9 [23.1]	74.3 [21.8]	65.8 [19.3]	82.2 [24.1]	78.0 [22.8]	69.1 [20.2]	81.8 [24.0]	79.9 [23.4]	71.5 [20.9]
	Power	7.0	7.0	6.8	7.0	6.9	6.7	6.9	6.8	6.7	6.9	6.8	6.7	6.9	6.8	6.6
105 [40.6]	Total BTUH [KW]	89.8 [26.3]	87.6 [25.7]	83.7 [24.5]	84.2 [24.7]	82.2 [24.1]	78.5 [23.0]	80.1 [23.5]	78.2 [22.9]	74.8 [21.9]	79.0 [23.1]	77.1 [22.6]	73.7 [21.6]	78.5 [23.0]	76.7 [22.5]	73.3 [21.5]
	Sens BTUH [KW]	54.1 [15.9]	50.9 [14.9]	45.1 [13.2]	66.8 [19.6]	62.8 [18.4]	55.7 [16.3]	77.1 [22.6]	72.6 [21.3]	64.3 [18.8]	79.0 [23.1]	76.3 [22.4]	67.6 [19.8]	78.5 [23.0]	76.7 [22.5]	70.0 [20.5]
	Power	7.4	7.3	7.1	7.3	7.3	7.1	7.3	7.2	7.1	7.3	7.2	7.0	7.3	7.2	7.0
110 [43.3]	Total BTUH [KW]	86.4 [25.3]	84.3 [24.7]	80.6 [23.6]	80.8 [23.7]	78.9 [23.1]	75.4 [22.1]	76.8 [22.5]	74.9 [22.0]	71.6 [21.0]	75.6 [22.2]	73.8 [21.6]	70.5 [20.7]	75.2 [22.0]	73.4 [21.5]	70.1 [20.5]
	Sens BTUH [KW]	52.2 [15.3]	49.1 [14.4]	43.5 [12.8]	64.8 [19.0]	61.0 [17.9]	54.1 [15.8]	75.2 [22.0]	70.8 [20.7]	62.7 [18.4]	75.6 [22.2]	73.8 [21.6]	66.0 [19.3]	75.2 [22.0]	73.4 [21.5]	68.4 [20.0]
	Power	7.8	7.7	7.5	7.7	7.7	7.5	7.7	7.6	7.4	7.7	7.6	7.4	7.7	7.4	
115 [46.1]	Total BTUH [KW]	82.9 [24.3]	80.9 [23.7]	77.3 [22.7]	77.3 [22.6]	75.4 [22.1]	72.1 [21.1]	73.3 [21.5]	71.5 [21.0]	68.4 [20.0]	72.1 [21.1]	70.4 [20.6]	67.3 [19.7]	71.7 [21.0]	70.0 [20.5]	66.9 [19.6]
	Sens BTUH [KW]	50.1 [14.7]	47.2 [13.8]	41.8 [12.3]	62.8 [18.4]	59.1 [17.3]	52.4 [15.3]	73.1 [21.4]	68.8 [20.2]	61.0 [17.9]	72.1 [21.1]	70.4 [20.6]	64.3 [18.8]	71.7 [21.0]	70.0 [20.5]	66.6 [19.5]
	Power	8.2	8.1	7.9	8.2	8.1	7.9	8.1	8.0	7.9	8.1	8.0	7.8	8.1	8.0	7.8
120 [48.9]	Total BTUH [KW]	79.3 [23.2]	77.4 [22.7]	74.0 [21.7]	73.7 [21.6]	71.9 [21.1]	68.7 [20.1]	69.6 [20.4]	68.0 [19.9]	65.0 [19.0]	68.5 [20.1]	66.9 [19.6]	63.9 [18.7]	68.0 [19.9]	66.4 [19.5]	63.5 [18.6]
	Sens BTUH [KW]	48.0 [14.1]	45.1 [13.2]	40.0 [11.7]	60.6 [17.8]	57.0 [16.7]	50.5 [14.8]	69.6 [20.4]	66.8 [19.6]	59.2 [17.3]	68.5 [20.1]	66.9 [19.6]	62.5 [18.3]	68.0 [19.9]	66.4 [19.5]	63.5 [18.6]
	Power	8.7	8.6	8.4	8.6	8.5	8.3	8.6	8.5	8.3	8.6	8.5	8.3	8.5	8.4	8.2
125 [51.7]	Total BTUH [KW]	75.5 [22.1]	73.7 [21.6]	70.5 [20.6]	69.9 [20.5]	68.3 [20.0]	65.2 [19.1]	65.9 [19.3]	64.3 [18.9]	61.5 [18.0]	64.7 [19.0]	63.2 [18.5]	60.4 [17.7]	64.3 [18.8]	62.8 [18.4]	60.0 [17.6]
	Sens BTUH [KW]	45.7 [13.4]	43.0 [12.6]	38.1 [11.2]	58.3 [17.1]	54.9 [16.1]	48.6 [14.2]	65.9 [19.3]	64.3 [18.9]	57.3 [16.8]	64.7 [19.0]	63.2 [18.5]	60.4 [17.7]	64.3 [18.8]	62.8 [18.4]	60.0 [17.6]
	Power	9.1	9.0	8.8	9.1	9.0	8.8	9.0	8.9	8.8	9.0	8.9	8.7	9.0	8.9	8.7

DR — Depression ratio  
 dbE — Entering air dry bulb  
 wBE — Entering air wet bulb

[ ] Designates Metric Conversions

Total — Total capacity x 1000 BTUH  
 Sens — Sensible capacity x 1000 BTUH  
 Power — KW input

NOTES: ① When the entering air dry bulb is other than 80°F [27°C], adjust the sensible capacity from the table by adding [1.10 x CFM x (1 - DR) x (dbE - 80)].

# COOLING PERFORMANCE DATA — RACDZT102A

WIDE CFM [L/s]		ENTERING INDOOR AIR @ 80°F [26.7°C] dBE ①											
		71°F [21.7°C]		67°F [19.4°C]		63°F [17.2°C]		61°F [16.1°C]		59°F [15.0°C]			
		4100 [1935]	3200 [1510]	2700 [1274]	4100 [1935]	3200 [1510]	2700 [1274]	4100 [1935]	3200 [1510]	2700 [1274]	4100 [1935]	3200 [1510]	2700 [1274]
75 [23.9]	Total BTUH [KW]	128.7 [37.7]	122.4 [35.9]	118.9 [34.9]	115.6 [33.6]	111.4 [32.6]	108.2 [31.7]	116.3 [34.1]	110.6 [32.4]	107.5 [31.5]	116.7 [34.2]	111.1 [32.5]	107.9 [31.6]
	Sens BTUH [KW]	74.7 [21.9]	66.0 [19.3]	61.2 [17.9]	59.7 [26.3]	58.4 [17.1]	57.3 [16.8]	56.2 [16.5]	59.5 [32.1]	56.8 [28.4]	55.7 [28.1]	59.8 [33.6]	57.1 [32.7]
	Power	6.2	6.0	5.9	6.1	6.0	5.9	6.0	5.9	5.8	6.0	5.8	5.8
80 [26.7]	Total BTUH [KW]	124.4 [36.5]	118.4 [34.7]	115.0 [33.7]	111.5 [32.7]	108.4 [31.8]	104.3 [30.6]	112.0 [32.8]	106.6 [31.2]	103.6 [30.3]	112.5 [33.0]	107.0 [31.4]	104.0 [30.5]
	Sens BTUH [KW]	72.6 [21.3]	64.1 [18.8]	59.5 [17.4]	57.6 [25.7]	56.2 [16.8]	55.1 [16.5]	54.0 [16.2]	57.4 [31.5]	54.7 [27.8]	53.6 [27.5]	57.5 [33.0]	54.8 [32.1]
	Power	6.5	6.4	6.3	6.5	6.3	6.2	6.4	6.2	6.1	6.3	6.2	6.1
85 [29.4]	Total BTUH [KW]	120.2 [35.2]	114.3 [33.5]	111.1 [32.6]	107.5 [31.5]	104.4 [30.6]	100.3 [29.3]	107.8 [31.6]	102.6 [30.1]	99.6 [29.2]	108.3 [31.7]	103.0 [30.2]	100.1 [29.3]
	Sens BTUH [KW]	70.4 [20.6]	62.2 [18.2]	57.7 [16.9]	55.6 [25.0]	54.1 [20.5]	52.9 [20.2]	51.8 [20.0]	55.2 [30.8]	52.5 [27.3]	51.4 [27.0]	55.3 [30.5]	52.6 [29.6]
	Power	6.9	6.7	6.7	6.8	6.6	6.5	6.7	6.6	6.5	6.7	6.6	6.5
90 [32.2]	Total BTUH [KW]	115.9 [34.0]	110.3 [32.3]	107.2 [31.4]	103.4 [30.3]	100.5 [29.5]	96.4 [28.3]	103.5 [30.3]	98.5 [28.9]	95.7 [28.0]	104.0 [30.5]	98.9 [29.0]	96.1 [28.2]
	Sens BTUH [KW]	68.2 [20.0]	60.3 [17.7]	55.9 [16.4]	53.3 [24.4]	51.8 [20.0]	50.6 [20.0]	49.5 [20.0]	52.9 [30.2]	50.1 [26.7]	49.0 [26.4]	52.8 [30.5]	50.1 [29.6]
	Power	7.3	7.2	7.1	7.3	7.1	7.0	7.2	7.0	6.9	7.1	7.0	6.9
95 [35]	Total BTUH [KW]	111.6 [32.7]	106.2 [31.1]	103.2 [30.2]	99.4 [29.1]	96.6 [28.3]	92.5 [27.9]	99.3 [29.1]	94.4 [27.7]	91.7 [26.9]	99.7 [29.2]	94.9 [27.8]	92.2 [27.0]
	Sens BTUH [KW]	66.0 [19.3]	58.4 [17.1]	54.1 [15.9]	51.7 [23.8]	50.4 [19.5]	49.2 [19.5]	48.1 [19.5]	51.8 [29.1]	49.1 [26.1]	48.0 [26.1]	51.5 [29.2]	48.8 [28.3]
	Power	7.8	7.6	7.5	7.7	7.4	7.4	7.6	7.4	7.3	7.6	7.4	7.3
100 [37.8]	Total BTUH [KW]	107.4 [31.5]	102.1 [29.9]	99.2 [29.1]	95.3 [27.9]	92.6 [27.1]	88.5 [25.9]	95 [27.8]	90.3 [26.5]	87.8 [25.7]	95.4 [28.0]	90.8 [26.6]	88.2 [25.9]
	Sens BTUH [KW]	63.8 [18.7]	56.4 [16.5]	52.3 [15.3]	49.8 [23.1]	48.6 [18.9]	47.5 [18.9]	46.4 [18.9]	49.7 [27.8]	47.2 [25.5]	46.1 [25.5]	49.6 [28.0]	46.9 [27.1]
	Power	8.3	8.1	7.9	8.2	8.0	7.9	8.1	7.9	7.8	8.1	7.9	7.8
105 [40.6]	Total BTUH [KW]	103.0 [30.2]	98.0 [28.7]	95.3 [27.9]	91.5 [26.8]	88.6 [26.0]	84.5 [24.8]	90.7 [26.6]	86.2 [25.3]	83.8 [24.6]	91.1 [26.7]	86.7 [25.4]	84.2 [24.7]
	Sens BTUH [KW]	61.5 [18.0]	54.3 [15.9]	50.4 [14.8]	47.6 [22.4]	46.2 [18.4]	45.1 [18.4]	44.0 [18.4]	47.6 [26.6]	45.1 [24.9]	44.0 [24.9]	47.5 [26.7]	44.8 [24.4]
	Power	8.8	8.6	8.4	8.7	8.4	8.4	8.6	8.4	8.3	8.6	8.4	8.2
110 [43.3]	Total BTUH [KW]	98.7 [28.9]	93.9 [27.5]	91.3 [26.7]	87.1 [25.5]	84.6 [24.8]	80.5 [23.6]	86.3 [25.3]	82.1 [24.1]	79.8 [23.4]	86.8 [25.4]	82.6 [24.2]	80.2 [23.5]
	Sens BTUH [KW]	59.1 [17.3]	52.3 [15.3]	48.5 [14.2]	45.8 [21.7]	44.6 [17.8]	43.5 [17.8]	42.4 [17.8]	45.3 [25.3]	42.8 [24.0]	41.7 [24.0]	45.2 [25.4]	42.5 [24.5]
	Power	9.3	9.1	9.0	9.2	8.9	8.8	9.1	8.9	8.8	9.1	8.9	8.8
115 [46.1]	Total BTUH [KW]	94.4 [27.7]	89.8 [26.3]	87.2 [25.6]	83.0 [24.3]	80.6 [23.6]	76.5 [22.4]	82.0 [24.0]	78.0 [22.9]	75.8 [22.2]	82.5 [24.2]	78.5 [23.0]	76.2 [22.3]
	Sens BTUH [KW]	56.8 [16.6]	50.2 [14.7]	46.5 [13.6]	43.8 [20.0]	42.6 [17.2]	41.5 [17.2]	40.4 [17.2]	43.2 [24.0]	40.7 [22.9]	39.6 [22.9]	43.0 [24.2]	40.3 [23.3]
	Power	9.9	9.6	9.5	9.8	9.4	9.4	9.5	9.3	9.2	9.5	9.3	9.2
120 [48.9]	Total BTUH [KW]	90.0 [26.4]	85.7 [25.1]	83.2 [24.4]	78.8 [23.1]	76.6 [22.4]	72.5 [21.2]	77.7 [22.8]	73.9 [21.6]	71.8 [21.0]	74.3 [21.8]	70.2 [20.6]	68.2 [20.0]
	Sens BTUH [KW]	54.3 [15.9]	48.0 [14.1]	44.5 [13.0]	41.8 [20.0]	40.6 [16.7]	39.5 [16.7]	38.4 [16.7]	41.2 [22.8]	38.7 [21.6]	37.6 [21.6]	41.0 [21.8]	38.2 [21.2]
	Power	10.5	10.2	10.1	10.4	10.0	10.0	10.3	10.1	9.9	10.3	10.0	9.9
125 [51.7]	Total BTUH [KW]	85.7 [25.1]	81.5 [23.9]	79.2 [23.2]	74.7 [21.9]	72.5 [21.3]	68.5 [20.1]	73.3 [21.5]	69.7 [20.4]	67.7 [19.9]	73.8 [21.6]	70.2 [20.6]	68.2 [20.0]
	Sens BTUH [KW]	51.9 [15.2]	45.9 [13.4]	42.5 [12.5]	39.2 [17.3]	38.1 [16.1]	37.0 [16.1]	35.9 [16.1]	38.7 [21.5]	36.6 [20.4]	35.5 [20.4]	38.6 [21.6]	35.9 [20.6]
	Power	11.1	10.9	10.7	11.1	10.8	10.6	11.0	10.7	10.5	10.9	10.7	10.5

DR —Depression ratio  
 dBE —Entering air dry bulb  
 wBE —Entering air wet bulb

[ ] Designates Metric Conversions

Total —Total capacity x 1000 BTUH  
 Sens —Sensible capacity x 1000 BTUH  
 Power —KW input

NOTES: ① When the entering air dry bulb is other than 80°F [27°C], adjust the sensible capacity from the table by adding [1.10 x CFM x (1 – DR) x (dBE – 80)].



# COOLING PERFORMANCE DATA — RACDZT120A

wBE		ENTERING INDOOR AIR @ 80°F [26.7°C] dbE ①														
		71°F [21.7°C]			67°F [19.4°C]			63°F [17.2°C]			61°F [16.1°C]			59°F [15.0°C]		
CFM [L/s]	DR ①	4800 [2265]	3480 [1642]	3200 [1510]	4800 [2265]	3480 [1642]	3200 [1510]	4800 [2265]	3480 [1642]	3200 [1510]	4800 [2265]	3480 [1642]	3200 [1510]	4800 [2265]	3480 [1642]	3200 [1510]
75 [23.9]	Total BTUH [kW]	158.0 [46.3]	147.8 [43.3]	145.6 [42.7]	150.4 [44.1]	140.7 [41.2]	138.6 [40.6]	145.2 [42.6]	135.8 [39.8]	133.9 [39.2]	143.9 [42.2]	134.7 [39.5]	132.7 [38.9]	143.8 [42.1]	134.5 [39.4]	132.6 [38.8]
	Sens BTUH [kW]	101.3 [29.7]	86.1 [25.2]	82.8 [24.3]	120.6 [35.3]	102.4 [30.0]	98.6 [28.9]	138.3 [40.5]	117.5 [34.4]	113.1 [33.1]	143.9 [42.2]	124.3 [36.4]	119.6 [35.1]	143.8 [42.1]	130.4 [38.2]	125.5 [36.8]
	Power	7.5	7.3	7.2	7.4	7.2	7.1	7.3	7.1	7.1	7.3	7.1	7.0	7.3	7.0	7.0
80 [26.7]	Total BTUH [kW]	153.2 [44.9]	143.4 [42.0]	141.3 [41.4]	145.6 [42.7]	136.2 [39.9]	134.2 [39.3]	140.5 [41.2]	135.9 [39.8]	129.5 [37.9]	139.2 [40.8]	130.2 [38.2]	128.3 [37.6]	139.1 [40.8]	130.1 [38.1]	128.2 [37.6]
	Sens BTUH [kW]	98.8 [29.0]	84.0 [24.6]	80.8 [23.7]	118.1 [34.6]	100.3 [29.4]	96.6 [28.3]	135.9 [39.8]	115.4 [33.8]	111.1 [32.6]	139.2 [40.8]	122.2 [35.8]	117.6 [34.5]	139.1 [40.8]	128.3 [37.6]	123.4 [36.2]
	Power	8.0	7.7	7.6	7.9	7.6	7.6	7.8	7.5	7.5	7.7	7.5	7.4	7.7	7.4	7.4
85 [29.4]	Total BTUH [kW]	148.5 [43.5]	138.9 [40.7]	136.9 [40.1]	140.9 [41.3]	131.8 [38.6]	129.9 [38.1]	135.8 [39.8]	127.0 [37.2]	125.1 [36.7]	134.5 [39.4]	125.8 [36.9]	124.0 [36.3]	134.4 [39.4]	125.7 [36.8]	123.9 [36.3]
	Sens BTUH [kW]	96.3 [28.2]	81.8 [24.0]	78.8 [23.1]	115.6 [33.9]	98.2 [28.8]	94.5 [27.7]	133.3 [39.1]	113.3 [33.2]	109.0 [32.0]	134.5 [39.4]	120.1 [35.2]	115.6 [33.9]	134.4 [39.4]	125.7 [36.8]	121.4 [35.6]
	Power	8.4	8.1	8.1	8.3	8.0	8.0	8.2	8.0	7.9	8.2	7.9	7.9	8.1	7.9	7.8
90 [32.2]	Total BTUH [kW]	143.8 [42.1]	134.5 [39.4]	132.6 [38.8]	136.2 [39.9]	127.4 [37.3]	125.5 [36.8]	131.1 [38.4]	122.6 [35.9]	120.8 [35.4]	129.8 [38.0]	121.4 [35.6]	119.6 [35.1]	129.7 [38.0]	121.3 [35.5]	119.5 [35.0]
	Sens BTUH [kW]	93.8 [27.5]	79.7 [23.3]	76.7 [22.5]	113.0 [33.1]	96.0 [28.1]	92.4 [27.1]	130.8 [38.3]	111.1 [32.6]	106.9 [31.3]	129.8 [38.0]	117.9 [34.5]	113.5 [33.3]	129.7 [38.0]	121.3 [35.5]	119.3 [35.0]
	Power	8.9	8.6	8.5	8.8	8.5	8.5	8.7	8.4	8.4	8.7	8.4	8.3	8.6	8.3	8.3
95 [35]	Total BTUH [kW]	139.1 [40.8]	130.2 [38.1]	128.2 [37.6]	131.5 [38.5]	123.0 [36.1]	121.2 [35.5]	126.4 [37.0]	118.2 [34.6]	116.5 [34.1]	125.1 [36.7]	117.0 [34.3]	115.3 [33.8]	125.0 [36.6]	116.9 [34.3]	115.2 [33.8]
	Sens BTUH [kW]	91.2 [26.7]	77.5 [22.7]	74.6 [21.8]	110.4 [32.4]	93.8 [27.5]	90.3 [26.5]	126.4 [37.0]	108.9 [31.9]	104.8 [30.7]	125.1 [36.7]	115.7 [33.9]	111.3 [32.6]	125.0 [36.6]	116.9 [34.3]	115.2 [33.8]
	Power	9.4	9.1	9.0	9.3	9.0	9.0	9.2	8.9	8.9	9.2	8.9	8.8	9.1	8.8	8.8
100 [37.8]	Total BTUH [kW]	134.5 [39.4]	125.8 [36.9]	123.9 [36.3]	126.8 [37.2]	118.7 [34.8]	116.9 [34.3]	121.7 [35.7]	113.8 [33.4]	112.2 [32.9]	120.4 [35.3]	112.7 [33.0]	111.0 [32.5]	120.3 [35.3]	112.5 [33.0]	110.9 [32.5]
	Sens BTUH [kW]	88.5 [25.9]	75.2 [22.0]	72.4 [21.2]	107.8 [31.6]	91.6 [26.8]	88.1 [25.8]	121.7 [35.7]	106.7 [31.3]	102.7 [30.1]	120.4 [35.3]	112.7 [33.0]	109.2 [32.0]	120.3 [35.3]	112.5 [33.0]	110.9 [32.5]
	Power	10.0	9.6	9.6	9.9	9.5	9.5	9.8	9.5	9.4	9.7	9.4	9.3	9.7	9.4	9.3
105 [40.6]	Total BTUH [kW]	129.8 [38.0]	121.4 [35.6]	119.6 [35.1]	122.2 [35.8]	114.3 [33.5]	112.6 [33.0]	117.0 [34.3]	109.5 [32.1]	107.9 [31.6]	115.8 [33.9]	108.3 [31.7]	106.7 [31.3]	115.6 [33.9]	108.2 [31.7]	106.6 [31.2]
	Sens BTUH [kW]	85.9 [25.2]	73.0 [21.4]	70.2 [20.6]	105.1 [30.8]	89.3 [26.2]	86.0 [25.2]	117.0 [34.3]	104.4 [30.6]	100.5 [29.4]	115.8 [33.9]	108.3 [31.7]	106.7 [31.3]	115.6 [33.9]	108.2 [31.7]	106.6 [31.2]
	Power	10.5	10.2	10.1	10.5	10.1	10.0	10.4	10.0	10.0	10.3	10.0	9.9	10.3	9.9	9.9
110 [43.3]	Total BTUH [kW]	125.1 [36.7]	117.1 [34.3]	115.4 [33.8]	117.5 [34.4]	109.9 [32.2]	108.3 [31.7]	112.4 [32.9]	105.1 [30.8]	103.6 [30.4]	111.1 [32.6]	104.0 [30.5]	102.4 [30.0]	111.0 [32.5]	103.8 [30.4]	102.3 [30.0]
	Sens BTUH [kW]	83.1 [24.4]	70.6 [20.7]	68.0 [19.9]	102.4 [30.0]	87.0 [25.5]	83.7 [24.5]	112.4 [32.9]	102.1 [29.9]	98.3 [28.8]	111.1 [32.6]	104.0 [30.5]	102.4 [30.0]	111.0 [32.5]	103.8 [30.4]	102.3 [30.0]
	Power	11.2	10.8	10.7	11.1	10.7	10.6	11.0	10.6	10.5	10.9	10.6	10.5	10.9	10.5	10.5
115 [46.1]	Total BTUH [kW]	120.5 [35.3]	112.7 [33.0]	111.1 [32.6]	112.9 [33.1]	105.6 [31.0]	104.1 [30.5]	107.8 [31.6]	100.8 [29.5]	99.3 [29.1]	106.5 [31.2]	99.6 [29.2]	98.2 [28.8]	106.4 [31.2]	99.5 [29.2]	98.0 [28.7]
	Sens BTUH [kW]	80.4 [23.6]	68.3 [20.0]	65.7 [19.3]	99.7 [29.2]	84.7 [24.8]	81.5 [23.9]	107.8 [31.6]	99.8 [29.2]	96.0 [28.1]	106.5 [31.2]	99.6 [29.2]	98.2 [28.8]	106.4 [31.2]	99.5 [29.2]	98.0 [28.7]
	Power	11.8	11.4	11.3	11.7	11.3	11.3	11.6	11.2	11.2	11.6	11.2	11.1	11.5	11.2	11.1
120 [48.9]	Total BTUH [kW]	115.9 [34.0]	108.4 [31.8]	106.8 [31.3]	108.3 [31.7]	101.3 [29.7]	99.8 [29.3]	103.1 [30.2]	96.5 [28.3]	95.1 [27.9]	101.9 [29.9]	95.3 [27.9]	93.9 [27.5]	101.7 [29.8]	95.2 [27.9]	93.8 [27.5]
	Sens BTUH [kW]	77.6 [22.7]	65.9 [19.3]	63.5 [18.6]	96.9 [28.4]	82.3 [24.1]	79.2 [23.2]	103.1 [30.2]	96.5 [28.3]	93.7 [27.5]	101.9 [29.9]	95.3 [27.9]	93.9 [27.5]	101.7 [29.8]	95.2 [27.9]	93.8 [27.5]
	Power	12.5	12.1	12.0	12.4	12.0	11.9	12.3	11.9	11.8	12.3	12.3	11.8	12.2	11.8	11.7
125 [51.7]	Total BTUH [kW]	111.3 [32.6]	104.1 [30.5]	102.6 [30.1]	103.7 [30.4]	97.0 [28.4]	95.6 [28.0]	98.5 [28.9]	92.2 [27.0]	90.8 [26.6]	97.3 [28.5]	91.0 [26.7]	89.7 [26.3]	97.1 [28.5]	90.9 [26.6]	89.5 [26.2]
	Sens BTUH [kW]	74.8 [21.9]	63.5 [18.6]	61.1 [17.9]	94.0 [27.6]	79.9 [23.4]	76.9 [22.5]	98.5 [28.9]	92.2 [27.0]	90.8 [26.6]	97.3 [28.5]	91.0 [26.7]	89.7 [26.3]	97.1 [28.5]	90.9 [26.6]	89.5 [26.2]
	Power	13.2	12.8	12.7	13.1	12.7	12.6	13.0	12.6	12.5	13.0	12.5	12.5	12.9	12.5	12.4

DR — Depression ratio  
 dbE — Entering air dry bulb  
 wBE — Entering air wet bulb

NOTES: ① When the entering air dry bulb is other than 80°F [27°C], adjust the sensible capacity from the table by adding [1.10 x CFM x (1 - DR) x (dbE - 80)].

## [ ] Designates Metric Conversions

Total — Total capacity x 1000 BTUH  
 Sens — Sensible capacity x 1000 BTUH  
 Power — kW input

# COOLING PERFORMANCE DATA — RACDZT150A

wBE		ENTERING INDOOR AIR @ 80°F [26.7°C] dbE ①													
		71°F [21.7°C]			67°F [19.4°C]			63°F [17.2°C]			3000 [1416]				
CFM [L/s]		4500 [2124]	3000 [1416]	0	3750 [1770]	0.01	0.09	4500 [2124]	3000 [1416]	0	3750 [1770]	0.01	4500 [2124]	3000 [1416]	0.09
75 [23.9]	Total BTUH [kW]	179.6 [52.6]	167.0 [48.9]	0	173.3 [50.8]	166.2 [48.7]	160.2 [46.9]	172.2 [50.5]	160.2 [46.9]	0	166.2 [48.7]	160.2 [46.9]	167.3 [49.0]	160.2 [46.9]	155.5 [45.6]
	Sens BTUH [kW]	113.4 [33.2]	82.6 [24.2]	0	97.4 [28.5]	113.8 [33.3]	97.7 [28.6]	131.0 [38.4]	97.7 [28.6]	0	113.8 [33.3]	97.7 [28.6]	147.4 [43.2]	97.7 [28.6]	111.5 [32.7]
	Power	10.2	9.9	0	10.0	9.9	9.8	10.1	9.8	0	9.9	9.8	10.0	9.8	9.7
80 [26.7]	Total BTUH [kW]	175.0 [51.3]	162.8 [47.7]	0	168.9 [49.5]	161.8 [47.4]	155.9 [45.7]	167.6 [49.1]	155.9 [45.7]	0	161.8 [47.4]	155.9 [45.7]	162.7 [47.7]	155.9 [45.7]	151.3 [44.3]
	Sens BTUH [kW]	110.9 [32.5]	80.9 [23.7]	0	95.3 [27.9]	111.7 [32.7]	95.9 [28.1]	128.5 [37.7]	95.9 [28.1]	0	111.7 [32.7]	95.9 [28.1]	144.9 [42.5]	95.9 [28.1]	109.8 [32.2]
	Power	10.6	10.3	0	10.4	10.4	10.2	10.5	10.2	0	10.4	10.2	10.4	10.2	10.1
85 [29.4]	Total BTUH [kW]	170.5 [50.0]	158.5 [46.4]	0	164.5 [48.2]	157.4 [46.1]	151.6 [44.4]	163.1 [47.8]	151.6 [44.4]	0	157.4 [46.1]	151.6 [44.4]	158.1 [46.3]	151.6 [44.4]	147.0 [43.1]
	Sens BTUH [kW]	108.5 [31.8]	79.1 [23.2]	0	93.2 [27.3]	109.6 [32.1]	94.1 [27.6]	126.1 [36.9]	94.1 [27.6]	0	109.6 [32.1]	94.1 [27.6]	142.4 [41.7]	94.1 [27.6]	108.0 [31.6]
	Power	11.1	10.7	0	10.9	10.8	10.6	11.0	10.6	0	10.8	10.6	10.9	10.6	10.5
90 [32.2]	Total BTUH [kW]	165.9 [48.6]	154.3 [45.2]	0	160.1 [46.9]	153.0 [44.8]	147.4 [42.0]	158.5 [46.4]	147.4 [42.0]	0	153.0 [44.8]	147.4 [42.0]	153.5 [45.0]	147.4 [42.0]	142.8 [41.8]
	Sens BTUH [kW]	105.8 [31.0]	77.2 [22.6]	0	91.0 [26.7]	107.4 [31.5]	92.3 [27.0]	123.4 [36.2]	92.3 [27.0]	0	107.4 [31.5]	92.3 [27.0]	139.7 [40.9]	92.3 [27.0]	106.2 [31.1]
	Power	11.6	11.2	0	11.4	11.3	11.1	11.5	11.1	0	11.3	11.1	11.4	11.1	11.0
95 [35]	Total BTUH [kW]	161.4 [47.3]	150.0 [43.9]	0	155.7 [45.6]	148.6 [43.5]	143.2 [42.0]	154.0 [45.1]	143.2 [42.0]	0	148.6 [43.5]	143.2 [42.0]	149.0 [43.7]	143.2 [42.0]	138.5 [40.6]
	Sens BTUH [kW]	103.3 [30.3]	75.3 [22.1]	0	88.8 [26.0]	105.2 [30.8]	90.5 [26.5]	120.9 [35.4]	90.5 [26.5]	0	105.2 [30.8]	90.5 [26.5]	137.2 [40.2]	90.5 [26.5]	104.3 [30.6]
	Power	12.1	11.6	0	11.9	11.8	11.6	12.0	11.6	0	11.8	11.6	11.9	11.6	11.5
100 [37.8]	Total BTUH [kW]	156.8 [45.9]	145.8 [42.7]	0	151.3 [44.3]	144.2 [42.3]	139.0 [40.7]	149.4 [43.8]	139.0 [40.7]	0	144.2 [42.3]	139.0 [40.7]	144.5 [42.3]	139.0 [40.7]	134.3 [39.3]
	Sens BTUH [kW]	100.6 [29.5]	73.4 [21.5]	0	86.5 [25.3]	102.9 [30.1]	88.6 [26.0]	118.2 [34.6]	88.6 [26.0]	0	102.9 [30.1]	88.6 [26.0]	134.6 [39.4]	88.6 [26.0]	102.4 [30.0]
	Power	12.6	12.2	0	12.4	12.3	12.1	12.5	12.1	0	12.3	12.1	12.4	12.1	12.0
105 [40.6]	Total BTUH [kW]	152.3 [44.6]	141.6 [41.5]	0	147.0 [43.1]	139.8 [41.0]	134.8 [39.5]	144.9 [42.5]	134.8 [39.5]	0	139.8 [41.0]	134.8 [39.5]	139.9 [41.0]	134.8 [39.5]	130.1 [38.1]
	Sens BTUH [kW]	98.0 [28.7]	71.5 [20.9]	0	84.3 [24.7]	100.6 [29.5]	86.7 [25.4]	115.6 [33.9]	86.7 [25.4]	0	100.6 [29.5]	86.7 [25.4]	131.9 [38.6]	86.7 [25.4]	100.5 [29.4]
	Power	13.2	12.7	0	13.0	12.9	12.6	13.1	12.6	0	12.9	12.6	13.0	12.6	12.5
110 [43.3]	Total BTUH [kW]	147.8 [43.3]	137.4 [40.3]	0	142.6 [41.8]	135.5 [39.7]	130.6 [38.3]	140.4 [41.1]	130.6 [38.3]	0	135.5 [39.7]	130.6 [38.3]	135.4 [39.7]	130.6 [38.3]	125.9 [36.9]
	Sens BTUH [kW]	95.3 [27.9]	69.6 [20.4]	0	82.0 [24.0]	98.4 [28.8]	84.8 [24.8]	112.9 [33.1]	84.8 [24.8]	0	98.4 [28.8]	84.8 [24.8]	129.2 [37.9]	84.8 [24.8]	98.6 [28.9]
	Power	13.8	13.3	0	13.5	13.5	13.2	13.7	13.2	0	13.5	13.2	13.6	13.2	13.1
115 [46.1]	Total BTUH [kW]	143.3 [42.0]	133.3 [39.1]	0	138.3 [40.5]	131.2 [38.4]	126.4 [37.0]	135.9 [39.8]	126.4 [37.0]	0	131.2 [38.4]	126.4 [37.0]	130.9 [38.4]	126.4 [37.0]	121.8 [35.7]
	Sens BTUH [kW]	92.6 [27.1]	67.7 [19.8]	0	79.7 [23.4]	96.0 [28.1]	82.7 [24.2]	110.1 [32.3]	82.7 [24.2]	0	96.0 [28.1]	82.7 [24.2]	126.4 [37.0]	82.7 [24.2]	96.6 [28.3]
	Power	14.4	13.9	0	14.2	14.1	13.8	14.3	13.8	0	14.1	13.8	14.2	13.8	13.7

DR — Depression ratio  
 dbE — Entering air dry bulb  
 wBE — Entering air wet bulb

NOTES: ① When the entering air dry bulb is other than 80°F [27°C], adjust the sensible capacity from the table by adding [1.10 x CFM x (1 - DR) x (dbE - 80)].

[ ] Designates Metric Conversions

## GROSS SYSTEMS PERFORMANCE DATA (LOW REHEAT MODE)—RACDZT090

		ENTERING INDOOR AIR @ 75°F [23.9°C] dbE ①									
wbE		65.3°F [18.5°C]			64°F [17.8°C]			62.5°F [16.9°C]			
CFM [L/s]		1800 [850]	1700 [802]	1200 [566]	1800 [850]	1700 [802]	1200 [566]	1800 [850]	1700 [802]	1200 [566]	
OUTDOOR DRY BULB TEMPERATURE °F [°C]	60 [15.6]	Total BTUH [kW]	29.7 [8.7]	29.4 [8.6]	27.9 [8.2]	27.0 [7.9]	26.7 [7.8]	25.3 [7.4]	26.6 [7.8]	26.4 [7.7]	24.9 [7.3]
		Sens BTUH [kW]	6.5 [1.9]	6.3 [1.8]	5.4 [1.6]	9.0 [2.6]	8.7 [2.6]	7.5 [2.2]	11.4 [3.4]	11.1 [3.3]	9.6 [2.8]
		Power	3.2	3.1	3.1	3.2	3.2	3.1	3.2	3.2	3.1
	65 [18.3]	Total BTUH [kW]	29.5 [8.6]	29.2 [8.5]	27.6 [8.1]	26.7 [7.8]	26.4 [7.7]	25.0 [7.3]	26.4 [7.7]	26.1 [7.6]	24.7 [7.2]
		Sens BTUH [kW]	5.0 [1.5]	4.9 [1.4]	4.2 [1.2]	7.6 [2.2]	7.4 [2.2]	6.3 [1.9]	10.0 [2.9]	9.7 [2.9]	8.4 [2.5]
		Power	3.2	3.2	3.1	3.3	3.2	3.2	3.2	3.2	3.1
	70 [21.1]	Total BTUH [kW]	28.8 [8.4]	28.5 [8.4]	27.0 [7.9]	26.0 [7.6]	25.8 [7.6]	24.4 [7.1]	25.7 [7.5]	25.4 [7.5]	24.1 [7.1]
Sens BTUH [kW]		3.7 [1.1]	3.6 [1.0]	3.1 [0.9]	6.2 [1.8]	6.0 [1.8]	5.2 [1.5]	8.6 [2.5]	8.4 [2.5]	7.2 [2.1]	
Power		3.2	3.2	3.1	3.3	3.3	3.2	3.3	3.3	3.2	
75 [23.9]	Total BTUH [kW]	27.8 [8.1]	27.5 [8.1]	26.0 [7.6]	25.0 [7.3]	24.7 [7.2]	23.4 [6.9]	24.7 [7.2]	24.4 [7.2]	23.1 [6.8]	
	Sens BTUH [kW]	2.3 [0.7]	2.3 [0.7]	2.0 [0.6]	4.9 [1.4]	4.7 [1.4]	4.1 [1.2]	7.3 [2.1]	7.1 [2.1]	6.1 [1.8]	
	Power	3.3	3.3	3.2	3.4	3.4	3.3	3.4	3.4	3.3	
80 [26.7]	Total BTUH [kW]	26.3 [7.7]	26.0 [7.6]	24.6 [7.2]	23.5 [6.9]	23.3 [6.8]	22.1 [6.5]	23.2 [6.8]	23.0 [6.7]	21.7 [6.4]	
	Sens BTUH [kW]	1.1 [0.3]	1.0 [0.3]	0.9 [0.3]	3.6 [1.0]	3.5 [1.0]	3.0 [0.9]	6.0 [1.8]	5.9 [1.7]	5.1 [1.5]	
	Power	3.4	3.4	3.3	3.5	3.5	3.4	3.5	3.5	3.4	
85 [29.4]	Total BTUH [kW]	24.5 [7.2]	24.2 [7.1]	22.9 [6.7]	21.7 [6.4]	21.5 [6.3]	20.3 [6.0]	21.4 [6.3]	21.1 [6.2]	20.0 [5.9]	
	Sens BTUH [kW]	-0.2 [-0.1]	-0.2 [0.0]	-0.1 [0.0]	2.4 [0.7]	2.3 [0.7]	2.0 [0.6]	4.8 [1.4]	4.7 [1.4]	4.0 [1.2]	
	Power	3.6	3.6	3.5	3.7	3.6	3.6	3.6	3.6	3.5	
90 [32.2]	Total BTUH [kW]	22.2 [6.5]	22.0 [6.4]	20.8 [6.1]	19.5 [5.7]	19.3 [5.6]	18.2 [5.3]	19.1 [5.6]	18.9 [5.5]	17.9 [5.3]	
	Sens BTUH [kW]	-1.3 [-0.4]	-1.3 [-0.4]	-1.1 [-0.3]	1.2 [0.3]	1.1 [0.3]	1.0 [0.3]	3.6 [1.1]	3.5 [1.0]	3.0 [0.9]	
	Power	3.8	3.7	3.6	3.8	3.8	3.7	3.8	3.8	3.7	

## GROSS SYSTEMS PERFORMANCE DATA (HIGH REHEAT MODE)—RACDZT090

		ENTERING INDOOR AIR @ 75°F [23.9°C] dbE ①									
wbE		65.3°F [18.5°C]			64°F [17.8°C]			62.5°F [16.9°C]			
CFM [L/s]		3600 [1699]	2900 [1369]	2400 [1133]	3600 [1699]	2900 [1369]	2400 [1133]	3600 [1699]	2900 [1369]	2400 [1133]	
OUTDOOR DRY BULB TEMPERATURE °F [°C]	60 [15.6]	Total BTUH [kW]	41.7 [12.2]	39.9 [11.7]	38.7 [11.3]	40.1 [11.8]	38.4 [11.3]	37.2 [10.9]	40.0 [11.7]	38.3 [11.2]	37.1 [10.9]
		Sens BTUH [kW]	8.9 [2.6]	8.0 [2.4]	7.4 [2.2]	12.8 [3.7]	11.5 [3.4]	10.5 [3.1]	18.5 [5.4]	16.7 [4.9]	15.3 [4.5]
		Power	5.0	4.9	4.8	4.9	4.8	4.8	4.9	4.8	4.8
	70 [21.1]	Total BTUH [kW]	39.8 [11.7]	38.1 [11.2]	36.9 [10.8]	38.3 [11.2]	36.7 [10.7]	35.5 [10.4]	38.1 [11.2]	36.5 [10.7]	35.4 [10.4]
		Sens BTUH [kW]	5.9 [1.7]	5.3 [1.6]	4.9 [1.4]	9.8 [2.9]	8.8 [2.6]	8.1 [2.4]	15.5 [4.6]	14.0 [4.1]	12.8 [3.8]
		Power	5.1	5.0	4.9	5.1	5.0	4.9	5.0	4.9	4.9
	80 [26.7]	Total BTUH [kW]	36.7 [10.7]	35.1 [10.3]	34.0 [10.0]	35.1 [10.3]	33.7 [9.9]	32.6 [9.6]	35.0 [10.3]	33.5 [9.8]	32.5 [9.5]
Sens BTUH [kW]		2.1 [0.6]	1.9 [0.5]	1.7 [0.5]	5.9 [1.7]	5.3 [1.6]	4.9 [1.4]	11.7 [3.4]	10.5 [3.1]	9.6 [2.8]	
Power		5.4	5.3	5.2	5.3	5.2	5.1	5.3	5.2	5.1	
90 [32.2]	Total BTUH [kW]	32.3 [9.5]	30.9 [9.1]	30.0 [8.8]	30.8 [9.0]	29.5 [8.6]	28.5 [8.4]	30.6 [9.0]	29.3 [8.6]	28.4 [8.3]	
	Sens BTUH [kW]	-2.7 [-0.8]	-2.4 [-0.7]	-2.2 [-0.6]	1.2 [0.3]	1.0 [0.3]	1.0 [0.3]	6.9 [2.0]	6.2 [1.8]	5.7 [1.7]	
	Power	5.8	5.6	5.6	5.7	5.6	5.5	5.7	5.6	5.5	
100 [37.8]	Total BTUH [kW]	26.7 [7.8]	25.5 [7.5]	24.7 [7.3]	25.1 [7.4]	24.1 [7.1]	23.3 [6.8]	25.0 [7.3]	23.9 [7.0]	23.2 [6.8]	
	Sens BTUH [kW]	-8.3 [-2.4]	-7.4 [-2.2]	-6.8 [-2.0]	-4.4 [-1.3]	-4.0 [-1.2]	-3.7 [-1.1]	1.3 [0.4]	1.2 [0.4]	1.1 [0.3]	
	Power	6.3	6.2	6.1	6.2	6.1	6.0	6.2	6.1	6.0	
110 [43.3]	Total BTUH [kW]	19.8 [5.8]	19.0 [5.6]	18.4 [5.4]	18.3 [5.4]	17.5 [5.1]	17.0 [5.0]	18.1 [5.3]	17.4 [5.1]	16.8 [4.9]	
	Sens BTUH [kW]	-14.7 [-4.3]	-13.2 [-3.9]	-12.2 [-3.6]	-10.9 [-3.2]	-9.8 [-2.9]	-9.0 [-2.6]	-5.1 [-1.5]	-4.6 [-1.4]	-4.2 [-1.2]	
	Power	6.9	6.8	6.7	6.9	6.7	6.6	6.9	6.7	6.6	
120 [48.9]	Total BTUH [kW]	11.7 [3.4]	11.2 [3.3]	10.8 [3.2]	10.1 [3.0]	9.7 [2.8]	9.4 [2.8]	10.0 [2.9]	9.6 [2.8]	9.3 [2.7]	
	Sens BTUH [kW]	-22.1 [-6.5]	-19.8 [-5.8]	-18.2 [-5.3]	-18.2 [-5.3]	-16.4 [-4.8]	-15.1 [-4.4]	-12.5 [-3.7]	-11.2 [-3.3]	-10.3 [-3.0]	
	Power	7.8	7.6	7.5	7.7	7.5	7.4	7.7	7.5	7.4	

DR —Depression ratio  
dbE —Entering air dry bulb  
wbE —Entering air wet bulb

Total —Total capacity x 1000 BTUH  
Sens —Sensible capacity x 1000 BTUH  
Power —KW input

NOTES: ① When the entering air dry bulb is other than 75°F [23.9°C], adjust the sensible capacity from the table by adding  $[1.10 \times \text{CFM} \times (1 - \text{DR}) \times (\text{dbE} - 80)]$ .

[ ] Designates Metric Conversions

## GROSS SYSTEMS PERFORMANCE DATA (LOW REHEAT MODE)–RACDZT102

ENTERING INDOOR AIR @ 75°F [23.9°C] dbE ①												
wbE			65.3°F [18.5°C]			64°F [17.8°C]			62.5°F [16.9°C]			
CFM [L/s]			2100 [991]	1700 [802]	1400 [661]	2100 [991]	1700 [802]	1400 [661]	2100 [991]	1700 [802]	1400 [661]	
OUTDOOR DRY BULB TEMPERATURE °F [°C]	60 [15.6]	Total BTUH [kW]	36.6 [10.7]	35.1 [10.3]	33.9 [9.9]	34.5 [10.1]	33.1 [9.7]	32.1 [9.4]	31.9 [9.3]	30.6 [9.0]	29.6 [8.7]	
		Sens BTUH [kW]	7.1 [2.1]	6.4 [1.9]	5.9 [1.7]	9.0 [2.6]	8.1 [2.4]	7.4 [2.2]	10.7 [3.1]	9.7 [2.8]	8.9 [2.6]	
		Power	3.9	3.8	3.7	3.8	3.8	3.7	3.8	3.8	3.7	
	65 [18.3]	Total BTUH [kW]	35.5 [10.4]	34.0 [10.0]	32.9 [9.6]	33.4 [9.8]	32.1 [9.4]	31.0 [9.1]	30.8 [9.0]	30.8 [9.0]	29.5 [8.6]	28.6 [8.4]
		Sens BTUH [kW]	6.1 [1.8]	5.5 [1.6]	5.0 [1.5]	8.0 [2.3]	7.2 [2.1]	6.6 [1.9]	9.7 [2.8]	8.7 [2.6]	8.0 [2.4]	
		Power	3.9	3.8	3.8	3.9	3.8	3.8	3.9	3.8	3.8	
	70 [21.1]	Total BTUH [kW]	34.1 [10.0]	32.7 [9.6]	31.7 [9.3]	32.1 [9.4]	30.8 [9.0]	29.8 [8.7]	29.5 [8.6]	28.3 [8.3]	27.4 [8.0]	
Sens BTUH [kW]		4.8 [1.4]	4.3 [1.3]	4.0 [1.2]	6.7 [2.0]	6.0 [1.8]	5.5 [1.6]	8.5 [2.5]	7.6 [2.2]	7.0 [2.0]		
Power		4.0	3.9	3.9	4.0	3.9	3.9	4.0	3.9	3.9		
75 [23.9]	Total BTUH [kW]	32.7 [9.6]	31.3 [9.2]	30.3 [8.9]	30.6 [9.0]	29.4 [8.6]	28.4 [8.3]	28.0 [8.2]	26.8 [7.9]	26.0 [7.6]		
	Sens BTUH [kW]	3.3 [1.0]	3.0 [0.9]	2.8 [0.8]	5.2 [1.5]	4.7 [1.4]	4.3 [1.3]	7.0 [2.0]	6.3 [1.8]	5.8 [1.7]		
	Power	4.1	4.0	4.0	4.1	4.0	4.0	4.1	4.0	4.0		
80 [26.7]	Total BTUH [kW]	31.0 [9.1]	29.7 [8.7]	28.8 [8.4]	29.0 [8.5]	27.8 [8.1]	26.9 [7.9]	26.3 [7.7]	25.2 [7.4]	24.4 [7.2]		
	Sens BTUH [kW]	1.7 [0.5]	1.5 [0.4]	1.4 [0.4]	3.6 [1.0]	3.2 [0.9]	2.9 [0.9]	5.3 [1.6]	4.8 [1.4]	4.4 [1.3]		
	Power	4.3	4.2	4.1	4.3	4.2	4.1	4.3	4.2	4.1		
85 [29.4]	Total BTUH [kW]	29.1 [8.5]	27.9 [8.2]	27.0 [7.9]	27.1 [7.9]	26.0 [7.6]	25.1 [7.4]	24.4 [7.2]	23.4 [6.9]	22.7 [6.6]		
	Sens BTUH [kW]	-0.2 [-0.1]	-0.2 [-0.1]	-0.2 [-0.1]	1.7 [0.5]	1.5 [0.4]	1.4 [0.4]	3.4 [1.0]	3.1 [0.9]	2.8 [0.8]		
	Power	4.4	4.3	4.3	4.4	4.3	4.3	4.4	4.3	4.3		
90 [32.2]	Total BTUH [kW]	27.1 [7.9]	26.0 [7.6]	25.1 [7.4]	25.0 [7.3]	24.0 [7.0]	23.2 [6.8]	22.4 [6.6]	21.5 [6.3]	20.8 [6.1]		
	Sens BTUH [kW]	-2.3 [-0.7]	-2.1 [-0.6]	-1.9 [-0.6]	-0.4 [-0.1]	-0.4 [-0.1]	-0.4 [-0.1]	1.3 [0.4]	1.2 [0.3]	1.1 [0.3]		
	Power	4.6	4.5	4.4	4.6	4.5	4.4	4.6	4.5	4.4		

## GROSS SYSTEMS PERFORMANCE DATA (HIGH REHEAT MODE)–RACDZT102

ENTERING INDOOR AIR @ 75°F [23.9°C] dbE ①											
wbE			65.3°F [18.5°C]			64°F [17.8°C]			62.5°F [16.9°C]		
CFM [L/s]			4100 [1935]	2900 [1369]	2700 [1274]	4100 [1935]	2900 [1369]	2700 [1274]	4100 [1935]	2900 [1369]	2700 [1274]
OUTDOOR DRY BULB TEMPERATURE °F [°C]	60 [15.6]	Total BTUH [kW]	57.6 [16.9]	53.6 [15.7]	52.9 [15.5]	45.7 [13.4]	42.5 [12.5]	42.0 [12.3]	51.3 [15.0]	47.7 [14.0]	47.1 [13.8]
		Sens BTUH [kW]	12.7 [3.7]	10.7 [3.1]	10.3 [3.0]	14.6 [4.3]	12.2 [3.6]	11.8 [3.5]	20.5 [6.0]	17.2 [5.0]	16.6 [4.9]
		Power	6.6	6.4	6.3	5.2	5.0	5.0	6.3	6.1	6.0
	70 [21.1]	Total BTUH [kW]	52.7 [15.5]	49.1 [14.4]	48.4 [14.2]	40.9 [12.0]	38.0 [11.1]	37.5 [11.0]	46.4 [13.6]	43.2 [12.7]	42.6 [12.5]
		Sens BTUH [kW]	10.1 [3.0]	8.5 [2.5]	8.2 [2.4]	11.9 [3.5]	10.0 [2.9]	9.7 [2.8]	17.9 [5.2]	15.0 [4.4]	14.5 [4.2]
		Power	6.4	6.1	6.1	5.0	4.8	4.8	6.0	5.8	5.8
	80 [26.7]	Total BTUH [kW]	46.3 [13.6]	43.1 [12.6]	42.6 [12.5]	34.5 [10.1]	32.1 [9.4]	31.6 [9.3]	40.0 [11.7]	37.2 [10.9]	36.7 [10.8]
Sens BTUH [kW]		5.6 [1.6]	4.7 [1.4]	4.5 [1.3]	7.4 [2.2]	6.2 [1.8]	6.0 [1.8]	13.3 [3.9]	11.2 [3.3]	10.8 [3.2]	
Power		6.4	6.1	6.1	5.0	4.8	4.8	6.1	5.8	5.8	
90 [32.2]	Total BTUH [kW]	38.4 [11.2]	35.7 [10.5]	35.2 [10.3]	26.5 [7.8]	24.7 [7.2]	24.3 [7.1]	32.1 [9.4]	29.8 [8.7]	29.4 [8.6]	
	Sens BTUH [kW]	-0.9 [-0.3]	-0.7 [-0.2]	-0.7 [-0.2]	0.9 [0.3]	0.8 [0.2]	0.8 [0.2]	6.9 [2.0]	5.8 [1.7]	5.6 [1.6]	
	Power	6.6	6.4	6.4	5.2	5.1	5.0	6.3	6.1	6.1	
100 [37.8]	Total BTUH [kW]	28.9 [8.5]	26.9 [7.9]	26.5 [7.8]	17.0 [5.0]	15.8 [4.6]	15.6 [4.6]	22.6 [6.6]	21.0 [6.1]	20.7 [6.1]	
	Sens BTUH [kW]	-9.2 [-2.7]	-7.7 [-2.3]	-7.5 [-2.2]	-7.4 [-2.2]	-6.2 [-1.8]	-6.0 [-1.8]	-1.5 [-0.4]	-1.2 [-0.4]	-1.2 [-0.4]	
	Power	7.2	6.9	6.9	5.8	5.6	5.5	6.8	6.6	6.6	
110 [43.3]	Total BTUH [kW]	17.9 [5.2]	16.6 [4.9]	16.4 [4.8]	6.0 [1.8]	5.6 [1.6]	5.5 [1.6]	11.5 [3.4]	10.7 [3.1]	10.6 [3.1]	
	Sens BTUH [kW]	-19.5 [-5.7]	-16.3 [-4.8]	-15.8 [-4.6]	-17.7 [-5.2]	-14.8 [-4.3]	-14.3 [-4.2]	-11.7 [-3.4]	-9.8 [-2.9]	-9.5 [-2.8]	
	Power	7.9	7.7	7.6	6.5	6.3	6.3	7.6	7.4	7.3	
120 [48.9]	Total BTUH [kW]	5.3 [1.5]	4.9 [1.4]	4.9 [1.4]	-6.6 [-1.9]	-6.1 [-1.8]	-6.0 [-1.8]	-1.0 [-0.3]	-1.0 [-0.3]	-1.0 [-0.3]	
	Sens BTUH [kW]	-31.6 [-9.3]	-26.5 [-7.8]	-25.7 [-7.5]	-29.8 [-8.7]	-25.0 [-7.3]	-24.2 [-7.1]	-23.9 [-7.0]	-20.0 [-5.9]	-19.4 [-5.7]	
	Power	9.0	8.7	8.6	7.6	7.3	7.3	8.7	8.4	8.3	

DR —Depression ratio  
 dbE —Entering air dry bulb  
 wbE—Entering air wet bulb  
 Total —Total capacity x 1000 BTUH  
 Sens —Sensible capacity x 1000 BTUH  
 Power—KW input

NOTES: ① When the entering air dry bulb is other than 75°F [23.9°C], adjust the sensible capacity from the table by adding  $[1.10 \times \text{CFM} \times (1 - \text{DR}) \times (\text{dbE} - 80)]$ .

[ ] Designates Metric Conversions

## GROSS SYSTEMS PERFORMANCE DATA (LOW REHEAT MODE)—RACDZT120

ENTERING INDOOR AIR @ 75°F [23.9°C] dbE ①											
wbE			65.3°F [18.5°C]			64°F [17.8°C]			62.5°F [16.9°C]		
CFM [L/s]			3000 [1416]	2400 [1133]	2000 [944]	3000 [1416]	2400 [1133]	2000 [944]	3000 [1416]	2400 [1133]	2000 [944]
OUTDOOR DRY BULB TEMPERATURE °F [°C]	60 [15.6]	Total BTUH [kW]	46.5 [13.6]	44.4 [13.0]	43.1 [12.6]	43.1 [12.6]	41.2 [12.1]	40.0 [11.7]	40.3 [11.8]	38.6 [11.3]	37.4 [11.0]
		Sens BTUH [kW]	12.9 [3.8]	11.6 [3.4]	10.7 [3.1]	13.8 [4.0]	12.3 [3.6]	11.4 [3.3]	18.5 [5.4]	16.5 [4.8]	15.3 [4.5]
		Power	4.6	4.5	4.4	4.5	4.4	4.3	4.5	4.4	4.3
	65 [18.3]	Total BTUH [kW]	45.7 [13.4]	43.7 [12.8]	42.4 [12.4]	42.3 [12.4]	40.5 [11.9]	39.3 [11.5]	39.6 [11.6]	37.8 [11.1]	36.7 [10.8]
		Sens BTUH [kW]	10.5 [3.1]	9.4 [2.8]	8.7 [2.5]	11.4 [3.3]	10.2 [3.0]	9.4 [2.8]	16.1 [4.7]	14.4 [4.2]	13.3 [3.9]
		Power	4.6	4.5	4.5	4.6	4.5	4.4	4.5	4.4	4.4
	70 [21.1]	Total BTUH [kW]	44.7 [13.1]	42.7 [12.5]	41.4 [12.1]	41.3 [12.1]	39.5 [11.6]	38.3 [11.2]	38.5 [11.3]	36.9 [10.8]	35.7 [10.5]
Sens BTUH [kW]		8.3 [2.4]	7.4 [2.2]	6.9 [2.0]	9.2 [2.7]	8.2 [2.4]	7.6 [2.2]	13.9 [4.1]	12.4 [3.6]	11.4 [3.4]	
Power		4.7	4.6	4.6	4.7	4.6	4.5	4.6	4.5	4.5	
75 [23.9]	Total BTUH [kW]	43.4 [12.7]	41.5 [12.2]	40.2 [11.8]	40.0 [11.7]	38.3 [11.2]	37.1 [10.9]	37.2 [10.9]	35.6 [10.4]	34.5 [10.1]	
	Sens BTUH [kW]	6.3 [1.8]	5.6 [1.7]	5.2 [1.5]	7.2 [2.1]	6.4 [1.9]	5.9 [1.7]	11.9 [3.5]	10.6 [3.1]	9.8 [2.9]	
	Power	4.9	4.8	4.7	4.8	4.7	4.7	4.8	4.7	4.6	
80 [26.7]	Total BTUH [kW]	41.8 [12.2]	40.0 [11.7]	38.8 [11.4]	38.4 [11.3]	36.8 [10.8]	35.6 [10.4]	35.7 [10.5]	34.1 [10.0]	33.1 [9.7]	
	Sens BTUH [kW]	4.5 [1.3]	4.0 [1.2]	3.7 [1.1]	5.4 [1.6]	4.8 [1.4]	4.4 [1.3]	10.1 [2.9]	9.0 [2.6]	8.3 [2.4]	
	Power	5.1	5.0	4.9	5.0	4.9	4.9	5.0	4.9	4.8	
85 [29.4]	Total BTUH [kW]	40.0 [11.7]	38.2 [11.2]	37.1 [10.9]	36.6 [10.7]	35.0 [10.3]	33.9 [9.9]	33.8 [9.9]	32.4 [9.5]	31.4 [9.2]	
	Sens BTUH [kW]	2.9 [0.8]	2.6 [0.8]	2.4 [0.7]	3.8 [1.1]	3.4 [1.0]	3.1 [0.9]	8.5 [2.5]	7.6 [2.2]	7.0 [2.0]	
	Power	5.4	5.3	5.2	5.3	5.2	5.1	5.3	5.2	5.1	
90 [32.2]	Total BTUH [kW]	37.9 [11.1]	36.2 [10.6]	35.1 [10.3]	34.5 [10.1]	33.0 [9.7]	32.0 [9.4]	31.7 [9.3]	30.4 [8.9]	29.4 [8.6]	
	Sens BTUH [kW]	1.5 [0.4]	1.3 [0.4]	1.2 [0.4]	2.4 [0.7]	2.1 [0.6]	2.0 [0.6]	7.1 [2.1]	6.3 [1.9]	5.8 [1.7]	
	Power	5.7	5.6	5.5	5.6	5.5	5.4	5.6	5.5	5.4	

## GROSS SYSTEMS PERFORMANCE DATA (HIGH REHEAT MODE)—RACDZT120

ENTERING INDOOR AIR @ 75°F [23.9°C] dbE ①											
wbE			65.3°F [18.5°C]			64°F [17.8°C]			62.5°F [16.9°C]		
CFM [L/s]			4800 [2265]	3800 [1793]	3200 [1510]	4800 [2265]	3800 [1793]	3200 [1510]	4800 [2265]	3800 [1793]	3200 [1510]
OUTDOOR DRY BULB TEMPERATURE °F [°C]	60 [15.6]	Total BTUH [kW]	58.1 [17.0]	55.4 [16.2]	53.9 [15.8]	55.5 [16.3]	53.0 [15.5]	51.4 [15.1]	53.1 [15.6]	50.7 [14.9]	49.2 [14.4]
		Sens BTUH [kW]	10.5 [3.1]	9.3 [2.7]	8.6 [2.5]	15.6 [4.6]	13.9 [4.1]	12.9 [3.8]	19.9 [5.8]	17.7 [5.2]	16.4 [4.8]
		Power	7.0	6.9	6.8	6.9	6.8	6.7	6.9	6.8	6.7
	70 [21.1]	Total BTUH [kW]	53.4 [15.7]	51.0 [14.9]	49.5 [14.5]	50.8 [14.9]	48.5 [14.2]	47.1 [13.8]	48.4 [14.2]	46.2 [13.5]	44.9 [13.2]
		Sens BTUH [kW]	8.3 [2.4]	7.4 [2.2]	6.8 [2.0]	13.4 [3.9]	12.0 [3.5]	11.1 [3.2]	17.7 [5.2]	15.8 [4.6]	14.6 [4.3]
		Power	7.1	7.0	6.9	7.0	6.9	6.8	7.0	6.9	6.8
	80 [26.7]	Total BTUH [kW]	48.4 [14.2]	46.2 [13.5]	44.9 [13.2]	45.8 [13.4]	43.7 [12.8]	42.5 [12.4]	43.4 [12.7]	41.5 [12.1]	40.3 [11.8]
Sens BTUH [kW]		4.5 [1.3]	4.0 [1.2]	3.7 [1.1]	9.7 [2.8]	8.6 [2.5]	8.0 [2.3]	14.0 [4.1]	12.5 [3.6]	11.5 [3.4]	
Power		7.4	7.3	7.2	7.3	7.2	7.1	7.3	7.2	7.1	
90 [32.2]	Total BTUH [kW]	43.1 [12.6]	41.1 [12.0]	39.9 [11.7]	40.5 [11.9]	38.6 [11.3]	37.5 [11.0]	38.1 [11.2]	36.3 [10.6]	35.3 [10.3]	
	Sens BTUH [kW]	-0.8 [-0.2]	-0.7 [-0.2]	-0.6 [-0.2]	4.4 [1.3]	3.9 [1.1]	3.6 [1.1]	8.7 [2.5]	7.7 [2.3]	7.2 [2.1]	
	Power	7.9	7.7	7.6	7.8	7.7	7.5	7.8	7.6	7.5	
100 [37.8]	Total BTUH [kW]	37.4 [11.0]	35.7 [10.5]	34.6 [10.2]	34.8 [10.2]	33.2 [9.7]	32.2 [9.4]	32.4 [9.5]	30.9 [9.1]	30.0 [8.8]	
	Sens BTUH [kW]	-7.6 [-2.2]	-6.8 [-2.0]	-6.3 [-1.8]	-2.5 [-0.7]	-2.2 [-0.6]	-2.0 [-0.6]	1.8 [0.5]	1.6 [0.5]	1.5 [0.4]	
	Power	8.6	8.4	8.3	8.5	8.3	8.2	8.5	8.3	8.2	
110 [43.3]	Total BTUH [kW]	31.3 [9.2]	29.9 [8.8]	29.0 [8.5]	28.7 [8.4]	27.4 [8.0]	26.6 [7.8]	26.3 [7.7]	25.1 [7.4]	24.4 [7.1]	
	Sens BTUH [kW]	-16.0 [-4.7]	-14.3 [-4.2]	-13.2 [-3.9]	-10.9 [-3.2]	-9.7 [-2.8]	-9.0 [-2.6]	-6.6 [-1.9]	-5.9 [-1.7]	-5.5 [-1.6]	
	Power	9.5	9.3	9.2	9.4	9.2	9.1	9.4	9.2	9.0	
120 [48.9]	Total BTUH [kW]	24.9 [7.3]	23.8 [7.0]	23.1 [6.8]	22.3 [6.5]	21.3 [6.2]	20.7 [6.1]	19.9 [5.8]	19.0 [5.6]	18.5 [5.4]	
	Sens BTUH [kW]	-26.0 [-7.6]	-23.2 [-6.8]	-21.5 [-6.3]	-20.9 [-6.1]	-18.6 [-5.5]	-17.2 [-5.0]	-16.6 [-4.9]	-14.8 [-4.3]	-13.7 [-4.0]	
	Power	10.6	10.3	10.2	10.5	10.2	10.1	10.5	10.2	10.1	

DR —Depression ratio  
dbE —Entering air dry bulb  
wbE—Entering air wet bulb

Total —Total capacity x 1000 BTUH  
Sens —Sensible capacity x 1000 BTUH  
Power —KW input

NOTES: ① When the entering air dry bulb is other than 75°F [23.9°C], adjust the sensible capacity from the table by adding  $[1.10 \times \text{CFM} \times (1 - \text{DR}) \times (\text{dbE} - 80)]$ .

[ ] Designates Metric Conversions

## GROSS SYSTEMS PERFORMANCE DATA (LOW REHEAT MODE) – RACDZT150

ENTERING INDOOR AIR @ 75°F [23.9°C] dbE ①												
wbE			65.3°F [18.5°C]			64°F [17.8°C]			62.5°F [16.9°C]			
CFM [L/s]			3000 [1416]	2400 [1133]	2000 [944]	3000 [1416]	2400 [1133]	2000 [944]	3000 [1416]	2400 [1133]	2000 [944]	
OUTDOOR DRY BULB TEMPERATURE °F [°C]	60 [15.6]	Total BTUH [kW]	46.5 [13.6]	44.4 [13.0]	43.1 [12.6]	43.1 [12.6]	41.2 [12.1]	40.0 [11.7]	40.3 [11.8]	38.6 [11.3]	37.4 [11.0]	
		Sens BTUH [kW]	12.9 [3.8]	11.6 [3.4]	10.7 [3.1]	13.8 [4.0]	12.3 [3.6]	11.4 [3.3]	18.5 [5.4]	16.5 [4.8]	15.3 [4.5]	
		Power	4.6	4.5	4.4	4.5	4.4	4.3	4.5	4.4	4.3	
	65 [18.3]	Total BTUH [kW]	45.7 [13.4]	43.7 [12.8]	42.4 [12.4]	42.3 [12.4]	40.5 [11.9]	39.3 [11.5]	39.6 [11.6]	39.6 [11.6]	37.8 [11.1]	36.7 [10.8]
		Sens BTUH [kW]	10.5 [3.1]	9.4 [2.8]	8.7 [2.5]	11.4 [3.3]	10.2 [3.0]	9.4 [2.8]	16.1 [4.7]	14.4 [4.2]	13.3 [3.9]	
		Power	4.6	4.5	4.5	4.6	4.5	4.4	4.5	4.4	4.4	
	70 [21.1]	Total BTUH [kW]	44.7 [13.1]	42.7 [12.5]	41.4 [12.1]	41.3 [12.1]	39.5 [11.6]	38.3 [11.2]	38.5 [11.3]	38.5 [11.3]	36.9 [10.8]	35.7 [10.5]
Sens BTUH [kW]		8.3 [2.4]	7.4 [2.2]	6.9 [2.0]	9.2 [2.7]	8.2 [2.4]	7.6 [2.2]	13.9 [4.1]	12.4 [3.6]	11.4 [3.4]		
Power		4.7	4.6	4.6	4.7	4.6	4.5	4.6	4.5	4.5		
75 [23.9]	Total BTUH [kW]	43.4 [12.7]	41.5 [12.2]	40.2 [11.8]	40.0 [11.7]	38.3 [11.2]	37.1 [10.9]	37.2 [10.9]	37.2 [10.9]	35.6 [10.4]	34.5 [10.1]	
	Sens BTUH [kW]	6.3 [1.8]	5.6 [1.7]	5.2 [1.5]	7.2 [2.1]	6.4 [1.9]	5.9 [1.7]	11.9 [3.5]	10.6 [3.1]	9.8 [2.9]		
	Power	4.9	4.8	4.7	4.8	4.7	4.7	4.8	4.7	4.6		
80 [26.7]	Total BTUH [kW]	41.8 [12.2]	40.0 [11.7]	38.8 [11.4]	38.4 [11.3]	36.8 [10.8]	35.6 [10.4]	35.7 [10.5]	35.7 [10.5]	34.1 [10.0]	33.1 [9.7]	
	Sens BTUH [kW]	4.5 [1.3]	4.0 [1.2]	3.7 [1.1]	5.4 [1.6]	4.8 [1.4]	4.4 [1.3]	10.1 [2.9]	9.0 [2.6]	8.3 [2.4]		
	Power	5.1	5.0	4.9	5.0	4.9	4.9	5.0	4.9	4.8		
85 [29.4]	Total BTUH [kW]	40.0 [11.7]	38.2 [11.2]	37.1 [10.9]	36.6 [10.7]	35.0 [10.3]	33.9 [9.9]	33.8 [9.9]	33.8 [9.9]	32.4 [9.5]	31.4 [9.2]	
	Sens BTUH [kW]	2.9 [0.8]	2.6 [0.8]	2.4 [0.7]	3.8 [1.1]	3.4 [1.0]	3.1 [0.9]	8.5 [2.5]	7.6 [2.2]	7.0 [2.0]		
	Power	5.4	5.3	5.2	5.3	5.2	5.1	5.3	5.2	5.1		
90 [32.2]	Total BTUH [kW]	37.9 [11.1]	36.2 [10.6]	35.1 [10.3]	34.5 [10.1]	33.0 [9.7]	32.0 [9.4]	31.7 [9.3]	31.7 [9.3]	30.4 [8.9]	29.4 [8.6]	
	Sens BTUH [kW]	1.5 [0.4]	1.3 [0.4]	1.2 [0.4]	2.4 [0.7]	2.1 [0.6]	2.0 [0.6]	7.1 [2.1]	6.3 [1.9]	5.8 [1.7]		
	Power	5.7	5.6	5.5	5.6	5.5	5.4	5.6	5.5	5.4		

## GROSS SYSTEMS PERFORMANCE DATA (HIGH REHEAT MODE) – RACDZT150

ENTERING INDOOR AIR @ 75°F [23.9°C] dbE ①											
wbE			65.3°F [18.5°C]			64°F [17.8°C]			62.5°F [16.9°C]		
CFM [L/s]			6000 [2832]	4100 [1935]	4000 [1888]	6000 [2832]	4100 [1935]	4000 [1888]	6000 [2832]	4100 [1935]	4000 [1888]
OUTDOOR DRY BULB TEMPERATURE °F [°C]	60°F [15.6]	Total BTUH [kW]	99.3 [29.1]	91.5 [26.8]	91.1 [26.7]	101.6 [29.8]	93.7 [27.4]	93.2 [27.3]	92.7 [27.2]	85.5 [25.1]	85.2 [25.0]
		Sens BTUH [kW]	33.3 [9.7]	27.4 [8.0]	27.0 [7.9]	40.1 [11.8]	33.0 [9.7]	32.6 [9.6]	46.4 [13.6]	38.1 [11.2]	37.7 [11.0]
		Power	9.5	9.1	9.1	9.3	8.9	8.9	9.3	8.9	8.9
	70°F [21.1]	Total BTUH [kW]	94.4 [27.7]	87.1 [25.5]	86.7 [25.4]	96.7 [28.3]	89.2 [26.1]	88.8 [26.0]	87.9 [25.8]	81.1 [23.8]	80.7 [23.7]
		Sens BTUH [kW]	27 [7.9]	22.2 [6.5]	21.9 [6.4]	33.9 [9.9]	27.9 [8.2]	27.5 [8.1]	40.1 [11.7]	33.0 [9.7]	32.6 [9.5]
		Power	9.7	9.3	9.3	9.5	9.2	9.2	9.5	9.2	9.1
	80°F [26.7]	Total BTUH [kW]	87.6 [25.7]	80.8 [23.7]	80.4 [23.6]	89.9 [26.3]	82.9 [24.3]	82.5 [24.2]	81.1 [23.8]	74.8 [21.9]	74.4 [21.8]
Sens BTUH [kW]		20.1 [5.9]	16.5 [4.8]	16.3 [4.8]	27.0 [7.9]	22.2 [6.5]	21.9 [6.4]	33.2 [9.7]	27.3 [8.0]	27.0 [7.9]	
Power		10.2	9.8	9.8	10.0	9.6	9.6	10.0	9.6	9.6	
90°F [32.2]	Total BTUH [kW]	78.7 [23.1]	72.6 [21.3]	72.3 [21.2]	81.0 [23.7]	74.7 [21.9]	74.4 [21.8]	72.2 [21.2]	66.6 [19.5]	66.3 [19.4]	
	Sens BTUH [kW]	12.5 [3.7]	10.3 [3.0]	10.2 [3.0]	19.4 [5.7]	15.9 [4.7]	15.8 [4.6]	25.6 [7.5]	21.0 [6.2]	20.8 [6.1]	
	Power	11.0	10.5	10.5	10.8	10.4	10.3	10.8	10.3	10.3	
100°F [37.8]	Total BTUH [kW]	67.8 [19.9]	62.5 [18.3]	62.3 [18.2]	70.1 [20.5]	64.7 [18.9]	64.4 [18.9]	61.3 [18.0]	56.5 [16.6]	56.3 [16.5]	
	Sens BTUH [kW]	4.3 [1.3]	3.5 [1.0]	3.5 [1.0]	11.2 [3.3]	9.2 [2.7]	9.1 [2.7]	17.4 [5.1]	14.3 [4.2]	14.1 [4.1]	
	Power	11.9	11.5	11.4	11.8	11.3	11.3	11.8	11.3	11.3	
110 [43.3]	Total BTUH [kW]	54.9 [16.1]	50.6 [14.8]	50.4 [14.8]	57.2 [16.8]	52.7 [15.5]	52.5 [15.4]	48.4 [14.2]	44.6 [13.1]	44.4 [13.0]	
	Sens BTUH [kW]	-4.6 [-1.3]	-3.8 [-1.1]	-3.7 [-1.1]	2.3 [0.7]	1.9 [0.5]	1.9 [0.5]	8.5 [2.5]	7.0 [2.0]	6.9 [2.0]	
	Power	13.2	12.6	12.6	13.0	12.5	12.4	13.0	12.5	12.4	
120 [48.9]	Total BTUH [kW]	40.0 [11.7]	36.8 [10.8]	36.7 [10.8]	42.3 [12.4]	39.0 [11.4]	38.8 [11.4]	33.4 [9.8]	30.8 [9.0]	30.7 [9.0]	
	Sens BTUH [kW]	-14.1 [-4.1]	-11.6 [-3.4]	-11.5 [-3.4]	-7.2 [-2.1]	-6.0 [-1.7]	-5.9 [-1.7]	-1.0 [-0.3]	-0.9 [-0.2]	-0.8 [-0.2]	
	Power	14.6	14.1	14.0	14.5	13.9	13.9	14.4	13.9	13.8	

DR — Depression ratio  
dbE — Entering air dry bulb  
wbE — Entering air wet bulb

Total — Total capacity x 1000 BTUH  
Sens — Sensible capacity x 1000 BTUH  
Power — kW input

NOTES: ① When the entering air dry bulb is other than 75°F [23.9°C], adjust the sensible capacity from the table by adding  $[1.10 \times \text{CFM} \times (1 - \text{DR}) \times (\text{dbE} - 80)]$ .

[ ] Designates Metric Conversions



# AIRFLOW PERFORMANCE— 7.5 TON [26.4 kW] — 60 Hz — DOWNFLOW

Air Flow CFM [L/s]	Model RACDZ*090* Voltage 208/230, 460, 575 — 3 phase 60 Hz																																							
	External Static Pressure—Inches of Water [kPa]																																							
	0.1 [0.02]	0.2 [0.05]	0.3 [0.07]	0.4 [0.10]	0.5 [0.12]	0.6 [0.15]	0.7 [0.17]	0.8 [0.20]	0.9 [0.22]	1.0 [0.25]	1.1 [0.27]	1.2 [0.30]	1.3 [0.32]	1.4 [0.35]	1.5 [0.37]	1.6 [0.40]	1.7 [0.42]	1.8 [0.45]	1.9 [0.47]	2.0 [0.50]																				
2400 [1133]	—	551	782	585	814	619	848	652	885	684	926	717	969	748	1016	780	1065	810	1118	841	1174	870	1233	900	1294	929	1359	957	1427	985	1498	1012	1572	1039	1649	1065	1729	1091	1813	
2500 [1180]	—	562	816	596	848	629	884	661	923	693	964	725	1009	756	1057	787	1108	817	1162	846	1219	876	1279	904	1343	933	1409	960	1478	987	1550	1014	1626	1040	1704	1066	1786	1092	1870	
2600 [1227]	—	574	851	607	885	639	922	671	962	702	1006	733	1052	764	1101	794	1153	823	1209	852	1267	881	1329	909	1393	937	1461	964	1531	990	1605	1016	1682	1042	1762	1067	1844	1092	1930	
2700 [1274]	553	857	585	889	618	925	650	963	681	1004	712	1049	742	1096	772	1147	801	1201	830	1258	858	1317	886	1380	914	1446	941	1515	967	1587	993	1662	1019	1740	1044	1821	1068	1905	1092	1993
2800 [1321]	565	896	597	930	629	966	660	1006	691	1049	721	1095	751	1144	780	1196	808	1251	837	1309	864	1370	892	1434	919	1501	945	1572	971	1645	996	1721	1021	1801	1045	1883	1069	1969	1093	2057
2900 [1368]	577	937	609	972	640	1010	670	1051	701	1096	730	1143	759	1193	788	1246	816	1303	843	1362	871	1425	897	1490	923	1559	949	1630	974	1705	999	1783	1023	1864	1047	1948	1070	2035	1093	2124
3000 [1416]	590	981	621	1017	651	1057	681	1099	710	1145	739	1193	768	1245	796	1300	823	1357	850	1418	877	1482	903	1549	928	1619	953	1692	978	1768	1002	1847	1026	1929	1049	2014	1072	2103	1094	2194
3100 [1463]	602	1027	633	1065	662	1105	692	1149	720	1196	749	1246	777	1299	804	1355	831	1414	857	1476	883	1541	908	1610	933	1681	958	1755	982	1833	1005	1913	1028	1997	1051	2083	1073	2173	1094	2266
3200 [1510]	615	1075	645	1114	674	1157	702	1202	731	1250	758	1301	785	1356	812	1413	838	1473	864	1537	889	1603	914	1673	938	1746	962	1821	986	1900	1008	1982	1031	2067	1053	2155	1074	2246	1095	2340
3300 [1557]	628	1126	657	1166	685	1210	713	1256	741	1306	768	1359	794	1414	820	1473	846	1535	871	1600	896	1668	920	1739	944	1813	967	1890	989	1970	1012	2053	1033	2139	1055	2229	1075	2321	1096	2416
3400 [1604]	640	1179	669	1221	697	1266	724	1314	751	1365	777	1419	803	1476	829	1536	854	1599	878	1665	902	1734	926	1807	949	1882	971	1960	993	2042	1015	2126	1036	2214	1057	2305	1077	2398	1097	2495
3500 [1652]	653	1235	681	1278	708	1324	735	1373	761	1425	787	1481	812	1539	837	1601	861	1665	885	1733	909	1803	932	1877	954	1954	976	2034	997	2116	1018	2202	1039	2291	1059	2383	1078	2478	1097	2576
3600 [1699]	666	1292	693	1337	720	1384	746	1435	771	1489	797	1545	821	1605	845	1668	869	1734	892	1803	915	1875	938	1950	959	2028	981	2109	1001	2193	1022	2280	1042	2371	1061	2464	1080	2560	1098	2660

**NOTE: A/F-Drive left of the bold line, B/G-Drive right of bold lines, C/H-Drive right of double line.**

Drive Package	A/F	B/G										C/H																										
Motor H.P. [W]	2 [1491.4]	3 [2237.1]										3 [2237.1]																										
Blower Sheave	AK84H	AK84H										AK84H																										
Motor Sheave	1VL40*7/8	1VP50*7/8										1VP56*7/8																										
Belt	A49	A50										A51																										
Turns Open	0	1	2	3	4	5	0	1	2	3	4	5	0	1	2	3	4	5	0	1	2	3	4	5	0	1	2	3	4	5	0	1	2	3	4	5		
RPM	767	721	<b>678</b>	635	590	548	992	949	908	866	823	782	1108	1067	1029	987	946	905	864	823	782	741	700	659	618	577	536	495	454	413	372	331	290	249	208	167	126	85

- NOTES: 1. Factory sheave settings are shown in bold type.  
 2. Do not set motor sheave below minimum or maximum turns open shown.  
 3. Re-adjustment of sheave required to achieve rated airflow at AHRI minimum External Static Pressure  
 4. Add component resistance (below) to duct resistance to determine total External Static Pressure.

[ ] Designates Metric Conversions



**AIRFLOW PERFORMANCE— 7.5 TON [26.4 kW] — 60 Hz — DOWNFLOW (Con't.)**

Airflow	AIRFLOW CORRECTION FACTORS *				COMPONENT AIRFLOW RESISTANCE						
	CFM [L/s]	Total MBH	Sensible MBH	Power kW	Wet Coil	Vertical Economizer RA Damper Open	Resistance — Inches of Water		Concentric Diffuser RXRN-AED2000 & Concentric Adapter RXMC-DD01 (Drop)	Pressure Drop MERV 8	Pressure Drop MERV 13
							Concentric Diffuser RXRN-AEF2000 & Concentric Adapter RXMC-DD01 (Flush)	Concentric Diffuser RXRN-AED2000 & Concentric Adapter RXMC-DD01 (Drop)			
2400 [1133]	0.96	0.89	0.98	0.01 [0.01]	0.01 [0.00]	0.66 [.16]	0.53 [.13]	0.093 [.02]	0.047 [.01]		
2500 [1180]	0.96	0.90	0.99	0.02 [0.01]	0.02 [0.00]	0.71 [.18]	0.57 [.14]	0.098 [.02]	0.055 [.01]		
2600 [1227]	0.97	0.92	0.99	0.02 [0.01]	0.02 [0.01]	0.75 [.19]	0.60 [.15]	0.103 [.02]	0.062 [.01]		
2700 [1274]	0.97	0.93	0.99	0.03 [0.01]	0.03 [0.01]	0.80 [.20]	0.65 [.16]	0.108 [.03]	0.070 [.02]		
2800 [1321]	0.98	0.95	0.99	0.04 [0.01]	0.04 [0.01]	0.85 [.21]	0.69 [.17]	0.113 [.03]	0.078 [.02]		
2900 [1368]	0.98	0.96	1.00	0.04 [0.02]	0.04 [0.01]	0.91 [.23]	0.74 [.18]	0.117 [.03]	0.085 [.02]		
3000 [1416]	0.99	0.97	1.00	0.05 [0.02]	0.05 [0.01]	0.96 [.24]	0.79 [.20]	0.122 [.03]	0.093 [.02]		
3100 [1463]	1.00	0.99	1.00	0.06 [0.02]	0.06 [0.02]	1.02 [.25]	0.86 [.21]	0.127 [.03]	0.100 [.02]		
3200 [1510]	1.00	1.00	1.01	0.07 [0.02]	0.07 [0.02]	1.08 [.27]	0.92 [.23]	0.132 [.03]	0.108 [.03]		
3300 [1557]	1.01	1.02	1.01	0.08 [0.02]	0.08 [0.02]	1.15 [.29]	0.99 [.25]	0.137 [.03]	0.115 [.03]		
3400 [1604]	1.01	1.03	1.01	0.08 [0.02]	0.09 [0.02]	1.21 [.30]	1.05 [.26]	0.142 [.03]	0.123 [.03]		
3500 [1652]	1.02	1.05	1.01	0.09 [0.02]	0.10 [0.02]	1.29 [.32]	1.09 [.27]	0.147 [.04]	0.131 [.03]		
3600 [1699]	1.02	1.06	1.02	0.09 [0.02]	0.11 [0.03]	1.36 [.34]	1.13 [.28]	0.152 [.04]	0.138 [.03]		

\*Multiply correction factor times gross performance data resulting sensible capacity cannot exceed total capacity.

[ ] Designates Metric Conversions

# AIRFLOW PERFORMANCE— 7.5 TON [26.4 kW] — 60 Hz — SIDEFLOW

Air Flow CFM [L/s]	Model RACDZ-090* Voltage 208/230, 460, 575 — 3 phase 60 Hz																																							
	External Static Pressure—Inches of Water [kPa]																																							
	0.1 [0.02]	0.2 [0.05]	0.3 [0.07]	0.4 [0.10]	0.5 [0.12]	0.6 [0.15]	0.7 [0.17]	0.8 [0.20]	0.9 [0.22]	1.0 [0.25]	1.1 [0.27]	1.2 [0.30]	1.3 [0.32]	1.4 [0.35]	1.5 [0.37]	1.6 [0.40]	1.7 [0.42]	1.8 [0.45]	1.9 [0.47]	2.0 [0.50]																				
2400 [1133]	—	—	—	558	822	594	853	629	887	663	925	697	965	730	1009	763	1056	794	1106	826	1159	856	1216	886	1275	915	1338	943	1404	971	1474	998	1546	1025	1622	1051	1700	1076	1782	
2500 [1180]	—	—	—	568	848	604	881	638	917	672	956	705	998	738	1044	769	1092	801	1144	831	1199	861	1258	890	1319	919	1384	947	1452	974	1523	1001	1597	1027	1674	1052	1755	1077	1838	
2600 [1227]	—	—	543	846	579	877	613	912	647	950	681	991	713	1035	745	1082	777	1132	807	1186	837	1243	867	1303	895	1366	923	1433	951	1502	978	1575	1004	1651	1029	1730	1054	1812	1078	1898
2700 [1274]	—	—	554	877	589	910	623	946	657	986	689	1029	722	1074	753	1124	784	1176	814	1231	844	1290	872	1332	901	1417	928	1485	955	1556	981	1631	1007	1708	1032	1789	1056	1873	1079	1961
2800 [1321]	—	—	566	911	600	946	634	984	666	1026	699	1070	730	1118	761	1169	792	1223	821	1280	850	1340	878	1404	906	1470	933	1540	959	1613	985	1690	1010	1769	1034	1852	1058	1938	1081	2027
2900 [1368]	543	916	577	949	611	986	644	1026	676	1069	708	1115	739	1164	770	1217	799	1273	828	1332	857	1394	885	1459	912	1528	938	1599	964	1674	989	1752	1014	1833	1037	1918	1061	2005	1083	2096
3000 [1416]	555	955	589	990	622	1029	655	1070	687	1115	718	1163	748	1214	778	1269	807	1326	836	1387	864	1451	891	1518	918	1588	944	1662	969	1738	994	1818	1017	1901	1041	1987	1063	2077	1085	2169
3100 [1463]	568	998	601	1035	634	1075	666	1118	697	1165	728	1215	758	1268	787	1324	816	1383	844	1445	871	1511	898	1580	924	1652	949	1727	974	1806	998	1887	1022	1972	1044	2060	1066	2151	1088	2245
3200 [1510]	581	1044	614	1083	646	1125	677	1170	708	1218	738	1270	768	1324	796	1382	824	1443	852	1507	879	1575	905	1646	931	1719	955	1796	980	1876	1003	1960	1026	2046	1048	2136	1070	2229	1091	2325
3300 [1557]	594	1093	626	1134	658	1178	689	1225	719	1275	749	1328	778	1384	806	1444	833	1507	860	1573	887	1642	912	1714	937	1790	962	1869	985	1951	1008	2036	1031	2124	1052	2216	1073	2310	1094	2408
3400 [1604]	607	1146	639	1189	670	1234	701	1283	730	1335	759	1390	788	1448	815	1509	843	1574	869	1642	895	1713	920	1787	944	1864	968	1945	991	2028	1014	2115	1036	2205	1057	2298	1077	2395	1097	2494
3500 [1652]	621	1203	652	1247	683	1294	713	1344	742	1398	770	1455	798	1515	825	1578	852	1644	878	1714	903	1786	928	1862	952	1941	975	2024	997	2109	1019	2198	1041	2290	1061	2385	1081	2483	1101	2584
3600 [1699]	635	1262	666	1308	696	1357	725	1409	754	1465	782	1523	809	1585	836	1650	862	1718	887	1789	912	1864	936	1941	959	2022	982	2106	1004	2194	1025	2284	1046	2378	1066	2474	1086	2574	1104	2677

NOTE: A/F-Drive left of the bold line, B/G-Drive right of bold lines, C/H-Drive right of double line.

Drive Package	A/F	B/G	C/H
Motor H.P. [W]	2 [1491.4]	3 [2237.1]	3 [2237.1]
Blower Sheave	AK84H	AK84H	AK84H
Motor Sheave	1VL40*7/8	1VP50*7/8	1VP56*7/8
Belt	A49	A50	A51
Turns Open	0 1 2 3 4 5	0 1 2 3 4 5	0 1 2 3 4 5
RPM	765 720 <b>676</b> 633 589 544	989 949 908 865 823 780	1108 1067 1029 987 946 905

- NOTES: 1. Factory sheave settings are shown in bold type.  
 2. Do not set motor sheave below minimum or maximum turns open shown.  
 3. Re-adjustment of sheave required to achieve rated airflow at AHRI minimum External Static Pressure  
 4. Add component resistance (below) to duct resistance to determine total External Static Pressure.

[ ] Designates Metric Conversions

**AIRFLOW PERFORMANCE— 7.5 TON [26.4 kW] — 60 Hz — SIDEFLOW (Con't.)**

Airflow	AIRFLOW CORRECTION FACTORS *				COMPONENT AIRFLOW RESISTANCE					
	CFM [L/s]	Total MBH	Sensible MBH	Power kW	Wet Coil	Horizontal Economizer RA Damper Open	Resistance — Inches of Water		Pressure Drop MERV 8	Pressure Drop MERV 13
							Concentric Diffuser RXRN-AEF2000 & Concentric Adapter RXMC-DDD1 (Flush)	Concentric Diffuser RXRN-AED2000 & Concentric Adapter RXMC-DDD1 (Drop)		
2400 [1133]	0.96	0.89	0.98		0.04 [01]	0.21 [05]	0.66 [16]	0.53 [13]	0.093 [02]	0.047 [01]
2500 [1180]	0.96	0.90	0.99		0.05 [01]	0.25 [06]	0.71 [18]	0.57 [14]	0.098 [02]	0.055 [01]
2600 [1227]	0.97	0.92	0.99		0.05 [01]	0.28 [07]	0.75 [19]	0.60 [15]	0.103 [02]	0.062 [01]
2700 [1274]	0.97	0.93	0.99		0.05 [01]	0.32 [08]	0.80 [20]	0.65 [16]	0.108 [03]	0.070 [02]
2800 [1321]	0.98	0.95	0.99		0.06 [01]	0.36 [09]	0.85 [21]	0.69 [17]	0.113 [03]	0.078 [02]
2900 [1368]	0.98	0.96	1.00		0.06 [02]	0.39 [10]	0.91 [23]	0.74 [18]	0.117 [03]	0.085 [02]
3000 [1416]	0.99	0.97	1.00		0.07 [02]	0.43 [11]	0.96 [24]	0.79 [20]	0.122 [03]	0.093 [02]
3100 [1463]	1.00	0.99	1.00		0.07 [02]	0.47 [12]	1.02 [25]	0.86 [21]	0.127 [03]	0.100 [02]
3200 [1510]	1.00	1.00	1.01		0.07 [02]	0.51 [13]	1.08 [27]	0.92 [23]	0.132 [03]	0.108 [03]
3300 [1557]	1.01	1.02	1.01		0.08 [02]	0.54 [14]	1.15 [29]	0.99 [25]	0.137 [03]	0.115 [03]
3400 [1604]	1.01	1.03	1.01		0.08 [02]	0.58 [14]	1.21 [30]	1.05 [26]	0.142 [03]	0.123 [03]
3500 [1652]	1.02	1.05	1.01		0.09 [02]	0.62 [15]	1.29 [32]	1.09 [27]	0.147 [04]	0.131 [03]
3600 [1699]	1.02	1.06	1.02		0.09 [02]	0.66 [16]	1.36 [34]	1.13 [28]	0.152 [04]	0.138 [03]

\*Multiply correction factor times gross performance data resulting sensible capacity cannot exceed total capacity.

[ ] Designates Metric Conversions

# AIRFLOW PERFORMANCE—8.5 TON [29.9 kW] — 60 Hz — DOWNFLOW

Air Flow CFM [L/s]	Model RACDZ*102* Voltage 208/230, 460, 575 — 3 phase 60 Hz																							
	External Static Pressure—Inches of Water [kPa]																							
	0.1 [0.02]	0.2 [0.05]	0.3 [0.07]	0.4 [0.10]	0.5 [0.12]	0.6 [0.15]	0.7 [0.17]	0.8 [0.20]	0.9 [0.22]	1.0 [0.25]	1.1 [0.27]	1.2 [0.30]	1.3 [0.32]	1.4 [0.35]	1.5 [0.37]	1.6 [0.40]	1.7 [0.42]	1.8 [0.45]	1.9 [0.47]	2.0 [0.50]				
2700 [127.4]	—	561 [894]	596 [934]	631 [975]	665 [1018]	698 [1062]	730 [1108]	762 [1155]	793 [1203]	823 [1253]	853 [1304]	882 [1357]	910 [1411]	937 [1467]	964 [1524]	990 [1583]	1015 [1643]	1039 [1704]	1063 [1767]	1086 [1832]				
2800 [132.1]	—	573 [927]	608 [969]	642 [1013]	676 [1058]	708 [1104]	740 [1152]	771 [1201]	802 [1252]	832 [1304]	861 [1358]	889 [1413]	917 [1470]	943 [1528]	970 [1587]	995 [1648]	1020 [1711]	1044 [1775]	1067 [1840]	1090 [1907]				
2900 [136.8]	—	586 [964]	620 [1008]	654 [1054]	687 [1101]	719 [1150]	750 [1200]	781 [1252]	811 [1305]	840 [1360]	869 [1416]	897 [1473]	924 [1532]	950 [1593]	976 [1654]	1001 [1718]	1025 [1782]	1048 [1848]	1071 [1916]	1093 [1985]				
3000 [141.6]	564 [959]	599 [1004]	633 [1051]	666 [1099]	698 [1149]	730 [1200]	761 [1253]	791 [1307]	820 [1362]	849 [1419]	877 [1477]	904 [1537]	931 [1598]	957 [1661]	982 [1725]	1006 [1791]	1030 [1858]	1053 [1926]	1075 [1996]	1097 [2067]				
3100 [146.3]	578 [1001]	612 [1048]	645 [1098]	678 [1148]	710 [1200]	741 [1254]	771 [1308]	801 [1365]	830 [1423]	858 [1482]	886 [1542]	912 [1605]	939 [1668]	964 [1733]	989 [1800]	1012 [1868]	1036 [1937]	1058 [2008]	1080 [2080]	1101 [2154]				
3200 [151.0]	592 [1046]	625 [1096]	658 [1148]	690 [1201]	721 [1255]	752 [1311]	782 [1368]	811 [1427]	840 [1487]	867 [1548]	894 [1611]	921 [1676]	946 [1742]	971 [1809]	995 [1878]	1019 [1948]	1041 [2020]	1063 [2093]	1085 [2168]	1105 [2244]				
3300 [155.7]	605 [1096]	638 [1148]	671 [1202]	702 [1257]	733 [1314]	763 [1372]	793 [1432]	821 [1493]	849 [1555]	877 [1619]	903 [1684]	929 [1751]	954 [1819]	979 [1889]	1002 [1960]	1025 [2033]	1047 [2107]	1069 [2182]	1090 [2259]	1110 [2337]				
3400 [160.4]	619 [1149]	652 [1204]	684 [1260]	715 [1317]	745 [1376]	775 [1437]	804 [1499]	832 [1562]	860 [1627]	886 [1693]	912 [1761]	938 [1830]	962 [1900]	986 [1972]	1009 [2046]	1032 [2121]	1053 [2197]	1074 [2275]	1095 [2354]	1114 [2435]				
3500 [165.2]	634 [1206]	666 [1263]	697 [1322]	728 [1382]	758 [1443]	787 [1506]	815 [1570]	843 [1635]	870 [1702]	896 [1771]	922 [1841]	946 [1912]	970 [1985]	994 [2060]	1017 [2135]	1038 [2213]	1060 [2291]	1080 [2371]	1100 [2453]	1119 [2536]				
3600 [169.9]	648 [1267]	680 [1326]	711 [1387]	741 [1449]	770 [1513]	799 [1578]	827 [1645]	854 [1713]	880 [1782]	906 [1853]	931 [1925]	955 [1999]	979 [2074]	1002 [2151]	1024 [2229]	1045 [2308]	1066 [2389]	1086 [2472]	1105 [2556]	1124 [2641]				
3700 [174.6]	663 [1332]	694 [1393]	724 [1456]	754 [1521]	783 [1587]	811 [1654]	838 [1723]	865 [1793]	891 [1865]	916 [1938]	941 [2013]	965 [2089]	988 [2167]	1010 [2246]	1032 [2326]	1053 [2408]	1073 [2491]	1092 [2576]	1111 [2662]	1129 [2750]				
3800 [179.3]	678 [1400]	708 [1464]	738 [1529]	767 [1596]	795 [1665]	823 [1734]	850 [1805]	876 [1878]	902 [1952]	926 [2028]	951 [2105]	974 [2183]	996 [2263]	1018 [2344]	1039 [2427]	1060 [2511]	1080 [2597]	1099 [2684]	1117 [2772]	1134 [2862]				
3900 [184.0]	693 [1472]	723 [1538]	752 [1606]	781 [1675]	808 [1746]	836 [1818]	862 [1892]	888 [1966]	913 [2043]	937 [2121]	961 [2200]	983 [2281]	1005 [2363]	1027 [2447]	1048 [2532]	1067 [2618]	1087 [2706]	1105 [2796]	1123 [2886]	1140 [2979]				
4000 [188.8]	708 [1548]	737 [1617]	766 [1687]	794 [1758]	822 [1831]	848 [1906]	874 [1981]	900 [2059]	924 [2137]	948 [2218]	971 [2299]	993 [2382]	1015 [2467]	1036 [2553]	1056 [2640]	1075 [2729]	1094 [2819]	1112 [2911]	1129 [3004]	1146 [3099]				
4100 [193.5]	723 [1628]	752 [1699]	781 [1771]	808 [1845]	835 [1920]	861 [1997]	887 [2075]	911 [2155]	935 [2236]	959 [2318]	981 [2402]	1003 [2488]	1024 [2574]	1045 [2663]	1064 [2752]	1083 [2844]	1101 [2936]	1119 [3030]	1136 [3126]	1152 [3223]				

NOTE: A/F—Drive left of the bold line, B/G—Drive right of bold lines, C/H—Drive right of double line.

Drive Package	A/F										B/G										C/H			
Motor H.P. [W]	2 [1491.4]										3 [2237.1]										3 [2237.1]			
Blower Sheave	AK79H										AK79H										AK79H			
Motor Sheave	1VL40*7/8										1VP50*7/8										1VP56*7/8			
Belt	A49										A50										A51			
Turns Open	0	1	2	3	4	5	0	1	2	3	4	5	0	1	2	3	4	5	0	1	2	3	4	5
RPM	804	758	710	661	616	559	1048	1003	959	914	872	826	1168	1128	1087	1044	1002	957	916	875	834	793	752	711

- NOTES: 1. Factory sheave settings are shown in bold type.  
 2. Do not set motor sheave below minimum or maximum turns open shown.  
 3. Re-adjustment of sheave required to achieve rated airflow at AHRI minimum External Static Pressure  
 4. Add component resistance (below) to duct resistance to determine total External Static Pressure.

[ ] Designates Metric Conversions

**AIRFLOW PERFORMANCE—8.5 TON [29.9 kW] — 60 Hz — DOWNFLOW (Con't.)**

Airflow	AIRFLOW CORRECTION FACTORS *				COMPONENT AIRFLOW RESISTANCE						
	CFM [L/s]	Total MBH	Sensible MBH	Power kW	Wet Coil	Vertical Economizer RA Damper Open	Resistance — Inches of Water		Concentric Diffuser RXRN-AED2000 & Concentric Adapter RXMC-DD01 (Drop)	Pressure Drop MERV 8	Pressure Drop MERV 13
							Concentric Diffuser RXRN-AEF2000 & Concentric Adapter RXMC-DD01 (Flush)	Concentric Diffuser RXRN-AED2000 & Concentric Adapter RXMC-DD01 (Drop)			
2700 [1274]	0.97	0.93	0.99	0.07 [02]	0.03 [01]	0.80 [20]	0.65 [16]	0.108 [03]	0.070 [02]		
2800 [1321]	0.98	0.94	0.99	0.07 [02]	0.03 [01]	0.85 [21]	0.69 [17]	0.113 [03]	0.078 [02]		
2900 [1368]	0.98	0.96	0.99	0.08 [02]	0.04 [01]	0.91 [23]	0.74 [18]	0.117 [03]	0.085 [02]		
3000 [1416]	0.99	0.97	1.00	0.08 [02]	0.05 [01]	0.96 [24]	0.79 [20]	0.122 [03]	0.093 [02]		
3100 [1463]	0.99	0.99	1.00	0.09 [02]	0.06 [01]	1.02 [25]	0.86 [21]	0.127 [03]	0.100 [02]		
3200 [1510]	1.00	1.00	1.00	0.10 [02]	0.07 [02]	1.08 [27]	0.92 [23]	0.132 [03]	0.108 [03]		
3300 [1557]	1.01	1.01	1.00	0.10 [03]	0.08 [02]	1.15 [29]	0.99 [25]	0.137 [03]	0.115 [03]		
3400 [1604]	1.01	1.03	1.01	0.11 [03]	0.09 [02]	1.21 [30]	1.05 [26]	0.142 [03]	0.123 [03]		
3500 [1652]	1.02	1.04	1.01	0.11 [03]	0.10 [02]	1.29 [32]	1.09 [27]	0.147 [04]	0.131 [03]		
3600 [1699]	1.02	1.06	1.01	0.12 [03]	0.11 [03]	1.36 [34]	1.13 [28]	0.152 [04]	0.138 [03]		
3700 [1746]	1.03	1.07	1.02	0.13 [03]	0.12 [03]	1.43 [36]	1.18 [29]	0.157 [04]	0.146 [04]		
3800 [1793]	1.03	1.09	1.02	0.13 [03]	0.13 [03]	1.50 [37]	1.23 [31]	0.162 [04]	0.153 [04]		
3900 [1840]	1.04	1.10	1.02	0.14 [04]	0.15 [04]	1.59 [40]	1.31 [33]	0.167 [04]	0.161 [04]		
4000 [1888]	1.05	1.12	1.02	0.14 [04]	0.16 [04]	1.68 [42]	1.38 [34]	0.171 [04]	0.169 [04]		
4100 [1935]	1.05	1.13	1.03	0.15 [04]	0.17 [04]	1.74 [43]	1.44 [36]	0.176 [04]	0.176 [04]		

\*Multiply correction factor times gross performance data resulting sensible capacity cannot exceed total capacity.

[ ] Designates Metric Conversions

# AIRFLOW PERFORMANCE—8.5 TON [29.9 kW] — 60 Hz — SIDEFLOW

Air Flow CFM [L/s]	Model RACDZ*102* Voltage 208/230, 460, 575 — 3 phase 60 Hz																																							
	External Static Pressure—Inches of Water [kPa]																																							
	0.1 [0.02]	0.2 [0.05]	0.3 [0.07]	0.4 [0.10]	0.5 [0.12]	0.6 [0.15]	0.7 [0.17]	0.8 [0.20]	0.9 [0.22]	1.0 [0.25]	1.1 [0.27]	1.2 [0.30]	1.3 [0.32]	1.4 [0.35]	1.5 [0.37]	1.6 [0.40]	1.7 [0.42]	1.8 [0.45]	1.9 [0.47]	2.0 [0.50]																				
2700 [127.4]	—	—	577	932	611	969	644	1009	677	1032	710	1098	742	1147	774	1199	806	1254	837	1312	868	1373	898	1437	929	1505	959	1575	988	1648	1017	1725	1046	1804	1074	1886	1102	1972		
2800 [132.1]	—	556	926	589	962	622	1000	655	1042	687	1087	719	1134	751	1185	783	1239	814	1295	844	1355	875	1418	905	1484	934	1553	963	1624	992	1699	1021	1777	1049	1858	1077	1942	1105	2029	
2900 [136.9]	—	568	958	601	995	633	1036	666	1079	697	1125	729	1174	760	1227	791	1282	821	1340	851	1402	881	1466	911	1533	940	1604	968	1677	997	1754	1025	1834	1052	1916	1080	2002	1107	2090	
3000 [141.6]	—	580	994	613	1033	645	1074	676	1119	708	1167	738	1218	769	1272	799	1329	829	1389	859	1452	888	1518	917	1587	945	1659	973	1734	1001	1812	1029	1894	1056	1978	1082	2065	1109	2155	
3100 [146.3]	561	996	593	1033	624	1073	656	1117	687	1163	718	1213	748	1265	778	1321	808	1379	837	1441	866	1506	895	1573	923	1644	951	1718	978	1794	1006	1874	1033	1957	1059	2043	1085	2132	1111	2224
3200 [151.0]	574	1037	605	1076	636	1118	667	1163	698	1211	728	1262	758	1316	787	1373	816	1434	845	1497	873	1563	902	1632	929	1705	957	1780	984	1858	1010	1940	1037	2024	1063	2112	1088	2202	1113	2296
3300 [155.7]	587	1082	618	1122	648	1166	679	1212	709	1262	738	1315	767	1371	796	1430	825	1491	853	1556	881	1624	908	1695	936	1769	962	1846	989	1926	1015	2009	1041	2095	1066	2184	1091	2276	1116	2372
3400 [160.4]	600	1130	630	1172	660	1217	690	1266	720	1317	749	1371	777	1429	806	1489	834	1553	861	1619	888	1689	915	1761	942	1837	968	1916	994	1997	1020	2082	1045	2170	1070	2260	1094	2354	1118	2451
3500 [165.2]	613	1182	643	1226	672	1273	702	1323	730	1376	759	1432	787	1491	815	1553	842	1618	869	1686	896	1757	922	1831	948	1909	974	1989	999	2072	1024	2158	1049	2248	1073	2340	1097	2436	1121	2534
3600 [169.9]	626	1238	656	1283	685	1332	713	1383	741	1438	769	1495	797	1556	824	1620	851	1687	877	1756	904	1829	929	1905	955	1984	980	2066	1005	2151	1029	2238	1053	2329	1077	2423	1100	2520	1123	2621
3700 [174.6]	640	1297	668	1344	697	1394	725	1447	753	1504	780	1563	807	1625	833	1690	860	1759	886	1830	911	1905	937	1982	961	2063	986	2146	1010	2233	1034	2322	1057	2415	1081	2510	1103	2609	1128	2711
3800 [179.3]	653	1360	681	1409	709	1460	737	1515	764	1573	790	1634	817	1698	843	1765	869	1835	894	1908	919	1984	944	2063	968	2145	992	2230	1016	2318	1039	2410	1062	2504	1084	2601	1107	2701	1128	2805
3900 [184.0]	667	1426	694	1471	721	1530	748	1587	775	1646	801	1709	827	1774	852	1843	878	1914	902	1989	927	2067	951	2147	975	2231	998	2318	1021	2408	1044	2500	1066	2596	1088	2695	1110	2797	1131	2902
4000 [188.8]	680	1496	707	1548	734	1604	760	1662	786	1723	812	1787	837	1854	862	1924	887	1998	911	2074	935	2153	958	2235	981	2321	1004	2409	1027	2501	1049	2595	1071	2693	1092	2793	1113	2897	1134	3003
4100 [193.5]	694	1570	720	1624	746	1681	772	1740	797	1803	822	1869	847	1938	872	2009	896	2084	919	2162	943	2243	965	2327	988	2414	1010	2504	1032	2597	1054	2693	1075	2792	1096	2895	1116	3000	1137	3108

NOTE: A/F—Drive left of the bold line, B/G—Drive right of bold lines, C/H—Drive right of double line.

Drive Package	A/F	B/G	C/H
Motor H.P. [W]	2 [1491.4]	3 [2237.1]	3 [2237.1]
Blower Sheave	AK79H	AK79H	AK79H
Motor Sheave	1VL40*7/8	1VP50*7/8	1VP56*7/8
Belt	A49	A50	A51
Turns Open	0	1	2
RPM	802	754	707
		662	616
		555	505
		455	405
		355	305
		255	205
		155	105
		55	5

- NOTES: 1. Factory sheave settings are shown in bold type.  
 2. Do not set motor sheave below minimum or maximum turns open shown.  
 3. Re-adjustment of sheave required to achieve rated airflow at AHRI minimum External Static Pressure  
 4. Add component resistance (below) to duct resistance to determine total External Static Pressure.

[ ] Designates Metric Conversions

**AIRFLOW PERFORMANCE—8.5 TON [29.9 kW] — 60 Hz — SIDEFLOW (Con't.)**

Airflow	AIRFLOW CORRECTION FACTORS *				COMPONENT AIRFLOW RESISTANCE					Pressure Drop MERV 8	Pressure Drop MERV 13
	CFM [L/s]	Total MBH	Sensible MBH	Power kW	Wet Coil	Horizontal Economizer RA Damper Open	Resistance — Inches of Water		Concentric Diffuser RXRN-AED2000 & Concentric Adapter RXMC-DD01 (Drop)		
							Concentric Diffuser RXRN-AEF2000 & Concentric Adapter RXMC-DD01 (Flush)	Concentric Diffuser RXRN-AED2000 & Concentric Adapter RXMC-DD01 (Drop)			
2700 [1274]	0.97	0.93	0.99	0.99	0.07 [.02]	0.32 [.08]	0.80 [.20]	0.65 [.16]	0.108 [.03]	0.070 [.02]	
2800 [1321]	0.98	0.94	0.99	0.99	0.07 [.02]	0.36 [.09]	0.85 [.21]	0.69 [.17]	0.113 [.03]	0.078 [.02]	
2900 [1368]	0.98	0.96	0.99	0.99	0.08 [.02]	0.39 [.10]	0.91 [.23]	0.74 [.18]	0.117 [.03]	0.085 [.02]	
3000 [1416]	0.99	0.97	1.00	1.00	0.08 [.02]	0.43 [.11]	0.96 [.24]	0.79 [.20]	0.122 [.03]	0.093 [.02]	
3100 [1463]	0.99	0.99	1.00	1.00	0.09 [.02]	0.47 [.12]	1.02 [.25]	0.86 [.21]	0.127 [.03]	0.100 [.02]	
3200 [1510]	1.00	1.00	1.00	1.00	0.10 [.02]	0.51 [.13]	1.08 [.27]	0.92 [.23]	0.132 [.03]	0.108 [.03]	
3300 [1557]	1.01	1.01	1.00	1.00	0.10 [.03]	0.54 [.14]	1.15 [.29]	0.99 [.25]	0.137 [.03]	0.115 [.03]	
3400 [1604]	1.01	1.03	1.01	1.01	0.11 [.03]	0.58 [.14]	1.21 [.30]	1.05 [.26]	0.142 [.03]	0.123 [.03]	
3500 [1652]	1.02	1.04	1.01	1.01	0.11 [.03]	0.62 [.15]	1.29 [.32]	1.09 [.27]	0.147 [.04]	0.131 [.03]	
3600 [1699]	1.02	1.06	1.01	1.01	0.12 [.03]	0.66 [.16]	1.36 [.34]	1.13 [.28]	0.152 [.04]	0.138 [.03]	
3700 [1746]	1.03	1.07	1.02	1.02	0.13 [.03]	0.70 [.17]	1.43 [.36]	1.18 [.29]	0.157 [.04]	0.146 [.04]	
3800 [1793]	1.03	1.09	1.02	1.02	0.13 [.03]	0.74 [.18]	1.50 [.37]	1.23 [.31]	0.162 [.04]	0.153 [.04]	
3900 [1840]	1.04	1.10	1.02	1.02	0.14 [.04]	0.77 [.19]	1.59 [.40]	1.31 [.33]	0.167 [.04]	0.161 [.04]	
4000 [1888]	1.05	1.12	1.02	1.02	0.15 [.04]	0.81 [.20]	1.68 [.42]	1.38 [.34]	0.171 [.04]	0.169 [.04]	
4100 [1935]	1.05	1.13	1.03	1.03	0.15 [.04]	0.85 [.21]	1.74 [.43]	1.44 [.36]	0.176 [.04]	0.176 [.04]	

\*Multiply correction factor times gross performance data resulting sensible capacity cannot exceed total capacity.

[ ] Designates Metric Conversions





**AIRFLOW PERFORMANCE— 10 TON [35.1 kW] — 60 Hz — DOWNFLOW (Con't.)**

Airflow	AIRFLOW CORRECTION FACTORS *				COMPONENT AIRFLOW RESISTANCE					Pressure Drop MERV 13
	CFM [L/s]	Total MBH	Sensible MBH	Power kW	Wet Coil	Vertical Economizer RA Damper Open	Concentric Diffuser RXRN-AEF3415 & Diffuser RXMC-DD02 (Flush)	Concentric Diffuser RXRN-AED3415 & Diffuser RXMC-DD02 (Drop)	Pressure Drop MERV 8	
							Resistance — Inches of Water [kPa]			
3200 [1510]	0.97	0.93	0.99	0.99	0.10 [.02]	0.07 [.02]	0.74 [.18]	0.56 [.14]	0.132 [.03]	0.108 [.03]
3300 [1557]	0.98	0.94	0.99	0.99	0.10 [.03]	0.08 [.02]	0.79 [.20]	0.59 [.15]	0.137 [.03]	0.115 [.03]
3400 [1604]	0.98	0.96	0.99	0.99	0.11 [.03]	0.09 [.02]	0.84 [.21]	0.62 [.15]	0.142 [.03]	0.123 [.03]
3500 [1652]	0.99	0.97	1.00	1.00	0.11 [.03]	0.10 [.02]	0.90 [.22]	0.66 [.16]	0.147 [.04]	0.131 [.03]
3600 [1699]	0.99	0.98	1.00	1.00	0.12 [.03]	0.11 [.03]	0.95 [.24]	0.69 [.17]	0.152 [.04]	0.138 [.03]
3700 [1746]	1.00	0.99	1.00	1.00	0.13 [.03]	0.12 [.03]	1.00 [.25]	0.73 [.18]	0.157 [.04]	0.146 [.04]
3800 [1793]	1.00	1.01	1.00	1.00	0.13 [.03]	0.13 [.03]	1.04 [.26]	0.76 [.19]	0.162 [.04]	0.153 [.04]
3900 [1840]	1.01	1.02	1.00	1.00	0.14 [.04]	0.15 [.04]	1.09 [.27]	0.80 [.20]	0.167 [.04]	0.161 [.04]
4000 [1888]	1.01	1.03	1.01	1.01	0.15 [.04]	0.16 [.04]	1.13 [.28]	0.84 [.21]	0.171 [.04]	0.169 [.04]
4100 [1935]	1.02	1.04	1.01	1.01	0.15 [.04]	0.17 [.04]	1.19 [.30]	0.88 [.22]	0.176 [.04]	0.176 [.04]
4200 [1982]	1.02	1.06	1.01	1.01	0.16 [.04]	0.19 [.05]	1.24 [.31]	0.92 [.23]	0.181 [.04]	0.184 [.05]
4300 [2029]	1.03	1.07	1.01	1.01	0.17 [.04]	0.20 [.05]	1.31 [.33]	0.97 [.24]	0.186 [.05]	0.191 [.05]
4400 [2076]	1.03	1.08	1.01	1.01	0.18 [.04]	0.21 [.05]	1.37 [.34]	1.02 [.25]	0.191 [.05]	0.199 [.05]
4500 [2123]	1.04	1.09	1.02	1.02	0.19 [.05]	0.23 [.06]	1.43 [.35]	1.07 [.27]	0.196 [.05]	0.207 [.05]
4600 [2171]	1.04	1.11	1.02	1.02	0.19 [.05]	0.24 [.06]	1.48 [.37]	1.11 [.28]	0.201 [.05]	0.214 [.05]
4700 [2218]	1.05	1.12	1.02	1.02	0.20 [.05]	0.26 [.06]	1.54 [.38]	1.15 [.29]	0.206 [.05]	0.222 [.05]
4800 [2265]	1.05	1.13	1.02	1.02	0.21 [.05]	0.28 [.07]	1.59 [.40]	1.19 [.30]	0.211 [.05]	0.229 [.06]

\*Multiply correction factor times gross performance data resulting sensible capacity cannot exceed total capacity.

[ ] Designates Metric Conversions



**AIRFLOW PERFORMANCE— 10 TON [35.1 kW] — 60 Hz — SIDEFLOW (Con't.)**

Airflow	AIRFLOW CORRECTION FACTORS *				COMPONENT AIRFLOW RESISTANCE					Pressure Drop MERV 13
	CFM [L/s]	Total MBH	Sensible MBH	Power kW	Wet Coil	Horizontal Economizer RA Damper Open	Resistance — Inches of Water [kPa]		Pressure Drop MERV 8	
							Concentric Diffuser RXRN-AEF3415 & Diffuser RXMC-DD02 (Flush)	Concentric Diffuser RXRN-AED3415 & Diffuser RXMC-DD02 (Drop)		
3200 [1510]	0.97	0.93	0.99	0.10 [0.02]	0.51 [0.13]	0.74 [0.18]	0.56 [0.14]	0.132 [0.03]	0.108 [0.03]	
3300 [1557]	0.98	0.94	0.99	0.10 [0.03]	0.54 [0.14]	0.79 [0.20]	0.59 [0.15]	0.137 [0.03]	0.115 [0.03]	
3400 [1604]	0.98	0.96	0.99	0.11 [0.03]	0.58 [0.14]	0.84 [0.21]	0.62 [0.15]	0.142 [0.03]	0.123 [0.03]	
3500 [1652]	0.99	0.97	1.00	0.11 [0.03]	0.62 [0.15]	0.90 [0.22]	0.66 [0.16]	0.147 [0.04]	0.131 [0.03]	
3600 [1699]	0.99	0.98	1.00	0.12 [0.03]	0.66 [0.16]	0.95 [0.24]	0.69 [0.17]	0.152 [0.04]	0.138 [0.03]	
3700 [1746]	1.00	0.99	1.00	0.13 [0.03]	0.70 [0.17]	1.00 [0.25]	0.73 [0.18]	0.157 [0.04]	0.146 [0.04]	
3800 [1793]	1.00	1.01	1.00	0.13 [0.03]	0.74 [0.18]	1.04 [0.26]	0.76 [0.19]	0.162 [0.04]	0.153 [0.04]	
3900 [1840]	1.01	1.02	1.00	0.14 [0.04]	0.77 [0.19]	1.09 [0.27]	0.80 [0.20]	0.167 [0.04]	0.161 [0.04]	
4000 [1888]	1.01	1.03	1.01	0.15 [0.04]	0.81 [0.20]	1.13 [0.28]	0.84 [0.21]	0.171 [0.04]	0.169 [0.04]	
4100 [1935]	1.02	1.04	1.01	0.15 [0.04]	0.85 [0.21]	1.19 [0.30]	0.88 [0.22]	0.176 [0.04]	0.176 [0.04]	
4200 [1982]	1.02	1.06	1.01	0.16 [0.04]	0.89 [0.22]	1.24 [0.31]	0.92 [0.23]	0.181 [0.04]	0.184 [0.05]	
4300 [2029]	1.03	1.07	1.01	0.17 [0.04]	0.93 [0.23]	1.31 [0.33]	0.97 [0.24]	0.186 [0.05]	0.191 [0.05]	
4400 [2076]	1.03	1.08	1.01	0.18 [0.04]	0.97 [0.24]	1.37 [0.34]	1.02 [0.25]	0.191 [0.05]	0.199 [0.05]	
4500 [2123]	1.04	1.09	1.02	0.19 [0.05]	1.01 [0.25]	1.43 [0.35]	1.07 [0.27]	0.196 [0.05]	0.207 [0.05]	
4600 [2171]	1.04	1.11	1.02	0.19 [0.05]	1.06 [0.26]	1.48 [0.37]	1.11 [0.28]	0.201 [0.05]	0.214 [0.05]	
4700 [2218]	1.05	1.12	1.02	0.20 [0.05]	1.10 [0.27]	1.54 [0.38]	1.15 [0.29]	0.206 [0.05]	0.222 [0.05]	
4800 [2265]	1.05	1.13	1.02	0.21 [0.05]	1.14 [0.28]	1.59 [0.40]	1.19 [0.30]	0.211 [0.05]	0.229 [0.06]	

\*Multiply correction factor times gross performance data resulting sensible capacity cannot exceed total capacity.

[ ] Designates Metric Conversions

# AIRFLOW PERFORMANCE— 12.5 TON [43.9 kW] — 60 Hz — DOWNFLOW

Air Flow CFM [L/s]	Model RACDZ*150* Voltage 208/230, 460, 575 — 3 phase 60 Hz																							
	External Static Pressure—Inches of Water [kPa]																							
	0.1 [0.2]	0.2 [0.05]	0.3 [0.07]	0.4 [0.10]	0.5 [0.12]	0.6 [0.15]	0.7 [0.17]	0.8 [0.20]	0.9 [0.22]	1.0 [0.25]	1.1 [0.27]	1.2 [0.30]	1.3 [0.32]	1.4 [0.35]	1.5 [0.37]	1.6 [0.40]	1.7 [0.42]	1.8 [0.45]	1.9 [0.47]	2.0 [0.50]				
4000 [1888]	766 [1776]	795 [1806]	824 [1842]	851 [1883]	878 [1931]	904 [1985]	929 [2044]	953 [2110]	976 [2181]	998 [2259]	1019 [2342]	1040 [2431]	1059 [2526]	1078 [2627]	1096 [2734]	1113 [2847]	1129 [2966]	1144 [3091]	1158 [3221]	1171 [3358]				
4100 [1935]	778 [1820]	807 [1856]	835 [1897]	862 [1944]	888 [1997]	913 [2056]	937 [2120]	961 [2191]	983 [2268]	1005 [2350]	1026 [2439]	1045 [2533]	1064 [2634]	1082 [2740]	1099 [2852]	1116 [2970]	1131 [3094]	1145 [3224]	1159 [3360]	1171 [3502]				
4200 [1982]	792 [1875]	820 [1915]	847 [1961]	873 [2014]	899 [2072]	923 [2136]	947 [2206]	969 [2282]	991 [2364]	1012 [2451]	1032 [2545]	1051 [2645]	1070 [2750]	1087 [2862]	1103 [2979]	1119 [3102]	1134 [3232]	1147 [3367]	1160 [3508]	1172 [3655]				
4300 [2029]	806 [1938]	833 [1984]	859 [2036]	885 [2093]	910 [2156]	934 [2226]	957 [2301]	979 [2382]	1000 [2469]	1020 [2562]	1040 [2661]	1058 [2766]	1076 [2877]	1092 [2993]	1108 [3116]	1123 [3244]	1137 [3379]	1150 [3519]	1162 [3665]	1174 [3818]				
4400 [2076]	820 [2012]	847 [2063]	873 [2119]	898 [2182]	922 [2251]	945 [2325]	967 [2406]	989 [2492]	1009 [2584]	1029 [2682]	1048 [2787]	1065 [2897]	1082 [3013]	1098 [3134]	1113 [3262]	1128 [3396]	1141 [3536]	1154 [3681]	1165 [3833]	1176 [3990]				
4500 [2123]	835 [2095]	861 [2151]	886 [2213]	911 [2281]	934 [2355]	957 [2434]	978 [2520]	999 [2611]	1019 [2709]	1038 [2812]	1056 [2922]	1073 [3037]	1090 [3158]	1105 [3285]	1119 [3418]	1133 [3557]	1146 [3702]	1158 [3853]	1168 [4009]	1178 [4172]				
4600 [2171]	851 [2187]	876 [2249]	901 [2316]	925 [2389]	947 [2468]	969 [2553]	990 [2644]	1010 [2740]	1030 [2843]	1048 [2952]	1065 [3066]	1082 [3187]	1097 [3313]	1112 [3445]	1126 [3584]	1139 [3728]	1151 [3878]	1162 [4034]	1172 [4196]	1182 [4363]				
4800 [2265]	884 [2401]	908 [2473]	932 [2551]	954 [2634]	975 [2723]	996 [2819]	1016 [2920]	1034 [3027]	1052 [3140]	1069 [3259]	1085 [3384]	1101 [3515]	1115 [3652]	1128 [3795]	1141 [3943]	1153 [4098]	1163 [4258]	1173 [4425]	1182 [4597]	1190 [4775]				
4900 [2312]	902 [2523]	925 [2599]	948 [2682]	969 [2771]	990 [2866]	1010 [2966]	1029 [3073]	1047 [3185]	1065 [3303]	1081 [3427]	1097 [3558]	1111 [3694]	1125 [3836]	1138 [3984]	1149 [4137]	1160 [4297]	1170 [4463]	1180 [4634]	1188 [4812]	1195 [4995]				
5000 [2359]	920 [2653]	943 [2736]	965 [2824]	986 [2917]	1006 [3017]	1025 [3123]	1044 [3235]	1061 [3352]	1078 [3476]	1093 [3605]	1108 [3741]	1122 [3882]	1135 [4029]	1147 [4182]	1158 [4341]	1169 [4506]	1178 [4677]	1187 [4854]	1194 [5036]	1201 [5225]				
5200 [2454]	958 [2944]	980 [3036]	1000 [3135]	1020 [3239]	1039 [3349]	1057 [3465]	1074 [3588]	1090 [3716]	1105 [3849]	1120 [3989]	1133 [4135]	1146 [4287]	1158 [4444]	1168 [4608]	1178 [4777]	1187 [4953]	1196 [5134]	1203 [5321]	1209 [5514]	1215 [5713]				
5300 [2501]	978 [3103]	999 [3201]	1019 [3305]	1038 [3414]	1056 [3530]	1074 [3651]	1090 [3778]	1106 [3912]	1120 [4051]	1134 [4196]	1147 [4347]	1159 [4504]	1170 [4666]	1180 [4835]	1189 [5010]	1198 [5190]	1205 [5377]	1212 [5569]	1217 [5767]	1222 [5972]				
5400 [2548]	999 [3273]	1019 [3376]	1038 [3484]	1057 [3599]	1074 [3720]	1091 [3846]	1107 [3979]	1122 [4117]	1136 [4261]	1149 [4412]	1161 [4568]	1172 [4730]	1183 [4898]	1192 [5072]	1201 [5252]	1209 [5438]	1215 [5629]	1221 [5827]	1226 [6030]	—				
5500 [2595]	1020 [3451]	1040 [3559]	1058 [3673]	1076 [3793]	1093 [3919]	1109 [4051]	1124 [4189]	1138 [4332]	1152 [4482]	1164 [4637]	1176 [4799]	1186 [4966]	1196 [5139]	1205 [5318]	1213 [5503]	1220 [5694]	1226 [5891]	—	—	—				
5600 [2643]	1042 [3640]	1061 [3753]	1079 [3872]	1096 [3997]	1112 [4128]	1128 [4265]	1142 [4408]	1156 [4557]	1168 [4712]	1180 [4872]	1191 [5039]	1201 [5212]	1210 [5390]	1218 [5574]	1226 [5765]	—	—	—	—	—				
5700 [2690]	1064 [3838]	1083 [3956]	1100 [4080]	1117 [4211]	1132 [4347]	1147 [4489]	1161 [4637]	1174 [4791]	1186 [4951]	1197 [5117]	1207 [5289]	1216 [5467]	1225 [5650]	—	—	—	—	—	—	—				
5800 [2737]	1088 [4045]	1105 [4169]	1122 [4298]	1138 [4434]	1153 [4575]	1167 [4723]	1180 [4876]	1192 [5035]	1204 [5200]	1214 [5371]	1224 [5548]	—	—	—	—	—	—	—	—	—				
5900 [2784]	1111 [4262]	1128 [4391]	1144 [4526]	1160 [4666]	1174 [4813]	1187 [4966]	1200 [5124]	1211 [5289]	1222 [5459]	—	—	—	—	—	—	—	—	—	—	—				
6000 [2831]	1136 [4489]	1152 [4623]	1167 [4763]	1182 [4909]	1196 [5061]	1210 [5218]	1220 [5382]	—	—	—	—	—	—	—	—	—	—	—	—	—				

NOTE: A/F—Drive left of the bold line, B/G—Drive right of bold lines.

Drive Package	A/F										B/G													
Motor H.P. [W]	3 [2237.1]					<b>5 [3728.5]</b>					—					—								
Blower Sheave	AK71H					AK79H					—					—								
Motor Sheave	1VL44*7/8					1VP60*1x1/8					—					—								
Belt	A48					A52					—					—								
Turns Open	0	1	2	3	4	5	0	1	2	3	4	5	0	1	2	3	4	5	0	1	2	3	4	5
RPM	1003	958	<b>912</b>	863	814	764	1220	1171	1127	1085	1039	994	—	—	—	—	—	—	—	—	—	—	—	—

- NOTES: 1. Factory sheave settings are shown in bold type.  
 2. Do not set motor sheave below minimum or maximum turns open shown.  
 3. Re-adjustment of sheave required to achieve rated airflow at AHRI minimum External Static Pressure  
 4. Add component resistance (below) to duct resistance to determine total External Static Pressure.

[ ] Designates Metric Conversions

**AIRFLOW PERFORMANCE— 12.5 TON [43.9 kW] — 60 Hz — DOWNFLOW (Con't.)**

Airflow		AIRFLOW CORRECTION FACTORS *			COMPONENT AIRFLOW RESISTANCE				Pressure Drop MERV 8	Pressure Drop MERV 13
		Total MBH	Sensible MBH	Power kW	Wet Coil	Vertical Economizer RA Damper Open	Concentric Diffuser RXRN-AEF3618 & Concentric Adapter RXMC-DD03 (Flush)	Concentric Diffuser RXRN-AED3618 & Concentric Adapter RXMC-DD03 (Drop)		
4000 [1888]	1.01	1.03	1.01	0.15 [0.04]	0.16 [0.04]	0.76 [0.19]	0.68 [0.17]	0.132 [0.03]	0.108 [0.03]	
4100 [1935]	1.02	1.04	1.01	0.16 [0.04]	0.17 [0.04]	0.79 [0.20]	0.72 [0.18]	0.136 [0.03]	0.114 [0.03]	
4200 [1982]	1.02	1.06	1.01	0.17 [0.04]	0.19 [0.05]	0.82 [0.20]	0.75 [0.19]	0.140 [0.03]	0.120 [0.03]	
4300 [2029]	1.03	1.07	1.01	0.17 [0.04]	0.20 [0.05]	0.86 [0.21]	0.79 [0.20]	0.144 [0.03]	0.126 [0.03]	
4400 [2076]	1.03	1.08	1.01	0.18 [0.05]	0.21 [0.05]	0.90 [0.22]	0.83 [0.21]	0.148 [0.04]	0.132 [0.03]	
4500 [2123]	1.04	1.09	1.02	0.19 [0.05]	0.23 [0.06]	0.94 [0.23]	0.86 [0.21]	0.152 [0.04]	0.138 [0.03]	
4600 [2171]	1.04	1.11	1.02	0.20 [0.05]	0.24 [0.06]	0.98 [0.24]	0.89 [0.22]	0.156 [0.04]	0.145 [0.04]	
4700 [2218]	1.05	1.12	1.02	0.21 [0.05]	0.26 [0.06]	1.02 [0.25]	0.94 [0.23]	0.160 [0.04]	0.151 [0.04]	
4800 [2265]	1.05	1.13	1.02	0.21 [0.05]	0.28 [0.07]	1.06 [0.26]	0.98 [0.24]	0.164 [0.04]	0.157 [0.04]	
4900 [2312]	1.06	1.14	1.02	0.22 [0.06]	0.29 [0.07]	1.10 [0.27]	1.01 [0.25]	0.168 [0.04]	0.163 [0.04]	
5000 [2359]	1.06	1.16	1.03	0.23 [0.06]	0.31 [0.08]	1.14 [0.28]	1.04 [0.26]	0.172 [0.04]	0.169 [0.04]	
5100 [2407]	1.07	1.17	1.03	0.24 [0.06]	0.33 [0.08]	1.18 [0.29]	1.07 [0.27]	0.176 [0.04]	0.175 [0.04]	
5200 [2454]	1.07	1.18	1.03	0.25 [0.06]	0.35 [0.09]	1.22 [0.30]	1.10 [0.27]	0.180 [0.04]	0.182 [0.04]	
5300 [2501]	1.08	1.19	1.03	0.26 [0.06]	0.36 [0.09]	1.27 [0.32]	1.15 [0.29]	0.184 [0.05]	0.188 [0.05]	
5400 [2548]	1.08	1.21	1.03	0.27 [0.07]	0.38 [0.09]	1.33 [0.33]	1.20 [0.30]	0.188 [0.05]	0.194 [0.05]	
5500 [2595]	1.09	1.22	1.04	0.28 [0.07]	0.40 [0.10]	1.37 [0.34]	1.25 [0.31]	0.192 [0.05]	0.200 [0.05]	
5600 [2643]	1.09	1.23	1.04	0.29 [0.07]	0.42 [0.10]	1.42 [0.35]	1.30 [0.32]	0.196 [0.05]	0.206 [0.05]	
5700 [2690]	1.10	1.24	1.04	0.30 [0.07]	0.44 [0.11]	1.47 [0.37]	1.34 [0.33]	0.200 [0.05]	0.212 [0.05]	
5800 [2737]	1.10	1.26	1.04	0.31 [0.08]	0.46 [0.11]	1.52 [0.38]	1.38 [0.34]	0.204 [0.05]	0.219 [0.05]	
5900 [2784]	1.10	1.27	1.05	0.32 [0.08]	0.48 [0.12]	1.56 [0.39]	1.42 [0.35]	0.208 [0.05]	0.225 [0.05]	
6000 [2831]	1.11	1.28	1.05	0.33 [0.08]	0.51 [0.13]	1.60 [0.40]	1.45 [0.36]	0.212 [0.05]	0.231 [0.06]	

\*Multiply correction factor times gross performance data resulting sensible capacity cannot exceed total capacity.

[ ] Designates Metric Conversions





**AIRFLOW PERFORMANCE— 12.5 TON [43.9 kW] — 60 Hz — SIDEFLOW (Con't.)**

Airflow	AIRFLOW CORRECTION FACTORS *				COMPONENT AIRFLOW RESISTANCE					Pressure Drop MERV 13
	CFM [L/s]	Total MBH	Sensible MBH	Power kW	Wet Coil	Horizontal Economizer RA Damper Open	Resistance — Inches of Water		Concentric Diffuser MERV 8	
							Concentric Diffuser RXRN-AEF3618 & Concentric Adapter RXMC-DD03 (Flush)	Concentric Diffuser RXRN-AED3618 & Concentric Adapter RXMC-DD03 (Drop)		
4000 [1888]	1.01	1.03	1.03	1.01	0.15 [04]	0.73 [18]	0.76 [19]	0.68 [17]	0.132 [03]	0.108 [03]
4100 [1935]	1.02	1.04	1.04	1.01	0.16 [04]	0.78 [19]	0.79 [20]	0.72 [18]	0.136 [03]	0.114 [03]
4200 [1982]	1.02	1.06	1.06	1.01	0.17 [04]	0.83 [21]	0.82 [20]	0.75 [19]	0.140 [03]	0.120 [03]
4300 [2029]	1.03	1.07	1.07	1.01	0.17 [04]	0.88 [22]	0.86 [21]	0.79 [20]	0.144 [03]	0.126 [03]
4400 [2076]	1.03	1.08	1.08	1.01	0.18 [05]	0.93 [23]	0.90 [22]	0.83 [21]	0.148 [04]	0.132 [03]
4500 [2123]	1.04	1.09	1.09	1.02	0.19 [05]	0.98 [24]	0.94 [23]	0.86 [21]	0.152 [04]	0.138 [03]
4600 [2171]	1.04	1.11	1.11	1.02	0.20 [05]	1.03 [26]	0.98 [24]	0.89 [22]	0.156 [04]	0.145 [04]
4700 [2218]	1.05	1.12	1.12	1.02	0.21 [05]	1.07 [27]	1.02 [25]	0.94 [23]	0.160 [04]	0.151 [04]
4800 [2265]	1.05	1.13	1.13	1.02	0.21 [05]	1.12 [28]	1.06 [26]	0.98 [24]	0.164 [04]	0.157 [04]
4900 [2312]	1.06	1.14	1.14	1.02	0.22 [06]	1.17 [29]	1.10 [27]	1.01 [25]	0.168 [04]	0.163 [04]
5000 [2359]	1.06	1.16	1.16	1.03	0.23 [06]	1.21 [30]	1.14 [28]	1.04 [26]	0.172 [04]	0.169 [04]
5100 [2407]	1.07	1.17	1.17	1.03	0.24 [06]	1.26 [31]	1.18 [29]	1.07 [27]	0.176 [04]	0.175 [04]
5200 [2454]	1.07	1.18	1.18	1.03	0.25 [06]	1.30 [32]	1.22 [30]	1.10 [27]	0.180 [04]	0.182 [04]
5300 [2501]	1.08	1.19	1.19	1.03	0.26 [06]	1.35 [34]	1.27 [32]	1.15 [29]	0.184 [05]	0.188 [05]
5400 [2548]	1.08	1.21	1.21	1.03	0.27 [07]	1.39 [35]	1.33 [33]	1.20 [30]	0.188 [05]	0.194 [05]
5500 [2595]	1.09	1.22	1.22	1.04	0.28 [07]	1.44 [36]	1.37 [34]	1.25 [31]	0.192 [05]	0.200 [05]
5600 [2643]	1.09	1.23	1.23	1.04	0.29 [07]	1.48 [37]	1.42 [35]	1.30 [32]	0.196 [05]	0.206 [05]
5700 [2690]	1.10	1.24	1.24	1.04	0.30 [07]	1.52 [38]	1.47 [37]	1.34 [33]	0.200 [05]	0.212 [05]
5800 [2737]	1.10	1.26	1.26	1.04	0.31 [08]	1.57 [39]	1.52 [38]	1.38 [34]	0.204 [05]	0.219 [05]
5900 [2784]	1.10	1.27	1.27	1.05	0.32 [08]	1.61 [40]	1.56 [39]	1.42 [35]	0.208 [05]	0.225 [05]
6000 [2831]	1.11	1.28	1.28	1.05	0.33 [08]	1.65 [41]	1.60 [40]	1.45 [36]	0.212 [05]	0.231 [06]

\*Multiply correction factor times gross performance data resulting sensible capacity cannot exceed total capacity.

[ ] Designates Metric Conversions



<b>ELECTRICAL DATA – RACDZT SERIES</b>							
		<b>090ACF</b>	<b>090ACG 090ACH</b>	<b>090ADF</b>	<b>090ADG 090ADH</b>	<b>090AYF</b>	<b>090AYG 090AYH</b>
<b>Unit Information</b>	Unit Operating Voltage Range	187-253	187-253	414-506	414-506	517-633	517-633
	Volts	208/230	208/230	460	460	575	575
	Phase	3	3	3	3	3	3
	Hz	60	60	60	60	60	60
	Minimum Circuit Ampacity	41	44	17	19	15	16
	Minimum Overcurrent Protection Device Size	50	50	20	25	20	20
<b>Compressor Motor</b>	Maximum Overcurrent Protection Device Size	60	60	25	25	20	20
	No.	1	1	1	1	1	1
	Volts	208/230	208/230	460	460	575	575
	Phase	3	3	3	3	3	3
	RPM	3500	3500	3500	3500	3500	3500
	HP, Compressor 1	7	7	7	7	7	7
<b>Condenser Motor</b>	Amps (RLA), Comp. 1	25.3	25.3	9.6	9.6	8.4	8.4
	Amps (LRA), Comp. 1	184	184	84	84	60	60
	No.	2	2	2	2	2	2
	Volts	208/230	208/230	460	460	575	575
	Phase	1	1	1	1	1	1
	HP	1/5	1/5	1/5	1/5	1/5	1/5
<b>Evaporator Fan</b>	Amps (FLA, each)	1.2	1.2	0.8	0.8	0.6	0.6
	Amps (LRA, each)	2.3	2.3	1.4	1.4	1.0	1.0
	No.	1	1	1	1	1	1
	Volts	208/230	208/230	460	460	575	575
	Phase	3	3	3	3	3	3
	HP	2	3	2	3	2	3
<b>Evaporator Fan</b>	Amps (FLA, each)	6.6	9.1	3.2	4.6	2.5	3.5
	Amps (LRA, each)	47.0	74.5	24.0	38.1	19.0	30.0

**ELECTRICAL DATA – RACDZT SERIES**

		<b>102ACF</b>	<b>102ACG</b>	<b>102ACH</b>	<b>102ADF</b>
<b>Unit Information</b>	Unit Operating Voltage Range	187-253	187-253	187-253	414-506
	Volts	208/230	208/230	208/230	460
	Phase	3	3	3	3
	Hz	60	60	60	60
	Minimum Circuit Ampacity	46	48	51	21
	Minimum Overcurrent Protection Device Size	60	60	60	25
	Maximum Overcurrent Protection Device Size	70	70	70	30
<b>Compressor Motor</b>	No.	1	1	1	1
	Volts	208/230	208/230	208/230	460
	Phase	3	3	3	3
	RPM	3500	3500	3500	3500
	HP, Compressor 1	7 1/2	7 1/2	7 1/2	7 1/2
	Amps (RLA), Comp. 1	28.8	28.8	28.8	12.5
	Amps (LRA), Comp. 1	223	223	223	100
<b>Condenser Motor</b>	No.	2	2	2	2
	Volts	208/230	208/230	208/230	460
	Phase	1	1	1	1
	HP	1/5	1/5	1/5	1/5
	Amps (FLA, each)	1.2	1.2	1.2	0.8
	Amps (LRA, each)	2.3	2.3	2.3	1.4
<b>Evaporator Fan</b>	No.	1	1	1	1
	Volts	208/230	208/230	208/230	460
	Phase	3	3	3	3
	HP	2	3	3	2
	Amps (FLA, each)	7	9.1	12	3.5
	Amps (LRA, each)	47.0	74.5	74.5	24.0

<b>ELECTRICAL DATA – RACDZT SERIES</b>					
		<b>102ADG</b>	<b>102ADH</b>	<b>102AYF</b>	<b>102AYG 102AYH</b>
<b>Unit Information</b>	Unit Operating Voltage Range	414-506	414-506	517-633	517-633
	Volts	460	460	575	575
	Phase	3	3	3	3
	Hz	60	60	60	60
	Minimum Circuit Ampacity	22	24	16	17
	Minimum Overcurrent Protection Device Size	25	30	20	20
	Maximum Overcurrent Protection Device Size	30	35	25	25
<b>Compressor Motor</b>	No.	1	1	1	1
	Volts	460	460	575	575
	Phase	3	3	3	3
	RPM	3500	3500	3500	3500
	HP, Compressor 1	7 1/2	7 1/2	7 1/2	7 1/2
	Amps (RLA), Comp. 1	12.5	12.5	9.7	9.7
	Amps (LRA), Comp. 1	100	100	70	70
<b>Condenser Motor</b>	No.	2	2	2	2
	Volts	460	460	575	575
	Phase	1	1	1	1
	HP	1/5	1/5	1/5	1/5
	Amps (FLA, each)	0.8	0.8	0.6	0.6
	Amps (LRA, each)	1.4	1.4	1.0	1.0
<b>Evaporator Fan</b>	No.	1	1	1	1
	Volts	460	460	575	575
	Phase	3	3	3	3
	HP	3	3	2	3
	Amps (FLA, each)	4.6	6.0	2.5	3.5
	Amps (LRA, each)	38.1	38.1	19	30

**ELECTRICAL DATA – RACDZT SERIES**

		<b>120ACF</b>	<b>120ACG</b>	<b>120ACH</b>	<b>120ADF</b>
<b>Unit Information</b>	Unit Operating Voltage Range	187-253	187-253	187-253	414-506
	Volts	208/230	208/230	208/230	460
	Phase	3	3	3	3
	Hz	60	60	60	60
	Minimum Circuit Ampacity	54	56	58	26
	Minimum Overcurrent Protection Device Size	70	70	70	30
	Maximum Overcurrent Protection Device Size	80	80	90	40
<b>Compressor Motor</b>	No.	1	1	1	1
	Volts	208/230	208/230	208/230	460
	Phase	3	3	3	3
	RPM	3500	3500	3500	3500
	HP, Compressor 1	10	10	10	10
	Amps (RLA), Comp. 1	32.6	32.6	32.6	14.8
	Amps (LRA), Comp. 1	240	240	240	130
<b>Condenser Motor</b>	No.	2	2	2	2
	Volts	208/230	208/230	208/230	460
	Phase	1	1	1	1
	HP	1/3	1/3	1/3	1/3
	Amps (FLA, each)	2.4	2.4	2.4	1.4
	Amps (LRA, each)	4.7	4.7	4.7	2.4
<b>Evaporator Fan</b>	No.	1	1	1	1
	Volts	208/230	208/230	208/230	460
	Phase	3	3	3	3
	HP	2	3	3	2
	Amps (FLA, each)	7.9	10.1	12	3.9
	Amps (LRA, each)	47.0	74.5	74.5	24.0

<b>ELECTRICAL DATA – RACDZT SERIES</b>					
		<b>120ADG</b>	<b>120ADH</b>	<b>120AYF</b>	<b>120AYG 120AYH</b>
<b>Unit Information</b>	Unit Operating Voltage Range	414-506	414-506	517-633	517-633
	Volts	460	460	575	575
	Phase	3	3	3	3
	Hz	60	60	60	60
	Minimum Circuit Ampacity	27	28	19	20
	Minimum Overcurrent Protection Device Size	35	35	25	25
<b>Compressor Motor</b>	Maximum Overcurrent Protection Device Size	40	40	25	30
	No.	1	1	1	1
	Volts	460	460	575	575
	Phase	3	3	3	3
	RPM	3500	3500	3500	3500
	HP, Compressor 1	10	10	10	10
	Amps (RLA), Comp. 1	14.8	14.8	11.1	11.1
<b>Condenser Motor</b>	Amps (LRA), Comp. 1	130	130	93.7	93.7
	No.	2	2	2	2
	Volts	460	460	575	575
	Phase	1	1	1	1
	HP	1/3	1/3	1/3	1/3
	Amps (FLA, each)	1.4	1.4	1.0	1.0
<b>Evaporator Fan</b>	Amps (LRA, each)	2.4	2.4	4.7	4.7
	No.	1	1	1	1
	Volts	460	460	575	575
	Phase	3	3	3	3
	HP	3	3	2	3
	Amps (FLA, each)	5.1	6.0	2.5	3.5
Amps (LRA, each)	38.1	38.1	19	30	

**ELECTRICAL DATA – RACDZT SERIES**

		150ACF	150ACG	150ADF	150ADG	150AYF	150AYG
<b>Unit Information</b>	Unit Operating Voltage Range	187-253	187-253	414-506	414-506	517-633	517-633
	Volts	208/230	208/230	460	460	575	575
	Phase	3	3	3	3	3	3
	Hz	60	60	60	60	60	60
	Minimum Circuit Ampacity	70	75	34	37	25	27
	Minimum Overcurrent Protection Device Size	80	90	40	40	30	30
	Maximum Overcurrent Protection Device Size	90	90	40	45	30	30
<b>Compressor Motor</b>	No.	2	2	2	2	1	1
	Volts	208/230	208/230	460	460	575	575
	Phase	3	3	3	3	3	3
	RPM	3500	3500	3500	3500	3500	3500
	HP, Compressor 1	6	6	6	6	6	6
	Amps (RLA), Comp. 1	22.4	22.4	10.6	10.6	7.7	7.7
	Amps (LRA), Comp. 1	149	149	75	75	54	54
	HP, Compressor 2	6	6	6	6	6	6
	Amps (RLA), Comp. 2	22.4	22.4	10.6	10.6	7.7	7.7
	Amps (LRA), Comp. 2	149	149	75	75	54	54
<b>Condenser Motor</b>	No.	2	2	2	2	2	2
	Volts	208/230	208/230	460	460	575	575
	Phase	1	1	1	1	1	1
	HP	3/4	3/4	3/4	3/4	3/4	3/4
	Amps (FLA, each)	4.2	4.2	2.3	2.3	1.6	1.6
	Amps (LRA, each)	10.1	10.1	4.9	4.9	3.4	3.4
<b>Evaporator Fan</b>	No.	1	1	1	1	1	1
	Volts	208/230	208/230	460	460	575	575
	Phase	3	3	3	3	3	3
	HP	3	5	3	5	3	5
	Amps (FLA, each)	10.4	16	5.2	8	4.4	5.9
	Amps (LRA, each)	74.5	95	38.1	47.5	30	38



**208/240 VOLT, THREE PHASE, 60 Hz, AUXILIARY ELECTRIC HEATER KITS CHARACTERISTICS AND APPLICATION**

Single Power Supply For Both Unit and Heater Kit										Separate Power Supply For Both Unit and Heater Kit									
Unit Model No.	RXJJ-Heater Kit Nominal kW	No. of Sequence Steps	Heater Kit			Air Conditioner				Heater Kit			Air Conditioner						
			Rated Heater kW @ 208/240 V	Heater KBTU/Hr @ 208/240 V	Heater Amp. @ 208/240 V	Unit Min. Ampacity @ 208/240 V	Over Current Protective Device Size Min./Max. @ 208 V	Over Current Protective Device Size Min./Max. @ 240 V	Min. Ckt. Ampacity 208/240 V	Max. Fuse Size 208/240 V	Min. Circuit Ampacity 208/240 V	Over Current Protective Device Size Min./Max. @ 208 V	Over Current Protective Device Size Min./Max. @ 240 V						
RACDZT 090ACF	No Heat	—	—	—	—	41/41	50/60	50/60	—	—	41/41	50/60	50/60	41/41	50/60	50/60			
	DD10CP	7.4/9.9	25.25/33.77	20.6/23.8	41/41	50/60	50/60	26/30	30/30	41/41	50/60	50/60	41/41	50/60	50/60	50/60			
	DD15CP	10.8/14.4	36.84/49.13	30.0/34.6	46/52	60/60	60/60	38/44	40/45	41/41	50/60	50/60	41/41	50/60	50/60	50/60			
	DD20CP	14.9/19.8	50.83/67.55	41.3/47.6	60/68	70/70	70/70	52/60	60/90	41/41	50/60	50/60	41/41	50/60	50/60	50/60			
	DD30CP	21.6/28.8	73.69/98.25	60.0/69.3	84/95	90/90	100/100	75/87	80/90	41/41	50/60	50/60	41/41	50/60	50/60	50/60			
	DD40CP	29.7/39.6	101.32/135.10	82.5/95.2	112/128	125/125	150/150	104/119	110/125	41/41	50/60	50/60	41/41	50/60	50/60	50/60			
RACDZT 090ACG	No Heat	—	—	—	—	44/44	50/60	50/60	—	—	44/44	50/60	50/60	44/44	50/60	50/60			
	DD10CP	7.4/9.9	25.25/33.77	20.6/23.8	44/44	50/60	50/60	26/30	30/30	44/44	50/60	50/60	44/44	50/60	50/60	50/60			
	DD15CP	10.8/14.4	36.84/49.13	30.0/34.6	49/55	60/60	60/60	38/44	40/45	44/44	50/60	50/60	44/44	50/60	50/60	50/60			
	DD20CP	14.9/19.8	50.83/67.55	41.3/47.6	63/71	70/70	80/80	52/60	60/90	44/44	50/60	50/60	44/44	50/60	50/60	50/60			
	DD30CP	21.6/28.8	73.69/98.25	60.0/69.3	87/98	90/90	100/100	75/87	80/90	44/44	50/60	50/60	44/44	50/60	50/60	50/60			
	DD40CP	29.7/39.6	101.32/135.10	82.5/95.2	115/131	125/125	150/150	104/119	110/125	44/44	50/60	50/60	44/44	50/60	50/60	50/60			
RACDZT 102ACF	No Heat	—	—	—	—	46/46	60/70	60/70	—	—	46/46	60/70	60/70	46/46	60/70	60/70			
	DD10CP	7.4/9.9	25.25/33.77	20.6/23.8	46/46	60/70	60/70	26/30	30/30	46/46	60/70	60/70	46/46	60/70	60/70	60/70			
	DD15CP	10.8/14.4	36.84/49.13	30.0/34.6	47/52	60/70	60/70	38/44	40/45	46/46	60/70	60/70	46/46	60/70	60/70	60/70			
	DD20CP	14.9/19.8	50.83/67.55	41.3/47.6	61/69	70/70	70/70	52/60	60/90	46/46	60/70	60/70	46/46	60/70	60/70	60/70			
	DD30CP	21.6/28.8	73.69/98.25	60.0/69.3	84/96	90/90	100/100	75/87	80/90	46/46	60/70	60/70	46/46	60/70	60/70	60/70			
	DD40CP	29.7/39.6	101.32/135.10	82.5/95.2	112/128	125/125	150/150	104/119	110/125	46/46	60/70	60/70	46/46	60/70	60/70	60/70			
RACDZT 102ACG	No Heat	—	—	—	—	48/48	60/70	60/70	—	—	48/48	60/70	60/70	48/48	60/70	60/70			
	DD10CP	7.4/9.9	25.25/33.77	20.6/23.8	48/48	60/70	60/70	26/30	30/30	48/48	60/70	60/70	48/48	60/70	60/70	60/70			
	DD15CP	10.8/14.4	36.84/49.13	30.0/34.6	49/55	60/70	60/70	38/44	40/45	48/48	60/70	60/70	48/48	60/70	60/70	60/70			
	DD20CP	14.9/19.8	50.83/67.55	41.3/47.6	63/71	70/70	80/80	52/60	60/90	48/48	60/70	60/70	48/48	60/70	60/70	60/70			
	DD30CP	21.6/28.8	73.69/98.25	60.0/69.3	87/98	90/90	100/100	75/87	80/90	48/48	60/70	60/70	48/48	60/70	60/70	60/70			
	DD40CP	29.7/39.6	101.32/135.10	82.5/95.2	115/131	125/125	150/150	104/119	110/125	48/48	60/70	60/70	48/48	60/70	60/70	60/70			
RACDZT 102ACH	No Heat	—	—	—	—	51/51	60/70	60/70	—	—	51/51	60/70	60/70	51/51	60/70	60/70			
	DD10CP	7.4/9.9	25.25/33.77	20.6/23.8	51/51	60/70	60/70	26/30	30/30	51/51	60/70	60/70	51/51	60/70	60/70	60/70			
	DD15CP	10.8/14.4	36.84/49.13	30.0/34.6	53/59	60/70	60/70	38/44	40/45	51/51	60/70	60/70	51/51	60/70	60/70	60/70			
	DD20CP	14.9/19.8	50.83/67.55	41.3/47.6	67/75	70/70	80/80	52/60	60/90	51/51	60/70	60/70	51/51	60/70	60/70	60/70			
	DD30CP	21.6/28.8	73.69/98.25	60.0/69.3	90/102	90/90	110/110	75/87	80/90	51/51	60/70	60/70	51/51	60/70	60/70	60/70			
	DD40CP	29.7/39.6	101.32/135.10	82.5/95.2	119/134	125/125	150/150	104/119	110/125	51/51	60/70	60/70	51/51	60/70	60/70	60/70			

\* = For Canadian use only. Uses "P" fuses for inductive circuit.  
+ = Field installed only.

## 208/240 VOLT, THREE PHASE, 60 Hz, AUXILIARY ELECTRIC HEATER KITS CHARACTERISTICS AND APPLICATION

Single Power Supply For Both Unit and Heater Kit										Separate Power Supply For Both Unit and Heater Kit				
Unit Model No.	Heater Kit				Air Conditioner				Heater Kit			Air Conditioner		
	RXJJ-Heater Kit Nominal kW	No. of Sequence Steps	Rated Heater kW @ 208/240 V	Heater KBTU/Hr @ 208/240 V	Heater Amp. @ 208/240 V	Unit Min. Ampacity @ 208/240 V	Over Current Protective Device Size Min./Max. @ 208 V	Over Current Protective Device Size Min./Max. @ 240 V	Min. Ckt. Ampacity 208/240 V	Max. Fuse Size 208/240 V	Min. Circuit Ampacity 208/240 V	Over Current Protective Device Size Min./Max. @ 208 V	Over Current Protective Device Size Min./Max. @ 240 V	
RACDZT 120ACF	No Heat	—	—	—	—	54/54	70/80	70/80	—	—	54/54	70/80	70/80	
	DD10CP	1	7.4/9.9	25.25/33.77	20.6/23.8	54/54	70/80	70/80	26/30	30/30	54/54	70/80	70/80	
	DD15CP	1	10.8/14.4	36.84/49.13	30.0/34.6	54/54	70/80	70/80	38/44	40/45	54/54	70/80	70/80	
	DD20CP	2	14.9/19.8	50.83/67.55	41.3/47.6	62/70	70/80	70/80	52/60	60/60	54/54	70/80	70/80	
	DD30CP	2	21.6/28.8	73.69/98.25	60.0/69.3	85/97	90/90	100/100	75/87	80/90	54/54	70/80	70/80	
RACDZT 120ACG	No Heat	—	—	—	—	113/129	125/125	150/150	104/119	110/125	54/54	70/80	70/80	
	DD10CP	1	7.4/9.9	25.25/33.77	20.6/23.8	56/56	70/80	70/80	26/30	30/30	56/56	70/80	70/80	
	DD15CP	1	10.8/14.4	36.84/49.13	30.0/34.6	56/56	70/80	70/80	38/44	40/45	56/56	70/80	70/80	
	DD20CP	1	14.9/19.8	50.83/67.55	41.3/47.6	65/73	70/80	80/80	52/60	60/60	56/56	70/80	70/80	
	DD30CP	1	21.6/28.8	73.69/98.25	60.0/69.3	88/100	90/90	100/100	75/87	80/90	56/56	70/80	70/80	
RACDZT 120ACH	No Heat	—	—	—	—	116/132	125/125	150/150	104/119	110/125	56/56	70/80	70/80	
	DD10CP	1	7.4/9.9	25.25/33.77	20.6/23.8	58/58	70/90	70/90	—	—	58/58	70/90	70/90	
	DD15CP	1	10.8/14.4	36.84/49.13	30.0/34.6	58/59	70/90	70/90	26/30	30/30	58/58	70/90	70/90	
	DD20CP	1	14.9/19.8	50.83/67.55	41.3/47.6	67/75	70/90	80/90	38/44	40/45	58/58	70/90	70/90	
	DD30CP	1	21.6/28.8	73.69/98.25	60.0/69.3	90/102	90/90	110/110	52/60	60/60	58/58	70/90	70/90	
RACDZT 150ACF	No Heat	—	—	—	—	119/134	125/125	150/150	104/119	110/125	58/58	70/90	70/90	
	DD10CP	1	7.4/9.9	25.25/33.77	20.6/23.8	70/70	80/90	80/90	—	—	70/70	80/90	80/90	
	DD15CP	1	10.8/14.4	36.84/49.13	30.0/34.6	70/70	80/90	80/90	26/30	30/30	70/70	80/90	80/90	
	DD20CP	1	14.9/19.8	50.83/67.55	41.3/47.6	70/73	80/90	80/90	38/44	40/45	70/70	80/90	80/90	
	DD30CP	1	21.6/28.8	73.69/98.25	60.0/69.3	88/100	90/90	100/100	52/60	60/60	70/70	80/90	80/90	
RACDZT 150ACG	No Heat	—	—	—	—	117/132	125/125	150/150	104/119	110/125	70/70	80/90	80/90	
	DD10CP	1	7.4/9.9	25.25/33.77	20.6/23.8	75/75	90/90	90/90	—	—	75/75	90/90	90/90	
	DD15CP	1	10.8/14.4	36.84/49.13	30.0/34.6	75/75	90/90	90/90	26/30	30/30	75/75	90/90	90/90	
	DD20CP	1	14.9/19.8	50.83/67.55	41.3/47.6	75/80	90/90	90/90	38/44	40/45	75/75	90/90	90/90	
	DD30CP	1	21.6/28.8	73.69/98.25	60.0/69.3	95/107	100/100	110/110	52/60	60/60	75/75	90/90	90/90	
DD40CP	1	29.7/39.6	101.32/135.10	82.5/95.2	124/139	125/125	150/150	75/87	80/90	75/75	90/90	90/90		

\* = For Canadian use only. Uses "p" fuses for inductive circuit.  
+ = Field installed only.

480 VOLT, THREE PHASE, 60 Hz, AUXILIARY ELECTRIC HEATER KITS CHARACTERISTICS AND APPLICATION													
Single Power Supply For Both Unit and Heater Kit						Separate Power Supply For Both Unit and Heater Kit							
Unit Model No.	RXJJ- Heater Kit Nominal kW	No. of Sequence Steps	Heater Kit			Air Conditioner			Heater Kit			Air Conditioner	
			Rated Heater kW @ 208/240 V	Heater KBTU/Hr @ 208/240 V	Heater Amp. @ 208/240 V	Unit Min. Ampacity @ 208/240 V	Over Current Protective Device Size Min./Max. @ 208 V	Min. Ckt. Ampacity 208/240 V	Max. Fuse Size 208/240 V	Min. Circuit Ampacity 208/240 V	Over Current Protective Device Size Min./Max. @ 240 V		
RACDZT 090ADF	No Heat	—	—	—	—	17	20/25	—	—	—	17	20/25	—
	DD10DNV	9.9	33.77	11.9	19	19	20/25	15	15	17	17	20/25	—
	DD15DNV	14.4	49.13	17.3	26	26	30/30	22	25	17	17	20/25	—
	DD20DNV	19.8	67.55	23.8	34	34	35/35	30	30	17	17	20/25	—
	DD30DNV	28.8	98.25	34.6	48	48	50/50	44	45	17	17	20/25	—
DD40DNV	39.6	135.10	47.6	64	64	70/70	60	60	17	17	20/25	—	
RACDZT 090ADG	No Heat	—	—	—	—	19	25/25	—	—	—	19	25/25	—
	DD10DNV	9.9	33.77	11.9	21	21	25/25	15	15	19	19	25/25	—
	DD15DNV	14.4	49.13	17.3	28	28	30/30	22	25	19	19	25/25	—
	DD20DNV	19.8	67.55	23.8	36	36	40/40	30	30	19	19	25/25	—
	DD30DNV	28.8	98.25	34.6	49	49	50/50	44	45	19	19	25/25	—
DD40DNV	39.6	135.10	47.6	66	66	70/70	60	60	19	19	25/25	—	
RACDZT 102ADF	No Heat	—	—	—	—	21	25/30	—	—	—	21	25/30	—
	DD10DNV	9.9	33.77	11.9	21	21	25/25	15	15	21	21	25/30	—
	DD15DNV	14.4	49.13	17.3	26	26	30/30	22	25	21	21	25/30	—
	DD20DNV	19.8	67.55	23.8	35	35	35/35	30	30	21	21	25/30	—
	DD30DNV	28.8	98.25	34.6	48	48	50/50	44	45	21	21	25/30	—
DD40DNV	39.6	135.10	47.6	64	64	70/70	60	60	21	21	25/30	—	
RACDZT 102ADG	No Heat	—	—	—	—	22	25/30	—	—	—	22	25/30	—
	DD10DNV	9.9	33.77	11.9	22	22	25/30	15	15	22	22	25/30	—
	DD15DNV	14.4	49.13	17.3	28	28	30/30	22	25	22	22	25/30	—
	DD20DNV	19.8	67.55	23.8	36	36	40/40	30	30	22	22	25/30	—
	DD30DNV	28.8	98.25	34.6	49	49	50/50	44	45	22	22	25/30	—
DD40DNV	39.6	135.10	47.6	66	66	70/70	60	60	22	22	25/30	—	
RACDZT 102ADH	No Heat	—	—	—	—	24	30/35	—	—	—	24	30/35	—
	DD10DNV	9.9	33.77	11.9	24	24	30/35	15	15	24	24	30/35	—
	DD15DNV	14.4	49.13	17.3	30	30	30/35	22	25	24	24	30/35	—
	DD20DNV	19.8	67.55	23.8	38	38	40/40	30	30	24	24	30/35	—
	DD30DNV	28.8	98.25	34.6	51	51	60/60	44	45	24	24	30/35	—
DD40DNV	39.6	135.10	47.6	67	67	70/70	60	60	24	24	30/35	—	

\* = For Canadian use only. Uses "p" fuses for inductive circuit.  
+ = Field installed only.

**480 VOLT, THREE PHASE, 60 HZ, AUXILIARY ELECTRIC HEATER KITS CHARACTERISTICS AND APPLICATION**

Single Power Supply For Both Unit and Heater Kit										Separate Power Supply For Both Unit and Heater Kit							
Unit Model No.	RXJJ-Heater Kit Nominal kW	No. of Sequence Steps	Heater Kit				Air Conditioner				Heater Kit			Air Conditioner			
			Rated Heater kW @ 208/240 V	Heater KBTU/Hr @ 208/240 V	Heater Amp. @ 208/240 V	Unit Min. Ckt. Ampacity @ 208/240 V	Over Current Protective Device Size Min./Max. @ 208 V	Over Current Protective Device Size Min./Max. @ 240 V	Min. Ckt. Ampacity 208/240 V	Max. Fuse Size 208/240 V	Min. Circuit Ampacity 208/240 V	Over Current Protective Device Size Min./Max. @ 208 V	Over Current Protective Device Size Min./Max. @ 240 V				
RACDZT 120ADF	No Heat	—	—	—	—	26	30/35	—	—	26	30/35	—	—	26	30/35	—	—
	DD10DNV	1	9.9	33.77	11.9	26	30/35	—	—	26	30/35	15	15	26	30/35	—	—
	DD15DNV	1	14.4	49.13	17.3	27	30/35	—	—	27	30/35	22	25	26	30/35	—	—
	DD20DNV	2	19.8	67.55	23.8	35	35/35	—	—	35	35/35	30	30	26	30/35	—	—
	DD30DNV	2	28.8	98.25	34.6	49	50/50	—	—	49	50/50	44	45	26	30/35	—	—
DD40DNV	2	39.6	135.10	47.6	65	70/70	—	—	65	70/70	60	60	26	30/35	—	—	
RACDZT 120ADG	No Heat	—	—	—	—	27	35/40	—	—	27	35/40	—	—	27	35/40	—	—
	DD10DNV	1	9.9	33.77	11.9	27	35/40	—	—	27	35/40	15	15	27	35/40	—	—
	DD15DNV	1	14.4	49.13	17.3	28	35/40	—	—	28	35/40	22	25	27	35/40	—	—
	DD20DNV	2	19.8	67.55	23.8	37	40/40	—	—	37	40/40	30	30	27	35/40	—	—
	DD30DNV	2	28.8	98.25	34.6	50	50/50	—	—	50	50/50	44	45	27	35/40	—	—
DD40DNV	2	39.6	135.10	47.6	66	70/70	—	—	66	70/70	60	60	27	35/40	—	—	
RACDZT 120ADH	No Heat	—	—	—	—	28	35/40	—	—	28	35/40	—	—	28	35/40	—	—
	DD10DNV	1	9.9	33.77	11.9	28	35/40	—	—	28	35/40	15	15	28	35/40	—	—
	DD15DNV	1	14.4	49.13	17.3	30	35/40	—	—	30	35/40	22	25	28	35/40	—	—
	DD20DNV	2	19.8	67.55	23.8	38	40/40	—	—	38	40/40	30	30	28	35/40	—	—
	DD30DNV	2	28.8	98.25	34.6	51	60/60	—	—	51	60/60	44	45	28	35/40	—	—
DD40DNV	2	39.6	135.10	47.6	66	70/70	—	—	66	70/70	60	60	28	35/40	—	—	
RACDZT 150ADF	No Heat	—	—	—	—	34	40/40	—	—	34	40/40	—	—	34	40/40	—	—
	DD10DNV	1	9.9	33.77	11.9	34	40/40	—	—	34	40/40	15	15	34	40/40	—	—
	DD15DNV	1	14.4	49.13	17.3	34	40/40	—	—	34	40/40	22	25	34	40/40	—	—
	DD20DNV	2	19.8	67.55	23.8	37	40/40	—	—	37	40/40	30	30	34	40/40	—	—
	DD30DNV	2	28.8	98.25	34.6	50	50/50	—	—	50	50/50	44	45	34	40/40	—	—
DD40DNV	2	39.6	135.10	47.6	66	70/70	—	—	66	70/70	60	60	34	40/40	—	—	
RACDZT 150ADG	No Heat	—	—	—	—	37	40/45	—	—	37	40/45	—	—	37	40/45	—	—
	DD10DNV	1	9.9	33.77	11.9	37	40/45	—	—	37	40/45	15	15	37	40/45	—	—
	DD15DNV	1	14.4	49.13	17.3	37	40/45	—	—	37	40/45	22	25	37	40/45	—	—
	DD20DNV	2	19.8	67.55	23.8	40	40/45	—	—	40	40/45	30	30	37	40/45	—	—
	DD30DNV	2	28.8	98.25	34.6	54	60/60	—	—	54	60/60	44	45	37	40/45	—	—
DD40DNV	2	39.6	135.10	47.6	70	70/70	—	—	70	70/70	60	60	37	40/45	—	—	

\*= For Canadian use only. Uses "P" fuses for inductive circuit.  
+ = Field installed only.

600 VOLT, THREE PHASE, 60 Hz, AUXILIARY ELECTRIC HEATER KITS CHARACTERISTICS AND APPLICATION														
Single Power Supply For Both Unit and Heater Kit						Separate Power Supply For Both Unit and Heater Kit								
Unit Model No.	RXJJ-Heater Kit Nominal kW	No. of Sequence Steps	Heater Kit			Air Conditioner			Heater Kit			Air Conditioner		
			Rated Heater kW @ 600 V	Heater KBTU/Hr @ 600 V	Heater Amp. @ 600 V	Unit Min. Ckt. Ampacity @ 208/240 V	Over Current Protective Device Size Min./Max. @ 600 V	Min. Ckt. Ampacity 600 V	Max. Fuse Size 600 V	Min. Circuit Ampacity 600 V	Over Current Protective Device Size Min./Max. @ 600 V			
RACDZT 090AYF	No Heat	—	—	—	—	15	20/20	—	—	—	—	15	20/20	—
	DD10Y	1	10.0	34.12	9.6	16	20/20	34.12	9.6	16	15	15	20/20	—
	DD15Y	1	15.0	51.17	14.4	22	25/25	51.17	14.4	18	20	15	20/20	—
	DD20Y	2	20.0	68.23	19.2	28	30/30	68.23	19.2	24	25	15	20/20	—
	DD30Y	2	30.0	102.35	28.9	40	40/40	102.35	28.9	37	40	15	20/20	—
DD40Y	2	40.0	136.46	38.5	52	60/60	136.46	38.5	49	50	15	20/20	—	
RACDZT 090AYG	No Heat	—	—	—	—	16	20/20	—	—	—	—	16	20/20	—
	DD10Y	1	10.0	34.12	9.6	17	20/20	34.12	9.6	12	15	16	20/20	—
	DD15Y	1	15.0	51.17	14.4	23	25/25	51.17	14.4	18	20	16	20/20	—
	DD20Y	2	20.0	68.23	19.2	29	30/30	68.23	19.2	24	25	16	20/20	—
	DD30Y	2	30.0	102.35	28.9	41	45/45	102.35	28.9	37	40	16	20/20	—
DD40Y	2	40.0	136.46	38.5	53	60/60	136.46	38.5	49	50	16	20/20	—	
RACDZT 090AYH	No Heat	—	—	—	—	16	20/20	—	—	—	—	16	20/20	—
	DD10Y	1	10.0	34.12	9.6	17	20/20	34.12	9.6	12	15	16	20/20	—
	DD15Y	1	15.0	51.17	14.4	23	25/25	51.17	14.4	18	20	16	20/20	—
	DD20Y	2	20.0	68.23	19.2	29	30/30	68.23	19.2	24	25	16	20/20	—
	DD30Y	2	30.0	102.35	28.9	41	45/45	102.35	28.9	37	40	16	20/20	—
DD40Y	2	40.0	136.46	38.5	53	60/60	136.46	38.5	49	50	16	20/20	—	
RACDZT 102AYF	No Heat	—	—	—	—	16	20/25	—	—	—	—	16	20/25	—
	DD10Y	1	10.0	34.12	9.6	16	20/25	34.12	9.6	12	15	16	20/25	—
	DD15Y	1	15.0	51.17	14.4	22	25/25	51.17	14.4	18	20	16	20/25	—
	DD20Y	2	20.0	68.23	19.2	28	30/30	68.23	19.2	24	25	16	20/25	—
	DD30Y	2	30.0	102.35	28.9	40	40/40	102.35	28.9	37	40	16	20/25	—
DD40Y	2	40.0	136.46	38.5	52	60/60	136.46	38.5	49	50	16	20/25	—	
RACDZT 102AYG	No Heat	—	—	—	—	17	20/25	—	—	—	—	17	20/25	—
	DD10Y	1	10.0	34.12	9.6	17	20/25	34.12	9.6	12	15	17	20/25	—
	DD15Y	1	15.0	51.17	14.4	23	25/25	51.17	14.4	18	20	17	20/25	—
	DD20Y	2	20.0	68.23	19.2	29	30/30	68.23	19.2	24	25	17	20/25	—
	DD30Y	2	30.0	102.35	28.9	41	45/45	102.35	28.9	37	40	17	20/25	—
DD40Y	2	40.0	136.46	38.5	53	60/60	136.46	38.5	49	50	17	20/25	—	

\* = For Canadian use only. Uses "p" fuses for inductive circuit.  
+ = Field installed only.

## 600 VOLT, THREE PHASE, 60 Hz, AUXILIARY ELECTRIC HEATER KITS CHARACTERISTICS AND APPLICATION

Separate Power Supply For Both Unit and Heater Kit										
Unit Model No.	Heater Kit					Air Conditioner				
	RXJJ-Heater Kit Nominal kW	No. of Sequence Steps	Rated Heater kW @ 600 V	Heater KBTU/Hr @ 600 V	Heater Amp. @ 600 V	Unit Min. Ckt. Ampacity @ 208/240 V	Over Current Protective Device Size		Min. Circuit Ampacity 600 V	Over Current Protective Device Size Min./Max. @ 600 V
							Min./Max. @ 600 V			
RACDZT 102AYH	No Heat	—	—	—	—	17	20/25	—	17	20/25
	DD10Y	1	10.0	34.12	9.6	17	20/25	—	17	20/25
	DD15Y	1	15.0	51.17	14.4	23	25/25	—	17	20/25
	DD20Y	2	20.0	68.23	19.2	29	30/30	—	17	20/25
	DD30Y	2	30.0	102.35	28.9	41	45/45	—	17	20/25
RACDZT 120AYF	DD40Y	2	40.0	136.46	38.5	53	60/60	—	17	20/25
	No Heat	—	—	—	—	19	25/25	—	19	25/25
	DD10Y	1	10.0	34.12	9.6	19	25/25	—	19	25/25
	DD15Y	1	15.0	51.17	14.4	22	25/25	—	19	25/25
	DD20Y	2	20.0	68.23	19.2	28	30/30	—	19	25/25
RACDZT 120AYG	DD30Y	2	30.0	102.35	28.9	40	40/40	—	19	25/25
	DD40Y	2	40.0	136.46	38.5	52	60/60	—	19	25/25
	No Heat	—	—	—	—	20	25/30	—	20	25/30
	DD10Y	1	10.0	34.12	9.6	20	25/30	—	20	25/30
	DD15Y	1	15.0	51.17	14.4	23	25/30	—	20	25/30
RACDZT 120AYH	DD20Y	2	20.0	68.23	19.2	29	30/30	—	20	25/30
	DD30Y	2	30.0	102.35	28.9	41	45/45	—	20	25/30
	DD40Y	2	40.0	136.46	38.5	53	60/60	—	20	25/30
	No Heat	—	—	—	—	20	25/30	—	20	25/30
	DD10Y	1	10.0	34.12	9.6	20	25/30	—	20	25/30
RACDZT 150AYF	DD15Y	1	15.0	51.17	14.4	23	25/30	—	20	25/30
	DD20Y	2	20.0	68.23	19.2	29	30/30	—	20	25/30
	DD30Y	2	30.0	102.35	28.9	41	45/45	—	20	25/30
	DD40Y	2	40.0	136.46	38.5	53	60/60	—	20	25/30
	No Heat	—	—	—	—	25	30/30	—	25	30/30
RACDZT 150AYG	DD10Y	1	10.0	34.12	9.6	25	30/30	—	25	30/30
	DD15Y	1	15.0	51.17	14.4	25	30/30	—	25	30/30
	DD20Y	2	20.0	68.23	19.2	30	30/30	—	25	30/30
	DD30Y	2	30.0	102.35	28.9	42	45/45	—	25	30/30
	DD40Y	2	40.0	136.46	38.5	54	60/60	—	25	30/30
RACDZT 150AYH	No Heat	—	—	—	—	27	30/30	—	27	30/30
	DD10Y	1	10.0	34.12	9.6	27	30/30	—	27	30/30
	DD15Y	1	15.0	51.17	14.4	27	30/30	—	27	30/30
	DD20Y	2	20.0	68.23	19.2	32	35/35	—	27	30/30
	DD30Y	2	30.0	102.35	28.9	44	45/45	—	27	30/30
DD40Y	2	40.0	136.46	38.5	56	60/60	—	27	30/30	

\* = For Canadian use only. Uses "P" fuses for inductive circuit.  
+ = Field installed only.



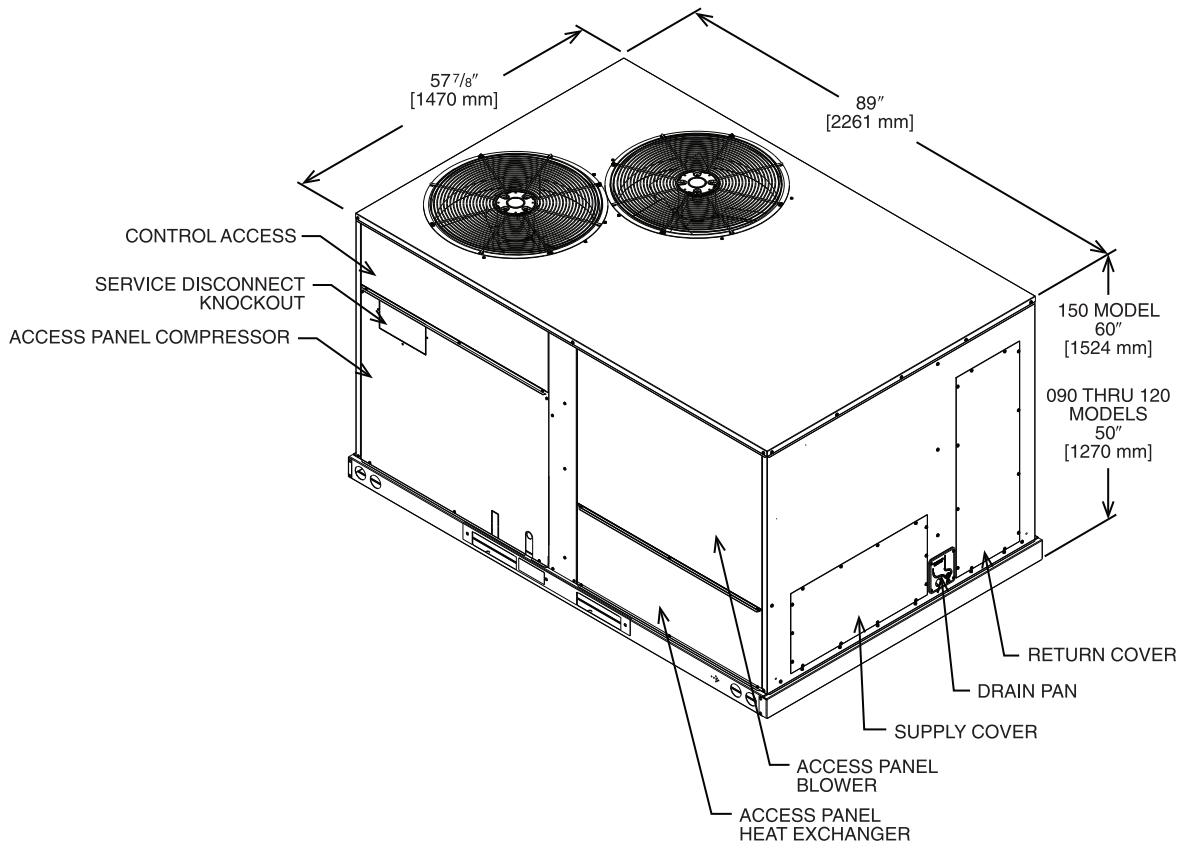

Illustration  
 ST-A1273-26-00

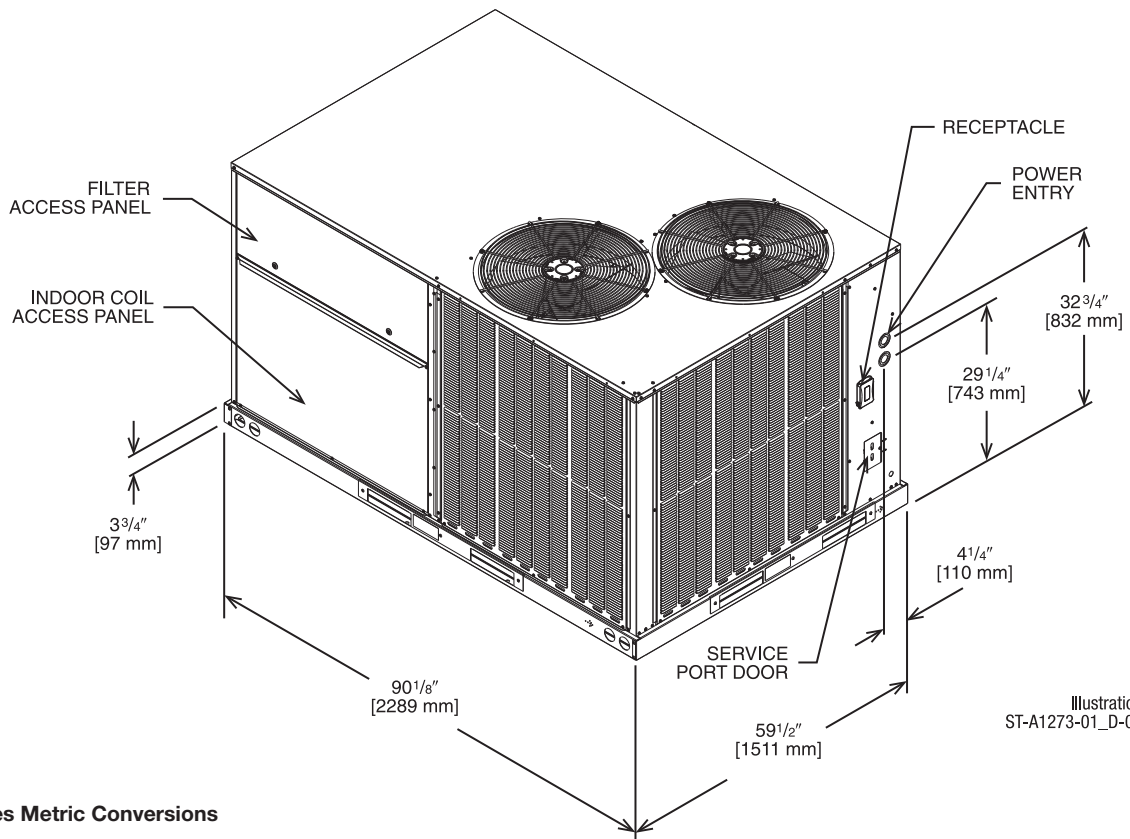
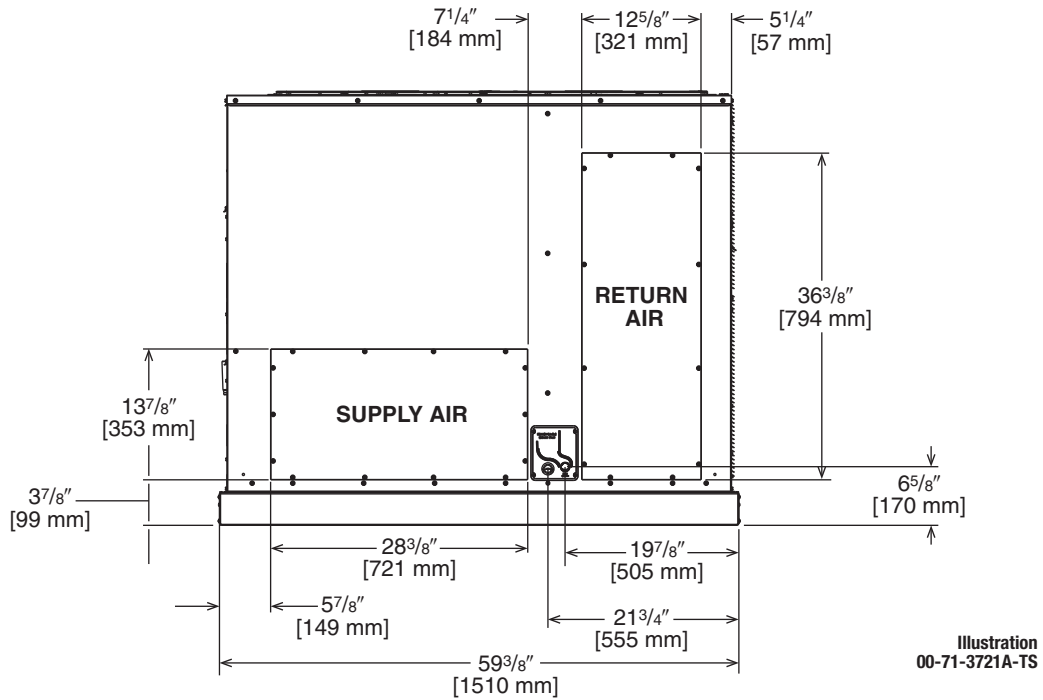

Illustration  
 ST-A1273-01\_D-00

[ ] Designates Metric Conversions

**SUPPLY AND RETURN DIMENSIONS FOR HORIZONTAL APPLICATIONS**



**SUPPLY AND RETURN DIMENSIONS FOR DOWNFLOW APPLICATIONS**

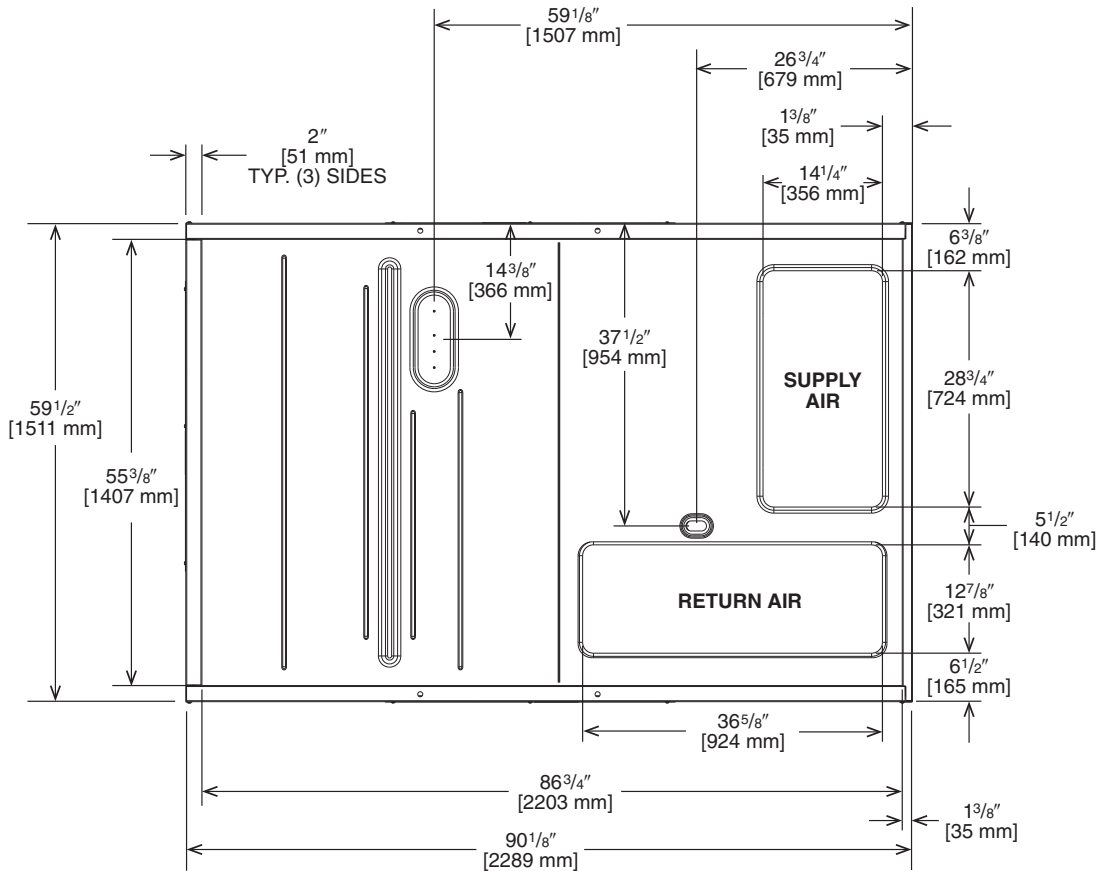

[ ] Designates Metric Conversions

## WEIGHTS

Capacity Tons [kW]	Corner Weights by Percentage			
	A	B	C	D
7.5-12.5 [21.1-44.0]	26%	34%	17%	23%

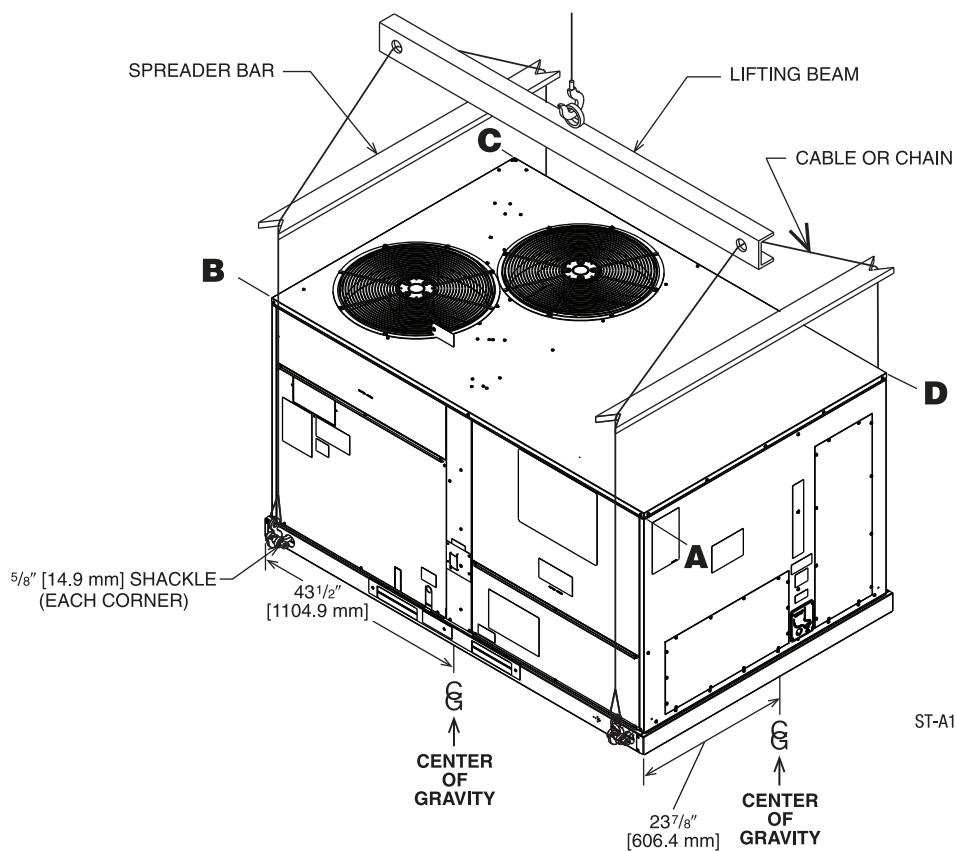

Illustration  
ST-A1273-01\_J-00

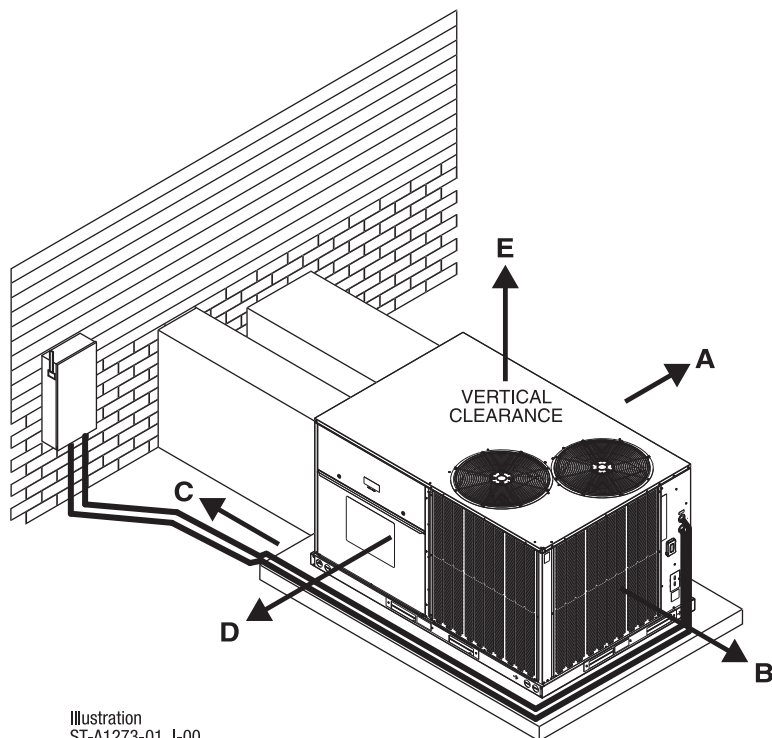

Illustration  
ST-A1273-01\_J-00

### CLEARANCES

The following minimum clearances must be observed for proper unit performance and serviceability.

RECOMMENDED CLEARANCE In. [mm]	LOCATION
48 [1219]	A - FRONT
24 [609]	B - CONDENSER END
48 [1219] ①	C - DUCT END
24 [609] ②	D - FILTER SIDE
60 [1524]	E - ABOVE

① 18" [457 mm] MINIMUM IF DRAINPAN WILL NOT BE REMOVED.

② 48" [1219 MM] MINIMUM IF ECONOMIZER IS INSTALLED.

## FIELD INSTALLED ACCESSORY EQUIPMENT

Accessory	Model Number	Shipping Weight Lbs. [kg]	Installed Weight Lbs. [kg]	Factory Installation Available?
Economizer w/Single Enthalpy (Downflow)	RXRD-01MDDAM3	86 [39.0]	57 [25.9]	Yes
Economizer w/Single Enthalpy (Horizontal)	RXRD-01MDHAM3	84 [38.1]	55 [24.9]	Yes
Economizer-w/Single Enthalpy (Downflow) DDC	RXRD-01MDDBM3	86 [39.0]	57 [25.9]	No
Economizer w/Single Enthalpy (Horizontal) DDC	RXRD-01MDHBM3	84 [38.1]	55 [24.9]	No
Dual Enthalpy Kit	RXRX-BV01	1 [.5]	1 [.5]	No
Dual Enthalpy Kit DDC	RXRX-BV02	1 [.5]	1 [.5]	No
Carbon Dioxide Sensor (Wall Mount)	RXRX-AR02	3 [1.4]	2 [1.0]	No
Power Exhaust	RXRX-CDF01C	58 [26.3]	48 [21.8]	No
Power Exhaust	RXRX-CDF01D	50 [22.7]	44 [20.0]	No
Manual Fresh Air Damper	RXRF-ADA1	15 [6.8]	12 [5.4]	No
Motorized Fresh Air Damper	RXRF-ADB1	38 [17.2]	31 [14.06]	No
Motorized Fresh Air Damper (DDC)	RXRF-ADC1	38 [17.2]	31 [14.06]	No
Roofcurb, 14'	RXKG-DDD14	109 [49.4]	104 [47.2]	No
Roofcurb, 24'	RXKG-DDD24	145 [65.8]	140 [63.5]	No
Roofcurb Adapter	RXRX-DDCAE	235 [106.6]	215 [97.5]	No
Concentric Diffuser 7.5/8.5 Ton Flush	RXRN-AEF2000	235 [106.6]	215 [97.5]	No
Concentric Diffuser 10.0 Ton Flush	RXRN-AEF3415	30 [13.6]	25 [11.3]	No
Concentric Diffuser 12.5 Ton Flush	RXRN-AEF3618	250 [113.4]	130 [59]	No
Concentric Diffuser 7.5/8.5 Ton Drop	RXRN-AED2000	275 [124.7]	170 [77.1]	No
Concentric Diffuser 10.0 Ton Drop	RXRN-AED3415	35 [15.9]	30 [13.6]	No
Concentric Diffuser 12.5 Ton Drop	RXRN-AED3618	270 [122.5]	160 [72.6]	No
Concentric Adapter 7.5/8.5 Ton Drop	RXMC-DD01	300 [136.1]	180 [81.6]	No
Concentric Adapter 10 Ton Drop	RXMC-DD02	25 [11.3]	20 [9.1]	No
Concentric Adapter 12.5 Ton Drop	RXMC-DD03	75 [34]	65 [29.5]	No
Outdoor Coil Louver Kit - ACD/090/102/120	RXRX-ADD04A	52 [23.6]	47 [21.3]	Yes
Outdoor Coil Louver Kit - ACD150	RXRX-ADD04B	43 [19.5]	39 [17.7]	Yes
Unwired Convenience Outlet	RXRX-BN01	2 [1.0]	1.5 [.7]	Yes
Unfused Service Disconnect	RXRX-BP01	10 [4.5]	9 [4.1]	Yes
Comfort Alert (1 Per Compressor)	RXRX-AZ01 DDC	3 [1.5]	2 [0.9]	Yes
Comfort Alert (1 Per Compressor)	RXRX-AZ02	3 [1.5]	2 [0.9]	Yes
BACnet Communication Card	RXRX-AY01	1 [0.5]	1 [0.5]	No
LonWorks Communication Card	RXRX-AY02	1 [0.5]	1 [0.5]	No
Room Humidity Sensor	RHC-ZNS4	1 [0.5]	1 [0.5]	No
Room Temperature and Relative Humidity Sensor	RHC-ZNS5	1 [0.5]	1 [0.5]	No
Low-Ambient Control Kit	RXRZ-A04	4 [1.8]	3 [1.4]	Yes
Freeze Stat Kit	RXRX-AM01	2 [1.0]	1.5 [.7]	Yes
MERV 8 Filter 7.5 - 10 Ton	RXMF-M08A22020	2 [0.9]	1 [0.45]	No
MERV 8 Filter 12.5 Ton	RXMF-M08A22520	2 [0.9]	1 [0.45]	No
MERV 13 Filter 7.5 - 10 Ton	RXMF-M13A22020	2 [0.9]	1 [0.45]	No
MERV 13 Filter 12.5 Ton	RXMF-M13A22520	2 [0.9]	1 [0.45]	No
Flue Diverter	RXRX-DFG04	5 [2.3]	4 [1.8]	No

[ ] Designates Metric Conversions

## FIELD INSTALLED ACCESSORY EQUIPMENT (Con't.)

Accessory	Model Number	Shipping Weight Lbs. [kg]	Installed Weight Lbs. [kg]	Factory Installation Available?
Variable Frequency Drive Kit	RXXR-AC02	9.1 [4.1]	7.6 [3.4]	No
	RXXR-AC03	11.7 [5.3]	10.2 [4.6]	No
	RXXR-AC05	11.7 [5.3]	10.2 [4.6]	No
	RXXR-AD02	9.4 [4.3]	7.9 [3.6]	No
	RXXR-AD03	12.3 [5.6]	10.8 [4.9]	No
	RXXR-AD05	12.3 [5.6]	10.8 [4.9]	No
	RXXR-CC02	9.1 [4.1]	7.6 [3.4]	No
	RXXR-CC03	11.7 [5.3]	10.2 [4.6]	No
	RXXR-CC05	11.7 [5.3]	10.2 [4.6]	No
	RXXR-CD02	9.4 [4.3]	7.9 [3.6]	No
	RXXR-CD03	12.3 [5.6]	10.8 [4.9]	No
	RXXR-CD05	12.3 [5.6]	10.8 [4.9]	No
Electric Heater Kits	RXJJ-DD10CP	30 [13.6]	27.5 [12.5]	Yes
	RXJJ-DD15CP	32 [14.5]	29.5 [13.4]	Yes
	RXJJ-DD20CP	34 [15.4]	31.5 [14.3]	Yes
	RXJJ-DD30CP	37 [16.8]	34.5 [15.6]	Yes
	RXJJ-DD40CP	40 [18.1]	37.5 [17]	Yes
	RXJJ-DD10DNV	30 [13.6]	27.5 [12.5]	Yes
	RXJJ-DD15DNV	32 [14.5]	29.5 [13.4]	Yes
	RXJJ-DD20DNV	34 [15.4]	31.5 [14.3]	Yes
	RXJJ-DD30DNV	37 [16.8]	34.5 [15.6]	Yes
	RXJJ-DD40DNV	40 [18.1]	37.5 [17]	Yes
Single Point Wiring Kit	RXJX-AC0605	23 [10.4]	25 [11.3]	No
	RXJX-AC0805	24 [10.9]	26 [11.8]	No
	RXJX-AD0605	25 [11.3]	27 [12.2]	No
	RXJX-AC0909	26 [11.8]	28 [12.7]	No
	RXJX-AD0609	25 [11.3]	27 [12.2]	No

[ ] Designates Metric Conversions

### VARIABLE FREQUENCY DRIVE KIT **RXXR – A C 02**

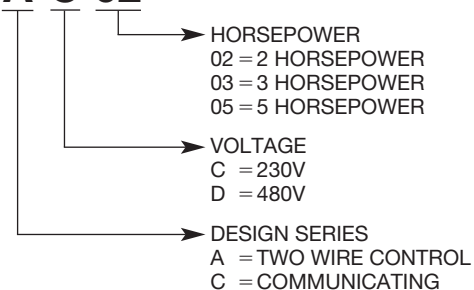

### SINGLE POINT WIRING KIT **RXJX – A C 09 09**

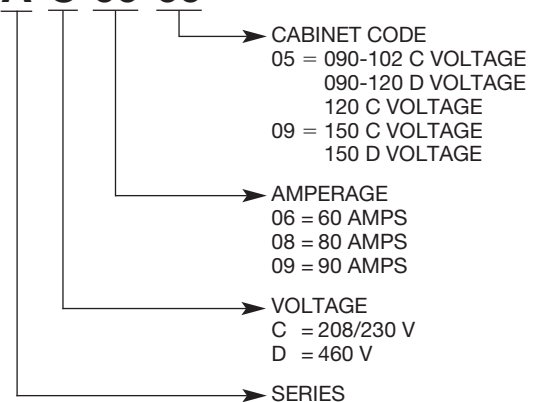

## FLUSH MOUNT ROOM TEMPERATURE SENSORS FOR NETWORKED DDC APPLICATIONS



**ROOM TEMPERATURE SENSOR      ZNS-101**  
**with TIMED OVERRIDE BUTTON**

10k $\Omega$  room temperature sensor transmits room temperature to DDC system. Timed override button allows tenant to change from unoccupied temperature setpoint to occupied temperature setpoint for a preset time.



**ROOM TEMPERATURE SENSOR      ZNS-102**  
**with TIMED OVERRIDE BUTTON and STATUS INDICATOR**

10k $\Omega$  room temperature sensor transmits room temperature to DDC system. Timed override button allows tenant to change from unoccupied temperature setpoint to occupied temperature setpoint for a preset time. Status Indicator Light transmits ALARM flash code to occupied space.



**ROOM TEMPERATURE SENSOR      ZNS-103**  
**with SETPOINT ADJUSTMENT and TIMED OVERRIDE BUTTON**

10k $\Omega$  room temperature sensor with setpoint adjustment transmits room temperature to DDC system along with desired occupied room temperature setpoint. Timed override button allows tenant to change from unoccupied temperature setpoint to occupied temperature setpoint for a preset time.

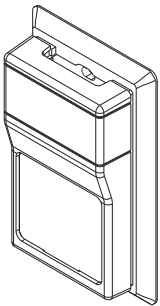

**ROOM HUMIDITY SENSOR      RHC-ZNS4**

Transmits room relative humidity to DDC System.

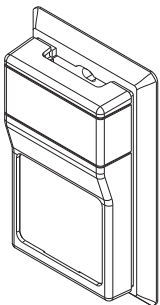

**ROOM TEMPERATURE AND RELATIVE HUMIDITY SENSOR      RHC-ZNS5**

Transmits room temperature and relative humidity to DDC System.



## COMMUNICATION CARDS

### Field Installed



#### **BACnet® COMMUNICATION CARD RXRX-AY01**

The field installed BACnet® Communication Card allows the RTU-C unit controller to communicate with a third party building management system that supports the BACnet Application Specific Controller device profile. The BACnet® Communication Module plugs onto the unit RTU-C controller and allows communication between the RTU-C and the BACnet MSTP network.



#### **LonWorks® COMMUNICATION CARD RXRX-AY02**

The field installed LonWorks® Communication Card allows the RTU-C unit controller to communicate with a third party building management system that supports the LonMark Space Comfort Controller (SCC) functional profile or LonMark Discharge Air Controller (DAC) functional profile. The LonMark Communication Module plugs onto the RTU-C controller and allows communication between the RTU-C and a LonWorks Network.

# NON-DDC ECONOMIZER FOR DOWNFLOW DUCT INSTALLATION

## Use to Select Factory Installed Options Only

**RXRD-01MDDAM3—Single Enthalpy (Outdoor) and AXRD-SJCM3**

**Single Enthalpy with Smoke Detector**

**RRX-BV02—Dual Enthalpy Upgrade Kit**

**RRX-AR02—Optional Wall-Mounted CO<sub>2</sub> Sensor**

- Features **Honeywell** Controls
- Available Factory Installed or Field Accessory
- Gear Driven Direct Drive Actuator
- Fully Modulating (0-100%)
- Low Leakage Dampers
- Slip-In Design for Easy Installation
- Standard Barometric Relief Damper
- Single Enthalpy with Dual Enthalpy Upgrade Kit Available
- CO<sub>2</sub> Input Sensor Available
- Field Assembled Hood Ships with Economizer
- Economizer Ships Complete for Downflow Duct Application
- Optional Remote Minimum Position Potentiometer (270 ohm) (Honeywell #S963B1136) is Available from Prostock
- Field Installed Power Exhaust Available
- Prewired for Smoke Detector
- If connected to a Building Automation System (BAS), all economizer functions can be viewed on the (BAS) or 16 x 2 LCD screen
- If connected to thermostat, all economizer functions can be viewed on 16 x 2 LCD screen

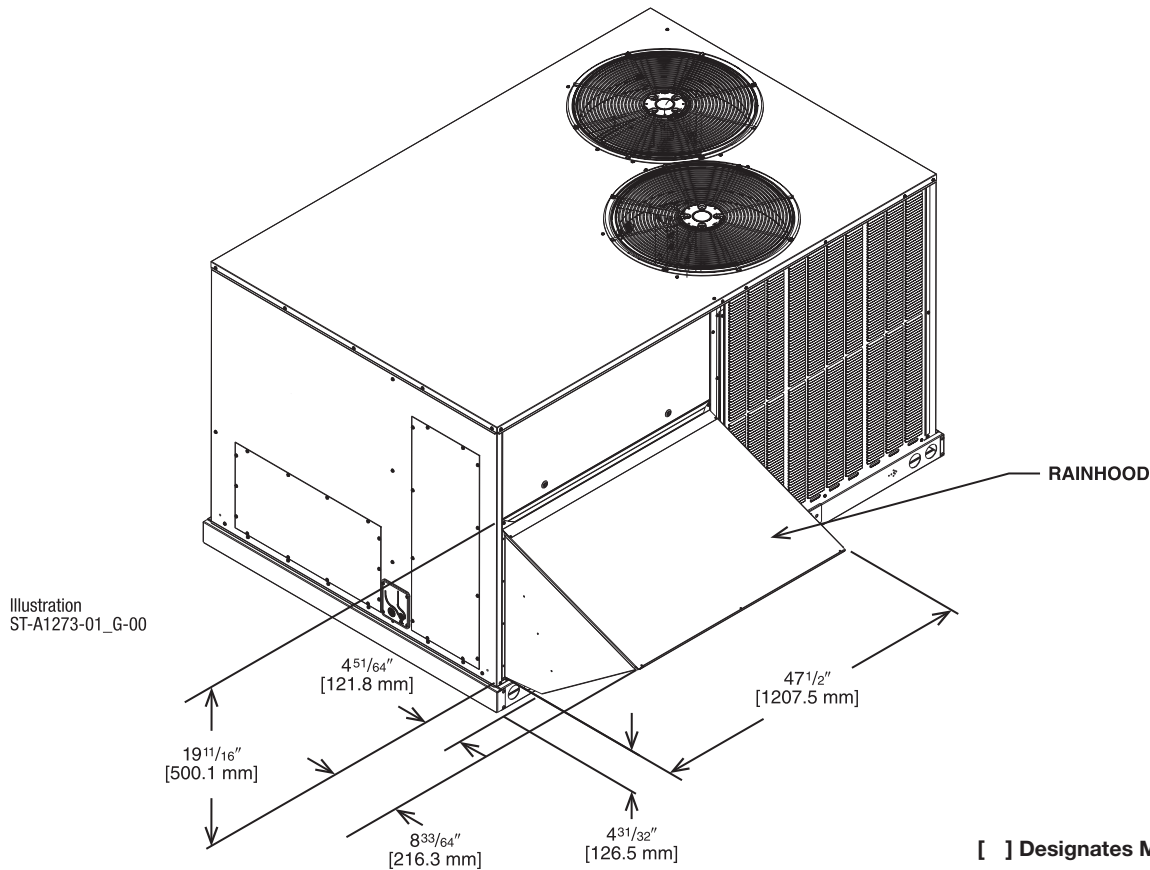
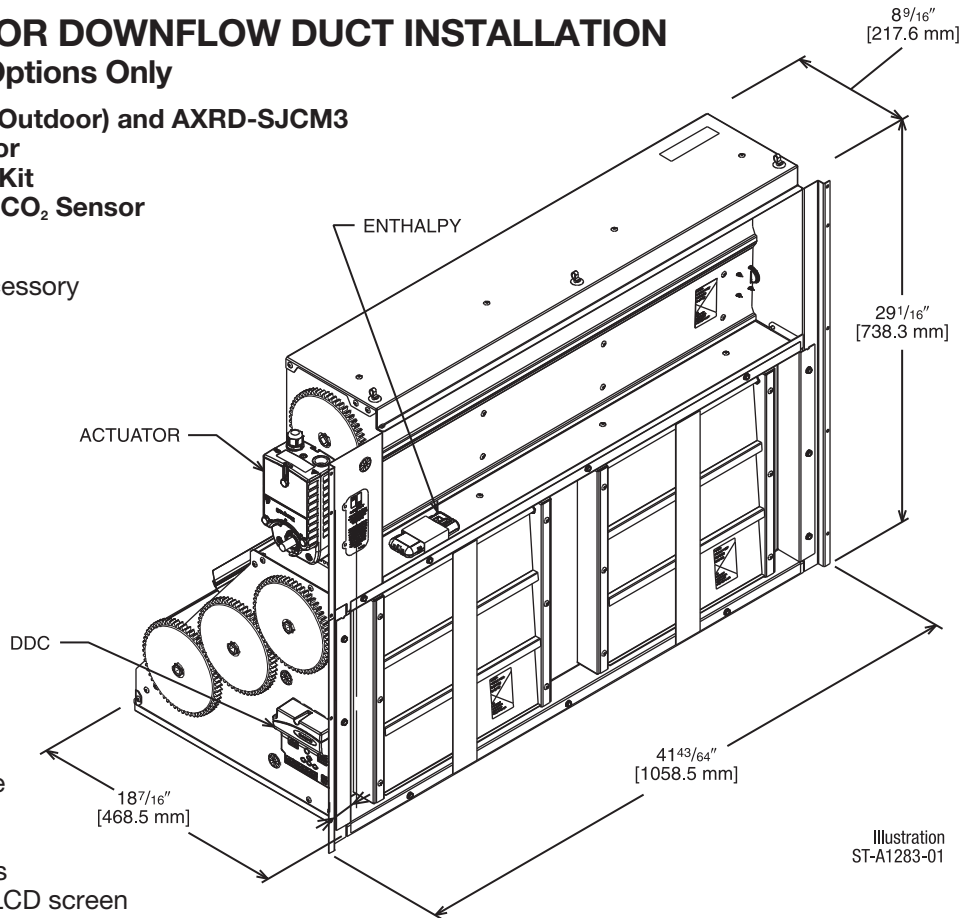

# NON-DDC ECONOMIZER FOR HORIZONTAL DUCT INSTALLATION

Field Installed Only

**RXRD-01DAH3—Single Enthalpy (Outdoor)**

**RXRX-BV01—Dual Enthalpy Upgrade Kit**

**RXRX-AR02—Wall-mounted CO<sub>2</sub> Sensor**

- Features **Honeywell** Controls
- Available as a Field Installed Accessory Only
- Gear Driven Direct Drive Actuator
- Fully Modulating (0-100%)
- Low Leakage Dampers
- Slip-In Design for Easy Installation
- Standard Barometric Relief Damper
- Single Enthalpy with Dual Enthalpy Upgrade Kit Available
- CO<sub>2</sub> Input Sensor Available
- Field Assembled Hood Ships with Economizer
- Economizer Ships Complete for Horizontal Duct Application
- Optional Remote Minimum Position Potentiometer (270 ohm) (Honeywell #S963B1136) is Available from Prostock
- Field Installed Power Exhaust Available
- If connected to a Building Automation System (BAS), all economizer functions can be viewed on the (BAS) or 16 x 2 LCD screen
- If connected to thermostat, all economizer functions can be viewed on 16 x 2 LCD screen

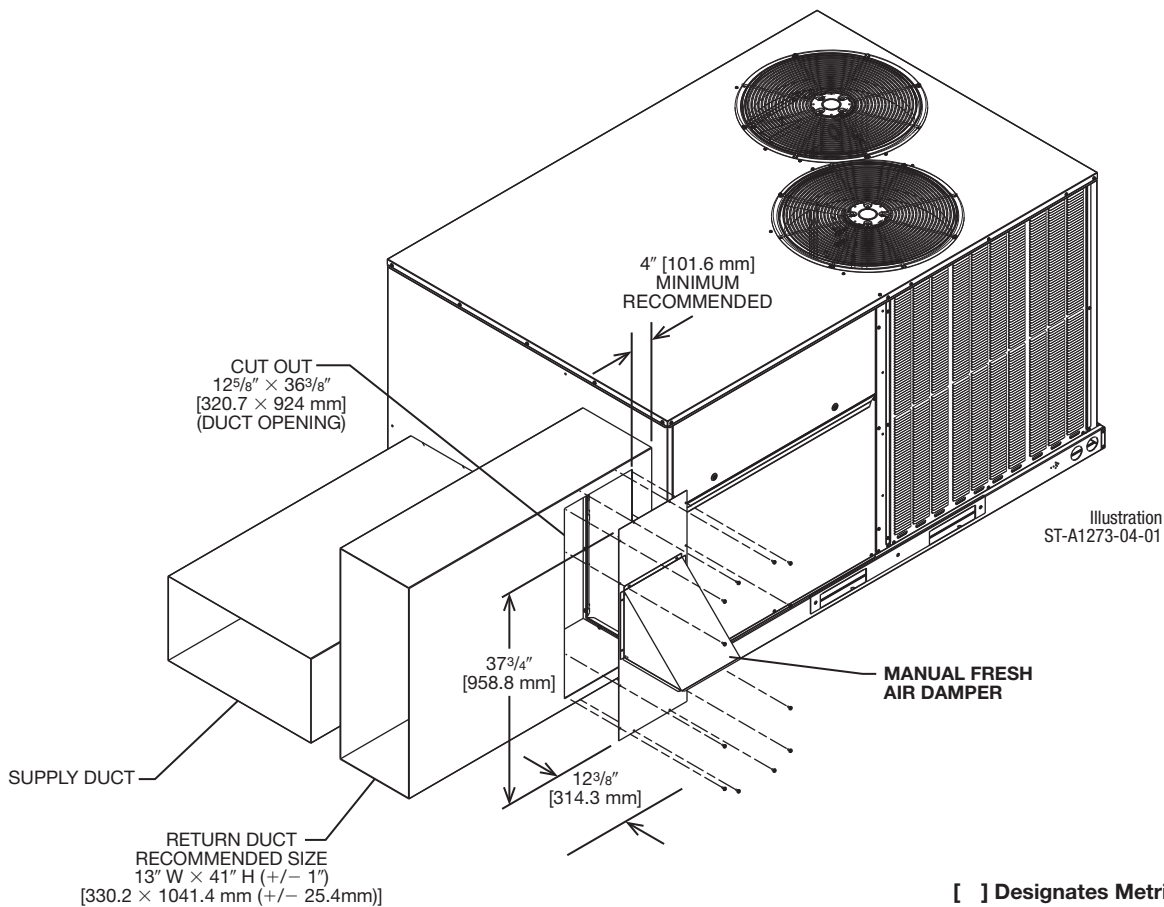
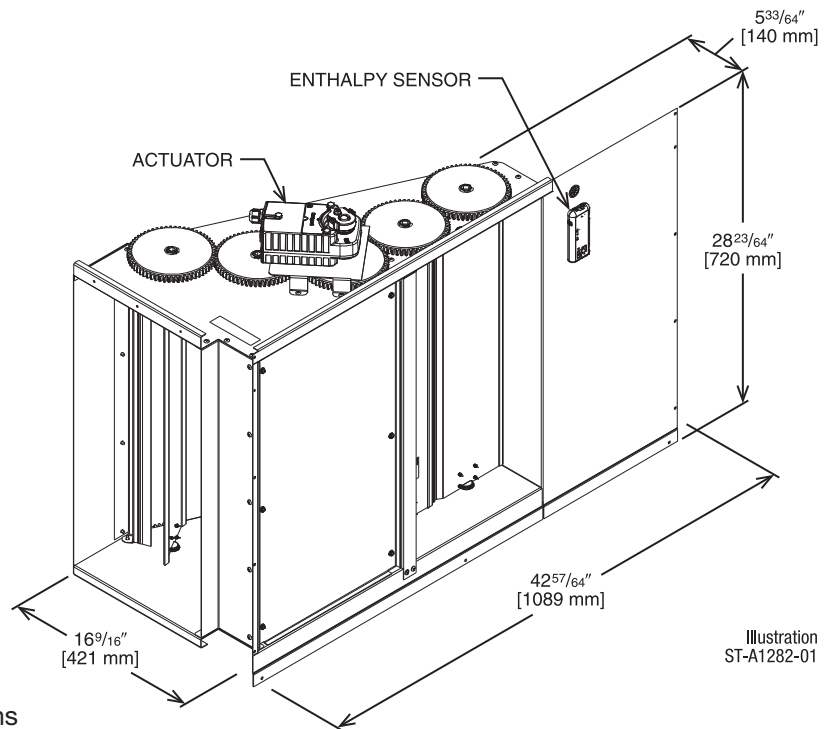

[ ] Designates Metric Conversions

# POWER EXHAUST KIT FOR RXRD-01MDDAM3, RXRD-01MDDBM3, RXRD-01MDHAM3, RXRD-01MDHBM3 ECONOMIZERS

RXXR-CDF01

\*Voltage Code

## VERTICAL AIRFLOW

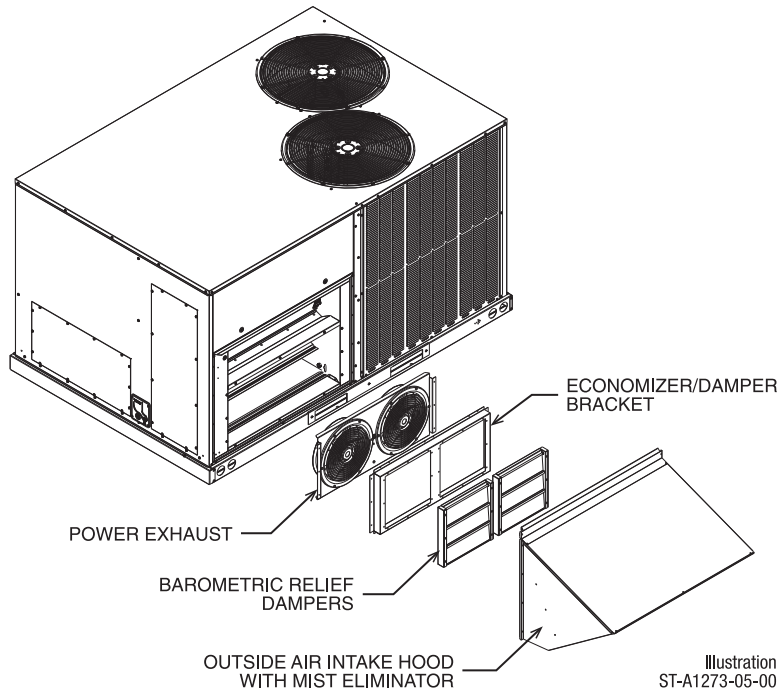

Illustration  
 ST-A1273-05-00

## HORIZONTAL AIRFLOW

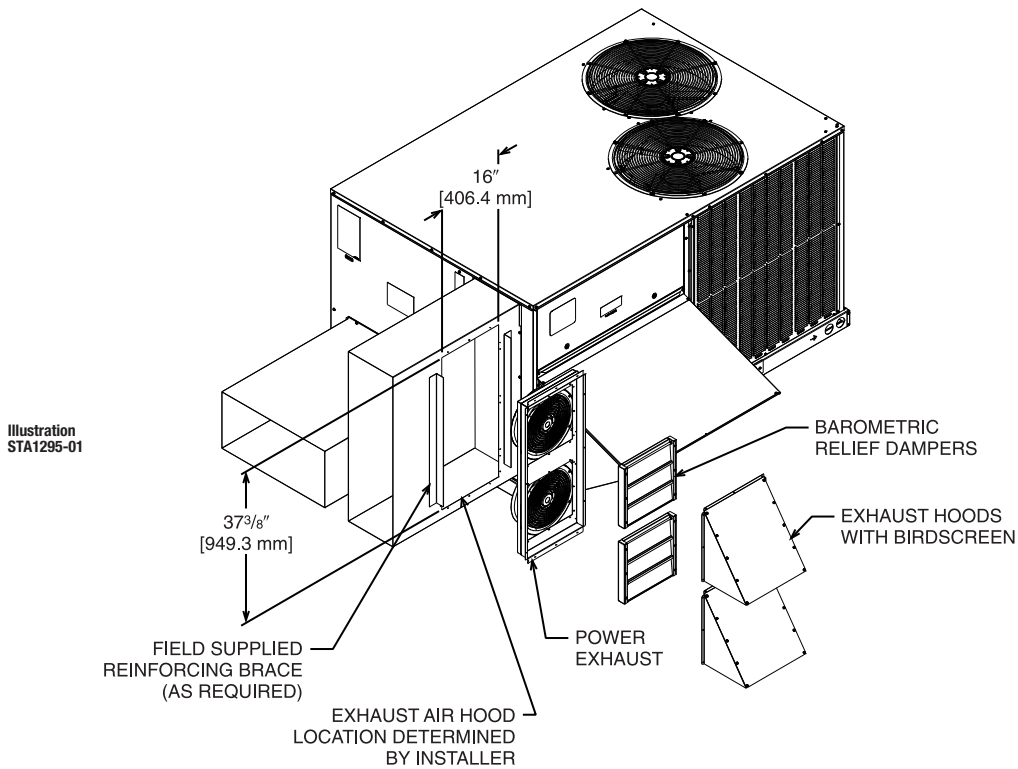

Illustration  
 STA1295-01

Model No.	No. of Fans	Volts	Phase	HP (ea.)	CFM [L/s]*	RPM	FLA (ea.)	LRA (ea.)
RXXR-CDF01C	2	208-230	1	0.47	2200	3000	1.55	1.1
RXXR-CDF01D	2	460	3	0.40	1970	2750	0.51	1.9

\*CFM is per fan at 0" w.c. external static pressure.

[ ] Designates Metric Conversions

# DDC—ECONOMIZER FOR DOWNFLOW DUCT INSTALLATION

## Use to Select Field Installed Options Only

**RXRD-01MDDBM3—Single Enthalpy (Outdoor)**  
**RXXR-BV02—Dual Enthalpy Upgrade Kit**  
**RXXR-AR02—Optional Wall-Mounted CO<sub>2</sub> Sensor**

- Features **Honeywell** Controls
- Available Factory Installed or Field Accessory
- Gear Driven Direct Drive Actuator
- Fully Modulating (0-100%)
- Ultra Low Leak Dampers meet California Title 24 requirements
- Slip-In Design for Easy Installation
- Standard Barometric Relief Damper
- Single Enthalpy with Dual Enthalpy Upgrade Kit Available
- CO<sub>2</sub> Input Sensor Available
- Field Assembled Hood Ships with Economizer
- Economizer Ships Complete for Downflow Duct Application
- Optional Remote Minimum Position Potentiometer (270 ohm) (Honeywell #S963B1136) is Available from Prostock
- Field Installed Power Exhaust Available
- Prewired for Smoke Detector
- If connected to a Building Automation System (BAS), all economizer functions can be viewed on the (BAS), or 16 x 2 LCD screen
- If connected to thermostat, all economizer functions can be viewed on 16 x 2 LCD screen

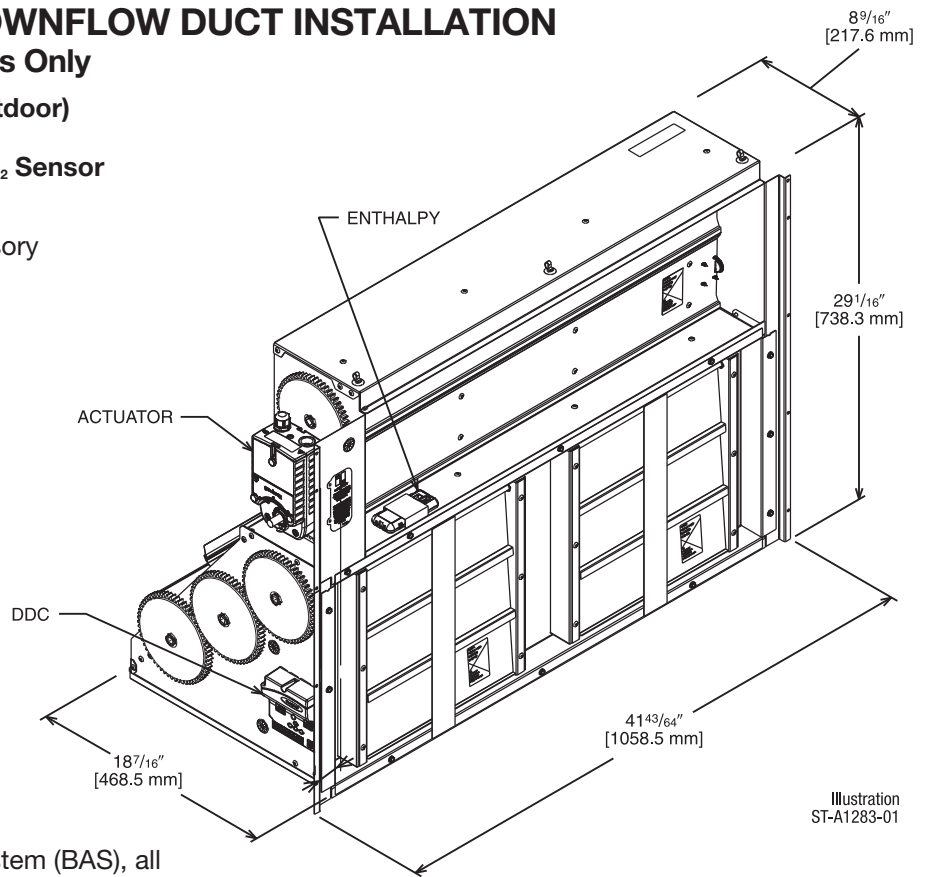

Illustration  
 ST-A1283-01

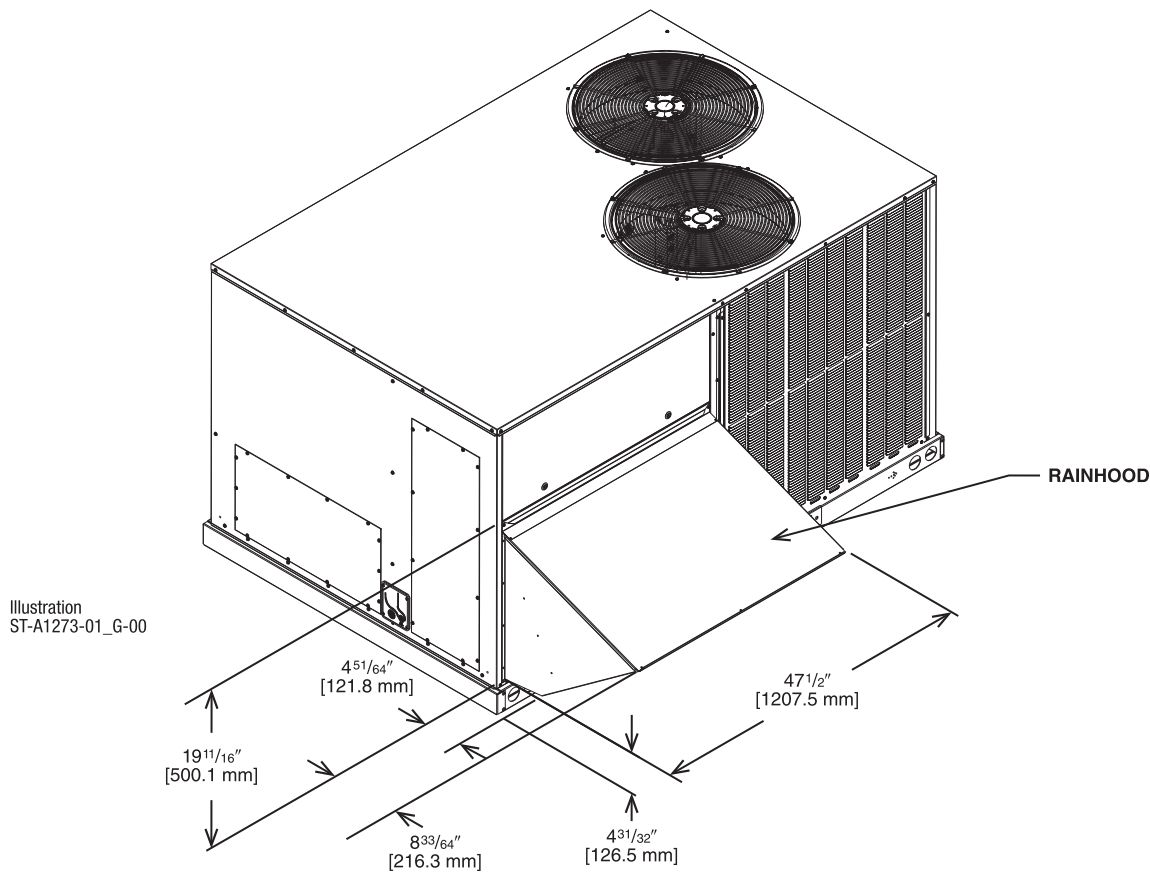

Illustration  
 ST-A1273-01\_G-00

[ ] Designates Metric Conversions



# DDC — ECONOMIZER FOR HORIZONTAL DUCT INSTALLATION

## Field Installed Only

- RXRD-01MDHBM3—Single Enthalpy (Outdoor)**
- RRRX-BV02—Dual Enthalpy Upgrade Kit**
- RRRX-AR02—Wall-mounted CO<sub>2</sub> Sensor**

- Features **Honeywell Controls**
- Available as a Field Installed Accessory Only
- Gear Driven Direct Drive Actuator
- Fully Modulating (0-100%)
- Ultra Low Leak Dampers meet California Title 24 requirements
- Slip-In Design for Easy Installation
- Standard Barometric Relief Damper
- Single Enthalpy with Dual Enthalpy Upgrade Kit Available
- CO<sub>2</sub> Input Sensor Available
- Field Assembled Hood Ships with Economizer
- Economizer Ships Complete for Horizontal Duct Application
- Optional Remote Minimum Position Potentiometer (270 ohm) (Honeywell #S963B1136) is Available from Prostock
- Field Installed Power Exhaust Available
- If connected to a Building Automation System (BAS), all economizer functions can be viewed on the (BAS), or 16 x 2 LCD screen
- If connected to thermostat, all economizer functions can be viewed on 16 x 2 LCD screen

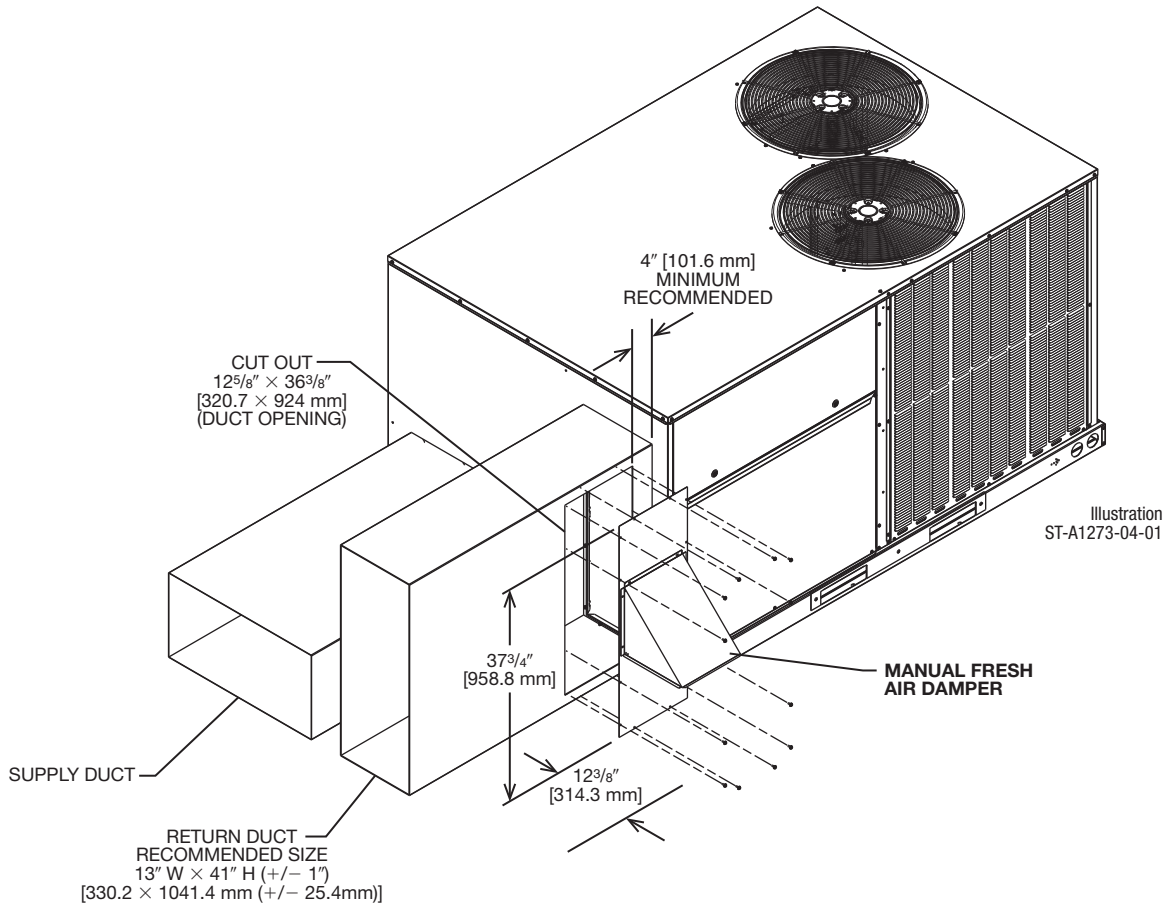
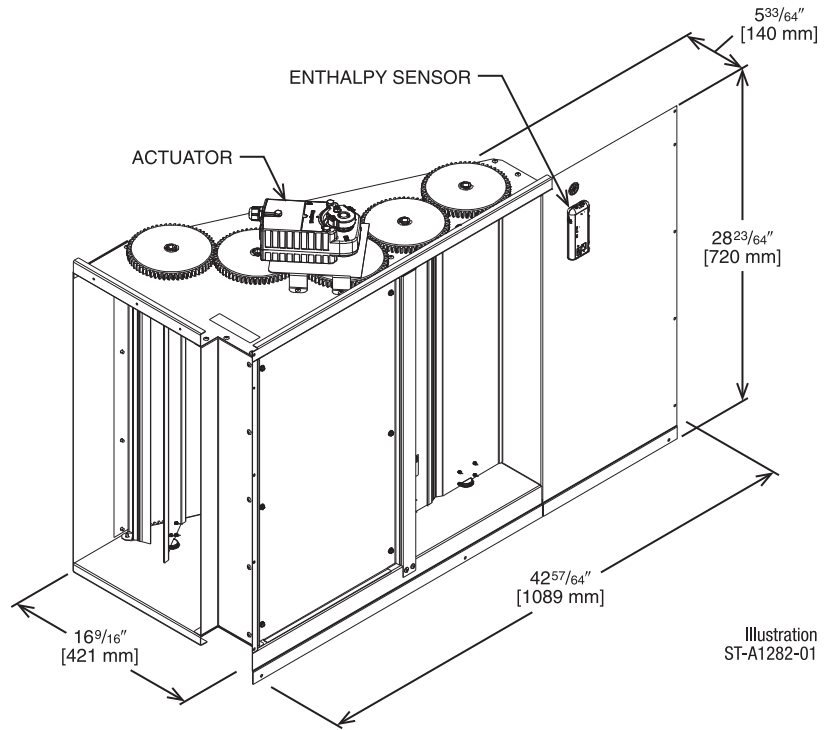

[ ] Designates Metric Conversions

## FRESH AIR DAMPER

### MOTORIZED DAMPER KIT RXRF-ADB1

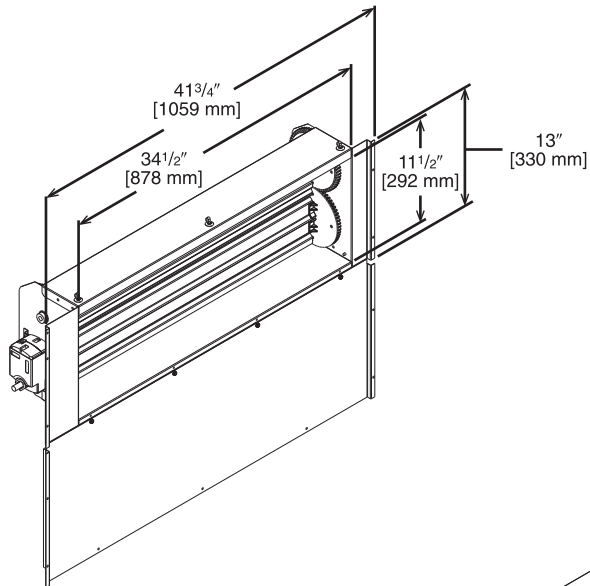

Illustration  
 ST-A1273-10-00

[ ] Designates Metric Conversions

### MOTORIZED DAMPER KIT RXRX-ADC1 (Motor Kit for DDC Models)

#### RXRX-AW04 (Modulating Motor Kit w/position feedback for AXRF-KDA1)

- Features **Honeywell** Controls
- Gear Driven Direct Drive Actuator
- Fully Modulating (0-100%)
- Low Leakage Dampers
- Slip-In Design for Easy Installation
- Plug-In Polarized 12-pin and 4-pin Electrical Connections
- Pre-Configured—No Field Adjustments Necessary
- Addition of Dual Enthalpy Upgrade Kit allows limited economizer function
- CO<sub>2</sub> Sensor Input Available for Demand Control Ventilation (DCV)
- Optional Remote Minimum Position Potentiometer (270 ohm) (Honeywell #S963B1136) is available from Prostock
- All fresh air damper functions can be viewed at the RTU-C unit controller display
- If connected to a Building Automation System (BAS), all fresh air damper functions can be viewed on the (BAS)

[ ] Designates Metric Conversions

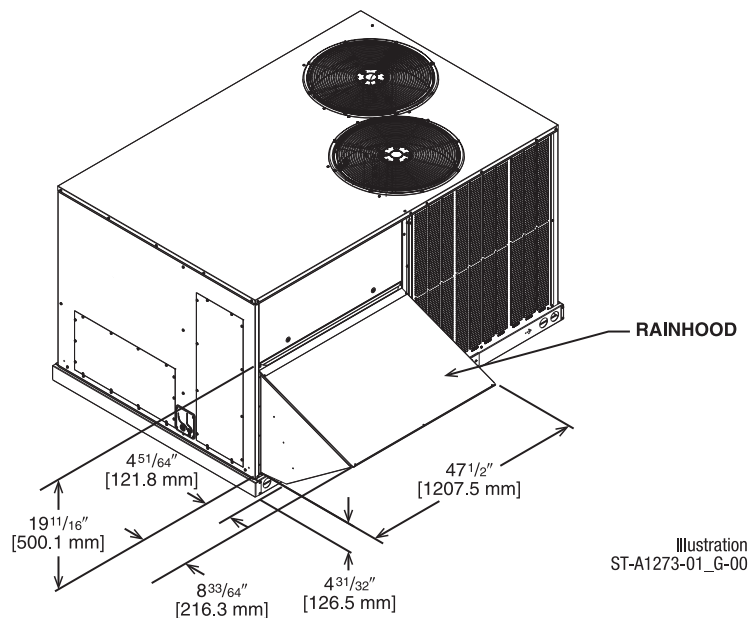

Illustration  
 ST-A1273-01\_G-00



# FRESH AIR DAMPER (Con't.)

RXRF-ADA1

## DOWNFLOW APPLICATION

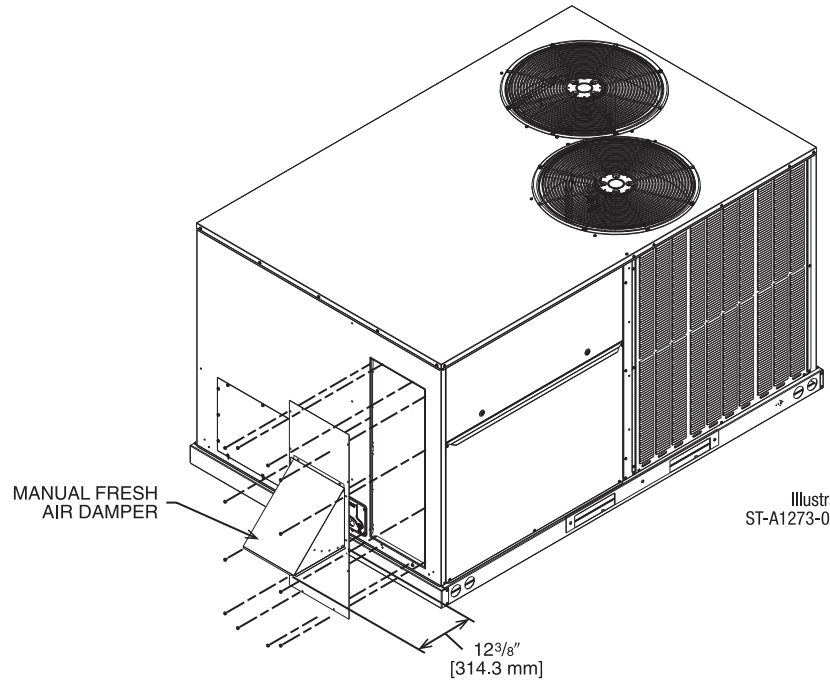

Illustration  
ST-A1273-03-00

## HORIZONTAL APPLICATION

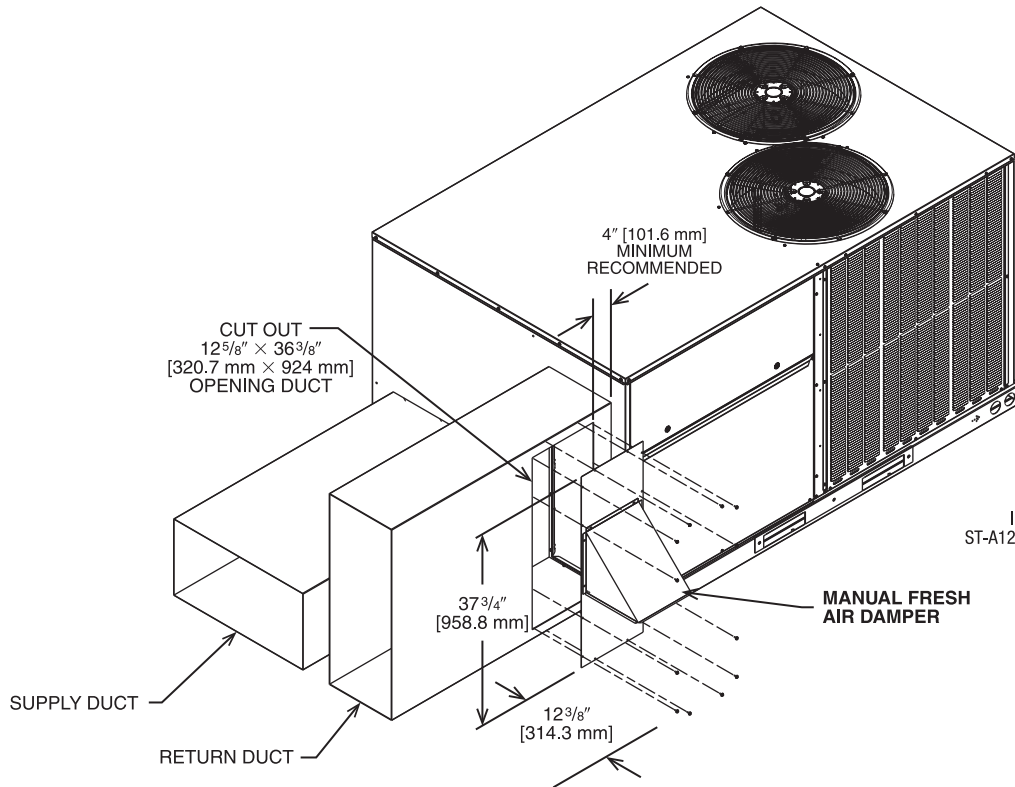
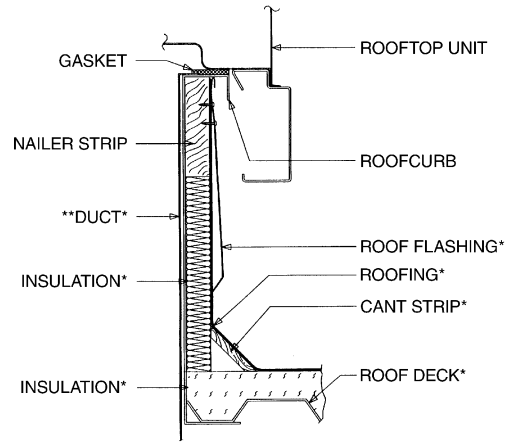

Illustration  
ST-A1273-04-00

[ ] Designates Metric Conversions

## ROOFCURBS (Full Perimeter)

- Friedrich®'s roofcurb design can be utilized on all 7.5-12.5 ton [26.4-44.0 kW] RACD.
- Two available heights (14" [356 mm] and 24" [610 mm]) for ALL models.
- Quick assembly corners for simple and fast assembly.
- Opening provided in bottom pan to match the "Thru the Curb" electrical connection opening provided on the unit base pan.
- 1" [25 mm] x 4" [102 mm] Nailer provided.
- Insulating panels not required because of insulated outdoor base pan.
- Sealing gasket (40' [12.2 m]) provided with Roofcurb.
- Packaged for easy field assembly.



\*BY CONTRACTOR  
 \*\*FOR INSTALLATION OF DUCT AS SHOWN, USE RECOMMENDED DUCT SIZES FROM ROOFCURB INSTALLATION INSTRUCTIONS. FOR DUCT FLANGE ATTACHMENT TO UNIT, SEE UNIT INSTALLATION INSTRUCTIONS FOR RECOMMENDED DUCT SIZES.

Illustration  
 ST-A0743-02

View	Roofcurb Model	Height of Curb
A	RXKG-DDD14	14" [356 mm]
A	RXKG-DDD24	24" [610 mm]

## ROOFCURB INSTALLATION

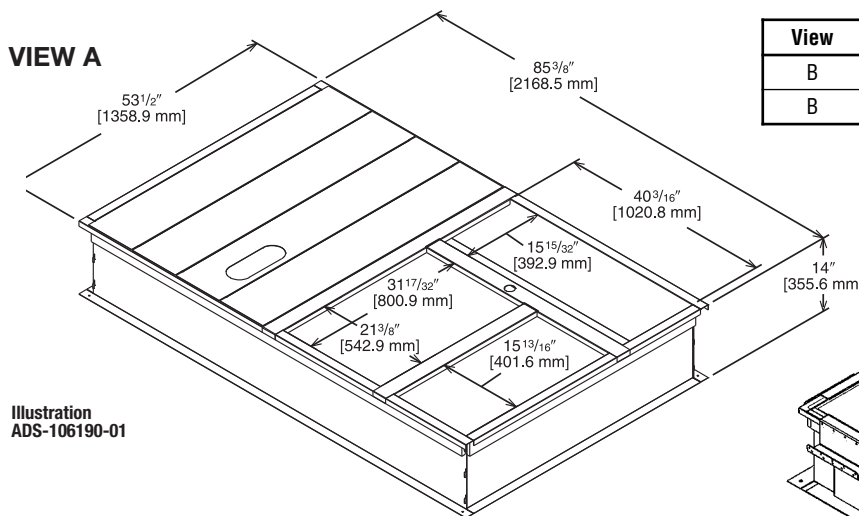
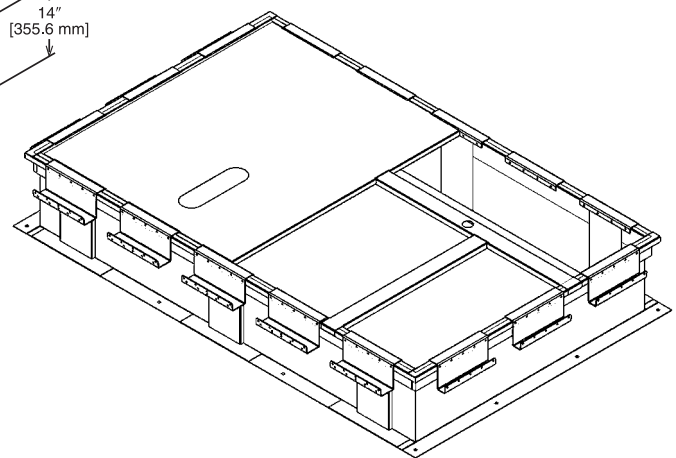

Illustration  
 ADS-106190-01

View	Roofcurb Model	Dimensions
B	RXKG-SD14	85.375" x 53.5" x 14.0"
B	RXKG-SD24	85.375" x 53.5" x 24.0"

## WELDED ROOFCURB VIEW B



- State of Florida Approved: Approval Number FL 26981.1 for Technical Evaluation Report TER-20-28788 certifies the HVAC Unit and mounting methods for high wind resistance are compliant per Florida Building Code.
- OSHPD Approved: State of California Product Approval Number OSP-06660-TEMPO0 for Technical Evaluation Report 1700876-CR-001-RO certifies the HVAC Unit and Mircrometl Welded Roof Curb is earthquake resistance compliant and approved for use per International Code Council – Evaluation Service AC156, IBC, AND CBC building code standards.

[ ] Designates Metric Conversions

# ROOFCURB ADAPTERS (Con't.)

**RXRX-DDCAE**

Illustration  
 ADS-106176-01  
 SHEET 2

## APPROXIMATE STATIC PRESSURE DROP

@2,000 = 0.06" w.g.
@3,000 = 0.12" w.g.
@4,000 = 0.22" w.g.
@5,000 = 0.36" w.g.

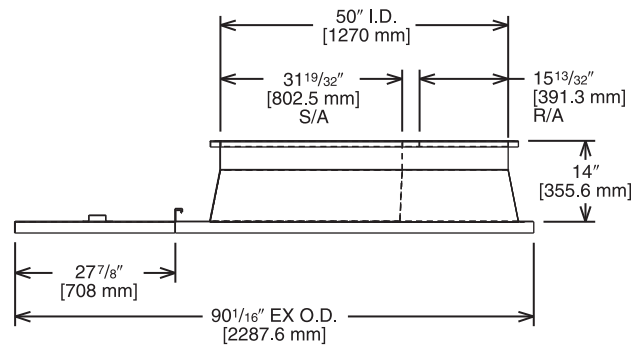
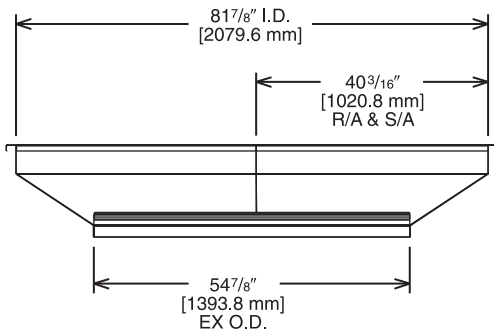
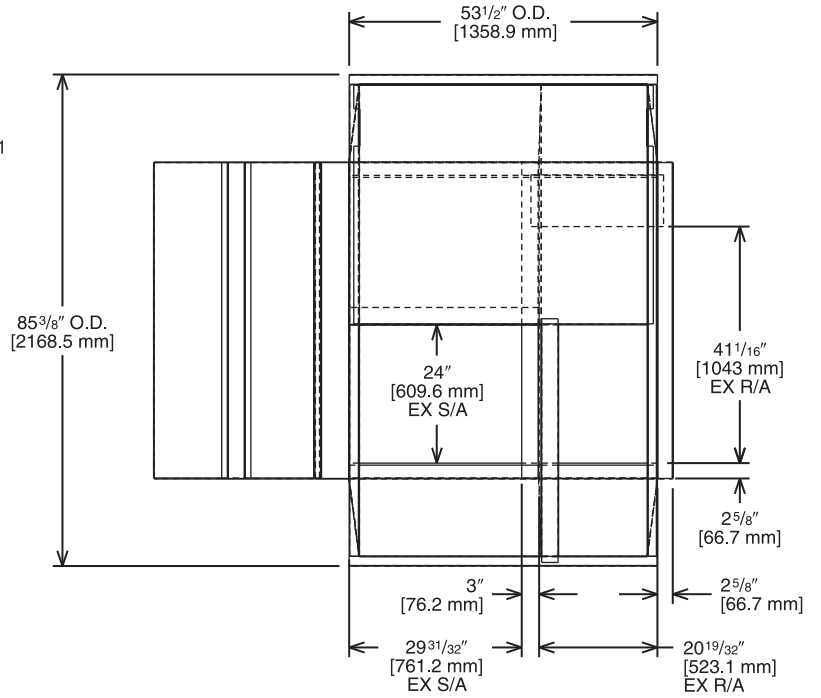

## TOP VIEW

Illustration  
 ADS-106176-01  
 SHEET 1

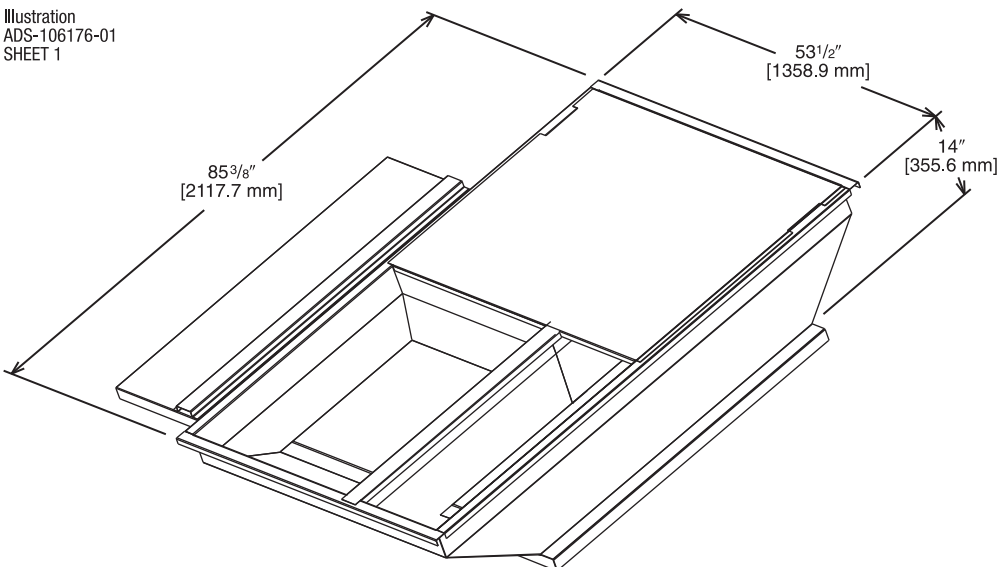

[ ] Designates Metric Conversions

## CONCENTRIC DIFFUSER APPLICATION

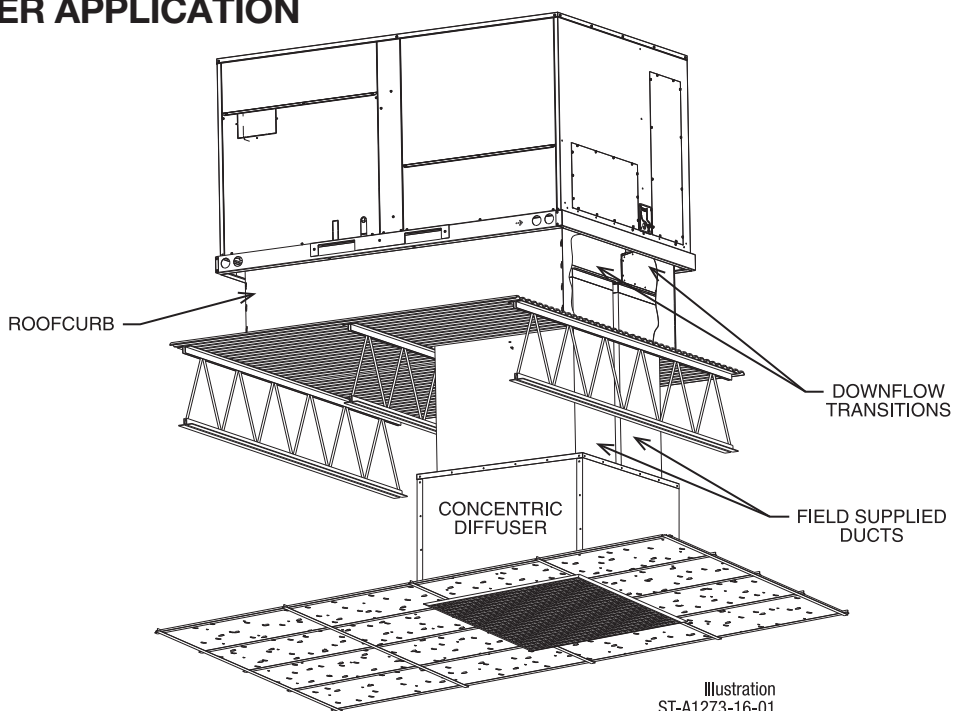

## DOWNFLOW TRANSITION DRAWINGS

### RXMC-DD02

- Used with RXRN-AEF3415 or RXRN-AED3415 Concentric Diffusers

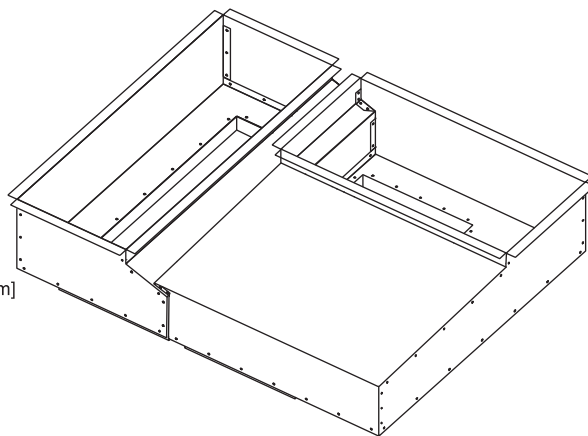
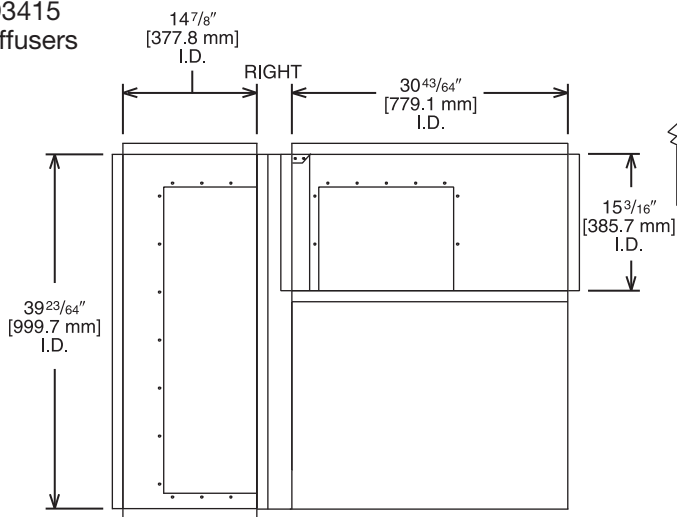
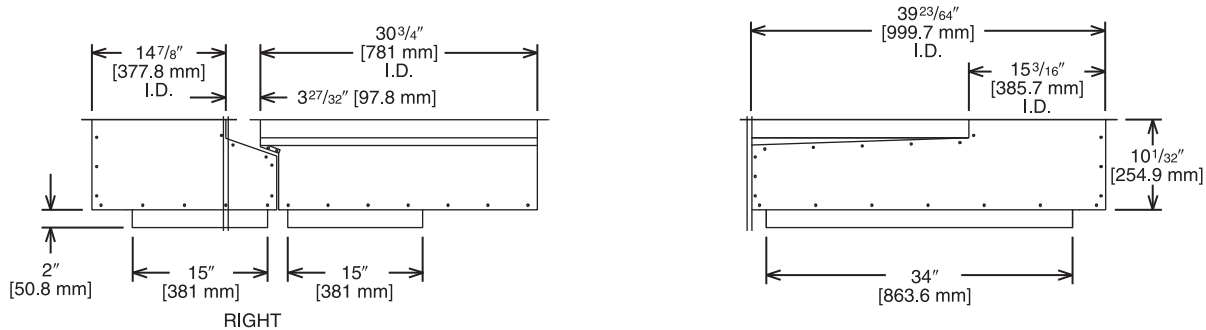

Illustration  
 ADS-106193-02



[ ] Designates Metric Conversions

## DOWNFLOW TRANSITION DRAWINGS (Con't.)

### RXMC-DD03

- Used with RXRN-AEF3618  
 or RXRN-AED3618  
 Concentric Diffusers

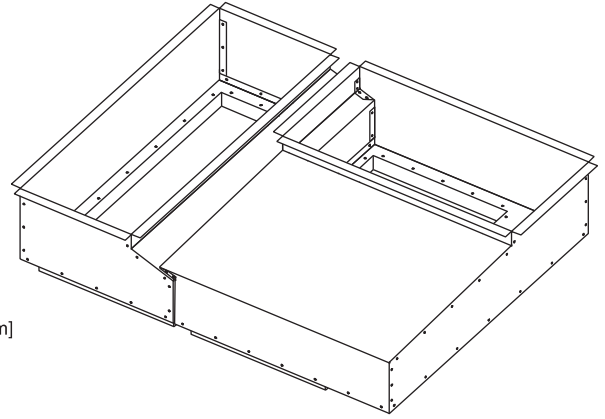
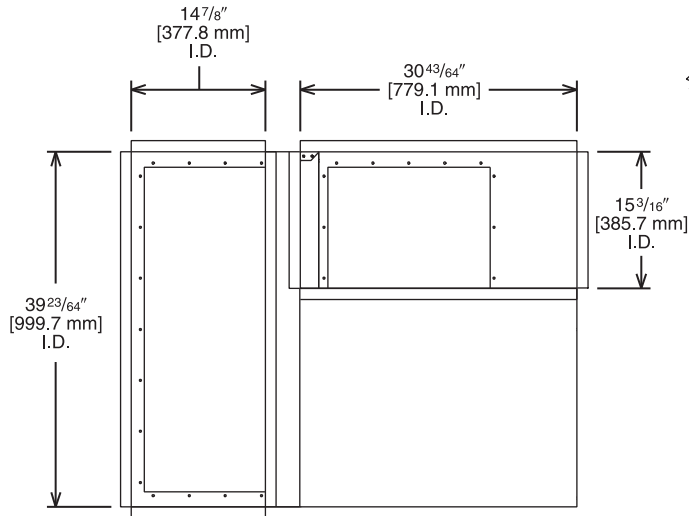
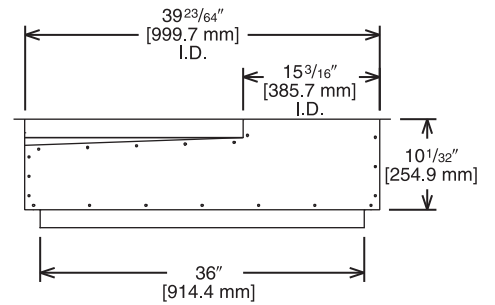
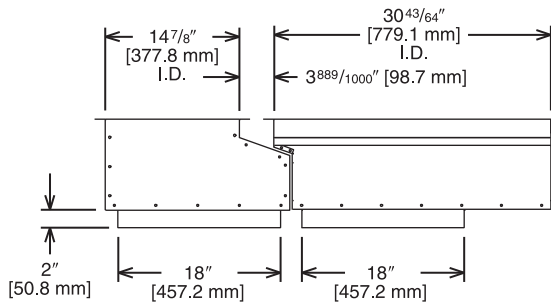

Illustration  
 ADS-106193-03



[ ] Designates Metric Conversions

## DOWNFLOW TRANSITION DRAWINGS (Con't.)

### RXMC-DD01

- Used with RXRN-AEF2000  
or RXRN-AED2000  
Concentric Diffusers

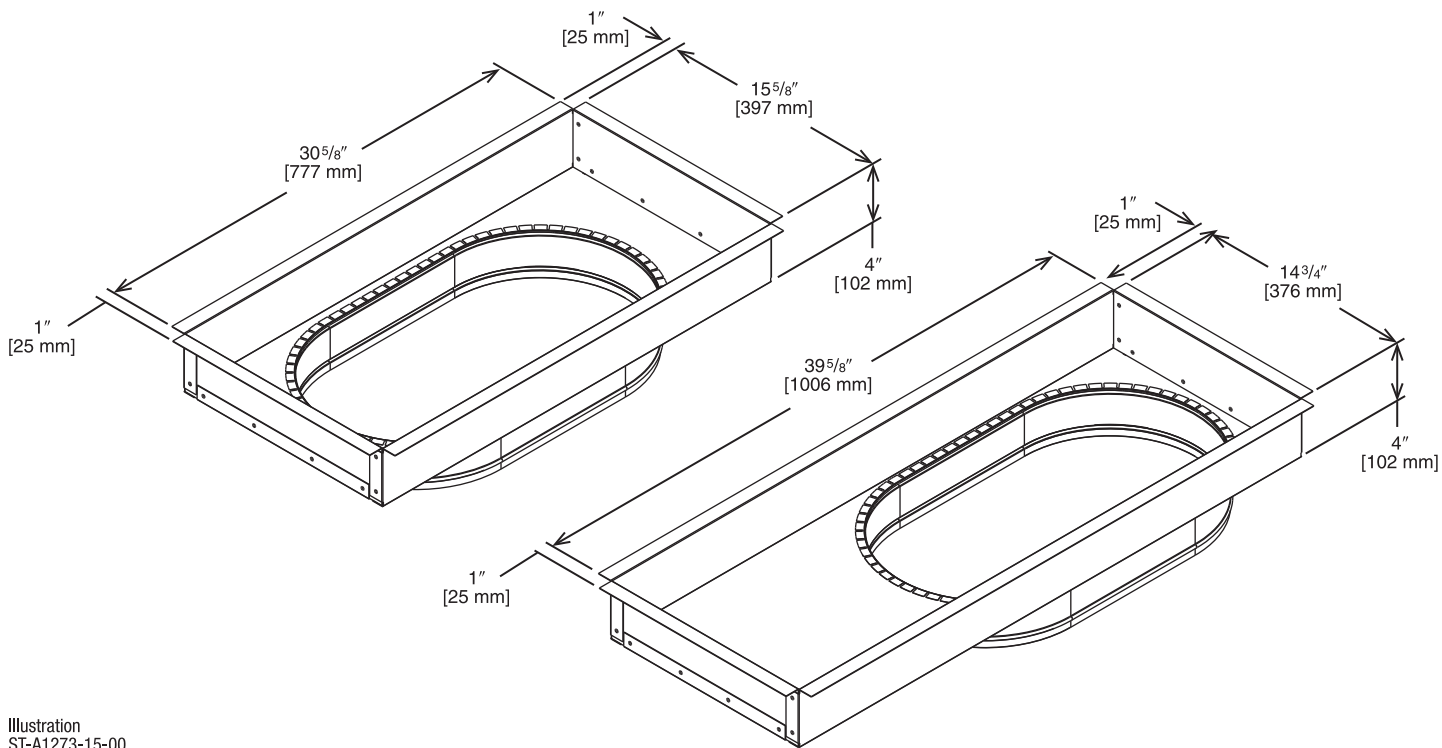

Illustration  
ST-A1273-15-00

[ ] Designates Metric Conversions

## CONCENTRIC DIFFUSER—STEP DOWN

RXRN-AED2000 (7.5 & 8.5 Ton [26.4 & 29.9 kW] Models)

For Use With Downflow Transition (RXMC-DD01)  
 and 20" [508 mm] Round Supply and Return Ducts

- All aluminum diffuser with aluminum return air eggcrate.
- Built-in anti-sweat gasket.
- Molded fiberglass supports.
- Built-in hanging supports.
- Diffuser box constructed of sheetmetal insulated with 1" [25.4 mm] 1.5 lbs. [.7 kg] duct liner.

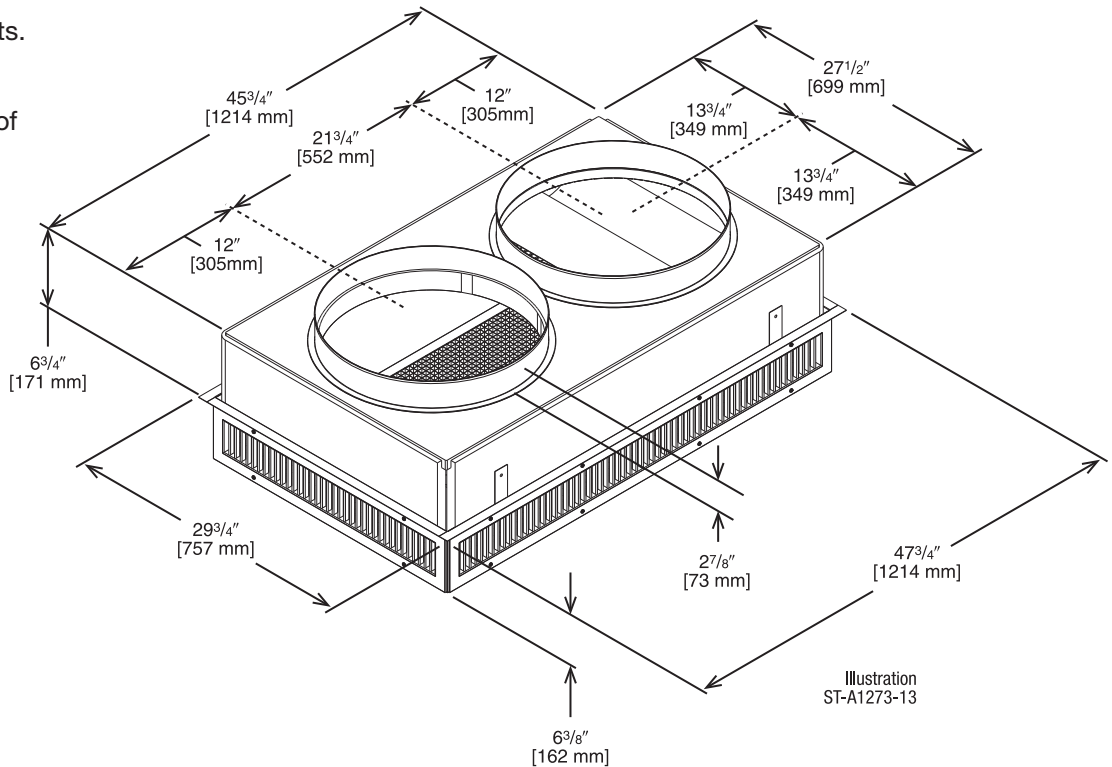

### ENGINEERING DATA<sup>①</sup>

Model No.	Flow Rate CFM [L/s]	Throw <sup>② ③</sup> Feet [m]	Neck Velocity fpm [m/s]	Noise Level <sup>④</sup> (dbA)
RXRN-AED2000	2600 [1222]	22-39 [6.7-11.9]	669 [3.4]	32
	2800 [1316]	23-40 [7.1-12.2]	720 [3.7]	38
	3000 [1410]	25-42 [7.6-12.8]	772 [3.9]	40
	3200 [1504]	26-43 [7.9-13.1]	823 [4.2]	41
	3400 [1598]	27-45 [8.2-13.7]	874 [4.4]	42
	3600 [1692]	30-50 [9.1-15.2]	925.5 [4.7]	45
	3800 [1786]	32-53 [9.8-16.2]	976.8 [4.9]	48
	4000 [1880]	34-56 [10.4-17.1]	1028.1 [5.2]	50

- NOTES:** ① All data is based on the air diffusion council guidelines.  
 ② Throw data is based on 75 FPM Terminal Velocities using isothermal air.  
 ③ Throw is based on diffuser blades being directed in a straight pattern.  
 ④ Actual noise levels may vary due to duct design and do not include transmitted unit noise.  
 Adequate duct attenuation must be provided to reduce sound output from the unit.

[ ] Designates Metric Conversions



## CONCENTRIC DIFFUSER – STEP DOWN 15" x 34" [381 x 836 mm]

RXRN-AED3415 (8.5 & 10 Ton [29.9 kW & 35.2] Models)

For Use With Downflow Transition (RXMC-DD02)  
and 15" x 34" [381 x 836 mm]  
Supply and Return Ducts

- All aluminum diffuser with aluminum return air eggcrate.
- Built-in anti-sweat gasket.
- Molded fiberglass supports.
- Built-in hanging supports.
- Diffuser box constructed of sheetmetal insulated with 1" [25.4 mm] 1.5 lbs. [.7 kg] duct liner.
- Double deflection diffuser with the blades secured by spring steel.

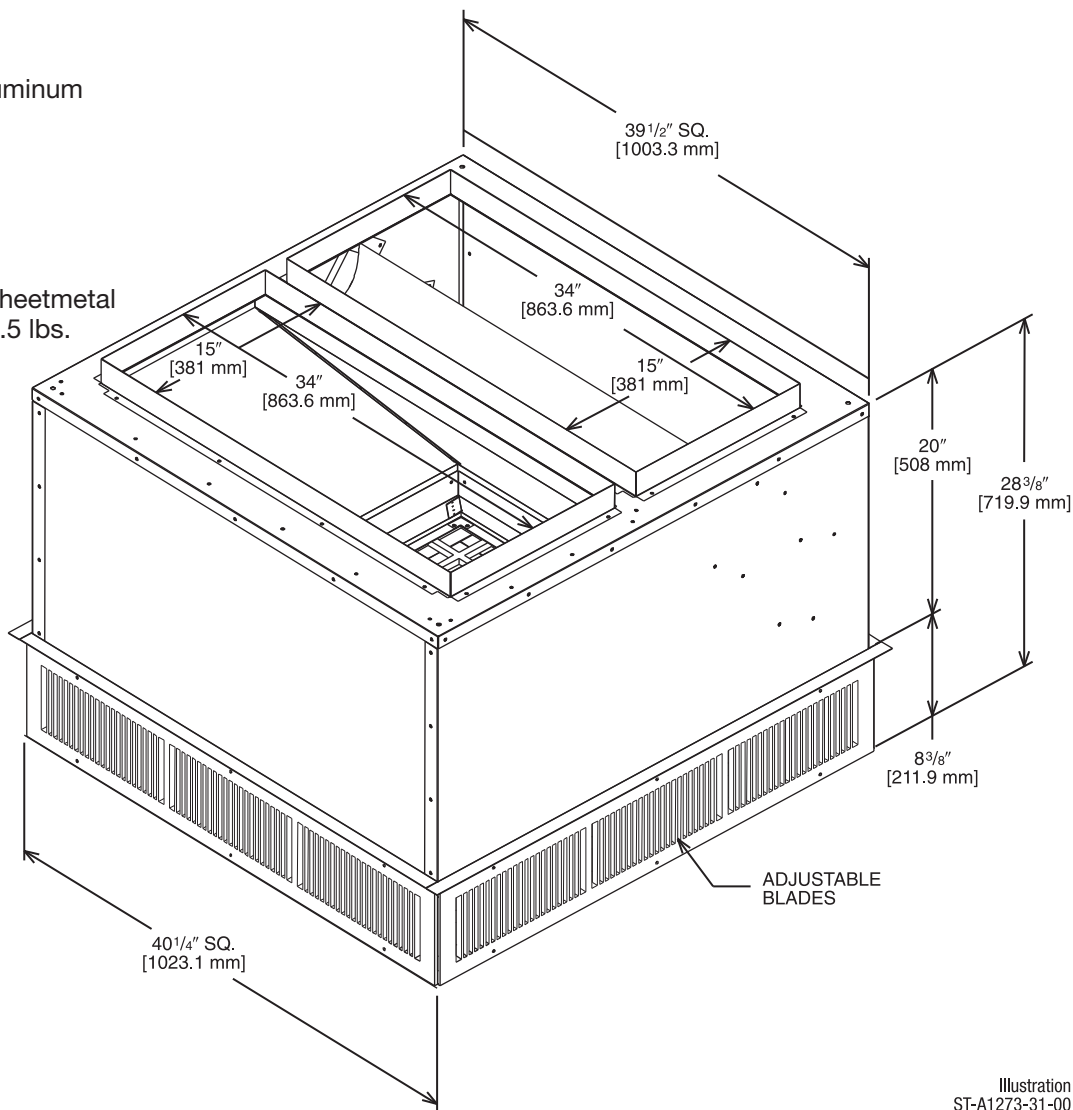

Illustration  
ST-A1273-31-00

### ENGINEERING DATA<sup>①</sup>

Model No.	Flow Rate CFM [L/s]	Throw <sup>② ③</sup> Feet [m]	Neck Velocity fpm [m/s]	Noise Level <sup>④</sup> (dba)
RXRN-AED3415	3600 [1692]	26-53 [7.9-16.2]	851 [4.3]	27
	3800 [1786]	27-55 [8.2-16.8]	898 [4.5]	29
	4000 [1880]	29-58 [8.8-17.7]	946 [4.8]	30
	4200 [1974]	31-61 [9.4-18.6]	993 [5.1]	32
	4400 [2068]	32-64 [9.8-19.5]	1040 [5.3]	33
	4600 [2162]	34-66 [10.4-20.1]	1087.5 [5.5]	35

- NOTES: ① All data is based on the air diffusion council guidelines.  
 ② Throw data is based on 75 FPM Terminal Velocities using isothermal air.  
 ③ Throw is based on diffuser blades being directed in a straight pattern.  
 ④ Actual noise levels may vary due to duct design and do not include transmitted unit noise.  
 Adequate duct attenuation must be provided to reduce sound output from the unit.

[ ] Designates Metric Conversions

# CONCENTRIC DIFFUSER—STEP DOWN 18" x 36" [457 x 914 mm]

**RXRN-AED3618 (12.5 & 15 Ton [44.0 & 52.8 kW] Models)**

**For Use With Downflow Transition (RXMC-DD03)  
 and 18" x 36" [457 x 914 mm]  
 Supply and Return Ducts**

- All aluminum diffuser with aluminum return air eggcrate.
- Built-in anti-sweat gasket.
- Molded fiberglass supports.
- Built-in hanging supports.
- Diffuser box constructed of sheetmetal insulated with 1" [25.4 mm] 1.5 lbs. [.7 kg] duct liner.
- Double deflection diffuser with the blades secured by spring steel.

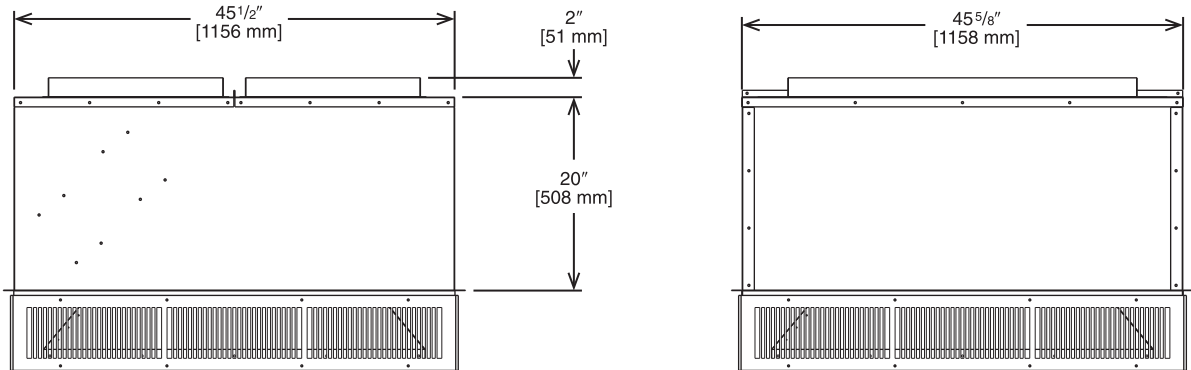
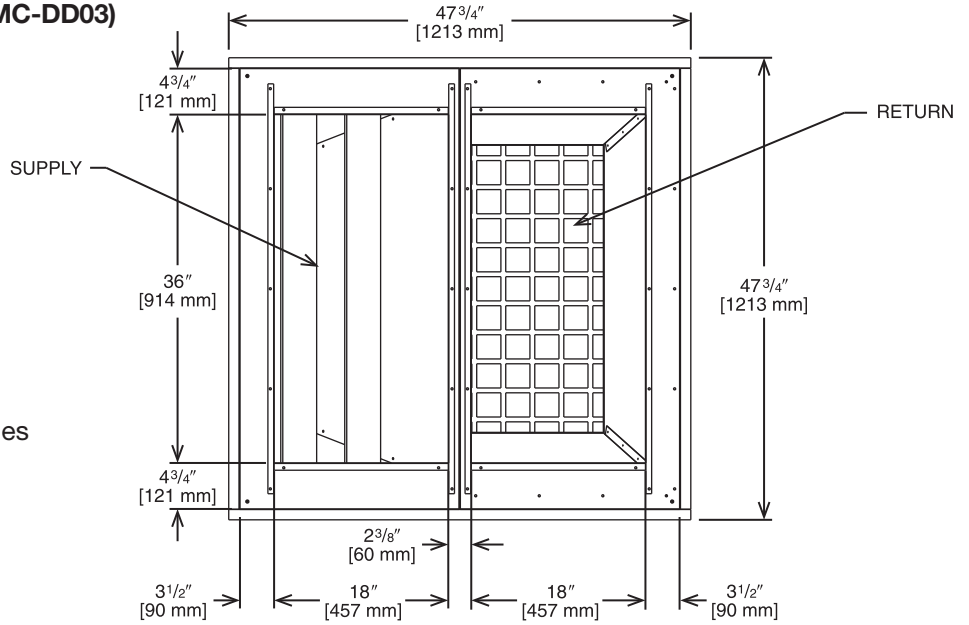

Illustration  
 ST-A1273-11-00

## ENGINEERING DATA<sup>①</sup>

Model No.	Flow Rate CFM [L/s]	Throw <sup>② ③</sup> Feet [m]	Neck Velocity fpm [m/s]	Noise Level <sup>④</sup> (dbA)
RXRN-AED3618	4400 [2068]	29-55 [8.8-16.8]	841 [4.3]	26
	4600 [2162]	31-57 [9.4-17.4]	875 [4.4]	28
	4800 [2256]	32-60 [9.8-18.3]	915 [4.6]	29
	5000 [2350]	33-62 [10.1-18.9]	951 [4.8]	30
	5200 [2444]	34-65 [10.4-19.8]	988 [5.1]	31
	5400 [2538]	36-67 [10.9-20.4]	1025 [5.2]	32

- NOTES:** ① All data is based on the air diffusion council guidelines.  
 ② Throw data is based on 75 FPM Terminal Velocities using isothermal air.  
 ③ Throw is based on diffuser blades being directed in a straight pattern.  
 ④ Actual noise levels may vary due to duct design and do not include transmitted unit noise. Adequate duct attenuation must be provided to reduce sound output from the unit.

[ ] Designates Metric Conversions

# FLUSH MOUNT CONCENTRIC DIFFUSER—FLUSH

RXRX-AEF2000 (7.5 & 8.5 Ton [26.4 & 29.9 kW] Models)

For Use With Downflow Transition (RXMC-DD01)  
 20" [508 mm] Round Supply and Return Ducts

- All aluminum diffuser with aluminum return air eggcrate.
- Built-in anti-sweat gasket.
- Molded fiberglass supports.
- Built-in hanging supports.
- Diffuser box constructed of sheetmetal insulated with 1" [25.4 mm] 1.5 lbs. [.7 kg] duct liner.

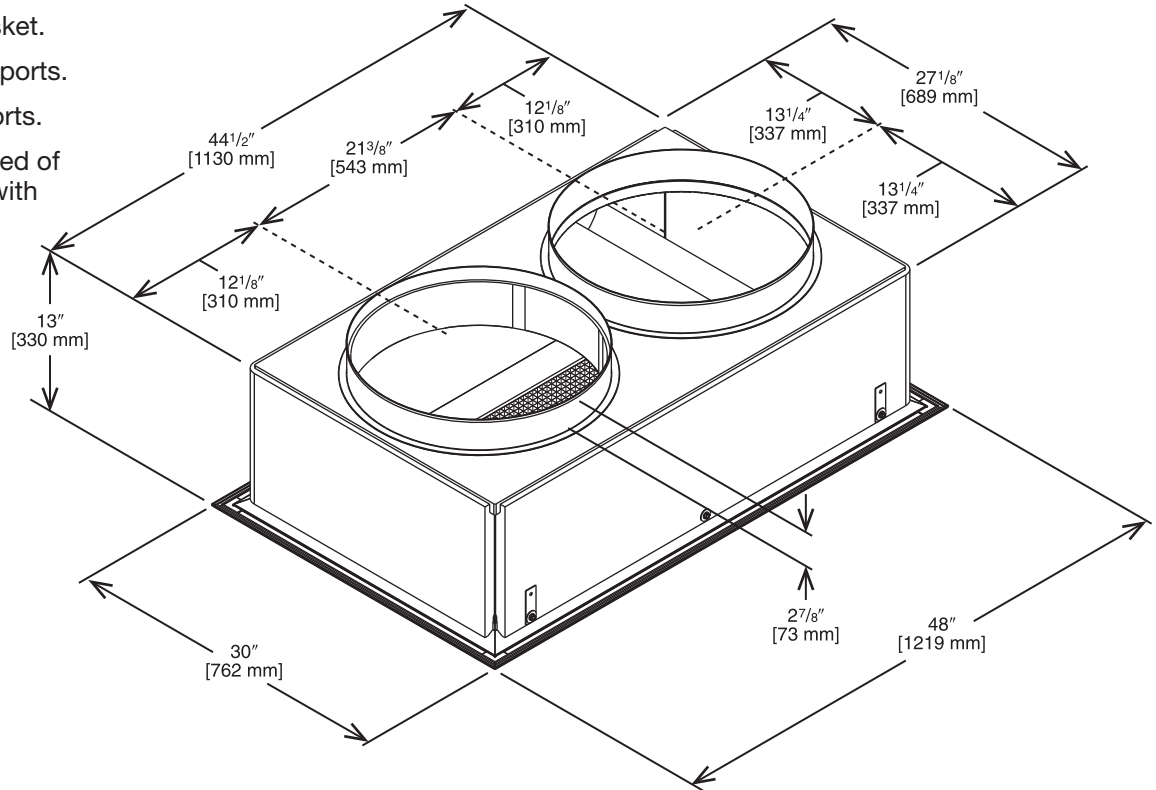

Illustration  
 ST-A1273-14-00

## ENGINEERING DATA<sup>①</sup>

Model No.	Flow Rate CFM [L/s]	Throw <sup>②</sup> <sup>③</sup> Feet [m]	Neck Velocity fpm [m/s]	Noise Level <sup>④</sup> (dbA)
RXRN-AEF2000	2600 [1222]	17-24 [5.2-7.3]	663 [3.4]	30
	2800 [1316]	18-28 [5.5-8.5]	714 [3.6]	35
	3000 [1410]	20-30 [6.1-9.1]	765 [3.9]	35
	3200 [1504]	22-33 [6.7-10.1]	816 [4.1]	40
	3400 [1598]	23-37 [7-11.3]	867 [4.4]	40
	3600 [1692]	25-38 [7.6-11.6]	918 [4.7]	43
	3800 [1786]	26-39 [7.9-11.9]	969 [4.9]	45
	4000 [1880]	27-40 [8.2-12.2]	1020 [5.2]	48

- NOTES: <sup>①</sup> All data is based on the air diffusion council guidelines.  
<sup>②</sup> Throw data is based on 75 FPM Terminal Velocities using isothermal air.  
<sup>③</sup> Throw is based on diffuser blades being directed in a straight pattern.  
<sup>④</sup> Actual noise levels may vary due to duct design and do not include transmitted unit noise.  
 Adequate duct attenuation must be provided to reduce sound output from the unit.

[ ] Designates Metric Conversions

# CONCENTRIC DIFFUSER—FLUSH 15" x 34" [381 x 864 mm]

RXRN-AEF3415 (8.5 & 10 Ton [29.9 & 35.2] Models)

For Use With Downflow Transition (RXMC-DD02)  
 15" x 34" [381 x 864 mm]  
 Supply and Return Ducts

- All aluminum diffuser with aluminum return air eggcrate.
- Built-in anti-sweat gasket.
- Molded fiberglass supports.
- Built-in hanging supports.
- Diffuser box constructed of sheetmetal insulated with 1" [25.4 mm] 1.5 lbs. [.7 kg] duct liner.

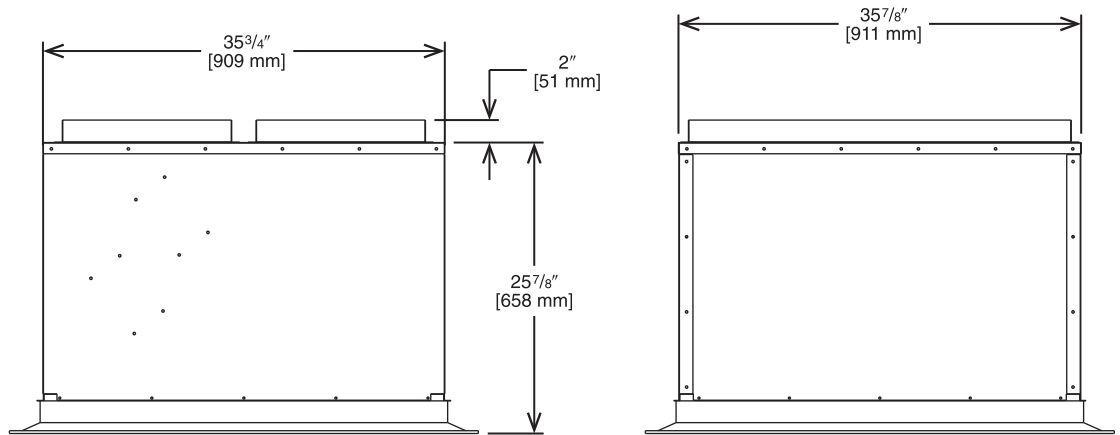
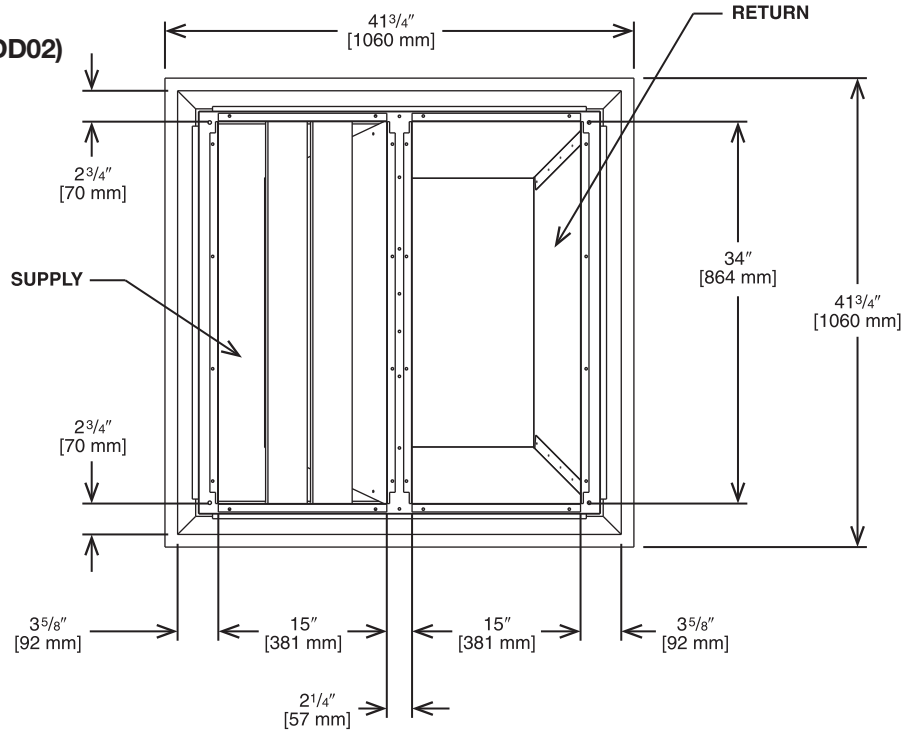

Illustration  
 ST-A1273-07-00

## ENGINEERING DATA<sup>①</sup>

Model No.	Flow Rate CFM [L/s]	Throw <sup>② ③</sup> Feet [m]	Neck Velocity fpm [m/s]	Noise Level <sup>④</sup> (dbA)
RXRN-AEF3415	3600 [1692]	14-34 [4.3-10.4]	844 [4.3]	27
	3800 [1786]	15-36 [4.6-11.1]	891 [4.5]	29
	4000 [1880]	16-37 [4.9-11.3]	938 [4.8]	30
	4200 [1974]	17-39 [5.2-11.9]	985 [5.1]	32
	4400 [2068]	18-41 [5.5-12.5]	1032 [5.2]	33
	4600 [2162]	19-43 [5.8-13.1]	1079 [5.5]	35
	4800 [2256]	20-45 [6.1-13.7]	1126 [5.7]	36

- NOTES: ① All data is based on the air diffusion council guidelines.  
 ② Throw data is based on 75 FPM Terminal Velocities using isothermal air.  
 ③ Throw is based on diffuser blades being directed in a straight pattern.  
 ④ Actual noise levels may vary due to duct design and do not include transmitted unit noise. Adequate duct attenuation must be provided to reduce sound output from the unit.

[ ] Designates Metric Conversions

# CONCENTRIC DIFFUSER – FLUSH

## 18" x 36" [457 x 914 mm]

RXRN-AEF3618 (12.5 Ton [44.0 kW] Models)

For Use With Downflow Transition (RXMC-DD03)  
 and 18" x 36" [457 x 914 mm]  
 Supply and Return Ducts

- All aluminum diffuser with aluminum return air eggcrate.
- Built-in anti-sweat gasket.
- Molded fiberglass supports.
- Built-in hanging supports.
- Diffuser box constructed of sheetmetal insulated with 1" [25.4 mm] 1.5 lbs. [.7 kg] duct liner.

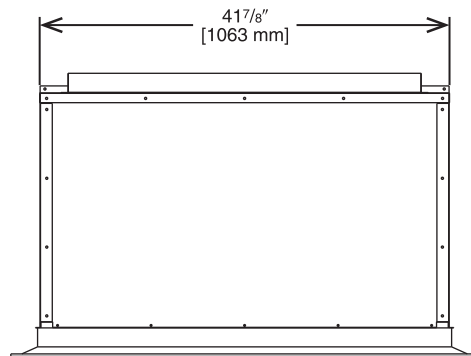
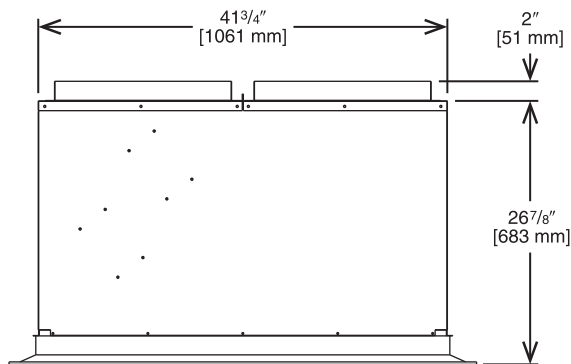
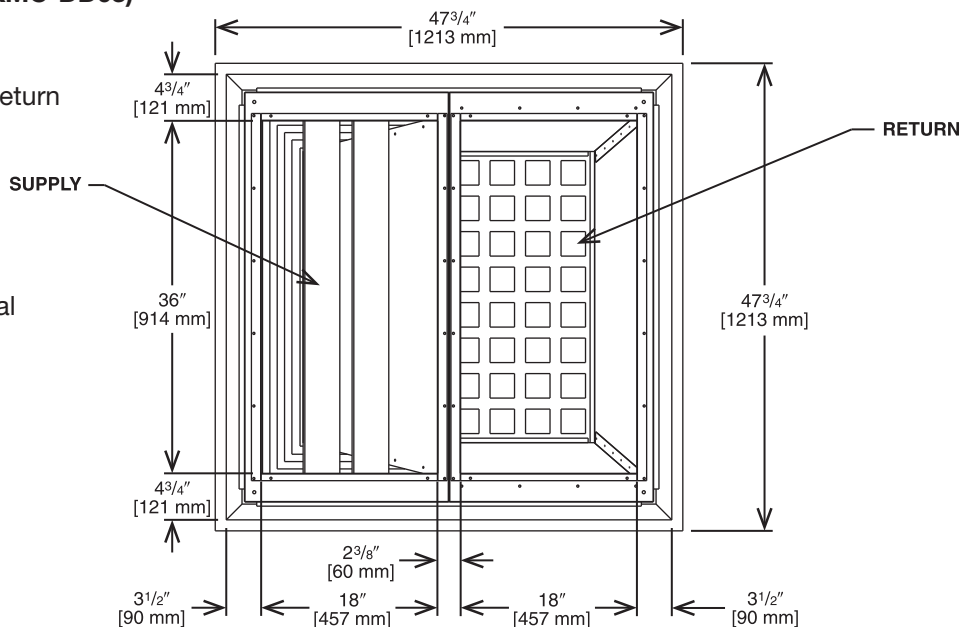

Illustration  
 ST-A1273-12-00

## ENGINEERING DATA<sup>①</sup>

Model No.	Flow Rate CFM [L/s]	Throw <sup>② ③</sup> Feet [m]	Neck Velocity fpm [m/s]	Noise Level <sup>④</sup> (dba)
RXRN-AEF3618	4400 [2068]	13-28 [4.1-8.5]	922 [47]	35
	4600 [2162]	14-30 [4.3-9.1]	962 [4.9]	37
	4800 [2256]	15-31 [4.6-9.4]	1002 [5.1]	39
	5000 [2350]	16-32 [4.9-9.8]	1043 [5.3]	40
	5200 [2444]	17-33 [5.2-10.1]	1083 [5.5]	42
	5400 [2538]	18-35 [5.5-10.7]	1123 [5.7]	43

- NOTES: ① All data is based on the air diffusion council guidelines.  
 ② Throw data is based on 75 FPM Terminal Velocities using isothermal air.  
 ③ Throw is based on diffuser blades being directed in a straight pattern.  
 ④ Actual noise levels may vary due to duct design and do not include transmitted unit noise. Adequate duct attenuation must be provided to reduce sound output from the unit.

[ ] Designates Metric Conversions

## Guide Specifications RGED – 090-150

You may copy this document directly into your building specification. This specification is written to comply with the 2016 version of the “master format” as published by the Construction Specification Institute. [www.csinet.org](http://www.csinet.org).

### GAS HEAT PACKAGED ROOFTOP

#### HVAC Guide Specifications

#### Size Range: 7<sup>1</sup>/<sub>2</sub> to 12<sup>1</sup>/<sub>2</sub> Nominal Tons

Section	Description
---------	-------------

<b>23 06 80</b>	<b>Schedules for Decentralized HVAC Equipment</b>
-----------------	---

<b>23 06 80.13</b>	<b>Decentralized Unitary HVAC Equipment Schedule</b>
--------------------	--

23 06 80.13.A.	Rooftop unit schedule
----------------	-----------------------

1. Schedule is per the project specification requirements.

<b>23 07 16</b>	<b>HVAC Equipment Insulation</b>
-----------------	----------------------------------

23 07 16.00.A.	Evaporator fan compartment:
----------------	-----------------------------

1. Interior cabinet surfaces shall be insulated with a minimum 1/2-in. thick, minimum 1.6 LB density, flexible fiberglass insulation bonded with foil face on the air side.
2. Insulation and adhesive shall meet NFPA 90A requirements for flame spread and smoke generation.
3. Insulation shall also be mechanically fastened with welded pin and retainer washer.

23 07 16.00.B.	Gas heat compartment:
----------------	-----------------------

1. Aluminum foil-faced fiberglass insulation shall be used.
2. Insulation and adhesive shall meet NFPA 90A requirements for flame spread and smoke generation.
3. Insulation shall also be mechanically fastened with welded pin and retainer washer.

<b>23 09 13</b>	<b>Instrumentation and Control Devices for HVAC</b>
-----------------	---

<b>23 09 13.23</b>	<b>Sensors and Transmitters:</b>
--------------------	----------------------------------

23 09 13.23.A.	Thermostats
----------------	-------------

1. Thermostat must
  - a. energize both “W” and “G” when calling for heat.
  - b. have capability to energize 2 different stages of cooling, and 2 different stages of heating.
  - c. must include capability for occupancy scheduling.

<b>23 09 33</b>	<b>Direct-Digital Control System for HVAC</b>
-----------------	---

23 09 33.00.A.	RTU-C controller
----------------	------------------

1. Shall be ASHRAE 62-2001 compliant.
2. Shall accept 18-32VAC input power.
3. Shall have an operating temperature range from -40°F (-40°C) to 158°F (70°C), 10%–95% RH (non-condensing).
4. Controller shall accept the following inputs: space temperature, setpoint adjustment, outdoor air temperature, indoor air quality, outdoor air enthalpy, fire shutdown, return air enthalpy, fan status, remote time clock/door switch.
5. Shall accept a CO<sub>2</sub> sensor in the conditioned space, and be Demand Control Ventilation (DCV) ready.
6. Shall provide the following outputs: Economizer, fan, cooling stage 1, cooling stage 2, heat stage 1, heat stage 2, exhaust, occupied.
7. Unit shall provide surge protection for the controller through a circuit breaker.
8. Shall have a field installed communication card allowing the unit to be able to communicate at a Baud rate of 19.2K or faster.
9. Shall have an LED display independently showing the status of activity on the communication bus, and processor operation.
10. Optional field installed BACnet® plug-in communication card which includes an EIA-485 protocol communication port, or an optional field installed LonWorks™ plug-in communications card.
11. Software upgrades will be accomplished by local download. Software upgrades through chip replacements are not allowed.
12. Shall be shock resistant in all planes to 5G peak, 11ms during operation, and 100G peak, 11ms during storage.
13. Shall be vibration resistant in all planes to 1.5G @ 20-300 Hz.
14. Shall support a bus length of 4000 ft max, 60 devices per 1000 ft section, and 1 RS-485 repeater per 1000 ft sections.

24 09 33.00.B.	Open protocol, direct digital controller:
----------------	---

1. Shall be ASHRAE 62-2001 compliant.
2. Shall accept 18-30VAC, 50-60Hz, and consumer 15VA or less power.
3. Shall have an operating temperature range from -40°F (-40°C) to 130°F (54°C), 10% - 90% RH (non-condensing).
4. Shall have either a field installed BACnet® plug-in communication card which includes an EIA-485 protocol communication port, or a field installed LonWorks™ plug-in communications card.

5. The BACnet® plug in communication card shall include built-in protocol for BACNET (MS/TP and PTP modes)
6. The LonWorks™ plug in communication card shall include the Echelon processor required for all Lon applications.
7. Shall allow access of up to 62 network variables (SNVT). Shall be compatible with all open controllers
8. Baud rate Controller shall be selectable through the EIA-485 protocol communication port.
9. Shall have an LED display independently showing the status of serial communication, running, errors, power, all digital outputs, and all analog inputs.
10. Shall accept the following inputs: space temperature, setpoint adjustment, outdoor air temperature, indoor air quality, outdoor air enthalpy, compressor lock-out, fire shutdown, enthalpy switch, and fan status/filter status/ humidity/ remote occupancy.
11. Shall provide the following outputs: economizer, fan, cooling stage 1, cooling stage 2, heat stage 1, heat stage 2, exhaust.
12. Software upgrades will be accomplished by either local or remote download. No software upgrades through chip replacements are allowed.
13. Shall be natively equipped with Modbus

### **23 09 33 Electric and Electronic Control System for HVAC**

#### 23 09 33.00.A. General:

1. Shall be complete with self-contained low-voltage control circuit protected by a fuse on the 24-V transformer side (090-150 units have a resettable circuit breaker).
2. Shall utilize color-coded wiring.
3. The heat exchanger shall be controlled by the Core Command microprocessor. See heat exchanger section of this specification.
4. Unit shall include a minimum of one 8-pin screw terminal connection board for connection of control wiring.
5. Unit control board shall be provided with 7 segment readout via LCD display for status and diagnostics.

#### 23 09 33.00.A. Safeties:

1. Compressor over-temperature, over current.
2. Standard Low-pressure switch.
  - a. Units shall have low pressure, loss of charge automatic reset device that will shut off compressor when tripped.
  - b. Low pressure control:
    - Provides active protection in both heating and cooling modes at all outdoor ambient temperatures. The low pressure control is an automatic reset type and opens at approximately 15 psig and closes at approximately 40 psig. Operation is slightly different between cooling and heating modes.
3. Standard High-pressure switch.
  - a. Unit shall be equipped with high pressure switch device that will shut off compressor when tripped.
  - b. High Pressure control:
    - The high pressure control is an automatic reset type and opens at approximately 610 psig and closes at approximately 420 psig. The compressor and fan motor will stop when the high pressure control opens and will start again if the high side pressure drops to approximately 420 psig where the automatic reset high pressure control resets. If the high pressure control opens 3 times within a particular call for heating or cooling operation, the defrost control will lock out compressor and outdoor fan operation.
4. Automatic reset, motor thermal overload protector.
5. Heating section shall be provided with the following minimum protections:
  - a. High-temperature limit switches.
  - b. Induced draft motor pressure switch.
  - c. Flame rollout switch.
  - d. Flame proving controls.

### **23 09 93 Sequence of Operations for HVAC Controls**

#### **23 09 93.00 INSERT SEQUENCE OF OPERATION**

### **23 40 13 Panel Air Filters**

#### 23 41 13.00.A. Standard filter section shall

1. Shall consist of factory-installed, low velocity, throwaway 2-in. thick fiberglass filters of commercially available sizes.
2. Unit shall use only one filter size. Multiple sizes are not acceptable.
3. Filter face velocity shall not exceed 365 fpm at nominal airflows.
4. Filters shall be accessible through an access panel with “no-tool” removal as described in the unit cabinet section of the specification (23 81 19.13.H).



## **23 81 19 Self-Contained Air Conditioners**

### **23 81 19.13 Small Capacity Self-Contained Air Conditioners**

#### **23 81 19.13.A. General**

1. Outdoor, rooftop mounted, electrically controlled, heating and cooling unit utilizing a(n) hermetic scroll compressor(s) for cooling duty and gas combustion for heating duty.
2. Factory assembled, single-piece heating and cooling rooftop unit. Contained within the unit enclosure shall be all factory wiring, piping, controls, and special features required prior to field start-up.
3. Unit shall use environmentally safe, R410A refrigerant.
4. Unit shall be installed in accordance with the manufacturer's instructions.
5. Unit must be selected and installed in compliance with local, state, and federal codes.
6. Model and serial data shall be reprinted inside the control box.

#### **23 81 19.13.B. Quality Assurance**

1. Unit meets ASHRAE 90.1-2019 minimum efficiency requirements.
2. Unit shall be rated in accordance with AHRI Standards 340/360.
3. Unit shall be designed to conform to ASHRAE 15.
4. Unit shall be UL-tested and certified in accordance with ANSI Z21.47 Standards and UL-listed and certified under Canadian standards as a total package for safety requirements.
5. Insulation and adhesive shall meet NFPA 90A requirements for flame spread and smoke generation.
6. Unit casing shall be capable of withstanding 1000-hour salt spray exposure per ASTM B117 (scribed specimen).
7. Unit shall be designed in accordance with ISO 9001:2015, and shall be manufactured in a facility registered by ISO 9001:2015.
8. Roof curb shall be designed to conform to NRCA Standards.
9. Unit shall be subjected to a completely automated run test on the assembly line. The data for each unit will be stored at the factory, and must be available upon request.
10. Unit shall be designed in accordance with UL Standard 1995, Fifth Ed. including tested to withstand rain.
11. Unit shall be constructed to prevent intrusion of snow and tested to prevent snow intrusion into the control box up to 40 mph.
12. Five (5) years warranty for 3 phase, commercial applications compressor
13. Ten (10) years warranty for 3 phase, commercial applications aluminized heat exchanger
14. Twenty (20) years for 3 phase, commercial applications stainless steel heat exchanger
15. One (1) year warranty for 3 phase, commercial application parts

#### **23 81 19.13.C. Delivery, Storage, and Handling**

1. Unit shall be stored and handled per manufacturer's recommendations.
2. Lifted by crane requires either shipping top panel or spreader bars.
3. Unit shall only be stored or positioned in the upright position. 23 81 19.13.E.

#### **23 81 19.13.E. Project Conditions**

1. As specified in the contract.

#### **23 81 19.13.F. Operating Characteristics**

1. Unit shall be capable of starting and running at 115°F (46°C) ambient outdoor temperature, meeting maximum load criteria of AHRI Standard 360 at ± 10% voltage.
2. Compressor with standard controls shall be capable of operation down to 50°F (10°C), ambient outdoor temperatures. Low ambient accessory kit is necessary if mechanically cooling at ambient temperatures to 0°F (-17.7°C).
3. Unit shall discharge supply air vertically or horizontally as shown on contract drawings.
4. Unit shall be factory configured for vertical supply & return configurations.
5. Unit shall be field convertible from vertical to horizontal configuration.
6. Unit shall be capable of mixed operation: vertical supply with horizontal return or horizontal supply with vertical return.

#### **23 81 19.13.G. Electrical Requirements**

1. Main power supply voltage, phase, and frequency must match those required by the manufacturer.

23 81 19.13.H. Unit Cabinet

1. Unit cabinet shall be constructed of galvanized steel.
2. Unit cabinet exterior paint shall be pre-painted steel.
3. The sheet-metal cabinet shall be constructed of 18-gauge material for structural components with an underlying coat of G90.
4. Evaporator fan compartment interior cabinet insulation shall conform to AHRI Standards 360 minimum exterior sweat criteria. Interior surfaces shall be insulated with a minimum 1/2-in. thick, 1.6 lb density, flexible fiberglass insulation, foil faced on the air side. Aluminum foil-faced fiberglass insulation shall be used in the gas heat compartment.
5. Shall utilize uniform screw sizing.
6. Base of unit shall have a location for thru-the-base gas and electrical connections standard.
7. Base Rail
  - a. Unit shall have base rails on a minimum of 4 sides.
  - b. Holes shall be provided in the base rails for rigging shackles to facilitate maneuvering and overhead rigging.
  - c. Holes shall be provided in the base rail for moving the rooftop for fork truck.
  - d. Base rail shall be a minimum of 14 gauge thickness.
8. Condensate pan and connections:
  - a. Shall be a sloped condensate drain pan made of a non-corrosive material and be removable for cleaning.
  - b. Shall comply with ASHRAE Standard 62.
  - c. Shall use a 3/4" NPT drain connection, possible either through the bottom or side of the drain pan. Connection shall be made per manufacturer's recommendations.
  - d. Shall be able to slide out completely.
  - e. Shall be separate from the coil.
9. Standard factory installed condensate overflow sensor
10. Top panel:
  - a. Shall be a single piece top panel over indoor section.
11. Gas Connections:
  - a. All gas piping connecting to unit gas valve shall enter the unit cabinet at a single location on side of unit (horizontal plane).
  - b. Thru-the-base capability
    - i. Standard unit shall have a thru-the-base gas-line location using a continuous raised, flange around opening in the basepan.
    - ii. No basepan penetration, other than those authorized by the manufacturer, is permitted.
12. Electrical Connections
  - a. All unit power wiring shall enter unit cabinet a single, factory-prepared, continuous raised flange opening in the basepan.
  - b. Thru-the-base capability
    - i. Standard unit shall have a thru-the-base electrical location(s) using a raised, continuous raised flange opening in the basepan.
    - ii. No basepan penetration, other than those authorized by the manufacturer, is permitted.
13. Component access panels (standard)
  - a. Cabinet panels shall be easily opened for servicing.
  - b. Panels covering filters shall have hinges with 1/4 turn fasteners.

23 81 19.13.I. Gas Heat

1. General
  - a. Shall have standard two stage gas heat
  - b. Heat exchanger shall be an induced draft design. Positive pressure heat exchanger designs shall not be allowed.
  - c. Shall incorporate a direct-spark ignition system and redundant main gas valve.
  - d. Heat exchanger design shall allow combustion process condensate to gravity drain; maintenance to drain the gas heat exchanger shall not be required.
  - e. Gas supply pressure at the inlet to the rooftop unit gas valve must match that required by the manufacturer.
2. The heat exchanger shall be controlled by the Core Command microcompressor.
  - a. The Core Command board shall notify users of fault using two 7 segment displays.

3. Standard Heat Exchanger construction
  - a. Heat exchanger shall be of the tubular-section type constructed of a minimum of 20-gauge steel coated with a nominal 1.2 mil. aluminum-silicone alloy for corrosion resistance.
  - b. Burners shall be of the in-shot type constructed of aluminum-coated steel
  - c. Burners shall incorporate orifice for rated heat output up to 2,000 ft. (610m) elevation with a gas heating valve of 1050. Alternate orifices may be required depending on local gas heating valves and elevations.
  - d. Each heat exchanger tube shall contain tubulators for increased heating effectiveness.
4. Optional Stainless Steel Heat Exchanger construction
  - a. Use energy saving, direct-spark ignition system.
  - b. Use a redundant main gas valve.
  - c. Burners shall be of the in-shot type constructed of aluminum-coated steel.
  - d. All gas piping shall enter the unit cabinet at a single location on side of unit (horizontal plane).
  - e. The optional stainless steel heat exchanger shall be of the tubular-section type, constructed of a minimum of 20-gauge type 409 stainless steel.
  - f. Type 409 stainless steel shall be used in heat exchanger tubes.
  - g. Complete stainless steel heat exchanger allows for greater application flexibility.
5. Induced draft combustion motor and blower
  - a. Shall be a direct-drive, single inlet, forward-curved centrifugal type.
  - b. Shall be made from steel with a corrosion-resistant finish.
  - c. Shall be permanently lubricated sealed bearings.
  - d. Shall have inherent thermal overload protection.
  - e. Shall have an automatic reset feature.

23 81 19.13.J. Coils

1. Standard Aluminum/MicroChannel Coils:
  - a. Standard evaporator and condenser coils shall be aluminum.
  - b. Evaporator and condenser coils shall be leak tested to 150 psig, pressure tested to 400 psig, and qualified to UL 1995 burst test at 2,200 psi.

23 81 19.13.K. Refrigerant Components

1. Refrigerant circuit shall include the following control, safety, and maintenance features:
  - a. TXV metering system shall prevent mal-distribution of two-phase refrigerant.
  - b. Refrigerant filter drier.
  - c. Service gauge connections on suction and discharge lines.
  - d. External pressure gauge ports access shall be located in front exterior of cabinet.
  - e. External gauge ports shall be lockable.
2. Compressors
  - a. Unit shall use one fully hermetic, 2-stage scroll compressor for each independent refrigeration circuit.
  - b. Compressor motors shall be cooled by refrigerant gas passing through motor windings.
  - c. Compressors shall be internally protected from high discharge temperature conditions.
  - d. Compressors shall be protected from an over-temperature and over-amperage conditions by an internal, motor overload device.
  - e. Compressor shall be factory mounted on rubber grommets.
  - f. Compressor motors shall have internal line break thermal and current overload protection.
  - g. Crankcase heaters shall not be required for normal operating range.
  - h. Compressor shall have molded electrical plug.

23 81 19.13.L. Filter Section

1. Filters access is specified in the unit cabinet section of this specification.
2. Filters shall be held in place by filter tray, facilitating easy removal and installation.
3. Shall consist of factory-installed, low velocity, throw-away 2-in. thick fiberglass filters.
4. Filter face velocity shall not exceed 320 fpm at nominal airflows.
5. Filters shall be standard, commercially available sizes.
6. Only one size filter per unit is allowed.

23 81 19.13.M. Evaporator Fan and Motor

1. Evaporator fan motor:
  - a. Shall have permanently lubricated bearings
  - b. Shall have inherent automatic-reset thermal overload protection.
  - c. Shall have a maximum continuous bhp rating for continuous duty operation; no safety factors above that rating shall be required.
2. Belt-driven Evaporator Fan:
  - a. Belt drive shall include an adjustable-pitch motor pulley.
  - b. Shall use sealed, permanently lubricated ball-bearing type.
  - c. Blower fan shall be double-inlet type with forward-curved blades.
  - d. Shall be constructed from steel with a corrosion resistant finish and dynamically balanced.
3. Blower Assembly
  - a. Entire assembly shall be able to slide out completely.
  - b. Shall be able to slide-out without the removal of the roof and condenser fan motors.

23 81 19.13.N. Condenser Fans and Motors

1. Condenser fan motors:
  - a. Shall be a totally enclosed motor.
  - b. Shall use permanently lubricated bearings.
  - c. Shall have inherent thermal overload protection with an automatic reset feature.
  - d. Shall use a shaft-down design. Shaft-up designs including those with "rain-slinger devices" shall not be allowed.
2. Condenser Fans shall:
  - a. Shall be a direct-driven propeller type fan
  - b. Shall have aluminum blades riveted to corrosion-resistant steel spiders and shall be dynamically balanced.

23 81 19.13.O. Special Features

1. Integrated Economizers:
  - a. Integrated, gear-driven parallel modulating blade design type capable of simultaneous economizer and compressor operation.
  - b. Independent modules for vertical or horizontal return configurations shall be available. Vertical return modules shall be available as a factory installed option.
  - c. Damper blades shall be galvanized steel with metal gears. Plastic or composite blades on intake or return shall not be acceptable.
  - d. Shall include all hardware and controls to provide free cooling with outdoor air when temperature and/or humidity are below setpoints.
  - e. Shall be equipped with gear driven dampers for both the outdoor ventilation air and the return air for positive air stream control.
  - f. Shall be equipped with low-leakage dampers, not to exceed 2% leakage at 1 in. wg pressure differential.
  - g. Shall be capable of introducing up to 100% outdoor air.
  - h. Shall be equipped with a barometric relief damper capable of relieving up to 35% return air, depending on the airflow.
  - i. Shall be designed to close damper(s) during loss-of-power situations with spring return built into motor.
  - j. Enthalpy sensor shall be provided as standard. Outdoor air sensor set point shall be adjustable and shall range from 40 to 100°F / 4 to 38°C. Additional sensor options shall be available as accessories.
  - k. The economizer controller shall also provide control of an accessory power exhaust unit function. Factory set at 70%, with a range of 0% to 100%.
  - l. The economizer shall maintain minimum airflow into the building during occupied period and provide design ventilation rate for full occupancy. A remote potentiometer may be used to override the damper set point.
  - m. Dampers shall be completely closed when the unit is in the unoccupied mode.
  - n. Economizer controller shall accept a 2-10Vdc CO2 sensor input for IAQ/DCV control. In this mode, dampers shall modulate the outdoor-air damper to provide ventilation based on the sensor input.
  - o. Actuator shall be direct coupled to economizer gear. No linkage arms or control rods shall be acceptable.
  - p. Economizer controller shall provide indications when in free cooling mode, in the DCV mode, or the exhaust fan contact is closed.
  - q. Economizer wire harness will have provision for smoke detector available in supply and return options.
  - r. Shall provide fault detection and diagnostics (FDD) system in accordance with local code. Faults shall be communicated out on an alarm signal.

2. Manual damper
  - a. Manual damper package shall consist of damper, air inlet screen, and rain hood which can be preset to admit up to 50% outdoor air for year-round ventilation.
3. Liquid Propane (LP) Conversion Kit (sold separately)
  - a. Kit shall contain all the necessary hardware and instructions to convert a standard natural gas unit for use with liquefied propane, up to 2000 ft (610m) elevation.
4. Condenser Coil Hail Guard Assembly
  - a. Shall protect against damage from hail.
  - b. Shall be louvered style.
5. Unit-Mounted, Non-Fused Disconnect Switch:
  - a. Switch shall be factory or field installed.
  - b. Switch shall be internally mounted with external access.
  - c. National Electric Code (NEC) and UL approved non-fused switch shall provide unit power shutoff.
  - d. Shall be accessible from outside the unit.
  - e. Shall provide local shutdown and lockout capability.
6. Convenience Outlet:
  - a. Non-Powered convenience outlet.
  - b. Outlet shall be powered from a separate 115-120v power source.
  - c. A transformer shall not be included.
  - d. Outlet shall be field-installed and internally mounted with easily accessible 115-v female receptacle.
  - e. Outlet shall include 15 amp GFI receptacle with independent fuse protection.
  - f. Outlet shall be accessible from outside the unit.
7. Flue Hood:
  - a. Flue discharge deflector shall direct unit exhaust vertically instead of horizontally.
8. Propeller Power Exhaust:
  - a. Power exhaust shall be used in conjunction with an integrated economizer.
  - b. Independent modules for vertical or horizontal return configurations shall be available.
  - c. Horizontal power exhaust is shall be mounted in return ductwork.
  - d. Power exhaust shall be controlled by economizer controller operation. Exhaust fans shall be energized when dampers open past the 0-100% adjustable setpoint on the economizer control.
  - e. Capable of adjustable but constant volume.
9. Dehumidification
  - a. Shall utilize a dual-phase hot gas reheat control sequence.
  - b. Shall be installed with a thermostat or space temperature sensor and an indoor relative humidity sensor, which shall connect to the Rooftop Unit Controller (RTU-C).
  - c. Shall provide neutral air to the occupied space.
  - d. Shall have two modes: Cooling and Dehumidification.
  - e. In cooling mode, the vapor refrigerant shall remove the heat to the outdoor coil, where heat is released outdoor. This allows the refrigerant to condense and become a subcooled liquid and the process shall repeat itself.
  - f. In dehumidification mode, the refrigerant shall absorb heat via the indoor coil from the cooling area. The heat shall be carried via a parallel path to then release heat back into the cooling area allowing for the dehumidification.
  - g. Modulate reheat coil refrigerant temperature via outdoor fan motor controller to achieve neutral air.
  - h. Variable Frequency Drive shall allow the unit to operate with two stages of heat.
10. Roof Curbs (Vertical):
  - a. Formed galvanized steel with wood nailer strip and shall be capable of supporting entire unit weight.
  - b. Permits installation and securing of ductwork to curb prior to mounting unit on the curb.
11. Return Air Enthalpy Sensor:
  - a. The return air enthalpy sensor shall be used in conjunction with an outdoor air enthalpy sensor to provide differential enthalpy control.

12. Indoor Air Quality (CO<sub>2</sub>) Sensor:
    - a. Shall be able to provide demand ventilation indoor air quality (IAQ) control.
    - b. The IAQ sensor shall be available in duct mount, wall mount, or wall mount with LED display. The set point shall have adjustment capability.
  13. Smoke detectors:
    - a. Shall be a Four-Wire Controller and Detector.
    - b. Shall be environmental compensated with differential sensing for reliable, stable, and drift-free sensitivity.
    - c. Shall use magnet-activated test/reset sensor switches.
    - d. Shall have tool-less connection terminal access.
    - e. Shall have a recessed momentary switch for testing and resetting the detector.
    - f. Controller shall include:
      - One set of normally open alarm initiation contacts for connection to an initiating device circuit on a fire alarm control panel
      - Two Form-C auxiliary alarm relays for interface with rooftop unit or other equipment
      - One Form-C supervision (trouble) relay to control the operation of the Trouble LED on a remote test/reset station
      - Capable of direct connection to two individual detector modules.
      - Can be wired to up to 14 other duct smoke detectors for multiple fan shutdown applications.
  14. Barometric relief
    - a. Shall include damper, seals, hard-ware, and hoods to relieve excess building pressure.
    - b. Damper shall gravity-close upon shutdown.
  15. Time Guard
    - a. Shall prevent compressor short cycling by providing a 5-minute delay ( $\pm 2$  minutes) before restarting a compressor after shutdown for any reason.
    - b. One device shall be required per compressor.
  16. Standard Factory installed Overflow Switch
    - a. Switch shall monitor the condensate level in drain pan and stops compression operation when overflow conditions occur.
  17. Access Panels
    - a. Hinges with 1/4 turn fasteners shall be permanently attached.
    - b. Hinges shall be powder coated and made from stainless steel.
- 26 29 23.12.P. Adjustable Frequency Drive
1. Unit shall be supplied with an electronic variable frequency drive for the supply air fan.
  2. Drive shall be factory installed in an enclosed cabinet.
  3. Drive shall meet UL Standard 95-5V.
  4. The completed unit assembly shall be UL listed.
  5. Drives are to be accessible through a tooled access hinged door assembly.
  6. The unit manufacturer shall install all power and control wiring.
  7. The supply air fan drive output shall be controlled by the factory installed main unit control system and drive status and operating speed shall be monitored and displayed at the main unit control panel.
  8. Drive shall be programmed and factory run tested in the unit.

**BEFORE PURCHASING THIS APPLIANCE, READ IMPORTANT ENERGY COST AND EFFICIENCY INFORMATION AVAILABLE FROM YOUR RETAILER.**

**GENERAL TERMS OF LIMITED WARRANTY\***

Friedrich® will furnish a replacement for any part of this product which fails in normal use and service within the applicable periods stated, in accordance with the terms of the limited warranty.

**\*For complete details of the Limited and Conditional Warranties, including applicable terms and conditions, contact your local contractor or the Manufacturer for a copy of the product warranty certificate.**

<b>Compressor</b>	
3 Phase, Commercial Applications .....	Five (5) Years
<b>Parts</b>	
3 Phase, Commercial Applications .....	One (1) Year







**FRIEDRICH**

1 8 8 3

**Before proceeding with installation, refer to installation instructions packaged with each model, as well as complying with all Federal, State, Provincial, and Local codes, regulations, and practices.**

© 2023 Rheem Manufacturing Company. Friedrich trademarks owned by Rheem Manufacturing Company.

*In keeping with its policy of continuous progress and product improvement, Friedrich reserves the right to make changes without notice.*

Friedrich • 5600 Old Greenwood Road  
Fort Smith, Arkansas 72908 • [www.friedrich.com](http://www.friedrich.com)

Friedrich • 125 Edgeware Road, Unit 1  
Brampton, Ontario • L6Y 0P5