



FRIEDRICH

1 8 8 3

**Friedrich® Commercial *F-Series*
Packaged Air Conditioner**



RLNL-H Series

With ClearControl™

Nominal Sizes 15-25 Tons [52.8-87.9 kW]

ASHRAE 90.1-2019 Compliant



TABLE OF CONTENTS

Unit Features & Benefits	3-7
Model Number Identification	8
Options.....	9
Selection Procedure.....	10
General Data	
RLNL-H Series.....	11-16
Gross Systems Performance Data	
RLNL-H Series.....	17-19
Indoor Airflow Performance	
RLNL-H Series.....	20-29
Electrical Data	
RLNL-H Series.....	30-32
Electric Heater Kits	33-34
Dimensional Data	35-38
Accessories	39-53
Mechanical Specifications	54-59
Limited Warranty	60



RLNL-H STANDARD FEATURES INCLUDE:

- R-410A HFC refrigerant.
- Complete factory charged, wired and run tested.
- Scroll compressors with internal line break overload and high-pressure protection.
- Dual stage compressor on all models.
- Convertible airflow – vertical downflow or horizontal sideflow.
- TXV refrigerant metering system on each circuit.
- High Pressure and Low Pressure/Loss of charge protection standard on all models.
- Solid Core liquid line filter drier on each circuit.
- Single slab, single pass designed evaporator and condenser coils facilitate easy cleaning for maintaining high efficiencies.
- Cooling operation up to 125 degree F ambient.
- Foil faced insulation encapsulated throughout entire unit minimizes airborne fibers from the air stream.
- Hinged major access door with heavy-duty gasketing, 1/4 turn latches and door retainers.
- Slide Out Indoor fan assembly for added service convenience.
- Base pan with drawn supply and return opening for superior water management.
- Forkable base rails for easy handling and lifting.
- Single point electrical connections.
- Internally sloped slide out condensate pan conforms to ASHRAE 62 standards.
- High performance belt drive motor with variable pitch pulleys and quick adjust belt system.
- Permanently lubricated evaporator, condenser and gas heat inducer motors.
- Condenser motors are internally protected, totally enclosed with shaft down design.
- 2 inch filter standard with slide out design.
- 24 volt control system with resettable circuit breakers.
- Colored and labeled wiring.
- Copper tube/Aluminum Fin coils. (Exception: C241 has microchannel condenser coils)
- Supplemental electric heat provides 100% efficient heating.
- Factory Installed ClearControl™ (DDC) and sensors which can connect to LonWorks™ or BACnet® BAS systems for remote monitoring and control.
- Variable Frequency Drive (VFD) meet ASHRAE 90.1-2010 and California Title 24.
- MERV 8 & MERV 13 filters are available as an accessory.
- Standard Modbus interface.

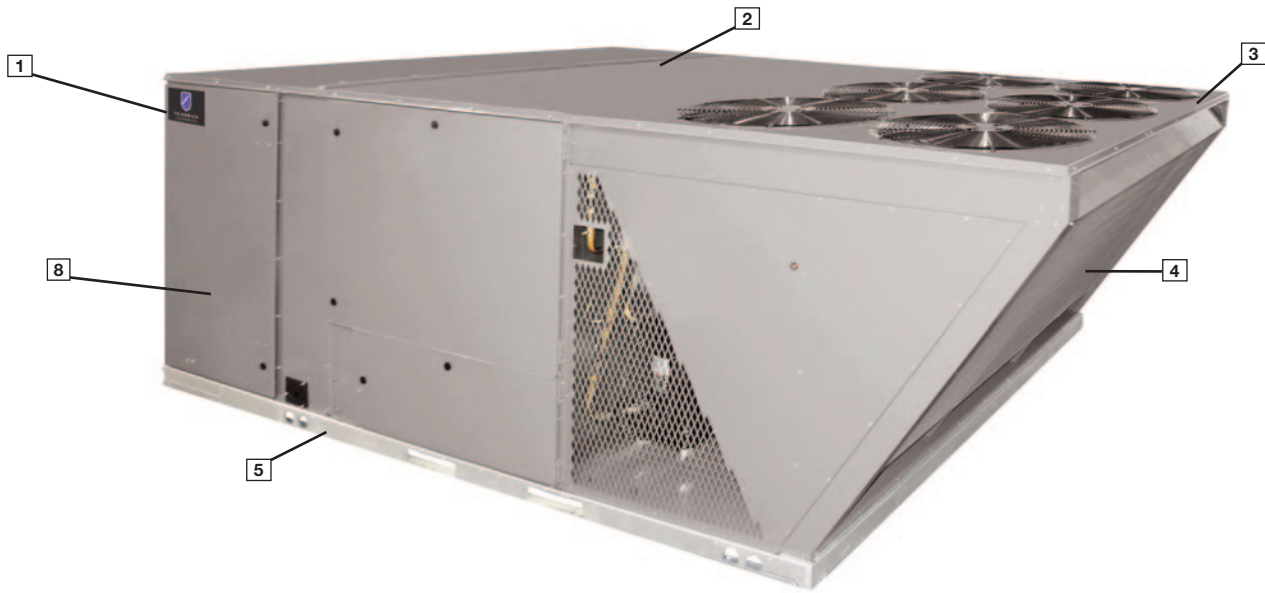

Friedrich® Packaged equipment is designed from the ground up with the latest features and benefits required to compete in today's market. The clean design stands alone in the industry and is a testament to the quality, reliability, ease of installation and serviceability that goes into each unit. Outwardly, the large Friedrich label (1) identifies the brand to the customer. The sheet-metal cabinet (2) uses nothing less than 20-gauge material for structural components with an underlying coat of G90. To ensure the leak-proof integrity of these units, the design utilizes a top with a 1/8" drip lip (3), gasket-protected panels and screws. (4) The outdoor coil is slanted to protect from hail. Every Friedrich packaged unit uses the toughest finish in the industry, using electro deposition baked-on enamel tested to withstand a rigorous 1000-hour salt spray test, per ASTM B117.

Anything built to last must start with the right foundation. In this case, the foundation is 14-gauge, commercial-grade, full-perimeter base rails (5), which integrate fork slots and rigging holes to save set-up time on the job site. The base pan is stamped, which forms a 1-1/8" flange around the supply and return cover and has eliminated the worry of water entering the conditioned space (6). The drainpan (7) is made of plastic that resists the growth of harmful bacteria and is sloped for the latest IAQ benefits. Furthermore, the drain pan slides out for easy cleaning. The insulation has been placed on the underside of the basepan, removing areas that would allow for potential moisture accumulation, which can facilitate growth of harmful bacteria. All insulation is secured with both adhesive and mechanical fasteners, and all edges are hidden.

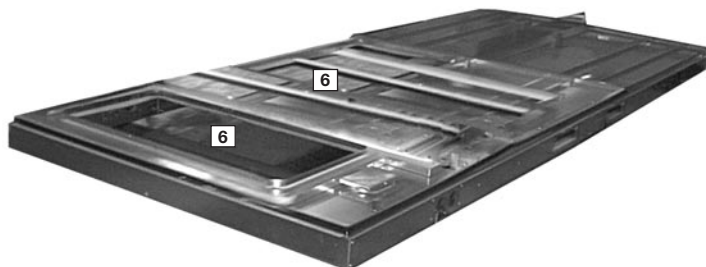

During development, each unit was tested to U.L. 1995, AHRI 340-360 and other Friedrich-required reliability tests. Friedrich adheres to stringent ISO 9001:2015 quality procedures, and each unit bears the U.L. and AHRI certification labels located on the unit nameplate (8). Contractors can rest assured that when a Friedrich packaged unit arrives at the job, it is ready to go with a factory charge and quality checks.

Access to all major compartments is from the front of the unit, including the filter and electrical compartment, blower compartment, heating section, and outdoor section. Each panel is permanently embossed with the compartment name (control/filter access, blower access and furnace access).

Electrical and filter compartment access is through a large, hinged-access panel with 1/4 turn latches. On the outside of the panel is the unit nameplate, which contains the model and serial number, electrical data and other important unit information.

The unit charging chart is located on the inside of the electrical and filter compartment door. Electrical wiring diagrams are found on the control box cover, which allows contractors to move them to more readable locations. To the right of the control box the model and serial number can be found. Having this information on the inside will assure model identification for the life of the product. The production line quality test assurance label is also placed in this location (9). The two-inch throwaway filters (10) are easily removed on a tracked system for easy replacement.

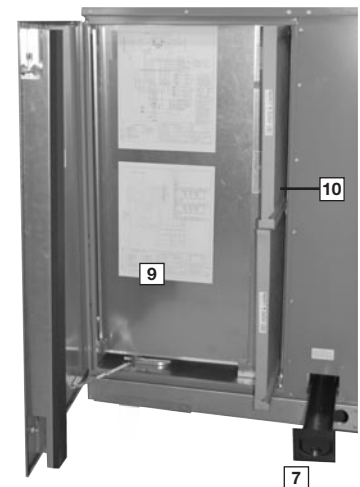

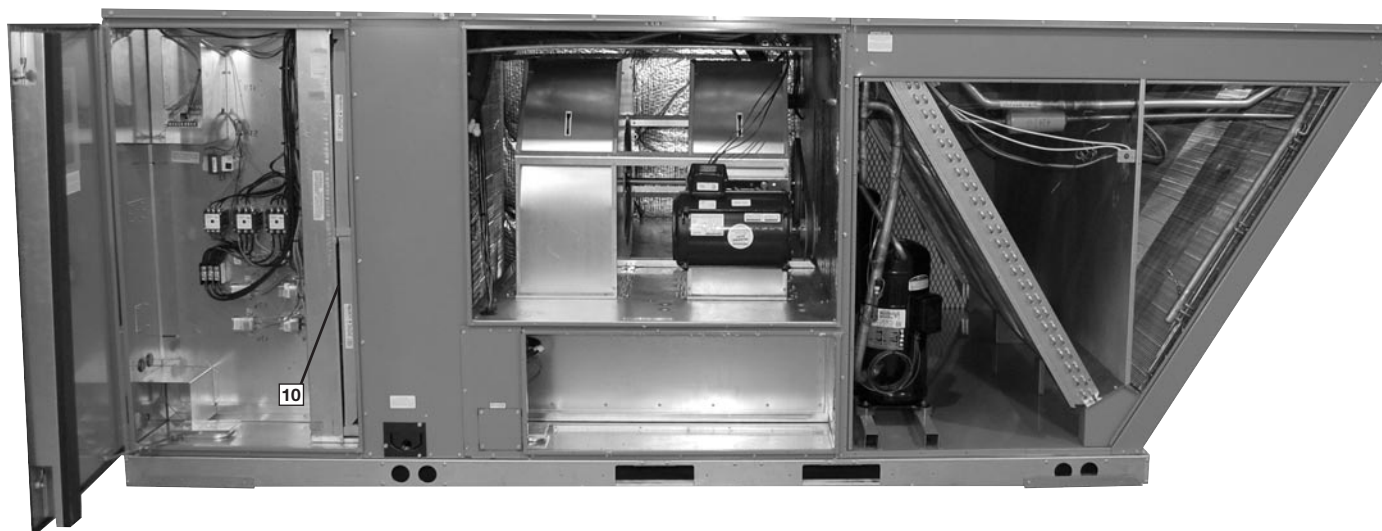

Inside the control box (10), each electrical component is clearly identified with a label that matches the component to the wire diagram for ease of trouble shooting. All wiring is numbered on each end of the termination and color-coded to match the wiring diagram. The control transformer has a low voltage circuit breaker that trips if a low voltage electrical short occurs. There is a blower contactor and contactor for each compressor.

As part of the ClearControl™ system which allows real time monitoring and communication between rooftop units, the RLNL-H Packaged Air Conditioner has a Rooftop Unit Controller (RTU-C) factory mounted and wired in the control panel. The RTU-C is a solid-state microprocessor-based control board that provides flexible control and extensive diagnostics for all unit functions. The RTU-C through proportional/integral control algorithms perform specific unit functions that govern unit operation in response to: zone conditions, system temperatures, system pressures, ambient conditions and electrical inputs. The RTU-C features a 16 x 2 character LCD display and a five-button keypad for local configuration and direct diagnosis of the system (12). New features include a clogged filter switch (CFS), fan proving switch (FPS), return air temperature sensor (RAT), discharge air temperature sensor (DAT) and outdoor air temperature sensor (OAT). Freeze sensors (FS) are used in place of freezestats to allow measurement of refrigerant suction line temperatures. The RLNL-H Packaged Air Conditioner with the ClearControl™ is specifically designed to be applied in four distinct applications:



The RLNL-H is compatible with a third party building management system that supports the BACnet Application Specific Controller device profile, with the use of a field installed BACnet Communication Module. The BACnet Communication Module plugs into the unit RTU-C controller and allows communication between ClearControl™ and the BACnet MSTP or IP network. A zone sensor, a BACnet network zone sensor, a BACnet thermostat or DDC controller may be used to send the zone temperature or thermostat demands to the RTU-C. The BACnet Communication Module is compatible with MSTP EIA-485 daisy chain networks communicating at 38.4 bps. It is compatible with twisted pair, shielded cables.

The RLNL-H is compatible with a third party building management system that supports the LonMark Space Comfort Controller (SCC) functional profile or LonMark Discharge Air Controller (DAC) functional profile. This is accomplished with a field installed LonMark communication module. The LonMark Communication Module plugs onto the RTU-C controller and allows communication between ClearControl™ and a LonWorks Network. A zone sensor, a LonTalk network zone sensor, or a LonTalk thermostat or DDC controller may be used to send the zone temperature or thermostat demands to the RTU-C. The LonMark Communication Module utilizes an FTT-10A free topology transceiver communicating at 78.8 kbps. It is compatible with Echelon qualified twisted pair cable, Belden 8471 or NEMA Level 4 cables. The Module can communicate up to 1640 ft. with no repeater. The LonWorks limit of 64 nodes per segment applies to this device.

The RLNL-H is compatible with a programmable 24 volt thermostat. Connections are made via conventional thermostat screw terminals. Extensive unit status and diagnostics are displayed on the LCD screen of the RTU-C.

The RLNL-H is compatible with a zone sensor and mechanical or solid state time clock connected to the RTU-C. Extensive unit status and diagnostics are displayed on the LCD screen of the ClearControl™.

A factory or field installed Comfort Alert® module is available for power phase-monitoring protection and additional compressor diagnostics. The alarms can be displayed on the ClearControl™ display, through the (BAS) network, or connected to the "L-Terminal" of a thermostat for notification.

Factory installed VFD (13) (variable frequency drive) supply fan optimizes energy usage year round by providing a lower speed for first stage cooling operation improving IEER's by up to 33% over the conventional constant fan system. Furthermore, operating in the constant fan mode at the reduced speed can use as little as 1/8th of the energy of a conventional constant fan system. Also, by operating at a lower speed on first stage cooling up to 126% more moisture is removed improving comfort during low load operation. The VFD equipped units meet California Title 24 and ASHRAE 90.1-2019 requirements for multi blower speed control. VFD also ramps up to the desired speed reducing stress on the supply fan components and reducing the noise from sudden inrush of air. Because the airflow is cut in half during first stage cooling and constant fan operation, noise is much less during these modes of operation.

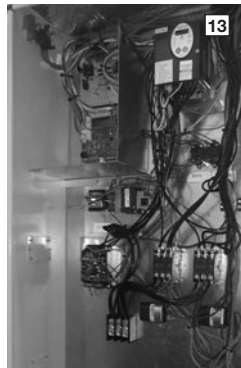

For added convenience in the field, a factory-installed convenience outlet (14) is available. Low and High voltage can enter either from the side or through the base. Low-voltage connections are made through the low-voltage terminal strip. For ease of access, the U.L.-required low voltage barrier can be temporarily removed for low-voltage termination and then reinstalled. The high-voltage connection is terminated at the high voltage terminal block. The suggested mounting for the field-installed disconnect is on the exterior side of the electrical control box.



The blower compartment is to the right of the control box and can be accessed by 1/4 turn latches. To allow easy maintenance of the blower assembly, the entire assembly easily slides out by removing four

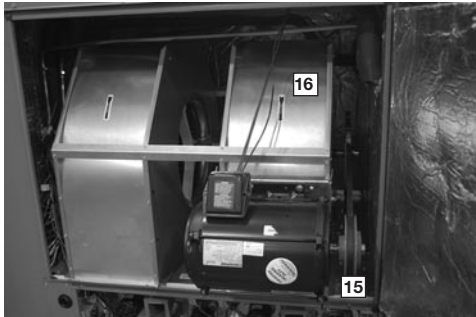

#10 screws from the blower assembly. The adjustable motor pulley (15) can easily be adjusted by loosening the bolts on either side of the motor mount. Removing the bolts allows for easy removal of the blower pulley by pushing the blower assembly up to loosen the belt. Once the pulley is removed, the motor sheave can be adjusted to the desired number of turns, ranging from 1 to 6 turns open. Where the demands for the job require high static, Friedrich® has high-static drives available that deliver nominal airflow up to 2" of static. By referring to the airflow performance tables listed in the installation instructions, proper static pressure and CFM requirements can be dialed in. The scroll housing (16) and blower scroll provide quiet and efficient airflow. The blower sheave is secured by an "H" bushing which firmly secures the pulley to the blower shaft for years of trouble-free operation. The "H" bushing allows for easy removal of the blower pulley from the shaft, as opposed to the use of a set screw, which can score the shaft, creating burrs that make blower-pulley removal difficult.

Also inside the blower compartment are the optional low-ambient controls (17). The optional low-ambient controls allow for operation of the compressors down to 0 degrees ambient temperature by cycling the outdoor fans on high pressure. The freeze sensor protects the compressor if the evaporator coil gets too cold (below freezing) due to low airflow, and allows monitoring of the suction line temperature on the controller display. The sensor clips on the suction line near the evaporator outlet.



Inside the blower compartment the interlaced evaporator can also be viewed. The evaporator uses enhanced fin technology for maximum heat transfer. The TXV metering device assures even distribution of refrigerant throughout the evaporator.

Wiring throughout the unit is neatly bundled and routed. Where wire harnesses go through the condenser bulkhead or blower deck, a molded wire harness assembly (18) provides an airtight and water-tight seal, and provides strain relief. Care is also taken to tuck raw edges of insulation behind sheet metal to improve indoor air quality.

The heating compartment contains the latest electric furnace technology on the market. The 100% efficient electric furnace can be factory-installed or easily field-installed. Built with ease-of-installation in mind, the electric furnace is completely wired up for slide-in, plug-and-play installation in the field. With choices of up to four kilowatt offerings, the contractor is assured to get the correct amount of heating output to meet the designed heating load.

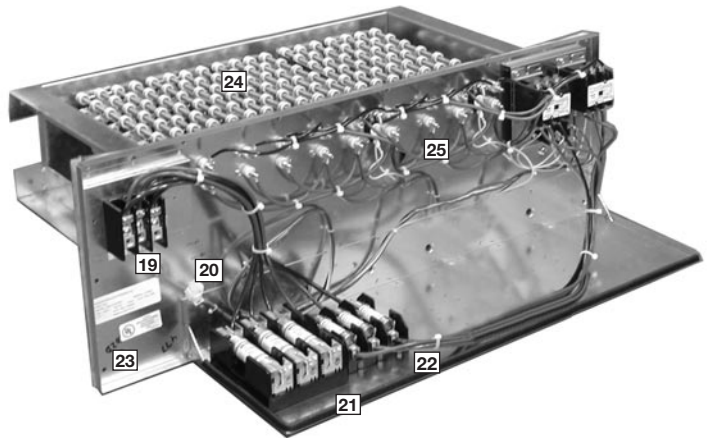
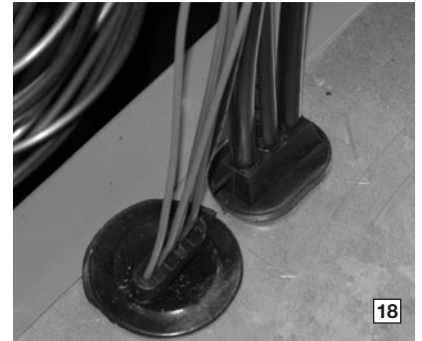

Power hook-up in the field is easy with single-point wiring to a terminal block (19) and a polarized plug for the low-voltage connection (20). The electric furnace comes with fuses for the unit (21) and for the electric furnace (22), and is UL certified (23). The electric heating elements are of a wound-wire construction (24) and isolated with ceramic bushings. The limit switch (25) protects the design from over-temperature conditions.

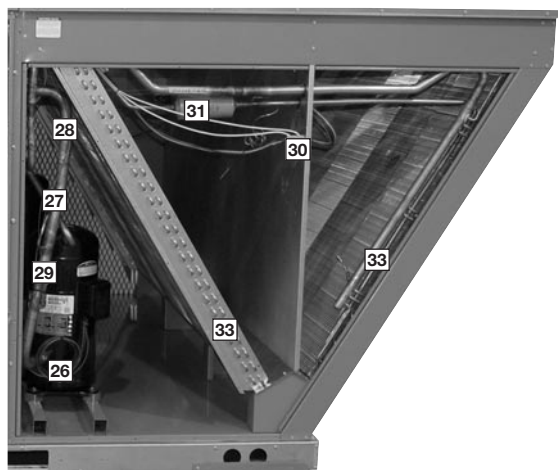

The compressor compartment houses the heartbeat of the unit. The scroll compressor (26) is known for its long life, and for reliable, quiet, and efficient operation. The suction and discharge lines are designed with shock loops (27) to absorb the strain and stress that the starting torque, steady state operation, and shut down cycle impose on the refrigerant tubing. Each compressor and circuit is independent for built-in redundancy, and each circuit is clearly marked throughout the system. Each unit has two stages of efficient cooling operation, first stage is approximately 50% of second stage.

In the outdoor section are the external gauge ports (28). With the gauge ports mounted externally, an accurate diagnosis of system operation can be performed quickly and easily. Also located in this area are the refrigerant safety devices: the low-pressure switches (29) and the high-pressure switches. (30) The high-pressure switches will shut off the compressors if pressures exceeding 610 psig are detected as may occur if the outdoor fan motor fails. The low pressure switches shut off the compressors if low pressure is detected due to loss of refrigerant charge. The factory-installed high and low pressure switches are brazed into the appropriate high or low side and wired appropriately.

Each unit comes standard with filter dryer (31). The condenser fan motor (32) can easily be accessed and maintained by removing the protective fan grille. The polarized plug connection allows the motor to be changed quickly and eliminates the need to snake wires through the unit.

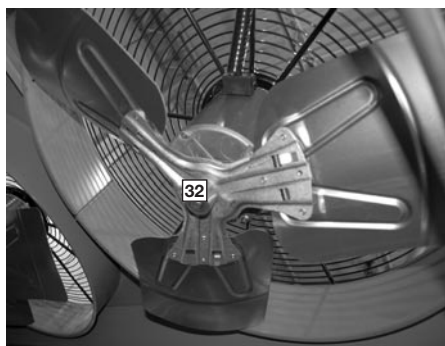

The outdoor coil uses the latest enhanced fin design (33) for the most effective method of heat transfer. The outdoor coil is slanted to protect the unit from Mother Nature.

Each unit is designed for both downflow or horizontal applications (34) for job configuration flexibility. The return air compartment

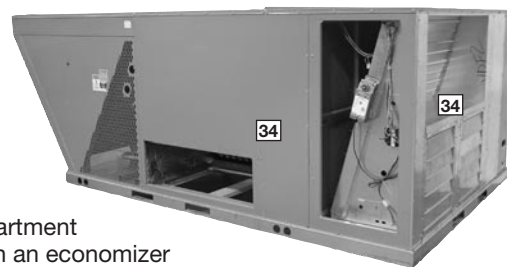

can also contain an economizer (35). Three models exist; two for downflow applications, and one for horizontal applications. (A downflow economizer with factory installed smoke detector in the return section is available). Each unit is pre-wired for the economizer to allow quick plug-in installation. The downflow economizer is also available as a factory-installed option. The economizer, which provides free cooling when outdoor conditions are suitable and also provides fresh air to meet local requirements, comes standard with single enthalpy controls. The controls can be upgraded to dual enthalpy easily in the field. The direct drive actuator combined with gear drive dampers has eliminated the need for linkage adjustment in the field. The economizer control has a minimum position setpoint, an outdoor-air setpoint, a mix-air setpoint, and a CO₂ setpoint. Barometric relief is standard on all economizers. Power Exhaust is easily field-installed. The power exhaust is housed in the barometric relief opening and is easily slipped in with a plug-in assembly. The wire harness to the economizer also has accommodations for a smoke detector.

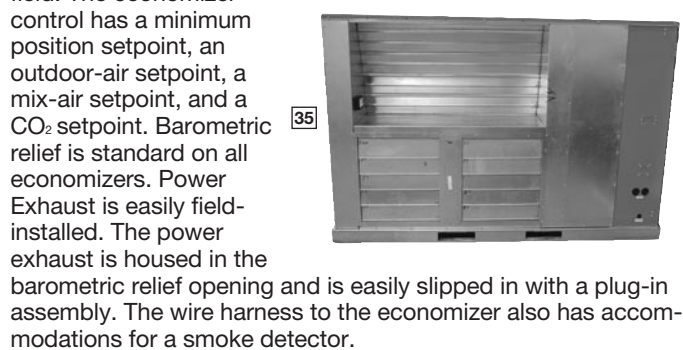

The damper minimum position, actual damper position, power exhaust on/off setpoint, mixed air temperature limit setpoint and Demand Controlled Ventilation (DCV) setpoint can be read and adjusted at the unit controller display or remotely through a network connection.

The Space CO₂ level, mixed air temperature, and Economizer Status (Free Cooling Available, Single or Dual Enthalpy) can be read at the unit controller display or remotely through a network connection. Economizer Faults will trigger a network Alarm and can be read at the unit controller display or remotely through a network connection.

The Friedrich® roofcurb (36) is made for toolless assembly at the jobsite by inserting a pin into the hinged corners (37), which makes the assembly process quick and easy.

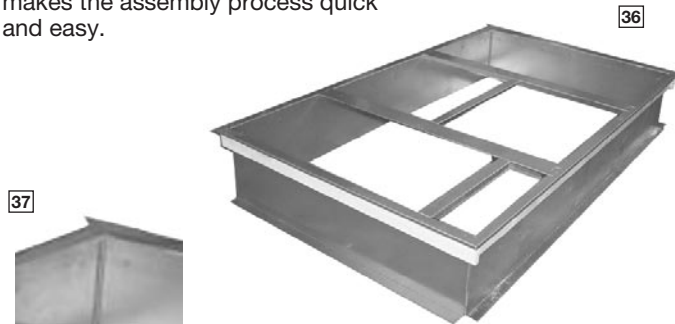

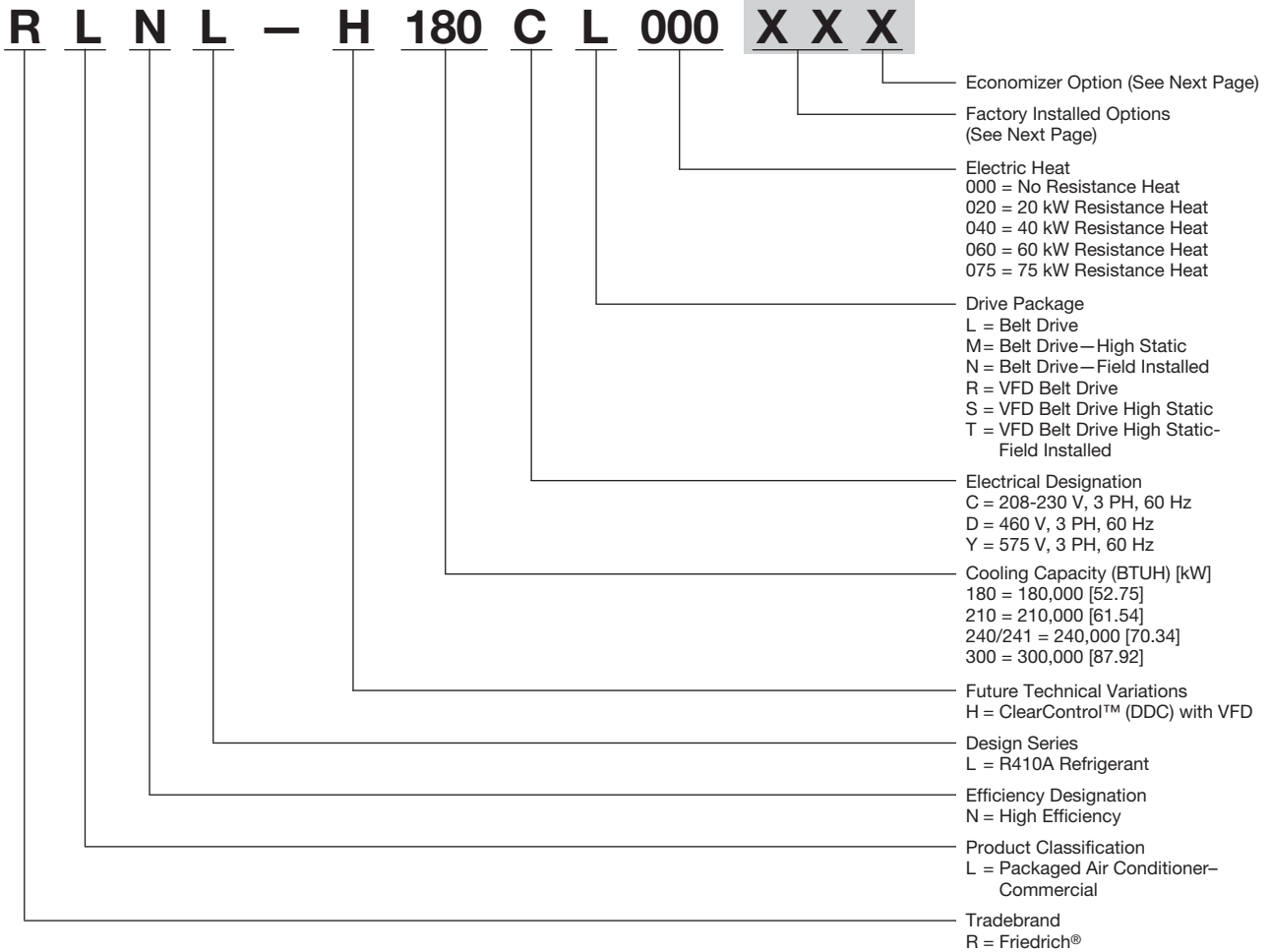

[] Designates Metric Conversions

FACTORY INSTALLED OPTION CODES FOR RLNL-H (15-25 TON) [52.8-87.9 kW]

Option Code	Hail Guard	Non-Powered Convenience Outlet	Low Ambient/ Comfort Alert
AD	X		
AG		X	
AR			X
JD	X		X
BJ	X	X	
JE		X	X
CZ	X	X	X

Example: RLNL-H180CL000XXX (where XX is factory installed option)

Example: No Options

RLNL-H180CL000

Example: No Options with factory installed economizer

RLNL-H180CL000AAH

Example: Options with low ambient/comfort alert and no factory installed economizer

RLNL-H180CL000ARA

Example: Options same as above with factory installed economizer

RLNL-H180CL000ARH

ECONOMIZER SELECTION FOR RLNL-H (15-25 TON) [52.8-87.9 kW]

Option Code	No Economizer	DDC Single Enthalpy Economizer* With Barometric Relief	DDC Single Enthalpy Economizer* With Barometric Relief and Smoke Detector
A	X		
H		X	
J			X

"x" indicates factory installed option.

*Downflow economizer only.

Instructions for Factory Installed Option(s) Selection

Note: Three characters following the model number will be utilized to designate a factory-installed option or combination of options. If no factory option(s) is required, nothing follows the model number.

Step 1. After a basic rooftop model is selected, choose a *two-character* option code from the FACTORY INSTALLED OPTION SELECTION TABLE.

Proceed to Step 2.

Step 2. The last option code character is utilized for factory-installed economizers. Choose a character from the FACTORY INSTALLED ECONOMIZER SELECTION TABLE.

[] Designates Metric Conversions

To select an RLNL-H Cooling and Heating unit to meet a job requirement, follow this procedure, with example, using data supplied in this specification sheet.

1. DETERMINE COOLING AND HEATING REQUIREMENTS AND SPECIFIC OPERATING CONDITIONS FROM PLANS AND SPECS.

Example:

Voltage—	240 V – 3 Phase – 60 Hz
Total Cooling Capacity—	205,000 BTUH [60.0 kW]
Sensible Cooling Capacity—	155,000 BTUH [45.4 kW]
Heating Capacity—	235,000 BTUH [68.8 kW]
*Condenser Entering Air—	95°F [35°C] DB
*Evaporator Mixed Air Entering—	65°F [18.3] WB; 78°F [25.6] DB
*Indoor Air Flow (vertical)—	7200 CFM [3398 L/s]
*External Static Pressure—	0.70 in. WG [.17 kPa]

2. SELECT UNIT TO MEET COOLING REQUIREMENTS.

Since total cooling is within the range of a nominal 20 ton [70.3 kW] unit, enter cooling performance table at 95°F [35.0 °C] DB condenser inlet air. Interpolate between 63°F [17.2 °C] WB and 67°F [19.4 °C] WB to determine total and sensible capacity and power input for 65°F [18.3 °C] WB evaporator inlet air at 7725 CFM [3645 L/s] indoor air flow (table basis):

Total Cooling Capacity = 238,300 BTUH [69.76 kW]
 Sensible Cooling Capacity = 192,500 BTUH [56.38 kW]
 Power Input (Compressor and Cond. Fans) = 18,200 watts

Use formula in note ① to determine sensible capacity at 78°F [25.6] DB evaporator entering air:

$$192,550 + (1.10 \times 7,200 \times (1 - 0.11) \times (78 - 80))$$

$$\text{Sensible Cooling Capacity} = 178,452 \text{ BTUH [52.25 kW]}$$

3. CORRECT CAPACITIES OF STEP 2 FOR ACTUAL AIR FLOW.

Select factors from airflow correction table at 7200 CFM [3398 L/s] and apply to data obtained in step 2 to obtain gross capacity:

Total Capacity = 238,300 x .99 = 235,868 BTUH [69.06 kW]
 Sensible Capacity = 178,452 x 0.96 = 171,314 BTUH [50.16 kW]
 Power Input = 18,200 x 0.99 = 18,018 Watts

These are Gross Capacities, not corrected for blower motor heat or power.

4. DETERMINE BLOWER SPEED AND WATTS TO MEET SYSTEM DESIGN.

Enter Indoor Blower performance table at 7200 CFM [3398 L/s]. Total ESP (external static pressure) per the spec of 0.70 in. WG [.17 kPa] includes the system duct and grilles. Add from the table 'Component Air Resistance', 0.01 in. WG [.00 kPa] for wet coil, 0.08 in. WG [.02 kPa] for downflow air flow, for a total selection static pressure of 0.79 (0.8) in. WG [.20 kPa], and determine:

$$\text{RPM} = 739$$

$$\text{WATTS} = 2,862$$

$$\text{DRIVE} = \text{L (standard 5 H.P. motor)}$$

5. CALCULATE INDOOR BLOWER BTUH HEAT EFFECT FROM MOTOR WATTS, STEP 4.

$$2,862 \times 3.412 = 9,765 \text{ BTUH [2.86 kW]}$$

6. CALCULATE NET COOLING CAPACITIES, EQUAL TO GROSS CAPACITY, STEP 3, MINUS INDOOR BLOWER MOTOR HEAT.

$$\text{Net Total Capacity} = 235,868 - 9,765 = 226,103 \text{ BTUH [66.21 kW]}$$

$$\text{Net Sensible Capacity} = 171,314 - 9,765 = 161,549 \text{ BTUH [47.30 kW]}$$

7. CALCULATE UNIT INPUT AND JOB EER.

$$\text{Total Power Input} = 18,018 \text{ (step 3)} + 2,862 \text{ (step 4)} = 20,880 \text{ Watts}$$

$$\text{EER} = \frac{\text{Net Total BTUH [kW] (step 6)}}{\text{Power Input, Watts (above)}} = \frac{226,103}{20,880} = 10.83$$

8. SELECT UNIT HEATING CAPACITY.

From Heater Kit Table select kW to meet heating capacity requirement; multiply kW x 3412 to convert to BTUH

Use 75 kW Heater Kit
 Heater Kit Model: RXJJ-CE75C
 Heater Kit Capacity: 245,323 BTUH [71.8 kW]

Add indoor blower heat effect (step 5) to Heater Kit Capacity to get total heating capacity:

$$245,323 + 9,765 = 255,088 \text{ BTUH [74.7 kW]}$$

9. CHOOSE MODEL RLNL-H240CL075

*NOTE: These operating conditions are typical of a commercial application in a 95°F/79°F [35°C/26°C] design area with indoor design of 76°F [24°C] DB and 50% RH and 10% ventilation air, with the unit roof mounted and centered on the zone it conditions by ducts.

[] Designates Metric Conversions

NOM. SIZES 15-25 TONS [52.8-87.9 kW] MODELS

Model RLNL- Series (with VFD)	H180CR	H180CS	H180DR	H180DS
Cooling Performance¹				CONTINUED →
Gross Cooling Capacity Btu [kW]	188,000 [53.47]	188,000 [53.47]	188,000 [53.47]	188,000 [53.47]
EER	11	11	11	11
IEER ^B	14.2	14.2	14.2	14.2
Nominal CFM/AHRI Rated CFM [L/s]	6000/5900 [2831/2784]	6000/5900 [2831/2784]	6000/5900 [2831/2784]	6000/5900 [2831/2784]
AHRI Net Cooling Capacity Btu [kW]	172,000 [48.92]	172,000 [48.92]	172,000 [48.92]	172,000 [48.92]
Net Sensible Capacity Btu [kW]	125,700 [35.75]	125,700 [35.75]	125,700 [35.75]	125,700 [35.75]
Net Latent Capacity Btu [kW]	46,300 [13.17]	46,300 [13.17]	46,300 [13.17]	46,300 [13.17]
Net System Power [kW]	15.64	15.64	15.64	15.64
Compressor				
No./Type	2/Scroll	2/Scroll	2/Scroll	2/Scroll
Outdoor Sound Rating (dB)^C	91	91	91	91
Outdoor Coil—Fin Type	Louvered	Louvered	Louvered	Louvered
Tube Type	Rifled	Rifled	Rifled	Rifled
Tube Size in. [mm] OD	0.375 [9.5]	0.375 [9.5]	0.375 [9.5]	0.375 [9.5]
Face Area sq. ft. [sq. m]	53.3 [4.95]	53.3 [4.95]	53.3 [4.95]	53.3 [4.95]
Rows / FPI [FPcm]	1 / 22 [9]	1 / 22 [9]	1 / 22 [9]	1 / 22 [9]
Indoor Coil—Fin Type	Louvered	Louvered	Louvered	Louvered
Tube Type	Rifled	Rifled	Rifled	Rifled
Tube Size in. [mm]	0.375 [9.5]	0.375 [9.5]	0.375 [9.5]	0.375 [9.5]
Face Area sq. ft. [sq. m]	26.67 [2.48]	26.67 [2.48]	26.67 [2.48]	26.67 [2.48]
Rows / FPI [FPcm]	2 / 18 [7]	2 / 18 [7]	2 / 18 [7]	2 / 18 [7]
Refrigerant Control	TX Valves	TX Valves	TX Valves	TX Valves
Drain Connection No./Size in. [mm]	1/1 [25.4]	1/1 [25.4]	1/1 [25.4]	1/1 [25.4]
Outdoor Fan—Type	Propeller	Propeller	Propeller	Propeller
No. Used/Diameter in. [mm]	4/24 [609.6]	4/24 [609.6]	4/24 [609.6]	4/24 [609.6]
Drive Type/No. Speeds	Direct/1	Direct/1	Direct/1	Direct/1
CFM [L/s]	16000 [7550]	16000 [7550]	16000 [7550]	16000 [7550]
No. Motors/HP	4 at 1/3 HP	4 at 1/3 HP	4 at 1/3 HP	4 at 1/3 HP
Motor RPM	1075	1075	1075	1075
Indoor Fan—Type	FC Centrifugal	FC Centrifugal	FC Centrifugal	FC Centrifugal
No. Used/Diameter in. [mm]	2/18x9 [457x229]	2/18x9 [457x229]	2/18x9 [457x229]	2/18x9 [457x229]
Drive Type	Belt (Adjustable)	Belt (Adjustable)	Belt (Adjustable)	Belt (Adjustable)
No. Speeds (Standard / VFD)	Single / Multiple	Single / Multiple	Single / Multiple	Single / Multiple
No. Motors	1	1	1	1
Motor HP	3	5	3	5
Motor RPM	1725	1725	1725	1725
Motor Frame Size	56	184	56	184
Filter—Type	Disposable	Disposable	Disposable	Disposable
Furnished	Yes	Yes	Yes	Yes
(NO.) Size Recommended in. [mm x mm x mm]	(8)2x25x20 [51x635x508]	(8)2x25x20 [51x635x508]	(8)2x25x20 [51x635x508]	(8)2x25x20 [51x635x508]
Refrigerant Charge Oz. [g] (Sys. 1/Sys. 2) [g]	205/211 [5812/5982]	205/211 [5812/5982]	205/211 [5812/5982]	205/211 [5812/5982]
Weights				
Net Weight lbs. [kg]	1826 [828]	1855 [841]	1826 [828]	1855 [841]
Ship Weight lbs. [kg]	1952 [885]	1981 [899]	1952 [885]	1981 [899]

NOTES:

A. Cooling Performance is rated at 95° F ambient, 80° F entering dry bulb, 67° F entering wet bulb. Gross capacity does not include the effect of fan motor heat. AHRI capacity is net and includes the effect of fan motor heat. Units are suitable for operation to ±20% of nominal cfm. Units are certified in accordance with the Unitary Air Conditioner Equipment certification program, which is based on AHRI Standard 340/360.

B. EER and Integrated Energy Efficiency Ratio (IEER) are rated at AHRI conditions in accordance with AHRI Standard 340/360.

C. Outdoor Sound Rating shown is tested in accordance with AHRI Standard 270.

[] Designates Metric Conversions

NOM. SIZES 15-25 TONS [52.8-87.9 kW] MODELS

Model RLNL- Series (with VFD)	H210CR	H210CS
Cooling Performance¹		
Gross Cooling Capacity Btu [kW]	212,000 [60.30]	212,000 [60.30]
EER	11	11
IEER ^B	14	14
Nominal CFM/AHRI Rated CFM [L/s]	7000/6900 [3303/3256]	7000/6900 [3303/3256]
AHRI Net Cooling Capacity Btu [kW]	200,000 [56.88]	200,000 [56.88]
Net Sensible Capacity Btu [kW]	150,900 [42.91]	150,900 [42.91]
Net Latent Capacity Btu [kW]	49,100 [13.96]	49,100 [13.96]
Net System Power [kW]	18.18	18.18
Compressor		
No./Type	2/Scroll	2/Scroll
Outdoor Sound Rating (dB)^C		
	91	91
Outdoor Coil—Fin Type		
Tube Type	Louvered	Louvered
Tube Size in. [mm] OD	Rifled	Rifled
Face Area sq. ft. [sq. m]	0.375 [9.5]	0.375 [9.5]
Rows / FPI [FPcm]	53.3 [4.95]	53.3 [4.95]
	2 / 18 [7]	2 / 18 [7]
Indoor Coil—Fin Type		
Tube Type	Louvered	Louvered
Tube Size in. [mm]	Rifled	Rifled
Face Area sq. ft. [sq. m]	0.375 [9.5]	0.375 [9.5]
Rows / FPI [FPcm]	26.67 [2.48]	26.67 [2.48]
Refrigerant Control	2 / 18 [7]	2 / 18 [7]
Drain Connection No./Size in. [mm]	TX Valves	TX Valves
	1/1 [25.4]	1/1 [25.4]
Outdoor Fan—Type		
No. Used/Diameter in. [mm]	Propeller	Propeller
Drive Type/No. Speeds	4/24 [609.6]	4/24 [609.6]
CFM [L/s]	Direct/1	Direct/1
No. Motors/HP	14800 [6984]	14800 [6984]
Motor RPM	4 at 1/3 HP	4 at 1/3 HP
	1075	1075
Indoor Fan—Type		
No. Used/Diameter in. [mm]	FC Centrifugal	FC Centrifugal
Drive Type	2/18x9 [457x229]	2/18x9 [457x229]
No. Speeds (Standard / VFD)	Belt (Adjustable)	Belt (Adjustable)
No. Motors	Single / Multiple	Single / Multiple
Motor HP	1	1
Motor RPM	3	5
Motor Frame Size	1725	1725
	56	184
Filter—Type		
Furnished	Disposable	Disposable
(NO.) Size Recommended in. [mm x mm x mm]	Yes	Yes
	(8)2x25x20 [51x635x508]	(8)2x25x20 [51x635x508]
Refrigerant Charge Oz. [g] (Sys. 1/Sys. 2) [g]		
	294/302 [8335/8562]	294/302 [8335/8562]
Weights		
Net Weight lbs. [kg]	2013 [913]	2042 [926]
Ship Weight lbs. [kg]	2140 [971]	2160 [980]

CONTINUED →

NOTES:

A. Cooling Performance is rated at 95° F ambient, 80° F entering dry bulb, 67° F entering wet bulb. Gross capacity does not include the effect of fan motor heat. AHRI capacity is net and includes the effect of fan motor heat. Units are suitable for operation to ±20% of nominal cfm. Units are certified in accordance with the Unitary Air Conditioner Equipment certification program, which is based on AHRI Standard 340/360.

B. EER and Integrated Energy Efficiency Ratio (IEER) are rated at AHRI conditions in accordance with AHRI Standard 340/360.

C. Outdoor Sound Rating shown is tested in accordance with AHRI Standard 270.

[] Designates Metric Conversions

NOM. SIZES 15-25 TONS [52.8-87.9 kW] MODELS

Model RLNL- Series (with VFD)	H210DR	H210DS
Cooling Performance¹		
Gross Cooling Capacity Btu [kW]	212,000 [60.30]	212,000 [60.30]
EER	11	11
IEER ^B	14.2	14.2
Nominal CFM/AHRI Rated CFM [L/s]	7000/6900 [3303/3256]	7000/6900 [3303/3256]
AHRI Net Cooling Capacity Btu [kW]	200,000 [56.88]	200,000 [56.88]
Net Sensible Capacity Btu [kW]	150,900 [42.91]	150,900 [42.91]
Net Latent Capacity Btu [kW]	49,100 [13.96]	49,100 [13.96]
Net System Power [kW]	18.18	18.18
Compressor		
No./Type	2/Scroll	2/Scroll
Outdoor Sound Rating (dB)^C		
	91	91
Outdoor Coil—Fin Type		
Tube Type	Louvered	Louvered
Tube Type	Rifled	Rifled
Tube Size in. [mm] OD	0.375 [9.5]	0.375 [9.5]
Face Area sq. ft. [sq. m]	53.3 [4.95]	53.3 [4.95]
Rows / FPI [FPcm]	2 / 18 [7]	2 / 18 [7]
Indoor Coil—Fin Type		
Tube Type	Louvered	Louvered
Tube Type	Rifled	Rifled
Tube Size in. [mm]	0.375 [9.5]	0.375 [9.5]
Face Area sq. ft. [sq. m]	26.67 [2.48]	26.67 [2.48]
Rows / FPI [FPcm]	2 / 18 [7]	2 / 18 [7]
Refrigerant Control	TX Valves	TX Valves
Drain Connection No./Size in. [mm]	1/1 [25.4]	1/1 [25.4]
Outdoor Fan—Type		
No. Used/Diameter in. [mm]	4/24 [609.6]	4/24 [609.6]
Drive Type/No. Speeds	Direct/1	Direct/1
CFM [L/s]	14800 [6984]	14800 [6984]
No. Motors/HP	4 at 1/3 HP	4 at 1/3 HP
Motor RPM	1075	1075
Indoor Fan—Type		
No. Used/Diameter in. [mm]	2/18x9 [457x229]	2/18x9 [457x229]
Drive Type	Belt (Adjustable)	Belt (Adjustable)
No. Speeds (Standard / VFD)	Single / Multiple	Single / Multiple
No. Motors	1	1
Motor HP	3	5
Motor RPM	1725	1725
Motor Frame Size	56	184
Filter—Type		
Furnished	Disposable	Disposable
(NO.) Size Recommended in. [mm x mm x mm]	(8)2x25x20 [51x635x508]	(8)2x25x20 [51x635x508]
Refrigerant Charge Oz. [g] (Sys. 1/Sys. 2) [g]		
	294/302 [8335/8562]	294/302 [8335/8562]
Weights		
Net Weight lbs. [kg]	2013 [913]	2042 [926]
Ship Weight lbs. [kg]	2140 [971]	2160 [980]

CONTINUED →

NOTES:

- Cooling Performance is rated at 95° F ambient, 80° F entering dry bulb, 67° F entering wet bulb. Gross capacity does not include the effect of fan motor heat. AHRI capacity is net and includes the effect of fan motor heat. Units are suitable for operation to ±20% of nominal cfm. Units are certified in accordance with the Unitary Air Conditioner Equipment certification program, which is based on AHRI Standard 340/360.
- EER and Integrated Energy Efficiency Ratio (IEER) are rated at AHRI conditions in accordance with AHRI Standard 340/360.
- Outdoor Sound Rating shown is tested in accordance with AHRI Standard 270.

[] Designates Metric Conversions

NOM. SIZES 15-25 TONS [52.8-87.9 kW] MODELS

Model RLNL- Series (with VFD)	H240CR	H240CS	H240CT	H240DR
Cooling Performance¹				CONTINUED →
Gross Cooling Capacity Btu [kW]	244,000 [69.40]	244,000 [69.40]	244,000 [69.40]	244,000 [69.40]
EER	11	11	11	11
IEER ^B	14.2	14.2	14.2	14.2
Nominal CFM/AHRI Rated CFM [L/s]	8000/7725 [3775/3645]	8000/7725 [3775/3645]	8000/7725 [3775/3645]	8000/7725 [3775/3645]
AHRI Net Cooling Capacity Btu [kW]	228,000 [64.85]	228,000 [64.85]	228,000 [64.85]	228,000 [64.85]
Net Sensible Capacity Btu [kW]	165,600 [47.10]	165,600 [47.10]	165,600 [47.10]	165,600 [47.10]
Net Latent Capacity Btu [kW]	62,400 [17.75]	62,400 [17.75]	62,400 [17.75]	62,400 [17.75]
Net System Power [kW]	20.73	20.73	20.73	20.73
Compressor				
No./Type	2/Scroll	2/Scroll	2/Scroll	2/Scroll
Outdoor Sound Rating (dB)^C	91	91	91	91
Outdoor Coil—Fin Type	Louvered	Louvered	Louvered	Louvered
Tube Type	Rifled	Rifled	Rifled	Rifled
Tube Size in. [mm] OD	0.375 [9.5]	0.375 [9.5]	0.375 [9.5]	0.375 [9.5]
Face Area sq. ft. [sq. m]	53.3 [4.95]	53.3 [4.95]	53.3 [4.95]	53.3 [4.95]
Rows / FPI [FPcm]	2 / 22 [9]	2 / 22 [9]	2 / 22 [9]	2 / 22 [9]
Indoor Coil—Fin Type	Louvered	Louvered	Louvered	Louvered
Tube Type	Rifled	Rifled	Rifled	Rifled
Tube Size in. [mm]	0.375 [9.5]	0.375 [9.5]	0.375 [9.5]	0.375 [9.5]
Face Area sq. ft. [sq. m]	26.67 [2.48]	26.67 [2.48]	26.67 [2.48]	26.67 [2.48]
Rows / FPI [FPcm]	3 / 13 [5]	3 / 13 [5]	3 / 13 [5]	3 / 13 [5]
Refrigerant Control	TX Valves	TX Valves	TX Valves	TX Valves
Drain Connection No./Size in. [mm]	1/1 [25.4]	1/1 [25.4]	1/1 [25.4]	1/1 [25.4]
Outdoor Fan—Type	Propeller	Propeller	Propeller	Propeller
No. Used/Diameter in. [mm]	6/24 [609.6]	6/24 [609.6]	6/24 [609.6]	6/24 [609.6]
Drive Type/No. Speeds	Direct/1	Direct/1	Direct/1	Direct/1
CFM [L/s]	19800 [9344]	19800 [9344]	19800 [9344]	19800 [9344]
No. Motors/HP	6 at 1/3 HP	6 at 1/3 HP	6 at 1/3 HP	6 at 1/3 HP
Motor RPM	1075	1075	1075	1075
Indoor Fan—Type	FC Centrifugal	FC Centrifugal	FC Centrifugal	FC Centrifugal
No. Used/Diameter in. [mm]	2/18x9 [457x229]	2/18x9 [457x229]	2/18x9 [457x229]	2/18x9 [457x229]
Drive Type	Belt (Adjustable)	Belt (Adjustable)	Belt (Adjustable)	Belt (Adjustable)
No. Speeds (Standard / VFD)	Single / Multiple	Single / Multiple	Single / Multiple	Single / Multiple
No. Motors	1	1	1	1
Motor HP	5	7 1/2	7 1/2	5
Motor RPM	1725	1725	1725	1725
Motor Frame Size	184	213	213	184
Filter—Type	Disposable	Disposable	Disposable	Disposable
Furnished	Yes	Yes	Yes	Yes
(NO.) Size Recommended in. [mm x mm x mm]	(8)2x25x20 [51x635x508]	(8)2x25x20 [51x635x508]	(8)2x25x20 [51x635x508]	(8)2x25x20 [51x635x508]
Refrigerant Charge Oz. [g] (Sys. 1/Sys. 2) [g]	402/331 [11397/9384]	402/331 [11397/9384]	402/331 [11397/9384]	402/331 [11397/9384]
Weights				
Net Weight lbs. [kg]	2151 [976]	2189 [993]	2187 [992]	2151 [976]
Ship Weight lbs. [kg]	2277 [1033]	2315 [1050]	2314 [1050]	2277 [1033]

NOTES:

- Cooling Performance is rated at 95° F ambient, 80° F entering dry bulb, 67° F entering wet bulb. Gross capacity does not include the effect of fan motor heat. AHRI capacity is net and includes the effect of fan motor heat. Units are suitable for operation to ±20% of nominal cfm. Units are certified in accordance with the Unitary Air Conditioner Equipment certification program, which is based on AHRI Standard 340/360.
- EER and Integrated Energy Efficiency Ratio (IEER) are rated at AHRI conditions in accordance with AHRI Standard 340/360.
- Outdoor Sound Rating shown is tested in accordance with AHRI Standard 270.

[] Designates Metric Conversions

NOM. SIZES 15-25 TONS [52.8-87.9 kW] MODELS

Model RLNL- Series (with VFD)	H240DS	H240DT
Cooling Performance¹		
Gross Cooling Capacity Btu [kW]	244,000 [69.40]	244,000 [69.40]
EER	11	11
IEER ^B	14.2	14.2
Nominal CFM/AHRI Rated CFM [L/s]	8000/7725 [3775/3645]	8000/7725 [3775/3645]
AHRI Net Cooling Capacity Btu [kW]	228,000 [64.85]	228,000 [64.85]
Net Sensible Capacity Btu [kW]	165,600 [47.10]	165,600 [47.10]
Net Latent Capacity Btu [kW]	62,400 [17.75]	62,400 [17.75]
Net System Power [kW]	20.73	20.73
Compressor		
No./Type	2/Scroll	2/Scroll
Outdoor Sound Rating (dB)^C		
	91	91
Outdoor Coil—Fin Type		
Tube Type	Louvered	Louvered
Tube Type	Rifled	Rifled
Tube Size in. [mm] OD	0.375 [9.5]	0.375 [9.5]
Face Area sq. ft. [sq. m]	53.3 [4.95]	53.3 [4.95]
Rows / FPI [FPcm]	2 / 22 [9]	2 / 22 [9]
Indoor Coil—Fin Type		
Tube Type	Louvered	Louvered
Tube Type	Rifled	Rifled
Tube Size in. [mm]	0.375 [9.5]	0.375 [9.5]
Face Area sq. ft. [sq. m]	26.67 [2.48]	26.67 [2.48]
Rows / FPI [FPcm]	3 / 13 [5]	3 / 13 [5]
Refrigerant Control	TX Valves	TX Valves
Drain Connection No./Size in. [mm]	1/1 [25.4]	1/1 [25.4]
Outdoor Fan—Type		
No. Used/Diameter in. [mm]	6/24 [609.6]	6/24 [609.6]
Drive Type/No. Speeds	Direct/1	Direct/1
CFM [L/s]	19800 [9344]	19800 [9344]
No. Motors/HP	6 at 1/3 HP	6 at 1/3 HP
Motor RPM	1075	1075
Indoor Fan—Type		
No. Used/Diameter in. [mm]	2/18x9 [457x229]	2/18x9 [457x229]
Drive Type	Belt (Adjustable)	Belt (Adjustable)
No. Speeds (Standard / VFD)	Single / Multiple	Single / Multiple
No. Motors	1	1
Motor HP	7 1/2	7 1/2
Motor RPM	1725	1725
Motor Frame Size	184	184
Filter—Type		
Furnished	Disposable	Disposable
(NO.) Size Recommended in. [mm x mm x mm]	(8)2x25x20 [51x635x508]	(8)2x25x20 [51x635x508]
Refrigerant Charge Oz. [g] (Sys. 1/Sys. 2) [g]		
	402/331 [11397/9384]	402/331 [11397/9384]
Weights		
Net Weight lbs. [kg]	2189 [993]	2187 [992]
Ship Weight lbs. [kg]	2315 [1050]	2314 [1050]

CONTINUED →

NOTES:

- Cooling Performance is rated at 95° F ambient, 80° F entering dry bulb, 67° F entering wet bulb. Gross capacity does not include the effect of fan motor heat. AHRI capacity is net and includes the effect of fan motor heat. Units are suitable for operation to ±20% of nominal cfm. Units are certified in accordance with the Unitary Air Conditioner Equipment certification program, which is based on AHRI Standard 340/360.
- EER and Integrated Energy Efficiency Ratio (IEER) are rated at AHRI conditions in accordance with AHRI Standard 340/360.
- Outdoor Sound Rating shown is tested in accordance with AHRI Standard 270.

[] Designates Metric Conversions

NOM. SIZES 15-25 TONS [52.8-87.9 kW] MODELS

Model RLNL- Series (with VFD)	H300CR	H300CS	H300DR	H300DS
Cooling Performance¹				
Gross Cooling Capacity Btu [kW]	312000 [88.74]	312000 [88.74]	312000 [88.74]	312,000 [88.74]
EER	10	10	10	10
IEER ^B	13	13	13	13
Nominal CFM/AHRI Rated CFM [L/s]	10000/9700 [4719/4577]	10000/9700 [4719/4577]	10000/9700 [4719/4577]	10000/9700 [4719/4577]
AHRI Net Cooling Capacity Btu [kW]	290,000 [84.99]	290,000 [84.99]	290,000 [84.99]	290,000 [84.99]
Net Sensible Capacity Btu [kW]	208,900 [61.22]	208,900 [61.22]	208,900 [61.22]	208,900 [61.22]
Net Latent Capacity Btu [kW]	81,100 [23.76]	81,100 [23.76]	81,100 [23.76]	81,100 [23.76]
Net System Power [kW]	29	29	29	29
Compressor				
No./Type	2/Scroll	2/Scroll	2/Scroll	2/Scroll
Outdoor Sound Rating (dB)^C				
	92	92	92	92
Outdoor Coil—Fin Type				
Tube Type	Louvered	Louvered	Louvered	Louvered
Tube Type	Rifled	Rifled	Rifled	Rifled
Tube Size in. [mm] OD	0.375 [9.5]	0.375 [9.5]	0.375 [9.5]	0.375 [9.5]
Face Area sq. ft. [sq. m]	53.3 [4.95]	53.3 [4.95]	53.3 [4.95]	53.3 [4.95]
Rows / FPI [FPcm]	53.3 [4.95]	2 / 22 [9]	2 / 22 [9]	2 / 22 [9]
Indoor Coil—Fin Type				
Tube Type	Louvered	Louvered	Louvered	Louvered
Tube Type	Rifled	Rifled	Rifled	Rifled
Tube Size in. [mm]	0.375 [9.5]	0.375 [9.5]	0.375 [9.5]	0.375 [9.5]
Face Area sq. ft. [sq. m]	26.67 [2.48]	26.67 [2.48]	26.67 [2.48]	26.67 [2.48]
Rows / FPI [FPcm]	4 / 15 [6]	4 / 15 [6]	4 / 15 [6]	4 / 15 [6]
Refrigerant Control	TX Valves	TX Valves	TX Valves	TX Valves
Drain Connection No./Size in. [mm]	1/1 [25.4]	1/1 [25.4]	1/1 [25.4]	1/1 [25.4]
Outdoor Fan—Type				
No. Used/Diameter in. [mm]	Propeller	Propeller	Propeller	Propeller
Drive Type/No. Speeds	6/24 [609.6]	6/24 [609.6]	6/24 [609.6]	6/24 [609.6]
CFM [L/s]	Direct/1	Direct/1	Direct/1	Direct/1
No. Motors/HP	19800 [9344]	19800 [9344]	19800 [9344]	19800 [9344]
Motor RPM	6 at 1/3 HP	6 at 1/3 HP	6 at 1/3 HP	6 at 1/3 HP
	1075	1075	1075	1075
Indoor Fan—Type				
No. Used/Diameter in. [mm]	FC Centrifugal	FC Centrifugal	FC Centrifugal	FC Centrifugal
Drive Type	2/18x9 [457x229]	2/18x9 [457x229]	2/18x9 [457x229]	2/18x9 [457x229]
No. Speeds (Standard / VFD)	Belt (Adjustable)	Belt (Adjustable)	Belt (Adjustable)	Belt (Adjustable)
No. Motors	Single / Multiple	Single / Multiple	Single / Multiple	Single / Multiple
Motor HP	1	1	1	1
Motor RPM	7 1/2	10	7 1/2	10
Motor Frame Size	1725	1725	1725	1725
	213	215	213	215
Filter—Type				
Furnished	Disposable	Disposable	Disposable	Disposable
(NO.) Size Recommended in. [mm x mm x mm]	Yes	Yes	Yes	Yes
	(8)2x25x20 [51x635x508]	(8)2x25x20 [51x635x508]	(8)2x25x20 [51x635x508]	(8)2x25x20 [51x635x508]
Refrigerant Charge Oz. [g] (Sys. 1/Sys. 2) [g]				
	339/357 [9611/10121]	339/357 [9611/10121]	339/357 [9611/10121]	339/357 [9611/10121]
Weights				
Net Weight lbs. [kg]	2250 [1021]	2261 [1026]	2250 [1021]	2261 [1026]
Ship Weight lbs. [kg]	2376 [1078]	2387 [1083]	2376 [1078]	2387 [1083]

NOTES:

A. Cooling Performance is rated at 95° F ambient, 80° F entering dry bulb, 67° F entering wet bulb. Gross capacity does not include the effect of fan motor heat. AHRI capacity is net and includes the effect of fan motor heat. Units are suitable for operation to ±20% of nominal cfm. Units are certified in accordance with the Unitary Air Conditioner Equipment certification program, which is based on AHRI Standard 340/360.

B. EER and Integrated Energy Efficiency Ratio (IEER) are rated at AHRI conditions in accordance with AHRI Standard 340/360.

C. Outdoor Sound Rating shown is tested in accordance with AHRI Standard 270.

[] Designates Metric Conversions

GROSS SYSTEMS PERFORMANCE DATA—H240

ENTERING INDOOR AIR @ 80°F [26.7°C] dbE ①											
wbE		71°F [21.7°C]			67°F [19.4°C]			63°F [17.2°C]			
CFM [L/s]		9600 [4530]	7725 [3646]	6400 [3020]	9600 [4530]	7725 [3646]	6400 [3020]	9600 [4530]	7725 [3646]	6400 [3020]	
DR ①		.06	.11	.15	.06	.11	.15	.06	.11	.15	
OUTDOOR DRY BULB TEMPERATURE °F [°C]	75 [23.9]	Total BTUH [kW]	283.5 [83.1]	271.5 [79.6]	263.0 [77.1]	269.6 [79.0]	258.2 [75.7]	250.2 [73.3]	258.7 [75.8]	247.8 [72.6]	240.0 [70.3]
		Sens BTUH [kW]	187.4 [54.9]	156.3 [45.8]	136.0 [39.9]	220.5 [64.6]	186.7 [54.7]	164.4 [48.2]	245.6 [72.0]	209.7 [61.5]	185.7 [54.4]
		Power	15.4	15.1	14.9	15.3	15.0	14.7	15.1	14.8	14.6
	80 [26.7]	Total BTUH [kW]	280.8 [82.3]	269.0 [78.8]	260.6 [76.4]	267.0 [78.2]	255.7 [74.9]	247.7 [72.6]	256.1 [75.1]	245.3 [71.9]	237.6 [69.6]
		Sens BTUH [kW]	186.4 [54.6]	155.6 [45.6]	135.4 [39.7]	219.6 [64.4]	186.0 [54.5]	163.8 [48.0]	244.7 [71.7]	209.0 [61.3]	185.2 [54.3]
		Power	16.2	15.9	15.6	16.0	15.7	15.5	15.9	15.5	15.3
	85 [29.4]	Total BTUH [kW]	277.4 [81.3]	265.7 [77.9]	257.4 [75.4]	263.5 [77.2]	252.4 [74.0]	244.5 [71.7]	252.6 [74.0]	242.0 [70.9]	234.4 [68.7]
		Sens BTUH [kW]	184.9 [54.2]	154.4 [45.3]	134.4 [39.4]	218.1 [63.9]	184.8 [54.2]	162.7 [47.7]	243.1 [71.3]	207.8 [60.9]	184.2 [54.0]
		Power	17.0	16.7	16.4	16.9	16.5	16.3	16.7	16.3	16.1
	90 [32.2]	Total BTUH [kW]	273.1 [80.0]	261.6 [76.7]	253.4 [74.3]	259.3 [76.0]	248.3 [72.8]	240.6 [70.5]	248.4 [72.8]	237.9 [69.7]	230.5 [67.6]
Sens BTUH [kW]		182.8 [53.6]	152.7 [44.8]	132.9 [39.0]	216.2 [63.4]	183.2 [53.7]	161.5 [47.3]	241.1 [70.7]	206.1 [60.4]	182.8 [53.6]	
Power		17.9	17.5	17.3	17.7	17.4	17.1	17.6	17.2	16.9	
95 [35]	Total BTUH [kW]	268.1 [78.6]	256.7 [75.2]	248.7 [72.9]	254.2 [74.5]	243.5 [71.4]	235.9 [69.1]	243.3 [71.3]	233.0 [68.3]	225.8 [66.2]	
	Sens BTUH [kW]	180.2 [52.8]	150.5 [44.1]	131.1 [38.4]	213.5 [62.6]	181.1 [53.1]	159.6 [46.8]	238.6 [69.9]	204.0 [59.8]	181.0 [53.1]	
	Power	18.8	18.4	18.2	18.7	18.3	18.0	18.5	18.1	17.8	
100 [37.8]	Total BTUH [kW]	262.2 [76.8]	251.1 [73.6]	243.3 [71.3]	248.3 [72.8]	237.8 [69.7]	230.4 [67.5]	237.4 [69.6]	227.4 [66.6]	220.3 [64.6]	
	Sens BTUH [kW]	177.1 [51.9]	148.0 [43.4]	129.0 [37.8]	210.4 [61.7]	178.5 [52.3]	157.4 [46.1]	235.3 [69.0]	201.4 [59.0]	178.7 [52.4]	
	Power	19.8	19.4	19.1	19.6	19.2	18.9	19.5	19.1	18.8	
105 [40.6]	Total BTUH [kW]	255.5 [74.9]	244.7 [71.7]	237.1 [69.5]	241.6 [70.8]	231.4 [67.8]	224.2 [65.7]	230.7 [67.6]	221.0 [64.8]	214.1 [62.7]	
	Sens BTUH [kW]	173.4 [50.8]	145.0 [42.5]	126.4 [37.1]	206.6 [60.6]	175.4 [51.4]	154.7 [45.3]	230.7 [67.6]	198.4 [58.2]	176.2 [51.6]	
	Power	20.8	20.4	20.1	20.7	20.2	19.9	20.5	20.1	19.8	
110 [43.3]	Total BTUH [kW]	248.0 [72.7]	237.5 [69.6]	230.1 [67.4]	234.1 [68.6]	224.2 [65.7]	217.2 [63.7]	223.2 [65.4]	213.8 [62.7]	207.1 [60.7]	
	Sens BTUH [kW]	169.2 [49.6]	141.5 [41.5]	123.4 [36.2]	202.4 [59.3]	171.9 [50.4]	151.7 [44.5]	223.2 [65.4]	194.9 [57.1]	173.1 [50.7]	
	Power	21.9	21.5	21.1	21.7	21.3	21.0	21.6	21.1	20.8	
115 [46.1]	Total BTUH [kW]	239.6 [70.2]	229.5 [67.3]	222.3 [65.1]	225.8 [66.2]	216.2 [63.4]	209.5 [61.4]	214.9 [63.0]	205.8 [60.3]	199.4 [58.4]	
	Sens BTUH [kW]	164.3 [48.2]	137.5 [40.3]	119.9 [35.1]	197.7 [58.0]	168.0 [49.2]	148.4 [43.5]	214.9 [63.0]	191.0 [56.0]	169.8 [49.8]	
	Power	23.1	22.6	22.2	22.9	22.4	22.1	22.7	22.2	21.9	

DR —Depression ratio
dbE —Entering air dry bulb
wbE—Entering air wet bulb

Total —Total capacity x 1000 BTUH
Sens —Sensible capacity x 1000 BTUH
Power —KW input

NOTES: ① When the entering air dry bulb is other than 80°F [27°C], adjust the sensible capacity from the table by adding [1.10 x CFM x (1 – DR) x (dbE – 80)].

[] Designates Metric Conversions

GROSS SYSTEMS PERFORMANCE DATA—H300

		ENTERING INDOOR AIR @ 80°F [26.7°C] dbE ①									
		71°F [21.7°C]			67°F [19.4°C]			63°F [17.2°C]			
wbE		12000 [5663]	9475 [4472]	8000 [3776]	12000 [5663]	9475 [4472]	8000 [3776]	12000 [5663]	9475 [4472]	8000 [3776]	
CFM [L/s]		12000 [5663]	9475 [4472]	8000 [3776]	12000 [5663]	9475 [4472]	8000 [3776]	12000 [5663]	9475 [4472]	8000 [3776]	
DR ①		.02	.08	.11	.02	.08	.11	.02	.08	.11	
OUTDOOR DRY BULB TEMPERATURE °F [°C]	75 [23.9]	Total BTUH [kW] Sens BTUH [kW] Power	376.4 [110.3] 251.6 [73.7] 20.8	359.0 [105.2] 206.4 [60.5] 20.3	348.9 [102.3] 182.0 [53.3] 20.0	358.0 [104.9] 294.2 [86.2] 20.5	341.5 [100.1] 245.2 [71.9] 20.0	331.8 [97.2] 218.4 [64.0] 19.7	347.0 [101.7] 326.2 [95.6] 20.2	330.9 [97.0] 274.0 [80.3] 19.7	321.6 [94.3] 245.5 [72.0] 19.5
	80 [26.7]	Total BTUH [kW] Sens BTUH [kW] Power	369.9 [108.4] 248.1 [72.7] 21.7	352.8 [103.4] 203.6 [59.7] 21.2	342.8 [100.5] 179.5 [52.6] 21.0	351.5 [103.0] 290.8 [85.2] 21.4	335.2 [98.2] 242.3 [71.0] 21.0	325.7 [95.5] 215.9 [63.3] 20.7	340.4 [99.8] 322.6 [94.6] 21.2	324.6 [95.1] 271.1 [79.5] 20.7	315.5 [92.5] 243.0 [71.2] 20.4
	85 [29.4]	Total BTUH [kW] Sens BTUH [kW] Power	362.5 [106.2] 244.2 [71.6] 22.8	345.7 [101.3] 200.4 [58.7] 22.2	335.9 [98.4] 176.8 [51.8] 21.9	344.1 [100.8] 286.8 [84.1] 22.5	328.2 [96.2] 239.2 [70.1] 22.0	318.9 [93.5] 213.2 [62.5] 21.7	333.0 [97.6] 318.6 [93.4] 22.2	317.6 [93.1] 268.0 [78.6] 21.7	308.6 [90.4] 240.2 [70.4] 21.4
	90 [32.2]	Total BTUH [kW] Sens BTUH [kW] Power	354.3 [103.8] 239.8 [70.3] 23.9	338.0 [99.1] 197.0 [57.7] 23.3	328.4 [96.2] 173.8 [50.9] 23.0	335.9 [98.4] 282.4 [82.8] 23.6	320.4 [93.9] 235.7 [69.1] 23.0	311.3 [91.2] 210.1 [61.6] 22.7	324.9 [95.2] 314.4 [92.2] 23.3	309.8 [90.8] 264.5 [77.5] 22.7	301.1 [88.2] 237.2 [69.5] 22.4
	95 [35]	Total BTUH [kW] Sens BTUH [kW] Power	345.4 [101.2] 235.2 [68.9] 25.0	329.4 [96.5] 193.2 [56.6] 24.4	320.1 [93.8] 170.5 [50.0] 24.1	327.0 [95.8] 277.8 [81.4] 24.7	311.9 [91.4] 232.0 [68.0] 24.1	303.1 [88.8] 207.0 [60.7] 23.8	315.9 [92.6] 309.7 [90.8] 24.4	301.3 [88.3] 260.8 [76.4] 23.9	292.8 [85.8] 234.0 [68.6] 23.5
	100 [37.8]	Total BTUH [kW] Sens BTUH [kW] Power	335.7 [98.4] 230.3 [67.5] 26.2	320.2 [93.8] 189.3 [55.5] 25.6	311.1 [91.2] 167.1 [49.0] 25.3	317.3 [93.0] 272.9 [80.0] 25.9	302.6 [88.7] 228.0 [66.8] 25.3	294.1 [86.2] 203.6 [59.7] 25.0	306.2 [89.7] 304.7 [89.3] 25.6	292.1 [85.6] 256.9 [75.3] 25.1	283.8 [83.2] 230.5 [67.6] 24.7
	105 [40.6]	Total BTUH [kW] Sens BTUH [kW] Power	325.2 [95.3] 224.9 [65.9] 27.5	310.2 [90.9] 185.0 [54.2] 26.9	301.4 [88.3] 163.4 [47.9] 26.5	306.8 [89.9] 267.5 [78.4] 27.2	292.6 [85.8] 223.7 [65.6] 26.6	284.3 [83.3] 199.8 [58.6] 26.2	295.7 [86.7] 295.7 [86.7] 26.9	282.0 [82.6] 252.5 [74.0] 26.3	274.1 [80.3] 226.8 [66.5] 25.9
	110 [43.3]	Total BTUH [kW] Sens BTUH [kW] Power	313.9 [92.0] 219.3 [64.3] 28.9	299.4 [87.7] 180.5 [52.9] 28.2	290.9 [85.3] 159.5 [46.8] 27.8	295.5 [86.6] 261.9 [76.8] 28.6	281.9 [82.6] 219.3 [64.3] 27.9	273.9 [80.3] 195.9 [57.4] 27.5	284.4 [83.3] 284.4 [83.4] 28.3	271.3 [79.5] 248.1 [72.7] 27.6	263.6 [77.3] 222.9 [65.3] 27.2
	115 [46.1]	Total BTUH [kW] Sens BTUH [kW] Power	301.8 [88.4] 213.2 [62.5] 30.3	287.9 [84.4] 175.7 [51.5] 29.6	279.7 [82.0] 155.3 [45.5] 29.2	283.4 [83.1] 255.8 [75.0] 30.0	270.4 [79.2] 214.5 [62.9] 29.3	262.7 [77.0] 191.8 [56.2] 28.9	272.4 [79.8] 272.4 [79.8] 29.7	259.8 [76.1] 243.3 [71.3] 29.0	252.4 [74.0] 218.8 [64.1] 28.6

DR —Depression ratio
dbE —Entering air dry bulb
wbE—Entering air wet bulb

Total —Total capacity x 1000 BTUH
Sens —Sensible capacity x 1000 BTUH
Power —KW input

NOTES: ① When the entering air dry bulb is other than 80°F [27°C], adjust the sensible capacity from the table by adding [1.10 x CFM x (1 – DR) x (dbE – 80)].

[] Designates Metric Conversions

AIRFLOW PERFORMANCE— 15 TON [52.8 kW]—SIDEFLOW

Air Flow CFM (L/s)	Capacity 15 Ton [52.8 kW] Voltage 208/230, 460, 575 — 3 Phase																																							
	External Static Pressure—Inches of Water [kPa]																																							
	0.1 [0.2]	0.2 [0.05]	0.3 [0.07]	0.4 [0.10]	0.5 [0.12]	0.6 [0.15]	0.7 [0.17]	0.8 [0.20]	0.9 [0.22]	1.0 [0.25]	1.1 [0.27]	1.2 [0.30]	1.3 [0.32]	1.4 [0.35]	1.5 [0.37]	1.6 [0.40]	1.7 [0.42]	1.8 [0.45]	1.9 [0.47]	2.0 [0.50]																				
4800 [2265]	—	—	—	—	—	583	1393	608	1508	632	1621	656	1732	679	1841	701	1947	723	2052	744	2154	764	2254	785	2326	805	2430	825	2537	844	2647	863	2761	881	2878					
5000 [2359]	—	—	—	—	—	591	1476	616	1593	640	1707	663	1820	686	1930	708	2038	729	2145	750	2248	771	2350	791	2420	811	2528	830	2640	850	2755	868	2873	887	2995					
5200 [2454]	—	—	—	—	575	1442	600	1562	624	1681	648	1797	671	1911	693	2023	715	2133	736	2241	757	2346	777	2410	797	2520	817	2633	836	2749	855	2869	874	2992	892	3118				
5400 [2548]	—	—	—	—	583	1530	608	1652	632	1772	655	1890	678	2005	701	2119	722	2231	743	2340	764	2447	784	2512	804	2626	823	2744	842	2865	861	2989	879	3117	897	3248				
5600 [2643]	—	—	—	—	592	1621	616	1745	640	1866	663	1986	686	2103	708	2218	729	2331	750	2442	770	2551	791	2620	810	2739	830	2861	849	2987	867	3116	885	3248	903	3384				
5800 [2737]	—	—	—	576	1588	601	1715	625	1840	649	1964	672	2085	694	2204	716	2321	737	2436	757	2548	778	2614	798	2735	817	2858	836	2985	855	3116	873	3249	891	3386	909	3527			
6000 [2831]	—	—	—	585	1683	610	1813	634	1940	657	2065	680	2187	702	2308	724	2426	744	2543	765	2657	785	2731	805	2856	824	2984	843	3116	861	3251	879	3389	897	3531	914	3676			
6200 [2926]	—	—	—	570	1650	595	1783	619	1913	643	2042	666	2169	688	2293	710	2415	731	2535	752	2653	773	2728	792	2854	812	2984	831	3116	850	3253	868	3392	886	3535	903	3682	920	3832	
6400 [3020]	—	—	—	579	1750	604	1885	628	2017	652	2148	674	2276	697	2402	718	2526	739	2648	760	2767	780	2852	800	2983	819	3118	838	3255	856	3396	875	3541	892	3688	909	3839	926	3994	
6600 [3114]	—	—	—	589	1854	614	1991	637	2125	661	2257	683	2386	705	2514	727	2640	748	2763	768	2884	788	2984	808	3119	827	3258	845	3400	863	3546	881	3695	899	3847	916	4003	—	—	
6800 [3209]	—	—	574	1822	599	1961	623	2099	647	2235	670	2369	692	2500	714	2629	735	2756	756	2882	776	2984	796	3121	815	3262	834	3405	853	3552	871	3702	888	3856	905	4013	922	4173	—	—
7000 [3303]	—	—	584	1930	609	2072	633	2211	656	2349	679	2484	701	2617	723	2748	744	2877	764	3003	785	3124	804	3265	823	3410	842	3559	860	3710	878	3865	895	4024	912	4185	929	4350	—	—
7200 [3398]	570	1897	595	2042	619	2185	643	2327	666	2466	689	2602	711	2737	732	2870	753	3000	773	3127	793	3270	812	3416	831	3566	849	3719	868	3875	885	4035	902	4198	919	4364	—	—	—	—

NOTE: L-Drive left of bold line, M-Drive right of bold line.

Drive Package	L, R						M, S																																						
Motor H.P. [W]	3.0 [2237.1]						5.0 [3728.5]																																						
Blower Sheave	BK105H						BK105H																																						
Motor Sheave	1VL-44						1VP-56																																						
Turns Open	1	2	3	4	5	6	1	2	3	4	5	6	1	2	3	4	5	6	1	2	3	4	5	6	1	2	3	4	5	6	1	2	3	4	5	6									
RPM	733	701	669	640	605	572	927	903	873	840	808	775	808	783	758	733	708	683	658	633	608	583	558	533	508	483	458	433	408	383	358	333	308	283	258	233	208	183	158	133	108	83	58	33	8

NOTES: 1. Factory sheave settings are shown in bold type.
2. Do not set motor sheave below minimum turns open shown.
3. Re-adjustment of sheave required to achieve rated airflow at AHRI minimum External Static Pressure.
4. Drive data shown is for horizontal airflow with dry coil. Add component resistance (below) to duct resistance to determine total External Static Pressure.

[] Designates Metric Conversions

COMPONENT AIR RESISTANCE — 15 TON [52.8 kW]

CFM [L/s]	4800	5000	5200	5400	5600	5800	6000	6200	6400	6600	6800	7000	7200
	[2265]	[2360]	[2454]	[2549]	[2643]	[2737]	[2832]	[2926]	[3020]	[3115]	[3209]	[3304]	[3398]
Resistance — Inches of Water [kPa]													
Wet Coil	0.03 [0.01]	0.04 [0.01]	0.05 [0.01]	0.06 [0.01]	0.06 [0.01]	0.07 [0.02]	0.08 [0.02]	0.09 [0.02]	0.10 [0.02]	0.10 [0.02]	0.11 [0.03]	0.12 [0.03]	0.13 [0.03]
Downflow	0.05 [0.01]	0.05 [0.01]	0.05 [0.01]	0.05 [0.01]	0.05 [0.01]	0.05 [0.01]	0.06 [0.01]	0.06 [0.01]	0.06 [0.01]	0.06 [0.01]	0.07 [0.02]	0.08 [0.02]	0.08 [0.02]
Downflow Economizer R.A. Damper Open	0.09 [0.02]	0.10 [0.02]	0.10 [0.02]	0.11 [0.03]	0.12 [0.03]	0.13 [0.03]	0.13 [0.03]	0.14 [0.03]	0.15 [0.04]	0.16 [0.04]	0.16 [0.04]	0.17 [0.04]	0.18 [0.04]
Horizontal Economizer R.A. Damper Open	0.00 [0.00]	0.01 [0.00]	0.01 [0.00]	0.02 [0.00]	0.02 [0.00]	0.03 [0.01]	0.03 [0.01]	0.04 [0.01]	0.04 [0.01]	0.05 [0.01]	0.05 [0.01]	0.06 [0.01]	0.06 [0.01]
Concentric Grill RXRN-AD80 or RXRN-AD81 & Transition RXMC-CJ07	0.21 [0.05]	0.25 [0.06]	0.28 [0.07]	0.32 [0.08]	0.35 [0.09]	0.39 [0.10]	0.43 [0.11]	0.46 [0.11]	0.50 [0.12]	0.54 [0.13]	0.57 [0.14]	0.61 [0.15]	0.64 [0.16]
Pressure Drop MERV 8	0.068 [0.02]	0.072 [0.02]	0.076 [0.02]	0.08 [0.02]	0.084 [0.02]	0.088 [0.02]	0.092 [0.02]	0.096 [0.02]	0.1 [0.02]	0.104 [0.02]	0.108 [0.03]	0.112 [0.03]	0.116 [0.03]
Pressure Drop MERV 13	0.009 [0.00]	0.015 [0.00]	0.021 [0.00]	0.028 [0.01]	0.034 [0.01]	0.04 [0.01]	0.046 [0.01]	0.052 [0.01]	0.058 [0.01]	0.065 [0.02]	0.071 [0.02]	0.077 [0.02]	0.083 [0.02]

NOTE: Add component resistance to duct resistance to determine total external static pressure.

AIRFLOW CORRECTION FACTORS — 15 TON [52.8 kW]

ACTUAL—CFM [L/s]	4800 [2265]	5000 [2360]	5200 [2454]	5400 [2549]	5600 [2643]	5800 [2737]	6000 [2832]	6200 [2926]	6400 [3020]	6600 [3115]	6800 [3209]	7000 [3304]	7200 [3398]
TOTAL MBTUH	0.97	0.97	0.98	0.98	0.99	0.99	1.00	1.01	1.02	1.02	1.03	1.03	1.04
SENSIBLE MBTUH	0.87	0.90	0.92	0.94	0.97	0.99	1.02	1.04	1.06	1.09	1.11	1.14	1.16
POWER KW	0.98	0.98	0.99	0.99	0.99	1.00	1.00	1.00	1.01	1.01	1.01	1.02	1.02

NOTES: Multiply correction factor times gross performance data—resulting sensible capacity cannot exceed total capacity.

[] Designates Metric Conversions

AIRFLOW PERFORMANCE — 17.5 TON [61.5 kW]—SIDEFLOW

Air Flow CFM [L/s]	Capacity 17.5 Ton [61.5 kW] Voltage 208/230, 460, 575 — 3 Phase																																						
	External Static Pressure—Inches of Water [kPa]																																						
	0.1 [0.02]	0.2 [0.05]	0.3 [0.07]	0.4 [0.10]	0.5 [0.12]	0.6 [0.15]	0.7 [0.17]	0.8 [0.20]	0.9 [0.22]	1.0 [0.25]	1.1 [0.27]	1.2 [0.30]	1.3 [0.32]	1.4 [0.35]	1.5 [0.37]	1.6 [0.40]	1.7 [0.42]	1.8 [0.45]	1.9 [0.47]	2.0 [0.50]	W	RPM	W	RPM	W	RPM	W	RPM	W	RPM	W	RPM	W	RPM	W	RPM	W	RPM	W
5600 [2643]	—	—	—	599	1627	625	1762	651	1900	676	2042	701	2186	725	2334	749	2484	773	2638	796	2795	819	2955	841	3119	863	3285	885	3455	906	3628	927	3803	—	—	—	—		
5800 [2737]	—	—	—	610	1719	635	1856	661	1996	685	2140	710	2286	734	2436	757	2588	780	2744	803	2903	825	3065	847	3230	869	3399	890	3570	911	3745	931	3923	—	—	—	—		
6000 [2831]	—	—	—	621	1822	646	1961	671	2103	695	2248	719	2397	742	2548	765	2703	788	2860	810	3021	832	3185	854	3353	875	3523	896	3696	916	3873	936	4053	—	—	—	—		
6200 [2926]	—	—	—	607	1797	632	1935	657	2076	681	2220	705	2367	728	2517	751	2671	774	2827	796	2987	818	3150	840	3316	861	3485	881	3657	902	3833	921	4011	941	4193	—	—	—	
6400 [3020]	—	—	—	619	1919	644	2058	668	2201	692	2347	715	2496	738	2649	761	2804	783	2962	805	3124	826	3289	847	3457	868	3628	888	3802	908	3980	927	4160	—	—	—	—		
6600 [3114]	—	—	—	607	1912	632	2051	656	2192	679	2337	703	2485	726	2636	748	2790	770	2947	792	3108	813	3272	834	3438	855	3608	875	3781	895	3957	914	4137	933	4319	—	—	—	
6800 [3209]	—	—	—	620	2052	644	2193	668	2336	691	2483	714	2633	737	2786	759	2942	780	3101	802	3264	822	3429	843	3598	863	3770	883	3945	902	4123	921	4304	940	4489	—	—	—	
7000 [3303]	610	2064	634	2203	657	2345	681	2491	703	2640	726	2791	748	2946	769	3104	791	3266	811	3430	832	3598	852	3768	871	3942	891	4119	910	4299	928	4482	—	—	—	—			
7200 [3398]	624	2223	648	2364	671	2508	693	2656	716	2807	738	2960	759	3117	780	3277	801	3440	822	3607	841	3776	861	3949	880	4124	899	4303	917	4485	936	4670	—	—	—	—			
7400 [3492]	639	2392	662	2536	684	2682	707	2831	728	2984	750	3139	771	3298	792	3460	812	3625	832	3794	851	3965	871	4139	889	4317	908	4498	926	4682	—	—	—	—	—				
7600 [3586]	653	2572	676	2717	698	2866	720	3017	742	3171	763	3329	783	3480	803	3654	823	3821	843	3991	862	4164	881	4341	899	4520	917	4703	934	4889	—	—	—	—	—				
7800 [3681]	669	2762	691	2910	713	3060	734	3213	755	3369	775	3529	796	3692	815	3857	835	4026	854	4199	872	4374	891	4552	909	4734	926	4918	—	—	—	—	—	—	—				
8000 [3775]	684	2963	706	3112	727	3264	748	3419	769	3578	789	3739	808	3904	828	4072	847	4243	865	4417	883	4594	901	4774	919	4958	936	5144	—	—	—	—	—	—	—				
8200 [3869]	700	3174	721	3325	742	3479	762	3636	783	3796	802	3960	821	4127	840	4296	859	4469	877	4645	895	4824	912	5007	929	5192	—	—	—	—	—	—	—	—	—	—			
8400 [3964]	716	3395	737	3548	757	3704	777	3853	797	4026	816	4191	835	4359	853	4531	871	4706	889	4884	906	5065	923	5249	940	5437	—	—	—	—	—	—	—	—	—	—			

NOTE: L-Drive left of bold line, M-Drive right of bold line.

Drive Package	L, R						M, S					
Motor H.P. [W]	3.0 [2237.1]						5.0 [3728.5]					
Blower Sheave	CK100H						CK105H					
Motor Sheave	1VP-44						1VP-56					
Turns Open	1	2	3	4	5	6	1	2	3	4	5	6
RPM	763	731	699	666	633	601	939	909	879	845	814	781

- NOTES: 1. Factory sheave settings are shown in bold type.
 2. Do not set motor sheave below minimum turns open shown.
 3. Re-adjustment of sheave required to achieve rated airflow at AHRI minimum External Static Pressure.
 4. Drive data shown is for horizontal airflow with dry coil. Add component resistance (below) to duct resistance to determine total External Static Pressure.

[] Designates Metric Conversions

COMPONENT AIR RESISTANCE — 17.5 TON [61.5 kW]

CFM [L/s]	Resistance — Inches of Water [kPa]															
	5600 [2643]	5800 [2737]	6000 [2831]	6200 [2926]	6400 [3020]	6600 [3114]	6800 [3209]	7000 [3303]	7200 [3398]	7400 [3492]	7600 [3586]	7800 [3681]	8000 [3775]	8200 [3869]	8400 [3964]	
Wet Coil	0.06 [.01]	0.07 [.02]	0.08 [.02]	0.09 [.02]	0.10 [.02]	0.10 [.02]	0.11 [.03]	0.12 [.03]	0.13 [.03]	0.14 [.03]	0.14 [.03]	0.15 [.04]	0.16 [.04]	0.17 [.04]	0.18 [.04]	
Downflow	0.05 [.01]	0.05 [.01]	0.05 [.01]	0.06 [.01]	0.06 [.01]	0.07 [.01]	0.08 [.02]	0.08 [.02]	0.09 [.02]	0.10 [.02]	0.10 [.02]	0.11 [.03]	0.12 [.03]	0.13 [.03]	0.14 [.03]	
Downflow Economizer R.A. Damper Open	0.12 [.03]	0.13 [.03]	0.13 [.03]	0.14 [.03]	0.15 [.04]	0.16 [.04]	0.16 [.04]	0.17 [.04]	0.18 [.04]	0.19 [.05]	0.20 [.05]	0.21 [.05]	0.22 [.05]	0.23 [.06]	0.24 [.06]	
Horizontal Economizer R.A. Damper Open	0.02 [.00]	0.03 [.01]	0.03 [.01]	0.04 [.01]	0.04 [.01]	0.05 [.01]	0.05 [.01]	0.06 [.01]	0.06 [.01]	0.07 [.02]	0.07 [.02]	0.08 [.02]	0.09 [.02]	0.09 [.02]	0.10 [.02]	
Concentric Grill RXRN-AD80 or RXRN-AD81 & Transition RXMC-CJ07	0.35 [.09]	0.39 [.10]	0.43 [.11]	0.46 [.11]	0.50 [.11]	0.54 [.13]	0.57 [.14]	0.61 [.15]	0.64 [.16]	0.68 [.17]	0.72 [.18]	0.75 [.19]	0.79 [.20]	0.83 [.21]	0.86 [.21]	
Concentric Grill RXRN-AD86 & Transition RXMC-CK08	0.14 [.03]	0.17 [.04]	0.20 [.05]	0.23 [.06]	0.26 [.06]	0.29 [.07]	0.32 [.08]	0.35 [.09]	0.38 [.09]	0.41 [.10]	0.44 [.11]	0.47 [.12]	0.50 [.12]	0.53 [.13]	0.56 [.14]	
Pressure Drop MERV 8	0.084 [.02]	0.088 [.02]	0.092 [.02]	0.096 [.02]	0.1 [.02]	0.104 [.02]	0.108 [.03]	0.112 [.03]	0.116 [.03]	0.12 [.03]	0.124 [.03]	0.128 [.03]	0.132 [.03]	0.136 [.03]	0.14 [.03]	
Pressure Drop MERV 13	0.034 [.02]	0.04 [.02]	0.046 [.02]	0.052 [.02]	0.058 [.02]	0.065 [.02]	0.071 [.02]	0.077 [.02]	0.083 [.02]	0.089 [.02]	0.095 [.02]	0.102 [.02]	0.108 [.03]	0.114 [.03]	0.12 [.03]	

AIRFLOW CORRECTION FACTORS — 17.5 TON [61.5 kW]

ACTUAL—CFM [L/s]	5600 [2643]	5800 [2737]	6000 [2831]	6200 [2926]	6400 [3020]	6600 [3114]	6800 [3209]	7000 [3303]	7200 [3398]	7400 [3492]	7600 [3586]	7800 [3681]	8000 [3775]	8200 [3869]	8400 [3964]
TOTAL MBUH	0.96	0.97	0.97	0.98	0.98	0.99	0.99	1.00	1.00	1.01	1.01	1.02	1.03	1.03	1.04
SENSIBLE MBUH	0.86	0.88	0.90	0.92	0.94	0.96	0.98	1.00	1.02	1.04	1.06	1.08	1.10	1.12	1.14
POWER kW	0.99	0.99	0.99	0.99	1.00	1.00	1.00	1.00	1.01	1.01	1.01	1.01	1.02	1.02	1.02

NOTES: Multiply correction factor times gross performance data—resulting sensible capacity cannot exceed total capacity.

[] Designates Metric Conversions

COMPONENT AIRFLOW RESISTANCE—20 TON [70.3 kW] (C/H 240)

CFM [L/s]	6400	6600	6800	7000	7200	7400	7600	7800	8000	8200	8400	8600	8800	9000	9200	9400	9600
	[3020]	[3114]	[3209]	[3303]	[3398]	[3492]	[3586]	[3681]	[3775]	[3869]	[3964]	[4058]	[4153]	[4247]	[4341]	[4436]	[4530]
Resistance — Inches of Water [kPa]																	
Wet Coil	0.00 [.00]	0.00 [.00]	0.00 [.00]	0.01 [.00]	0.01 [.00]	0.02 [.00]	0.02 [.00]	0.03 [.01]	0.03 [.01]	0.04 [.01]	0.04 [.01]	0.05 [.01]	0.05 [.01]	0.06 [.01]	0.06 [.01]	0.07 [.02]	0.07 [.02]
Downflow	0.06 [.01]	0.06 [.01]	0.07 [.02]	0.08 [.02]	0.08 [.02]	0.09 [.02]	0.10 [.02]	0.11 [.03]	0.12 [.03]	0.13 [.03]	0.14 [.03]	0.15 [.04]	0.16 [.04]	0.18 [.04]	0.19 [.05]	0.20 [.05]	0.22 [.05]
Downflow Economizer R.A. Damper Open	0.15 [.04]	0.16 [.04]	0.16 [.04]	0.17 [.04]	0.18 [.04]	0.19 [.05]	0.20 [.05]	0.21 [.05]	0.22 [.05]	0.23 [.06]	0.24 [.06]	0.25 [.06]	0.26 [.06]	0.27 [.07]	0.28 [.07]	0.29 [.07]	0.30 [.07]
Horizontal Economizer R.A. Damper Open	0.04 [.01]	0.05 [.01]	0.05 [.01]	0.06 [.01]	0.06 [.01]	0.07 [.02]	0.07 [.02]	0.08 [.02]	0.09 [.02]	0.09 [.02]	0.10 [.02]	0.10 [.02]	0.11 [.03]	0.11 [.03]	0.12 [.03]	0.12 [.03]	0.13 [.03]
Concentric Grill RXRN-AD86 & Transition RXMC-CK08	0.26 [.06]	0.29 [.07]	0.32 [.08]	0.35 [.09]	0.38 [.09]	0.41 [.10]	0.44 [.11]	0.47 [.12]	0.50 [.12]	0.53 [.13]	0.56 [.14]	0.59 [.15]	0.62 [.15]	0.65 [.16]	0.69 [.17]	0.72 [.18]	0.75 [.19]
Pressure Drop MERV 8	0.1 [.02]	0.104 [.02]	0.108 [.03]	0.112 [.03]	0.116 [.03]	0.12 [.03]	0.124 [.03]	0.128 [.03]	0.132 [.03]	0.136 [.03]	0.14 [.03]	0.144 [.03]	0.148 [.04]	0.152 [.04]	0.156 [.04]	0.16 [.04]	0.164 [.04]
Pressure Drop MERV 13	0.058 [.01]	0.065 [.02]	0.071 [.02]	0.077 [.02]	0.083 [.02]	0.089 [.02]	0.095 [.02]	0.102 [.02]	0.108 [.03]	0.114 [.03]	0.12 [.03]	0.126 [.03]	0.132 [.03]	0.138 [.03]	0.145 [.04]	0.151 [.04]	0.157 [.04]

AIRFLOW CORRECTION FACTORS—20 TON [70.3 kW] (C/H 240)

ACTUAL—CFM [L/s]	6400 [3020]	6600 [3114]	6800 [3209]	7000 [3303]	7200 [3398]	7400 [3492]	7600 [3586]	7800 [3681]	8000 [3775]	8200 [3869]	8400 [3964]	8600 [4058]	8800 [4153]	9000 [4247]	9200 [4341]	9400 [4436]	9600 [4530]
TOTAL MBH	0.97	0.97	0.98	0.98	0.99	0.99	1.00	1.00	1.01	1.01	1.01	1.02	1.03	1.03	1.03	1.04	1.04
SENSIBLE MBH	0.88	0.90	0.92	0.94	0.96	0.97	0.99	1.01	1.03	1.05	1.07	1.09	1.10	1.12	1.14	1.16	1.18
POWER KW	0.98	0.99	0.99	0.99	0.99	1.00	1.00	1.00	1.00	1.01	1.01	1.01	1.01	1.01	1.02	1.02	1.02

NOTES: Multiply correction factor times gross performance data—resulting sensible capacity cannot exceed total capacity.

[] Designates Metric Conversions

AIRFLOW PERFORMANCE — 20 TON [70.3 kW] — 60 Hz — SIDEFLOW (C241)

Air Flow CFM [L/s]	Capacity 20 Ton [70.3 kW] Voltage 208/230, 460, 575 — 3 Phase 60 Hz																																							
	External Static Pressure—Inches of Water [kPa]																																							
	0.1 [0.02]	0.2 [0.05]	0.3 [0.07]	0.4 [0.10]	0.5 [0.12]	0.6 [0.15]	0.7 [0.17]	0.8 [0.20]	0.9 [0.22]	1.0 [0.25]	1.1 [0.27]	1.2 [0.30]	1.3 [0.32]	1.4 [0.35]	1.5 [0.37]	1.6 [0.40]	1.7 [0.42]	1.8 [0.45]	1.9 [0.47]	2.0 [0.50]																				
RPM	W	RPM	W	RPM	W	RPM	W	RPM	W	RPM	W	RPM	W	RPM	W	RPM	W	RPM	W	RPM	W																			
6400 [3020]	—	—	—	—	685	2151	707	2306	729	2461	750	2617	771	2774	792	2932	813	3090	833	3250	853	3409	872	3570	892	3731	911	3894	929	4056	948	4220	966	4384	984	4549				
6600 [3114]	—	—	—	—	698	2306	720	2462	741	2619	762	2777	783	2936	804	3095	824	3255	844	3415	863	3577	882	3739	901	3902	920	4065	938	4230	956	4395	974	4561	992	4727				
6800 [3209]	—	—	—	—	690	2313	712	2470	733	2628	754	2786	775	2946	795	3266	835	3428	854	3590	874	3753	892	3917	911	4081	929	4246	947	4412	965	4579	983	4746	1000	4914				
7000 [3303]	—	—	—	—	682	2327	704	2484	725	2643	746	2802	766	2962	787	3123	807	3285	827	3447	846	3610	865	3774	884	3938	903	4103	921	4269	939	4436	957	4603	974	4771	991	4940	1008	5110
7200 [3398]	—	—	—	—	696	2505	717	2665	738	2825	759	2985	779	3147	799	3309	819	3472	838	3636	857	3801	876	3966	895	4132	913	4299	931	4466	949	4634	966	4803	983	4973	1000	5143		
7400 [3492]	—	—	—	—	689	2533	710	2693	731	2854	752	3015	772	3177	792	3341	812	3504	831	3669	850	3834	869	4000	887	4167	906	4334	924	4503	941	4672	959	4841	976	5012	992	5183	1009	5355
7600 [3586]	682	2566	704	2727	724	2889	745	3051	765	3214	785	3378	805	3543	824	3708	843	3874	862	4041	880	4209	899	4377	917	4546	934	4716	951	4886	968	5057	985	5229	1002	5402	—	—	—	
7800 [3681]	697	2768	718	2931	739	3094	759	3258	779	3423	798	3588	818	3754	837	3921	856	4089	874	4257	892	4426	910	4596	928	4766	945	4937	962	5109	979	5282	995	5456	—	—	—			
8000 [3775]	712	2979	733	3143	753	3308	773	3473	793	3640	812	3806	831	3974	850	4142	869	4312	886	4481	904	4652	921	4823	939	4995	956	5168	972	5342	989	5516	1005	5691	—	—	—			
8200 [3869]	728	3199	748	3365	768	3531	787	3698	806	3865	825	4034	844	4203	862	4373	881	4543	898	4715	916	4887	933	5060	950	5233	967	5407	983	5583	999	5758	—	—	—	—	—			
8400 [3964]	743	3428	763	3595	782	3762	802	3931	820	4100	839	4270	857	4441	875	4612	893	4784	911	4957	928	5131	945	5305	961	5480	978	5656	994	5832	1009	6010	—	—	—	—	—			
8600 [4058]	758	3665	778	3834	797	4003	816	4173	835	4343	853	4515	871	4687	889	4860	906	5034	923	5208	940	5383	956	5559	973	5735	989	5913	1004	6091	—	—	—	—	—	—	—			
8800 [4153]	774	3911	793	4081	812	4252	830	4423	849	4596	867	4769	884	4942	902	5117	919	5292	936	5468	952	5644	968	5822	984	6000	1000	6179	—	—	—	—	—	—	—	—	—			
9000 [4247]	790	4166	808	4338	827	4510	845	4683	863	4857	881	5031	898	5206	915	5382	932	5559	948	5736	964	5915	980	6093	996	6273	—	—	—	—	—	—	—	—	—	—	—	—	—	
9200 [4341]	805	4430	824	4603	842	4771	860	4951	877	5127	895	5303	912	5479	929	5657	945	5835	961	6014	977	6194	992	6374	1008	6555	—	—	—	—	—	—	—	—	—	—	—	—	—	
9400 [4436]	821	4703	839	4877	857	5052	875	5229	892	5405	909	5583	926	576	942	5940	958	6120	974	6300	989	6481	1005	6663	—	—	—	—	—	—	—	—	—	—	—	—	—	—	—	—
9600 [4530]	837	4984	855	5160	872	5337	890	5514	907	5693	923	5872	940	6052	956	6232	971	6413	987	6595	1002	6778	—	—	—	—	—	—	—	—	—	—	—	—	—	—	—	—	—	—

NOTE: L-Drive left of bold line, M-Drive right of bold line, N-Drive right of double line.

Drive Package	L	M						N (field installed only)																
Motor H.P. [W]	5.0 [3728.5]	7.5 [5592.7]						7.5 [5592.7]																
Blower Sheave	BK120H	BK130H						BK120H																
Motor Sheave	1VP-56	1VP-71						1VP-71																
Turns Open	1	2	3	4	5	6	1	2	3	4	5	6	1	2	3	4	5	6	1	2	3	4	5	6
RPM	822	798	771	742	712	684	932	905	878	851	824	797	1007	978	949	921	892	863	834	805	776	747	718	689

NOTES: 1. Factory sheave settings are shown in bold type.
2. Do not set motor sheave below minimum turns open shown.
3. Re-adjustment of sheave required to achieve rated airflow at AHRI minimum External Static Pressure.
4. Drive data shown is for horizontal airflow with dry coil. Add component resistance (below) to duct resistance to determine total External Static Pressure.

[] Designates Metric Conversions

COMPONENT AIRFLOW RESISTANCE—20 TON [70.3 kW] (C241)

Airflow CFM [L/s]	Airflow Correction Factors*				Component Airflow Resistance								
	Total MBH	Sensible MBH	Power kW	Wet Coil	Downflow	Downflow Economizer RA Damper Open	Horizontal Economizer RA Damper Open	Concentric Grill RXRN-AD80 or RXRN-AD81 & Transition RXMC-CJ07	Concentric Grill RXRN-AD86 & Transition RXMC-CK08	Concentric Grill RXRN-AD88 & Transition RXMC-CL09	Pressure Drop MERV 8	Pressure Drop MERV 13	
													Resistance — Inches of Water [kPa]
6400 [3020]	0.97	0.88	0.98	0.01 [0.00]	0.06 [01]	0.15 [04]	0.04 [01]	0.50 [12]	—	—	—	0.100 [02]	0.058 [01]
6600 [3114]	0.97	0.90	0.99	0.02 [00]	0.06 [01]	0.16 [04]	0.05 [01]	0.54 [13]	—	—	—	0.104 [02]	0.065 [02]
6800 [3209]	0.98	0.92	0.99	0.03 [01]	0.07 [02]	0.16 [04]	0.05 [01]	—	—	—	—	0.108 [03]	0.071 [02]
7000 [3303]	0.98	0.94	0.99	0.03 [01]	0.08 [02]	0.17 [04]	0.06 [01]	—	—	—	—	0.112 [03]	0.077 [02]
7200 [3398]	0.99	0.96	0.99	0.04 [01]	0.08 [02]	0.18 [04]	0.06 [01]	—	0.38 [09]	—	—	0.116 [03]	0.083 [02]
7400 [3492]	0.99	0.97	1.00	0.05 [01]	0.09 [02]	0.19 [05]	0.07 [02]	—	0.41 [10]	—	—	0.120 [03]	0.089 [02]
7600 [3586]	1.00	0.99	1.00	0.06 [01]	0.10 [02]	0.20 [05]	0.07 [02]	—	0.44 [11]	—	—	0.124 [03]	0.095 [02]
7800 [3681]	1.00	1.01	1.00	0.06 [01]	0.11 [03]	0.21 [05]	0.08 [02]	—	0.47 [12]	—	—	0.128 [03]	0.102 [02]
8000 [3775]	1.01	1.03	1.00	0.07 [02]	0.12 [03]	0.22 [05]	0.09 [02]	—	0.50 [12]	—	—	0.132 [03]	0.108 [03]
8200 [3869]	1.01	1.05	1.01	0.08 [02]	0.13 [03]	0.23 [06]	0.09 [02]	—	0.53 [13]	—	—	0.136 [03]	0.114 [03]
8400 [3964]	1.02	1.07	1.01	0.09 [02]	0.14 [03]	0.24 [06]	0.10 [02]	—	0.56 [14]	—	—	0.140 [03]	0.120 [03]
8600 [4058]	1.02	1.09	1.01	0.09 [02]	0.15 [04]	0.25 [06]	0.10 [02]	—	0.59 [15]	—	—	0.144 [03]	0.126 [03]
8800 [4153]	1.03	1.10	1.01	0.10 [02]	0.16 [04]	0.26 [06]	0.11 [03]	—	0.62 [15]	—	—	0.148 [04]	0.132 [03]
9000 [4247]	1.03	1.12	1.01	0.11 [03]	0.18 [04]	0.27 [07]	0.11 [03]	—	—	—	—	0.152 [04]	0.138 [03]
9200 [4341]	1.03	1.14	1.02	0.12 [03]	0.19 [05]	0.28 [07]	0.12 [03]	—	—	—	—	0.156 [04]	0.145 [04]
9400 [4436]	1.04	1.16	1.02	0.12 [03]	0.20 [05]	0.29 [07]	0.12 [03]	—	—	—	—	0.160 [04]	0.151 [04]
9600 [4530]	1.04	1.18	1.02	0.13 [03]	0.22 [05]	0.30 [07]	0.13 [03]	—	—	—	—	0.164 [04]	0.160 [04]

* Multiply correction factor times gross performance data—resulting sensible capacity cannot exceed total capacity.

[] Designates Metric Conversions

AIRFLOW PERFORMANCE — 25 TON [87.9 kW] — SIDEFLOW

Air Flow CFM [L/s]	Capacity 25 Ton [87.9 kW] Voltage 208/230, 460, 575 — 3 Phase																																					
	External Static Pressure—Inches of Water [kPa]																																					
	0.1 [0.02]	0.2 [0.05]	0.3 [0.07]	0.4 [0.10]	0.5 [0.12]	0.6 [0.15]	0.7 [0.17]	0.8 [0.20]	0.9 [0.22]	1.0 [0.25]	1.1 [0.27]	1.2 [0.30]	1.3 [0.32]	1.4 [0.35]	1.5 [0.37]	1.6 [0.40]	1.7 [0.42]	1.8 [0.45]	1.9 [0.47]	2.0 [0.50]																		
RPM	W	RPM	W	RPM	W	RPM	W	RPM	W	RPM	W	RPM	W	RPM	W	RPM	W	RPM	W	RPM	W	RPM	W	RPM	W	RPM	W	RPM	W									
8000 [3775]	—	—	—	—	—	—	—	—	—	—	—	—	—	—	—	—	—	—	—	—	—	—	—	—	—	—	—	—	—	—								
8200 [3869]	—	—	—	—	—	—	—	—	—	—	—	—	—	—	—	—	—	—	—	—	—	—	—	—	—	—	—	—	—	—								
8400 [3964]	—	—	—	—	—	—	—	—	—	—	—	—	—	—	—	—	—	—	—	—	—	—	—	—	—	—	—	—	—	—								
8600 [4058]	—	—	—	—	—	—	—	—	—	—	—	—	—	—	—	—	—	—	—	—	—	—	—	—	—	—	—	—	—	—								
8800 [4153]	—	—	—	—	—	—	—	—	—	—	—	—	—	—	—	—	—	—	—	—	—	—	—	—	—	—	—	—	—	—								
9000 [4247]	—	—	—	—	—	—	—	—	—	—	—	—	—	—	—	—	—	—	—	—	—	—	—	—	—	—	—	—	—	—								
9200 [4341]	—	—	—	—	—	—	—	—	—	—	—	—	—	—	—	—	—	—	—	—	—	—	—	—	—	—	—	—	—	—								
9400 [4436]	—	—	—	—	—	—	—	—	—	—	—	—	—	—	—	—	—	—	—	—	—	—	—	—	—	—	—	—	—	—								
9600 [4530]	—	—	—	—	—	—	—	—	—	—	—	—	—	—	—	—	—	—	—	—	—	—	—	—	—	—	—	—	—	—								
9800 [4624]	—	—	—	—	—	—	—	—	—	—	—	—	—	—	—	—	—	—	—	—	—	—	—	—	—	—	—	—	—	—								
10000 [4719]	793	4714	813	4910	831	5110	849	5315	867	5523	884	5735	901	5951	917	6171	945	6446	960	6647	975	6849	990	7052	1005	7256	1019	7461	1034	7667	1050	7873	1065	8081	—	—	—	—
10200 [4813]	808	4978	827	5181	845	5389	863	5600	880	5816	897	6035	913	6259	941	6542	956	6748	971	6954	986	7162	1001	7370	1016	7579	1031	7789	1046	8000	1061	8212	—	—	—	—		
10400 [4908]	822	5254	840	5465	858	5680	876	5899	893	6122	909	6349	926	6580	953	6852	967	7063	982	7275	997	7488	1012	7701	1027	7916	1042	8131	1057	8348	1072	8565	—	—	—	—		
10600 [5002]	836	5543	854	5761	872	5984	889	6210	906	6441	922	6675	949	6961	964	7176	979	7393	993	7610	1008	7828	1023	8047	1038	8267	1053	8488	1068	8710	—	—	—	—	—			
10800 [5096]	850	5845	868	6071	885	6301	902	6534	918	6772	946	7074	961	7294	975	7514	990	7736	1005	7959	1020	8182	1035	8407	1050	8632	1065	8858	—	—	—	—	—	—	—			
11000 [5191]	864	6160	882	6399	899	6630	915	6871	943	7191	958	7415	972	7640	987	7867	1002	8094	1017	8321	1032	8550	1046	8780	1061	9011	—	—	—	—	—	—	—	—	—			
11200 [5285]	878	6487	895	6728	912	6972	940	7313	955	7541	969	7771	984	8001	999	8233	1014	8465	1029	8698	1043	8933	1058	9168	—	—	—	—	—	—	—	—	—	—	—	—		
11400 [5379]	892	6827	909	7075	925	7328	952	7671	967	7905	981	8140	996	8376	1011	8613	1026	8851	1041	9089	1055	9329	1070	9570	—	—	—	—	—	—	—	—	—	—	—	—		
11600 [5474]	906	7180	922	7436	950	7806	964	8044	979	8283	994	8624	1008	8765	1023	9007	1038	9250	1053	9494	1068	9739	—	—	—	—	—	—	—	—	—	—	—	—	—	—		
11800 [5568]	920	7546	948	7944	962	8187	977	8431	991	8676	1006	8921	1021	9168	1035	9416	1050	9664	1065	9913	—	—	—	—	—	—	—	—	—	—	—	—	—	—	—	—		
12000 [5663]	946	8087	960	8334	975	8583	989	8832	1004	9082	1019	9333	1033	9585	1048	9838	1063	10092	—	—	—	—	—	—	—	—	—	—	—	—	—	—	—	—	—	—		

NOTE: L-Drive left of bold line, M-Drive right of bold line.

Drive Package	L, R	M, S
Motor H.P. [W]	7.5 [5592.7]	10 [7457.0]
Blower Sheave	CK130H	CK120H
Motor Sheave	1VP-71	1VP-75
Turns Open	1 2 3 4 5 6	1 2 3 4 5 6
RPM	919 894 869 844 817 790	1067 1039 1012 982 953 925

- NOTES: 1. Factory sheave settings are shown in bold type.
 2. Do not set motor sheave below minimum turns open shown.
 3. Re-adjustment of sheave required to achieve rated airflow at AHRI minimum External Static Pressure.
 4. Drive data shown is for horizontal airflow with dry coil. Add component resistance (below) to duct resistance to determine total External Static Pressure.

[] Designates Metric Conversions

COMPONENT AIR RESISTANCE – 25 TON [87.9 kW]

CFM [L/s]	8000	8400	8800	9200	9600	10000	10400	10800	11200	11600	12000
	[3775]	[3964]	[4153]	[4341]	[4530]	[4719]	[4908]	[5096]	[5285]	[5474]	[5663]
Resistance — Inches of Water [kPa]											
Wet Coil	0.07 [.02]	0.09 [.02]	0.10 [.02]	0.12 [.03]	0.13 [.03]	0.15 [.04]	0.16 [.04]	0.18 [.04]	0.19 [.05]	0.21 [.05]	0.22 [.05]
Downflow	0.12 [.03]	0.14 [.03]	0.16 [.04]	0.19 [.05]	0.22 [.05]	0.25 [.06]	0.29 [.07]	0.33 [.08]	0.37 [.09]	0.42 [.10]	0.46 [.11]
Downflow Economizer R.A. Damper Open	0.22 [.05]	0.24 [.06]	0.26 [.06]	0.28 [.07]	0.30 [.07]	0.32 [.08]	0.34 [.08]	0.37 [.09]	0.39 [.10]	0.41 [.10]	0.44 [.11]
Horizontal Economizer R.A. Damper Open	0.09 [.02]	0.10 [.02]	0.11 [.03]	0.12 [.03]	0.13 [.03]	0.14 [.03]	0.15 [.04]	0.16 [.04]	0.17 [.04]	0.18 [.04]	0.19 [.05]
Concentric Grill RXRN-AD88 & Transition RXMC-CL09	0.17 [.04]	0.23 [.06]	0.30 [.07]	0.36 [.09]	0.43 [.11]	0.50 [.12]	0.56 [.14]	0.63 [.16]	0.69 [.17]	0.76 [.19]	0.82 [.20]
Pressure Drop MERV 8	0.132 [.03]	0.14 [.03]	0.148 [.04]	0.156 [.04]	0.164 [.04]	0.172 [.04]	0.18 [.04]	0.188 [.05]	0.196 [.05]	0.204 [.05]	0.212 [.05]
Pressure Drop MERV 13	0.108 [.03]	0.12 [.03]	0.132 [.03]	0.145 [.04]	0.157 [.04]	0.169 [.04]	0.182 [.04]	0.194 [.05]	0.206 [.05]	0.219 [.05]	0.231 [.06]

AIRFLOW CORRECTION FACTORS – 25 TON [87.9 kW]

ACTUAL—CFM [L/s]	8000 [3775]	8400 [3964]	8800 [4153]	9200 [4341]	9600 [4530]	10000 [4719]	10400 [4908]	10800 [5096]	11200 [5285]	11600 [5474]	12000 [5663]
TOTAL MBTUH	0.97	0.98	0.99	0.99	1.00	1.01	1.02	1.03	1.03	1.04	1.05
SENSIBLE MBTUH	0.89	0.92	0.95	0.98	1.01	1.04	1.08	1.11	1.14	1.17	1.20
POWER kW	0.99	0.99	1.00	1.00	1.00	1.01	1.01	1.01	1.02	1.02	1.02

NOTES: Multiply correction factor times gross performance data—resulting sensible capacity cannot exceed total capacity.

[] Designates Metric Conversions

ELECTRICAL DATA – RLNL- SERIES

		H180CR	H180CS	H180DR	H180DS	C180YL	C180YM	H210CR	H210CS	H210DR
Unit Information	Unit Operating Voltage Range	187-253	187-253	414-506	414-506	518-632	518-632	187-253	187-253	414-506
	Volts	208/230	208/230	460	460	575	575	208/230	208/230	460
	Minimum Circuit Ampacity	78/78	81/81	38	40	28	30	88/88	91/91	44
	Minimum Overcurrent Protection Device Size	90/90	90/90	45	45	30	35	100/100	100/100	50
	Maximum Overcurrent Protection Device Size	100/100	100/100	45	50	35	35	110/110	110/110	50
Compressor Motor	No.	2	2	2	2	2	2	2	2	2
	Volts	200/230	200/230	460	460	575	575	200/230	200/230	460
	Phase	3	3	3	3	3	3	3	3	3
	RPM	3450	3450	3450	3450	3450	3450	3450	3450	3450
	HP, Compressor 1	7	7	7	7	7	7	7 1/2	7 1/2	7 1/2
	Amps (RLA), Comp. 1	25/25	25/25	12.2	12.2	9	9	29.5/29.5	29.5/29.5	14.7
	Amps (LRA), Comp. 1	164/164	164/164	100	100	78	78	195/195	195/195	95
	HP, Compressor 2	7	7	7	7	7	7	7 1/2	7 1/2	7 1/2
	Amps (RLA), Comp. 2	25/25	25/25	12.2	12.2	9	9	29.5/29.5	29.5/29.5	14.7
Amps (LRA), Comp. 2	164/164	164/164	100	100	78	78	195/195	195/195	95	
Condenser Motor	No.	4	4	4	4	4	4	4	4	4
	Volts	208/230	208/230	460	460	575	575	208/230	208/230	460
	Phase	1	1	1	1	1	1	1	1	1
	HP	1/3	1/3	1/3	1/3	1/3	1/3	1/3	1/3	1/3
	Amps (FLA, each)	2.4/2.4	2.4/2.4	1.4	1.4	1	1	2.4/2.4	2.4/2.4	1.4
	Amps (LRA, each)	4.7/4.7	4.7/4.7	2.4	2.4	1.8	1.8	4.7/4.7	4.7/4.7	2.4
Evaporator Fan	No.	1	1	1	1	1	1	1	1	1
	Volts	208/230	208/230	460	460	575	575	208/230	208/230	460
	Phase	3	3	3	3	3	3	3	3	3
	HP	3	5	3	5	3	5	3	5	3
	Amps (FLA, each)	11.5/11.5	14.9/14.9	4.6	6.6	3.5	5.3	11.5/11.5	14.9/14.9	4.6
	Amps (LRA, each)	74.5/74.5	82.6/82.6	38.1	46.3	20	39.4	74.5/74.5	82.6/82.6	38.1

ELECTRICAL DATA – RLNL- SERIES										
		H210DS	C210YL	C210YM	H240CR	H240CS	H240CT	H240DR	H240DS	H240DT
Unit Information	Unit Operating Voltage Range	414-506	518-632	518-632	187-253	187-253	187-253	414-506	414-506	414-506
	Volts	460	575	575	208/230	208/230	208/230	460	460	460
	Minimum Circuit Ampacity	46	35	37	101/101	109/109	109/109	52	56	56
	Minimum Overcurrent Protection Device Size	50	40	40	110/110	125/125	125/125	60	60	60
	Maximum Overcurrent Protection Device Size	50	45	45	125/125	125/125	125/125	60	70	70
Compressor Motor	No.	2	2	2	2	2	2	2	2	2
	Volts	460	575	575	200/230	200/230	200/230	460	460	460
	Phase	3	3	3	3	3	3	3	3	3
	RPM	3450	3450	3450	3450	3450	3450	3450	3450	3450
	HP, Compressor 1	7 1/2	7 1/2	7 1/2	10	10	10	10	10	10
	Amps (RLA), Comp. 1	14.7	12.2	12.2	33.3/33.3	33.3/33.3	33.3/33.3	17.9	17.9	17.9
	Amps (LRA), Comp. 1	95	80	80	239/239	239/239	239/239	125	125	125
	HP, Compressor 2	7 1/2	7 1/2	7 1/2	7 1/2	7 1/2	7 1/2	7 1/2	7 1/2	7 1/2
	Amps (RLA), Comp. 2	14.7	12.2	12.2	29.5/29.5	29.5/29.5	29.5/29.5	14.7	14.7	14.7
Amps (LRA), Comp. 2	95	80	80	195/195	195/195	195/195	95	95	95	
Condenser Motor	No.	4	4	4	6	6	6	6	6	6
	Volts	460	575	575	208/230	208/230	208/230	460	460	460
	Phase	1	1	1	1	1	1	1	1	1
	HP	1/3	1/3	1/3	1/3	1/3	1/3	1/3	1/3	1/3
	Amps (FLA, each)	1.4	1	1	2.4/2.4	2.4/2.4	2.4/2.4	1.4	1.4	1.4
	Amps (LRA, each)	2.4	1.8	1.8	4.7/4.7	4.7/4.7	4.7/4.7	2.4	2.4	2.4
Evaporator Fan	No.	1	1	1	1	1	1	1	1	1
	Volts	460	575	575	208/230	208/230	208/230	460	460	460
	Phase	3	3	3	3	3	3	3	3	3
	HP	5	3	5	5	7 1/2	7 1/2	5	7 1/2	7 1/2
	Amps (FLA, each)	6.6	3.5	5.3	14.7/14.7	23.1/23.1	23.1/23.1	6.6	9.6	9.6
	Amps (LRA, each)	46.3	20	39.4	82.6/82.6	136/136	136/136	46.3	67	67

ELECTRICAL DATA – RLNL- SERIES

		H300CR	H300CS	H300DR	H300DS
Unit Information	Unit Operating Voltage Range	187-253	187-253	414-506	414-506
	Volts	208/230	208/230	460	460
	Minimum Circuit Ampacity	147/147	149/149	60	63
	Minimum Overcurrent Protection Device Size	175/175	175/175	70	70
	Maximum Overcurrent Protection Device Size	175/175	175/175	70	80
Compressor Motor	No.	2	2	2	2
	Volts	200/240	200/240	460	460
	Phase	3	3	3	3
	RPM	3450	3450	3450	3450
	HP, Compressor 1	11 1/2	11 1/2	11 1/2	11 1/2
	Amps (RLA), Comp. 1	48.1/48.1	48.1/48.1	18.6	18.6
	Amps (LRA), Comp. 1	245/245	245/245	125	125
	HP, Compressor 2	11 1/2	11 1/2	11 1/2	11 1/2
	Amps (RLA), Comp. 2	48.1/48.1	48.1/48.1	18.6	18.6
Amps (LRA), Comp. 2	245/245	245/245	125	125	
Condenser Motor	No.	6	6	6	6
	Volts	208/230	208/230	460	460
	Phase	1	1	1	1
	HP	1/3	1/3	1/3	1/3
	Amps (FLA, each)	2.4/2.4	2/2	1.4	1.4
	Amps (LRA, each)	4.7/4.7	3.9/3.9	2.4	2.4
Evaporator Fan	No.	1	1	1	1
	Volts	208/230	208/230	460	460
	Phase	3	3	3	3
	HP	7 1/2	10	7 1/2	10
	Amps (FLA, each)	24.2/24.2	28.5/28.5	9.6	12.5
	Amps (LRA, each)	136/136	178/178	67	74.6

208/240 VOLT, THREE PHASE, 60 HZ, AUXILIARY ELECTRIC HEATER KITS CHARACTERISTICS AND APPLICATION														
Separate Power Supply for Both Unit and Heater Kit														
Single Power Supply for Both Unit and Heater Kit														
Model No. RLNL-	Heater Kit				Air Conditioner				Heater Kit				Air Conditioner	
	RXJJ-Heater Kit Nominal kW	No. of Sequence Steps	Rated Heater kW @ 208/240V	Heater kBTU/Hr @ 208/240V	Heater Amps @ 208/240V	Unit Min. Ckt. Ampacity @ 208/240V	Over Current Protective Device Size Min./Max. 208V	Over Current Protective Device Size Min./Max. 240V	Min. Ckt. Ampacity 208/240V	Max. Fuse Size 208/240V	Min. Circuit Ampacity 208/240V	Over Current Protective Device Size Min./Max. 208V	Over Current Protective Device Size Min./Max. 240V	
H180CR	No Heat	—	—	—	—	78/78	90/100	90/100	—	—	78/78	90/100	90/100	
	CE20C	1	14.4/19.2	49.13/65.5	40/46.2	78/78	90/100	90/100	50/58	50/60	—	—	—	
	CE40C	2	28.8/38.3	98.25/130.66	79.9/92.2	115/130	125/125	150/150	100/116	100/125	—	—	—	
	CE60C	2	43.2/57.5	147.38/196.16	119.9/138.3	165/188	175/175	200/200	150/173	150/175	—	—	—	
	CE75C	2	54/71.9	184.22/245.29	149.8/172.8	202/231	225/225	250/250	188/217	200/225	—	—	—	
H210CR	No Heat	—	—	—	—	88/88	100/110	100/110	—	—	88/88	100/110	100/110	
	CE20C	1	14.4/19.2	49.13/65.5	40/46.2	88/88	100/110	100/110	50/58	50/60	—	—	—	
	CE40C	2	28.8/38.3	98.25/130.66	79.9/92.2	115/130	125/125	150/150	100/116	100/125	—	—	—	
	CE60C	2	43.2/57.5	147.38/196.16	119.9/138.3	165/188	175/175	200/200	150/173	150/175	—	—	—	
	CE75C	2	54/71.9	184.22/245.29	149.8/172.8	202/231	225/225	250/250	188/217	200/225	—	—	—	
H240CR	No Heat	—	—	—	—	101/101	110/125	110/125	—	—	101/101	110/125	110/125	
	CE20C	1	14.4/19.2	49.13/65.5	40/46.2	101/101	110/125	110/125	50/58	50/60	—	—	—	
	CE40C	2	28.8/38.3	98.25/130.66	79.9/92.2	119/134	125/125	150/150	100/116	100/125	—	—	—	
	CE60C	2	43.2/57.5	147.38/196.16	119.9/138.3	169/192	175/175	200/200	150/173	150/175	—	—	—	
	CE75C	2	54/71.9	184.22/245.29	149.8/172.8	206/235	225/225	250/250	188/217	200/225	—	—	—	
H300CR	No Heat	—	—	—	—	147/147	175/175	175/175	—	—	147/147	175/175	175/175	
	CE20C	1	14.4/19.2	49.13/65.5	40/46.2	147/147	175/175	175/175	50/58	50/60	—	—	—	
	CE40C	2	28.8/38.3	98.25/130.66	79.9/92.2	147/147	175/175	175/175	100/116	100/125	—	—	—	
	CE60C	2	43.2/57.5	147.38/196.16	119.9/138.3	181/204	200/200	225/225	150/173	150/175	—	—	—	
	CE75C	2	54/71.9	184.22/245.29	149.8/172.8	218/247	225/225	250/250	188/217	200/225	—	—	—	
H180CS	No Heat	—	—	—	—	81/81	90/100	90/100	—	—	81/81	90/100	90/100	
	CE20C	1	14.4/19.2	49.13/65.5	40/46.2	81/81	90/100	90/100	50/58	50/60	—	—	—	
	CE40C	2	28.8/38.3	98.25/130.66	79.9/92.2	119/134	125/125	150/150	100/116	100/125	—	—	—	
	CE60C	2	43.2/57.5	147.38/196.16	119.9/138.3	169/192	175/175	200/200	150/173	150/175	—	—	—	
	CE75C	2	54/71.9	184.22/245.29	149.8/172.8	206/235	225/225	250/250	188/217	200/225	—	—	—	
H210CS	No Heat	—	—	—	—	91/91	100/110	100/110	—	—	91/91	100/110	100/110	
	CE20C	1	14.4/19.2	49.13/65.5	40/46.2	91/91	100/110	100/110	50/58	50/60	—	—	—	
	CE40C	2	28.8/38.3	98.25/130.66	79.9/92.2	119/134	125/125	150/150	100/116	100/125	—	—	—	
	CE60C	2	43.2/57.5	147.38/196.16	119.9/138.3	169/192	175/175	200/200	150/173	150/175	—	—	—	
	CE75C	2	54/71.9	184.22/245.29	149.8/172.8	206/235	225/225	250/250	188/217	200/225	—	—	—	
H240CS	No Heat	—	—	—	—	109/109	125/125	125/125	—	—	109/109	125/125	125/125	
	CE20C	1	14.4/19.2	49.13/65.5	40/46.2	109/109	125/125	125/125	50/58	50/60	—	—	—	
	CE40C	2	28.8/38.3	98.25/130.66	79.9/92.2	129/145	150/150	150/150	100/116	100/125	—	—	—	
	CE60C	2	43.2/57.5	147.38/196.16	119.9/138.3	179/202	200/200	225/225	150/173	150/175	—	—	—	
	CE75C	2	54/71.9	184.22/245.29	149.8/172.8	217/245	225/225	250/250	188/217	200/225	—	—	—	
H300CS	No Heat	—	—	—	—	149/149	175/175	175/175	—	—	149/149	175/175	175/175	
	CE20C	1	14.4/19.2	49.13/65.5	40/46.2	149/149	175/175	175/175	50/58	50/60	—	—	—	
	CE40C	2	28.8/38.3	98.25/130.66	79.9/92.2	149/151	175/175	175/175	100/116	100/125	—	—	—	
	CE60C	2	43.2/57.5	147.38/196.16	119.9/138.3	186/209	200/200	225/225	150/173	150/175	—	—	—	
	CE75C	2	54/71.9	184.22/245.29	149.8/172.8	223/252	225/225	300/300	188/217	200/225	—	—	—	
H240CT	No Heat	—	—	—	—	109/109	125/125	125/125	—	—	109/109	125/125	125/125	
	CE20C	1	14.4/19.2	49.13/65.5	40/46.2	109/109	125/125	125/125	50/58	50/60	—	—	—	
	CE40C	2	28.8/38.3	98.25/130.66	79.9/92.2	129/145	150/150	150/150	100/116	100/125	—	—	—	
	CE60C	2	43.2/57.5	147.38/196.16	119.9/138.3	179/202	200/200	225/225	150/173	150/175	—	—	—	
	CE75C	2	54/71.9	184.22/245.29	149.8/172.8	217/245	225/225	250/250	188/217	200/225	—	—	—	

* = For Canadian use only. Uses "p" fuses for inductive circuit.

480 VOLT, THREE PHASE, 60 HZ, AUXILIARY ELECTRIC HEATER KITS CHARACTERISTICS AND APPLICATION													
Separate Power Supply for Both Unit and Heater Kit													
Model No. RLNL-	Single Power Supply for Both Unit and Heater Kit				Heater Kit				Air Conditioner				Air Conditioner
	RX/JJ- Heater Kit Nominal kW	No. of Sequence Steps	Rated Heater kW @ 480V	Heater kBTU/Hr @ 480V	Heater Amps @ 480V	Unit Min. Ckt. Ampacity @ 480V	Over Current Protective Device Size Min./Max. 480V		Min. Ckt. Ampacity 480V	Max. Fuse Size 480V	Min. Circuit Ampacity 480V	Over Current Protective Device Size Min./Max. 480V	
H180DR	No Heat	—	—	—	—	38	45/45	—	—	38	45/45	—	—
	CE20D	1	19.2	65.5	23.1	38	45/45	—	29	—	—	—	—
	CE40D	2	38.4	131	46.2	64	70/70	—	58	—	—	—	—
	CE60D	2	57.6	196.5	69.3	93	100/100	—	87	—	—	—	—
H210DR	CE75D	2	72	245.63	86.6	114	125/125	—	109	—	—	—	—
	No Heat	—	—	—	—	44	50/50	—	—	44	50/50	—	—
	CE20D	1	19.2	65.5	23.1	44	50/50	—	29	—	—	—	—
	CE40D	2	38.4	131	46.2	64	70/70	—	58	—	—	—	—
H240DR	CE60D	2	57.6	196.5	69.3	93	100/100	—	87	—	—	—	—
	CE75D	2	72	245.63	86.6	114	125/125	—	109	—	—	—	—
	No Heat	—	—	—	—	52	60/60	—	—	52	60/60	—	—
	CE20D	1	19.2	65.5	23.1	52	60/60	—	29	—	—	—	—
H300DR	CE40D	2	38.4	131	46.2	67	70/70	—	58	—	—	—	—
	CE60D	2	57.6	196.5	69.3	95	100/100	—	87	—	—	—	—
	CE75D	2	72	245.63	86.6	117	125/125	—	109	—	—	—	—
	No Heat	—	—	—	—	60	70/70	—	—	60	70/70	—	—
H180DS	CE20D	1	19.2	65.5	23.1	40	45/50	—	—	40	45/50	—	—
	CE40D	2	38.4	131	46.2	67	70/70	—	58	—	—	—	—
	CE60D	2	57.6	196.5	69.3	95	100/100	—	87	—	—	—	—
	CE75D	2	72	245.63	86.6	117	125/125	—	109	—	—	—	—
H210DS	No Heat	—	—	—	—	46	50/50	—	—	46	50/50	—	—
	CE20D	1	19.2	65.5	23.1	46	50/50	—	29	—	—	—	—
	CE40D	2	38.4	131	46.2	67	70/70	—	58	—	—	—	—
	CE60D	2	57.6	196.5	69.3	95	100/100	—	87	—	—	—	—
H240DS	CE75D	2	72	245.63	86.6	117	125/125	—	109	—	—	—	—
	No Heat	—	—	—	—	56	60/70	—	—	56	60/70	—	—
	CE20D	1	19.2	65.5	23.1	56	60/70	—	29	—	—	—	—
	CE40D	2	38.4	131	46.2	70	70/70	—	58	—	—	—	—
H300DS	CE60D	2	57.6	196.5	69.3	99	100/100	—	87	—	—	—	—
	CE75D	2	72	245.63	86.6	121	125/125	—	109	—	—	—	—
	No Heat	—	—	—	—	63	70/80	—	—	63	70/80	—	—
	CE20D	1	19.2	65.5	23.1	63	70/80	—	29	—	—	—	—
H240DT	CE40D	2	38.4	131	46.2	70	70/70	—	58	—	—	—	—
	CE60D	2	57.6	196.5	69.3	103	110/110	—	87	—	—	—	—
	CE75D	2	72	245.63	86.6	124	125/125	—	109	—	—	—	—
	No Heat	—	—	—	—	56	60/70	—	—	56	60/70	—	—

*= For Canadian use only. Uses "P" fuses for inductive circuit.

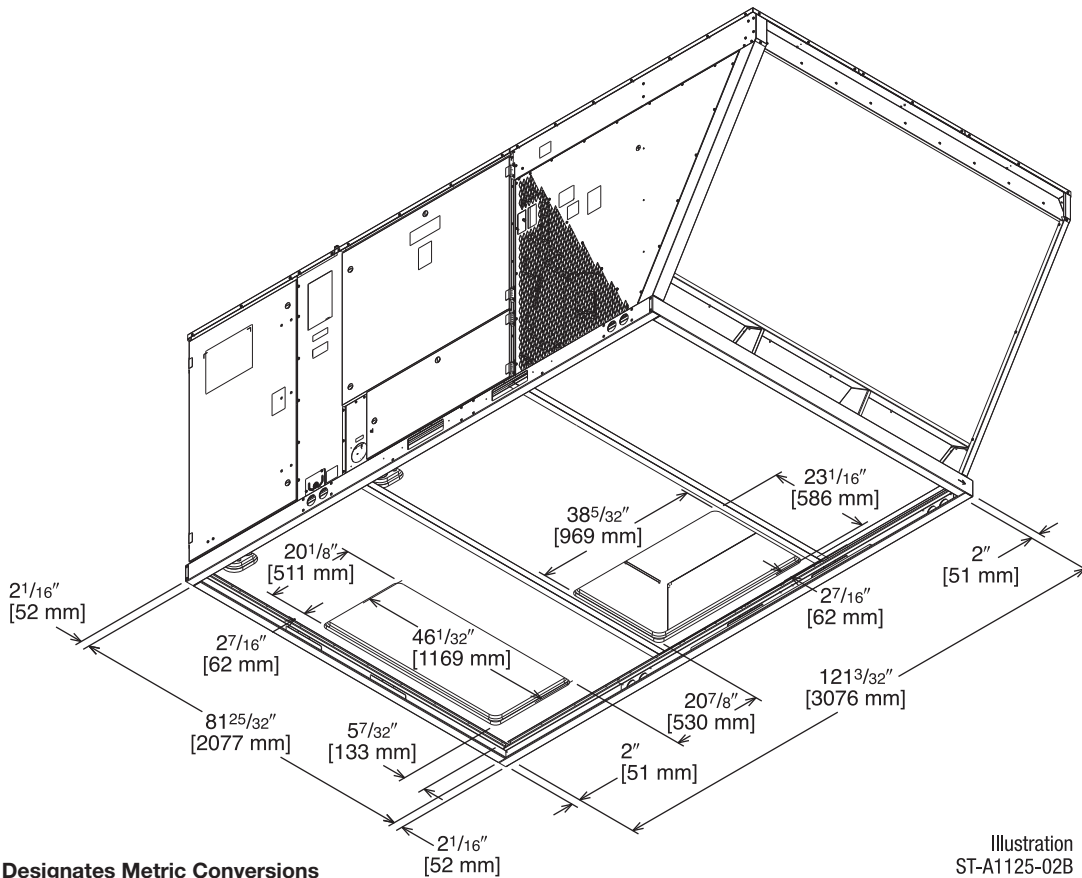
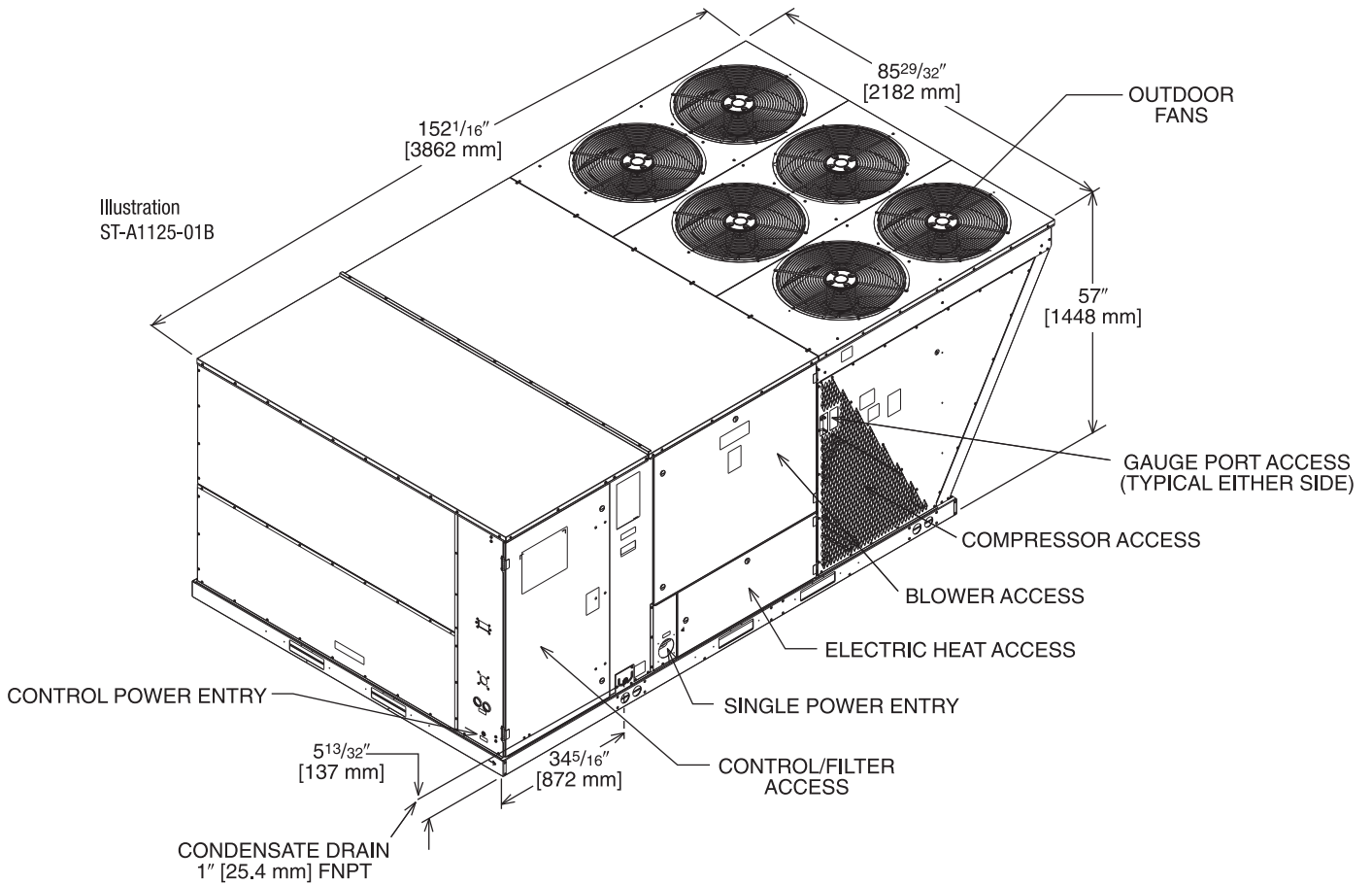

[] Designates Metric Conversions

SUPPLY AND RETURN DIMENSIONS FOR HORIZONTAL APPLICATIONS

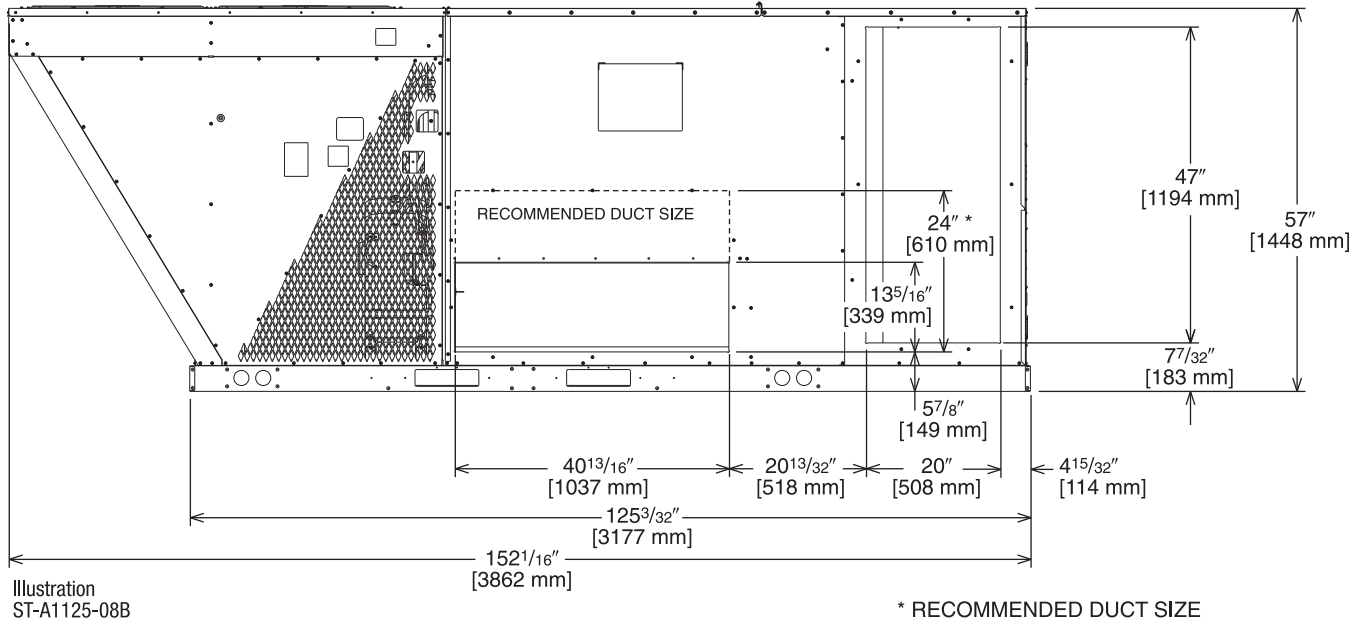

DUCT SIDE VIEW (REAR)

SUPPLY AND RETURN DIMENSIONS FOR DOWNFLOW APPLICATIONS

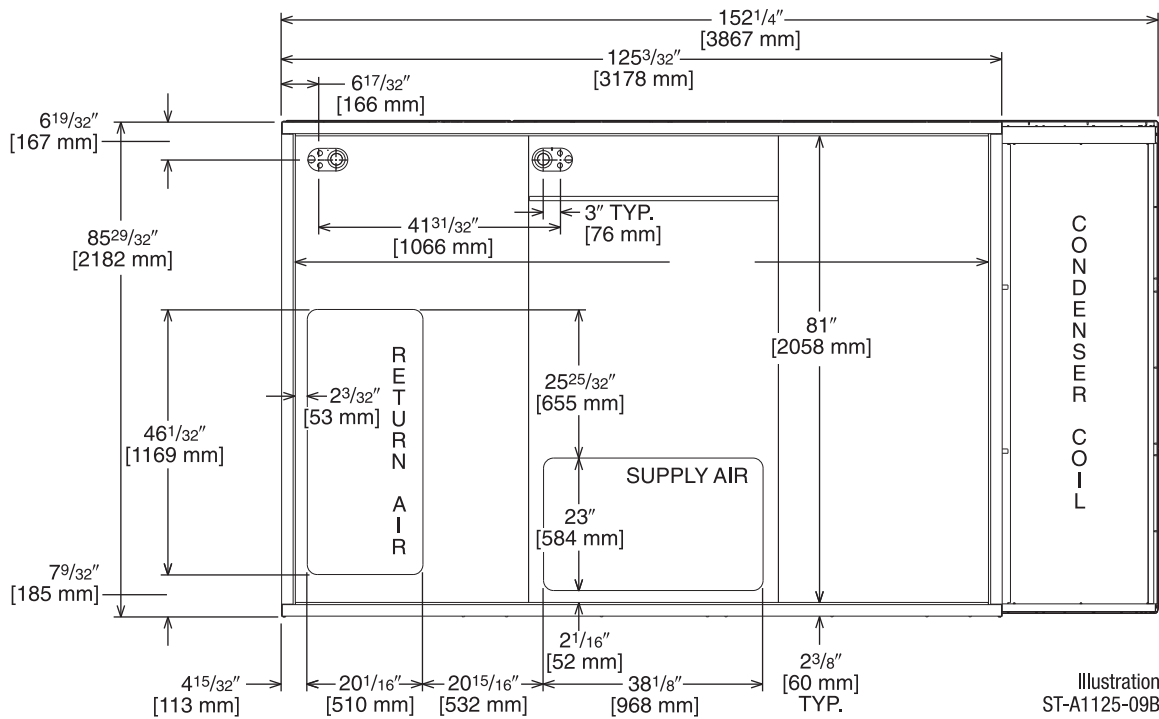

BOTTOM VIEW

[] Designates Metric Conversions

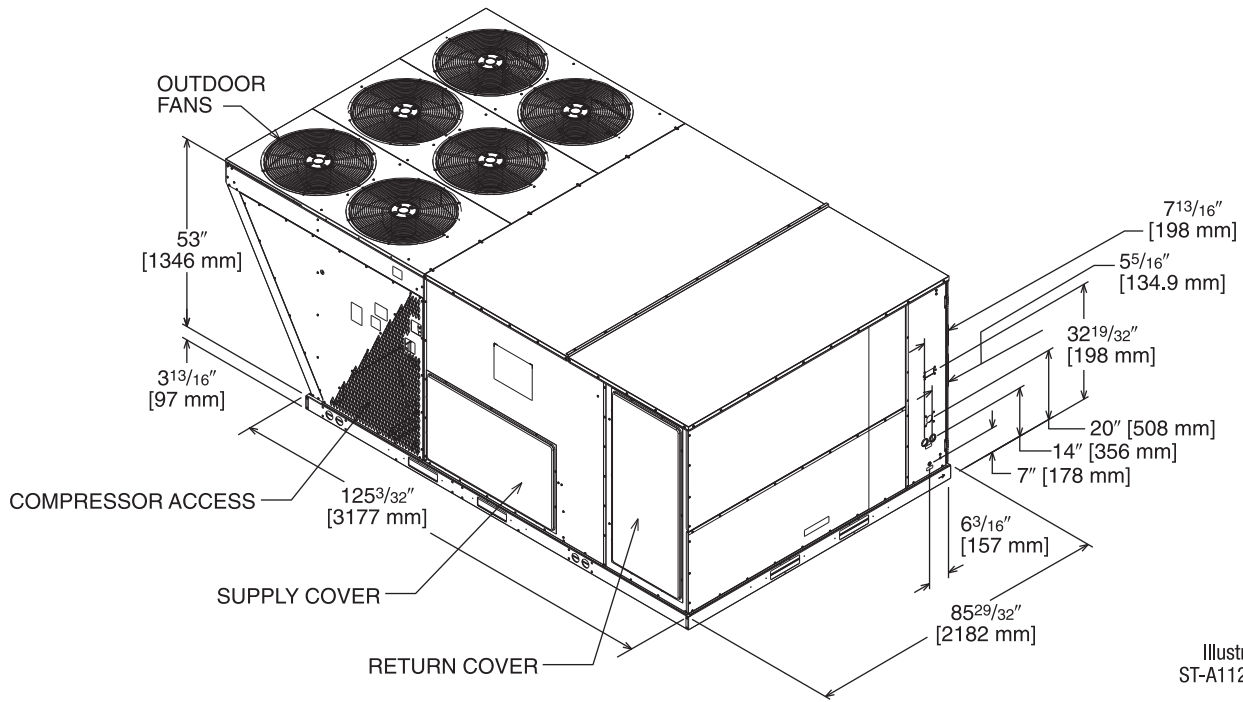
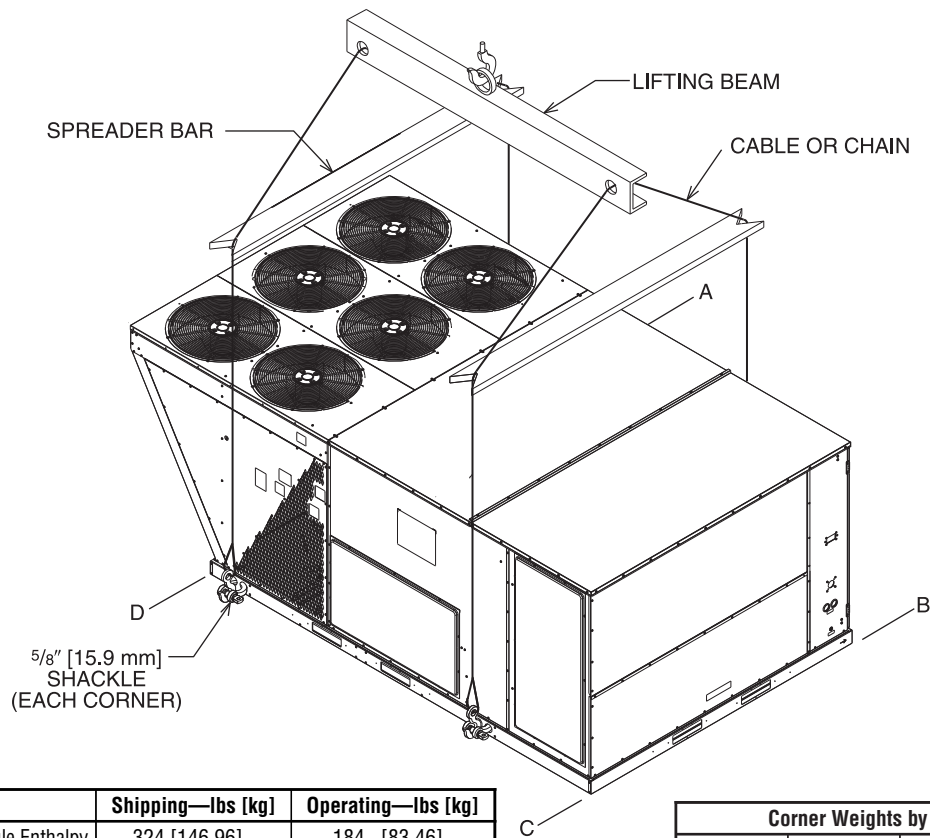

Illustration
ST-A1125-03



WEIGHTS*

Accessory	Shipping—lbs [kg]	Operating—lbs [kg]
Downflow Economizer w/DDC Single Enthalpy	324 [146.96]	184 [83.46]
Downflow Economizer w/DDC Smoke Detector	328 [148.77]	188 [85.27]
Horizontal Economizer w/DDC Single Enthalpy	367 [166.46]	258 [117.02]
Power Exhaust	44 [19.96]	42 [19.05]
Fresh Air Damper (Manual)	51 [23.13]	40 [18.14]
Fresh Air Damper (Motorized)	46 [20.87]	35 [15.88]
Roof Curb 14"	170 [77.11]	164 [74.39]

Corner Weights by Percentage			
A	B	C	D
32%	27%	16%	24%

*Note: Corner weights measured at base of unit.

[] Designates Metric Conversions

*Include options from accessory table page to obtain total unit weight.

SLAB INSTALLATION

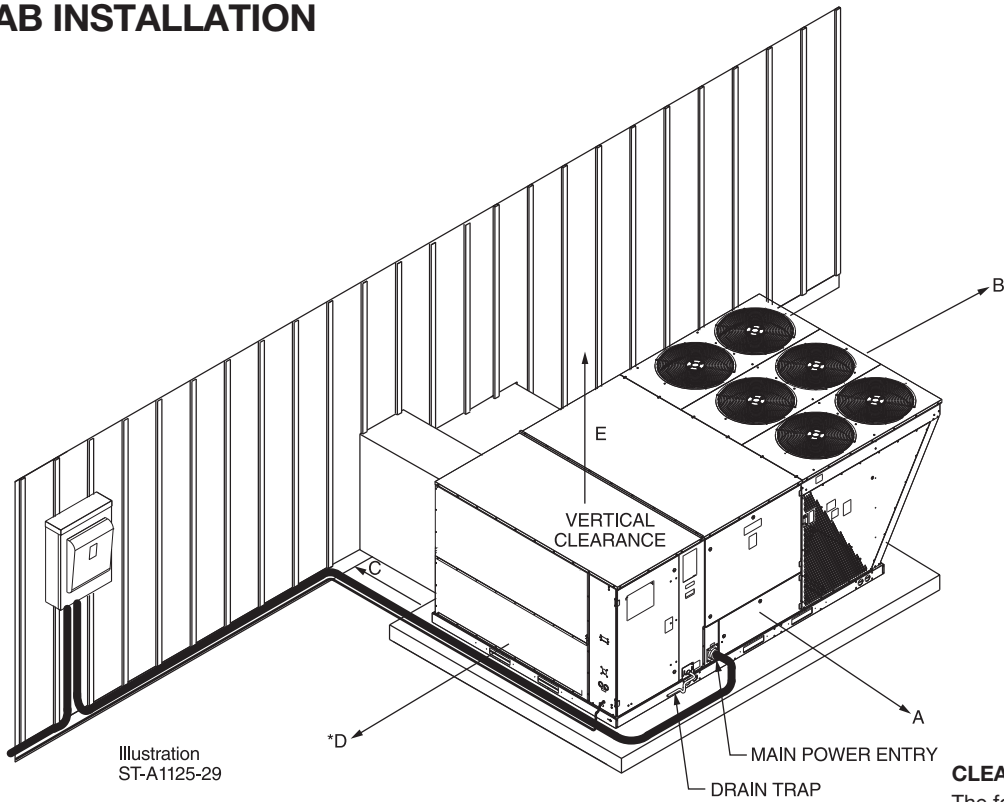

Illustration
ST-A1125-29

CLEARANCES

The following minimum clearances are recommended for proper unit performance and serviceability.

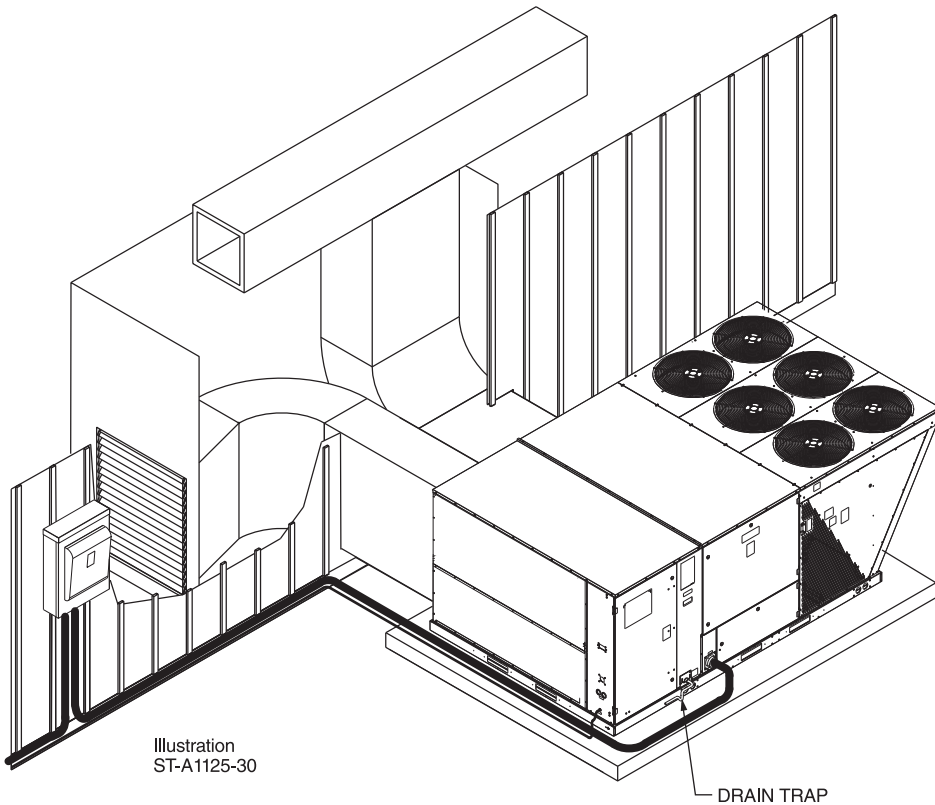

Illustration
ST-A1125-30

Recommended Clearance In. [mm]	Location
80 [2032]	A - Front
18 [457]	B - Condenser Coil
18 [457]	+C - Duct Side
18 [457]	*D - Evaporator End
60 [1524]	E - Above
*Without Economizer 18" [457 mm]. With Economizer 48" [1219 mm]. +Without Horizontal Economizer 18" [457 mm]. With Horizontal Economizer 42" [1067 mm].	

[] Designates Metric Conversions

FIELD INSTALLED ACCESSORY EQUIPMENT–SELF CONTAINED AIR CONDITIONER

Accessory	Model Number	Shipping Weight Lbs. [kg]	Installed Weight Lbs. [kg]	Factory Installation Available?
Electric Heaters	RXJJ-CE20 (C, D, Y)	41 [18.6]	31 [14.1]	Yes
	RXJJ-CE40 (C, D, Y)	44 [20.0]	34 [15.4]	Yes
	RXJJ-CE60 (C, D, Y)	45 [20.4]	35 [15.9]	Yes
	RXJJ-CE75 (C, D, Y)	46 [20.8]	36 [16.3]	Yes
Downflow Economizer w/Single Enthalpy (DDC)	AXRD-01RGDAM3	277 [125.6]	168 [76.2]	Yes
Downflow Economizer w/Smoke Detector (DDC)	AXRD-01RGDBM3	280 [127.0]	171 [77.6]	Yes
Dual Enthalpy Kit	RXR-AV04	1 [.5]	.5 [0.2]	No
Horizontal Economizer w/Single Enthalpy (DDC)	AXRD-01RGHAM3	333 [151.0]	301 [36.5]	No
Carbon Dioxide Sensor (Wall Mount)	RXR-AR02	3 [1.4]	2 [1.0]	No
Power Exhaust (208/230V)	RXR-BGF05C	119 [54.0]	59 [26.8]	No
Power Exhaust (460V)	RXR-BGF05D	119 [54.0]	59 [26.8]	No
Manual Fresh Air Damper*	AXRF-KFA1	61 [27.7]	52 [23.6]	No
Motorized Kit for Manual Fresh Air Damper*	RXR-AW03	42 [19.1]	35 [15.9]	No
Modulating Motor Kit w/position feedback for RXRF-KFA1	RXR-AW05	45 [20.4]	38 [17.2]	No
Roofcurb, 14"	RXKG-CBH14	184 [83.5]	176 [79.8]	No
Roofcurb Adapter to RXR-E56	RXR-CJCE56	465 [210.9]	415 [88.2]	No
Roofcurb Adapter to RXKG-CAF14	RXR-CJCF14	555 [251.7]	505 [29.1]	No
Concentric Diffuser (Step-Down, 18" x 36")	RXR-AD81	310 [140.6]	157 [71.2]	No
Concentric Diffuser (Step-Down, 24" x 48")	RXR-AD86	367 [166.5]	212 [96.2]	No
Concentric Diffuser (Step-Down, 28" x 60")	RXR-AD88	410 [186.0]	370 [67.8]	No
Concentric Diffuser (Flush, 18" x 36")	RXR-AD80	213 [96.6]	115 [52.2]	No
Downflow Transition (Rect. to Rect., 18" x 36")	RXMC-CJ07	81 [36.7]	74 [33.6]	No
Downflow Transition (Rect. to Rect., 24" x 48")	RXMC-CK08	81 [36.7]	74 [33.6]	No
Downflow Transition (Rect. to Rect., 28" x 60")	RXMC-CL09	81 [36.7]	74 [33.6]	No
Low-Ambient Control Kit (1 Per Compressor)	RXR-C02	3 [1.4]	2 [0.9]	Yes
Unwired Convenience Outlet	RXR-AN01	2 [0.9]	1.5 [.7]	Yes
Unfused Service Disconnect+	RXR-AP01	10 [4.5]	9 [4.1]	Yes
Comfort Alert (1 per Compressor)	RXR-AZ01	3 [1.4]	2 [0.9]	Yes
BACnet Communication Card	RXR-AY01	1 [0.5]	1 [0.5]	No
LonWorks Communication Card	RXR-AY02	1 [0.5]	1 [0.5]	No
Room Humidity Sensor	RHC-ZNS4	1 [0.5]+	1 [0.5]+	No*
Room Temperature and Relative Humidity Sensor	RHC-ZNS5	1 [0.5]+	1 [0.5]+	No*
Hail Guard Louvers	AXRX-AAD01L	55 [24.8]	45 [20.3]	Yes
MERV 8 Filter	RXMF-M08A22520	2 [0.9]	1 [0.45]	No
MERV 13 Filter	RXMF-M13A22520	2 [0.9]	1 [0.45]	No

*Motorized Kit and Manual Fresh Air Damper must be combined for a complete Motorized Outside Air Damper Selection.

[] Designates Metric Conversions

FLUSH MOUNT ROOM TEMPERATURE SENSORS FOR NETWORKED DDC APPLICATIONS



ROOM TEMPERATURE SENSOR RHC-ZNS1
with TIMED OVERRIDE BUTTON

10k Ω room temperature sensor transmits room temperature to DDC system. Timed override button allows tenant to change from unoccupied temperature setpoint to occupied temperature setpoint for a preset time.



ROOM TEMPERATURE SENSOR RHC-ZNS2
with TIMED OVERRIDE BUTTON and STATUS INDICATOR

10k Ω room temperature sensor transmits room temperature to DDC system. Timed override button allows tenant to change from unoccupied temperature setpoint to occupied temperature setpoint for a preset time. Status Indicator Light transmits ALARM flash code to occupied space.



ROOM TEMPERATURE SENSOR RHC-ZNS3
with SETPOINT ADJUSTMENT and TIMED OVERRIDE BUTTON

10k Ω room temperature sensor with setpoint adjustment transmits room temperature to DDC system along with desired occupied room temperature setpoint. Timed override button allows tenant to change from unoccupied temperature setpoint to occupied temperature setpoint for a preset time.

COMMUNICATION CARDS

Field Installed



BACnet® COMMUNICATION CARD RXRX-AY01

The field installed BACnet® Communication Card allows the RTU-C unit controller to communicate with a third party building management system that supports the BACnet Application Specific Controller device profile. The BACnet® Communication Module plugs onto the unit RTU-C controller and allows communication between the RTU-C and the BACnet MSTP network.



LonWorks® COMMUNICATION CARD RXRX-AY02

The field installed LonWorks® Communication Card allows the RTU-C unit controller to communicate with a third party building management system that supports the LonMark Space Comfort Controller (SCC) functional profile or LonMark Discharge Air Controller (DAC) functional profile. The LonMark Communication Module plugs onto the RTU-C controller and allows communication between the RTU-C and a LonWorks Network.

ECONOMIZERS—DOWNFLOW ONLY

Use to Select Field Installed Options Only

AXRD-01RMDCM3—Single Enthalpy (Outdoor) with DDC

AXRD-01RMDDM3—Single Enthalpy (Outdoor) w/Smoke Detector and DDC

RXR-AR02—Optional Wall-Mounted CO₂ Sensor

RXR-AV04—Dual Enthalpy Upgrade Kit

- Features **Honeywell** Controls
- Available Factory Installed or Field Accessory
- Gear Driven Direct Drive Actuator
- Fully Modulating (0-100%)
- Ultra Low Leak Dampers meet California Title 24 requirements
- Slip-In Design for Easy Installation
- Plug-In Polarized 12-pin & 4-pin Electrical Connections
- Pre-Configured—No Field Adjustments Necessary
- Standard Barometric Relief Damper
- Single Enthalpy with Dual Enthalpy Upgrade Kit Available
- CO₂ Input Sensor Available
- Field Assembled Hood Ships with Economizer
- Economizer Ships Complete for Downflow Duct Application
- Optional Remote Minimum Position Potentiometer (270 ohm) (Honeywell #S963B1136) is Available from Prostock
- Field Installed Power Exhaust Available
- If connected to a Building Automation System (BAS), all economizer functions can be viewed on the (BAS)

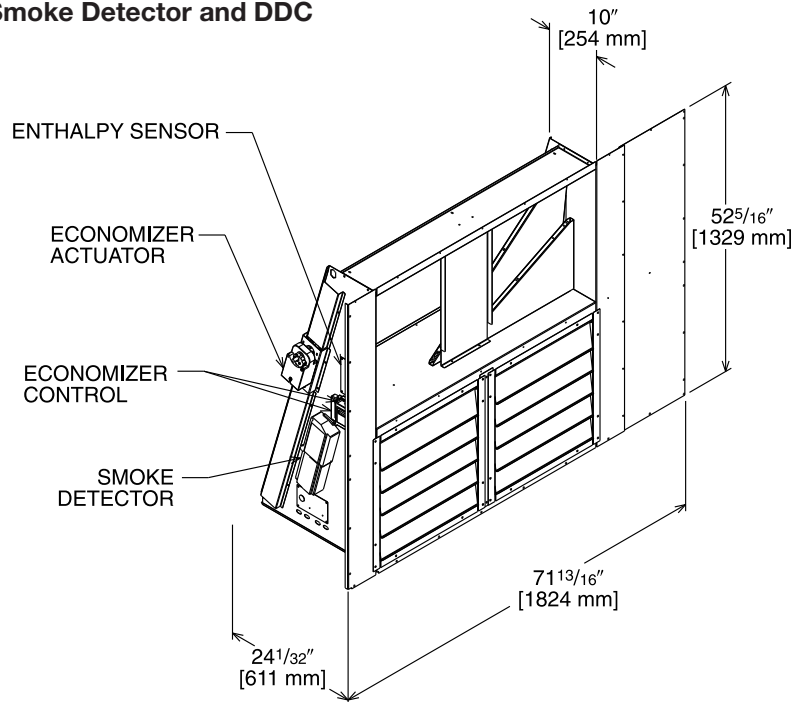

Illustration
ST-A00566-58

TOLERANCE ±.125

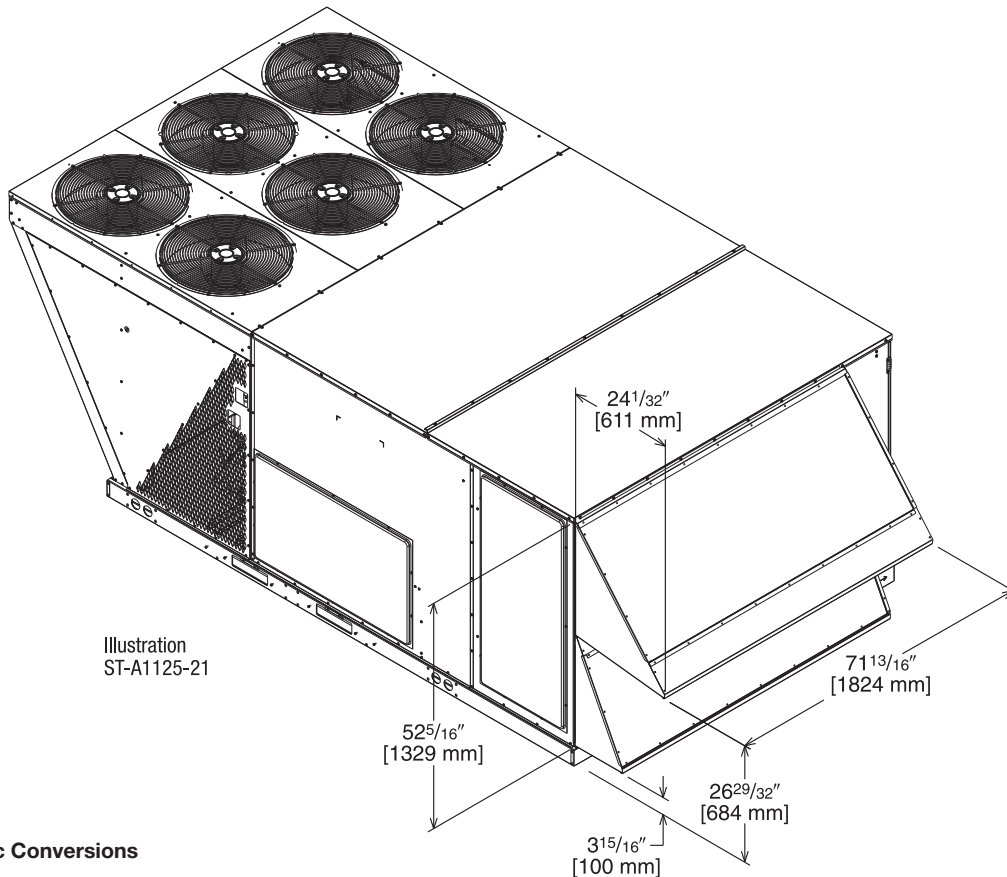

Illustration
ST-A1125-21

[] Designates Metric Conversions

ECONOMIZER FOR HORIZONTAL DUCT INSTALLATION

Field Installed Only

AXRD-01RMHCM3—Single Enthalpy (Outdoor) with DDC
RXXR-AV04—Dual Enthalpy Upgrade Kit
RXXR-AR02—Optional Wall-Mounted CO₂ Sensor

- Features **Honeywell** Controls
- Available as a Field Installed Accessory Only
- Gear Driven Direct Drive Actuator
- Fully Modulating (0-100%)
- Ultra Low Leak Dampers meet California Title 24 requirements
- Slip-In Design for Easy Installation
- Plug-In Polarized 12-pin and 4-pin Electrical Connections
- Pre-Configured—No Field Adjustments Necessary
- Standard Barometric Relief Damper
- Single Enthalpy with Dual Enthalpy Upgrade Kit Available
- CO₂ Input Sensor Available
- Field Assembled Hood Ships with Economizer
- Economizer Ships Complete for Horizontal Duct Application
- Optional Remote Minimum Position Potentiometer (270 ohm) (Honeywell #S963B1136) is available from Prostock
- Field Installed Power Exhaust Available
- If connected to a Building Automation System (BAS), all economizer functions can be viewed on the (BAS) or 16 x 2 LCD screen
- If connected to thermostat, all economizer functions can be viewed on 16 x 2 character LCD screen

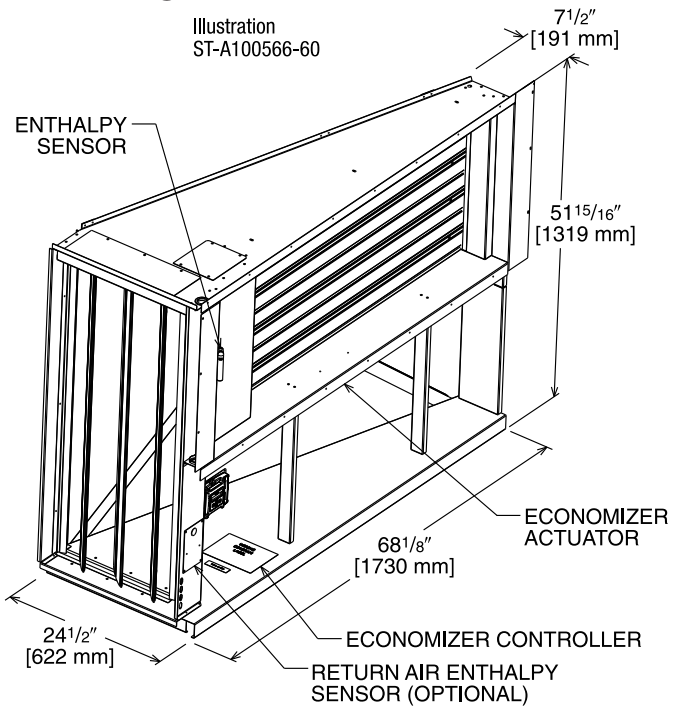

TOLERANCE ± .125

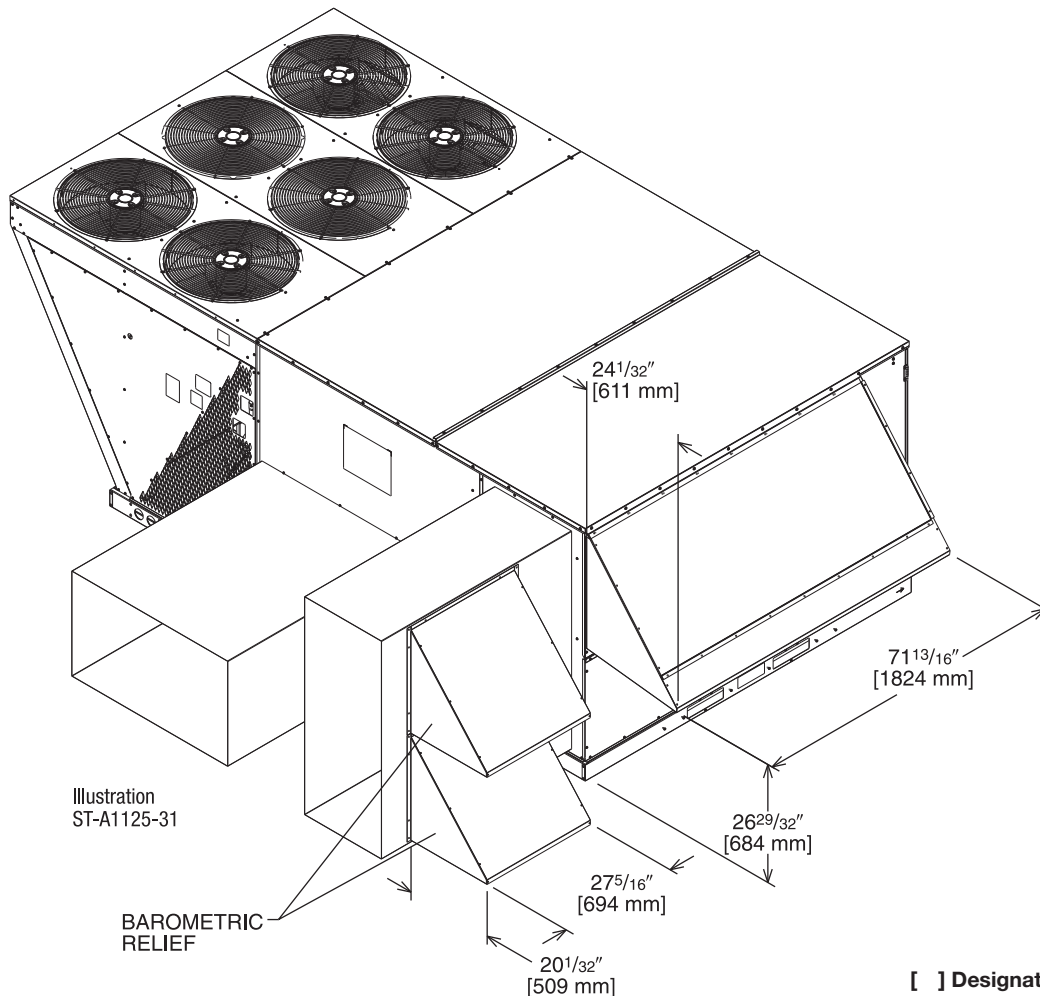

[] Designates Metric Conversions

INTEGRAL POWER EXHAUST KIT FOR AXRD-PMCM3 OR SMCM3 ECONOMIZERS

RXXR-BGF05 (C, D, or Y*)

*Voltage Code

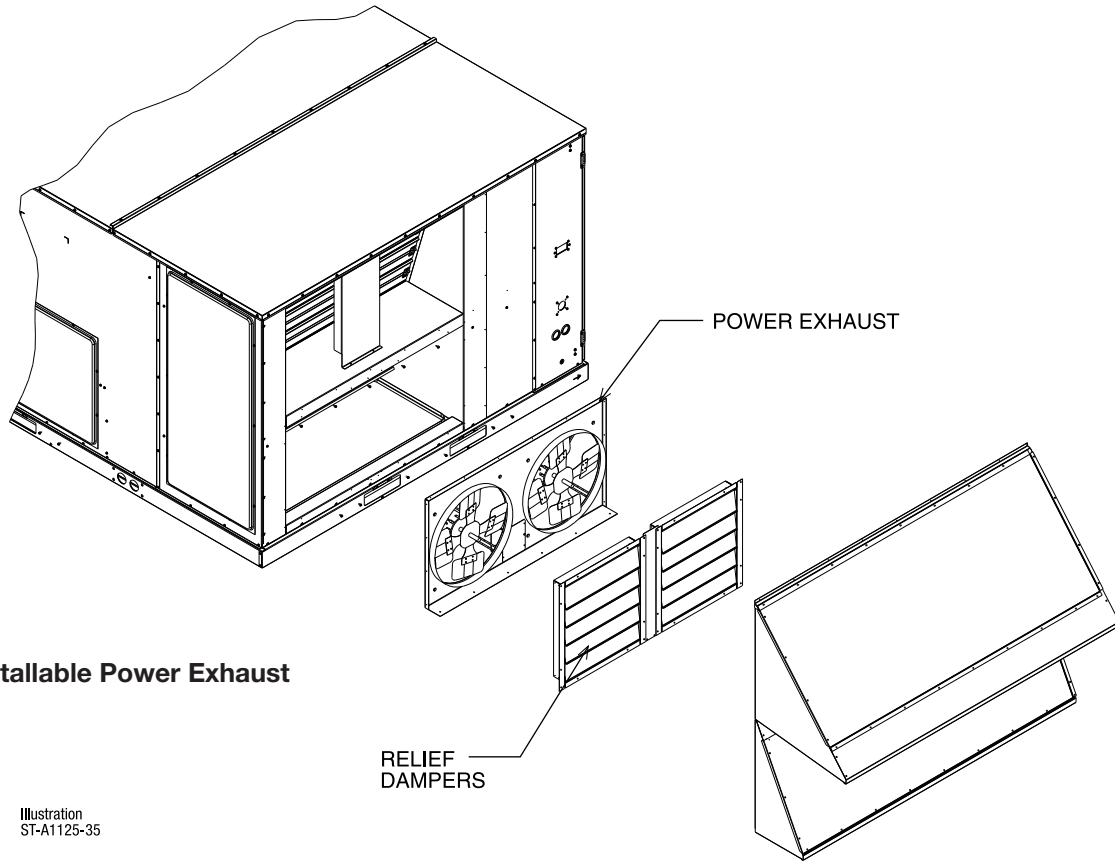

Field Installable Power Exhaust

Illustration
ST-A1125-35

Model No.	No. of Fans	Volts	Phase	HP (ea.)	Low Speed		High Speed ①		FLA (ea.)	LRA (ea.)
					CFM [L/s] ②	RPM	CFM [L/s] ②	RPM		
RXXR-BGF05C	2	208-230	1	0.75	4100 [1935]	850	5200 [2454]	1050	5	4.97
RXXR-BGF05D	2	460	1	0.75	4100 [1935]	850	5200 [2454]	1050	2.2	3.4
RXXR-BGF05Y	2	575	1	0.75	4100 [1935]	850	5200 [2454]	1050	1.5	2.84

NOTES: ① Power exhaust is factory set on high speed motor tap.

② CFM is per fan at 0" w.c. external static pressure.

[] Designates Metric Conversions

FRESH AIR DAMPER

MOTORIZED DAMPER KIT RXRX-AW03 (Motor Kit for AXRF-KFA1)

RXRX-AW05 (Modulating Motor Kit with position feedback for AXRF-KFA1)

- Features **Honeywell** Controls
- Gear Driven Direct Drive Actuator
- Fully Modulating (0-100%)
- Low Leakage Dampers
- Slip-In Design for Easy Installation
- Plug-In Polarized 12-pin and 4-pin Electrical Connections
- Pre-Configured—No Field Adjustments Necessary
- Addition of Dual Enthalpy Upgrade Kit allows limited economizer function
- CO₂ Sensor Input Available for Demand Control Ventilation (DCV)
- Optional Remote Minimum Position Potentiometer (270 ohm) (Honeywell #S963B1136) is available from Prostock
- All fresh air damper functions can be viewed at the RTU-C unit controller display
- If connected to a Building Automation System (BAS), all fresh air damper functions can be viewed on the (BAS), on 16 x 2 LCD screen
- If connected to thermostat, all fresh air damper functions can be viewed on 16 x 2 LCD screen

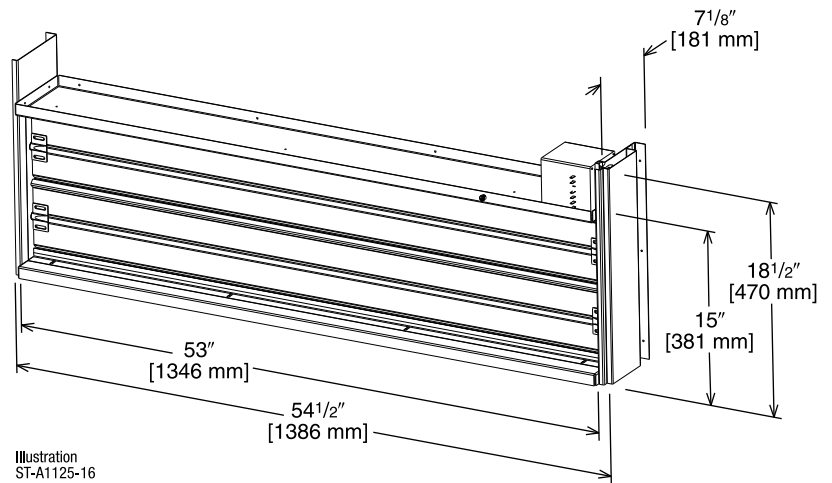

Illustration
ST-A1125-16

AXRF-KFA1 (Manual)

RXRX-AW03 (Motorized damper kit for manual fresh air damper)

RXRX-AW05 (Modulating Motor Kit with position feedback for AXRF-KFA1)

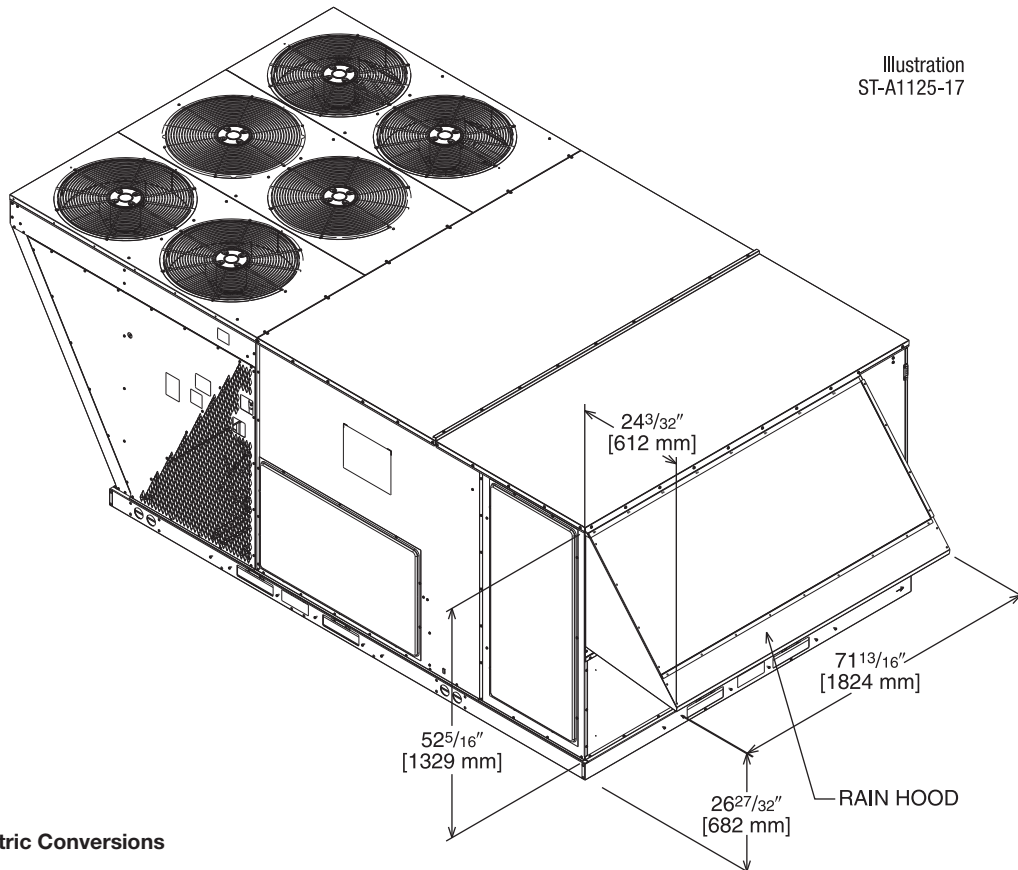

Illustration
ST-A1125-17

[] Designates Metric Conversions

ROOFCURBS (Full Perimeter)

- Friedrich®'s roofcurb design can be utilized on 15, 17.5, 20 and 25 ton [52.8, 61.5, 70.3 and 87.9 kW] models.
- One available height (14" [356 mm]).
- Quick assembly corners for simple and fast assembly.
- 1" [25.4 mm] x 4" [102 mm] Nailers provided.
- Insulating panels not required because of insulated outdoor base pan.
- Sealing gasket (28" [711 mm]) provided with Roofcurb.
- Packaged for easy field assembly.

TYPICAL INSTALLATION

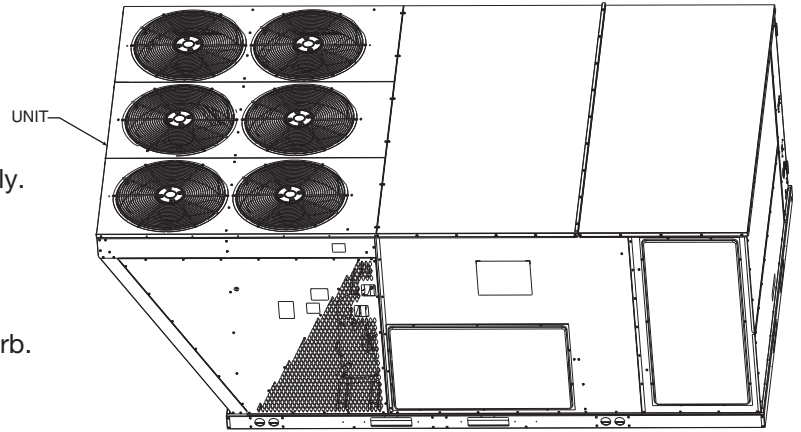

ROOFCURB ASSEMBLY

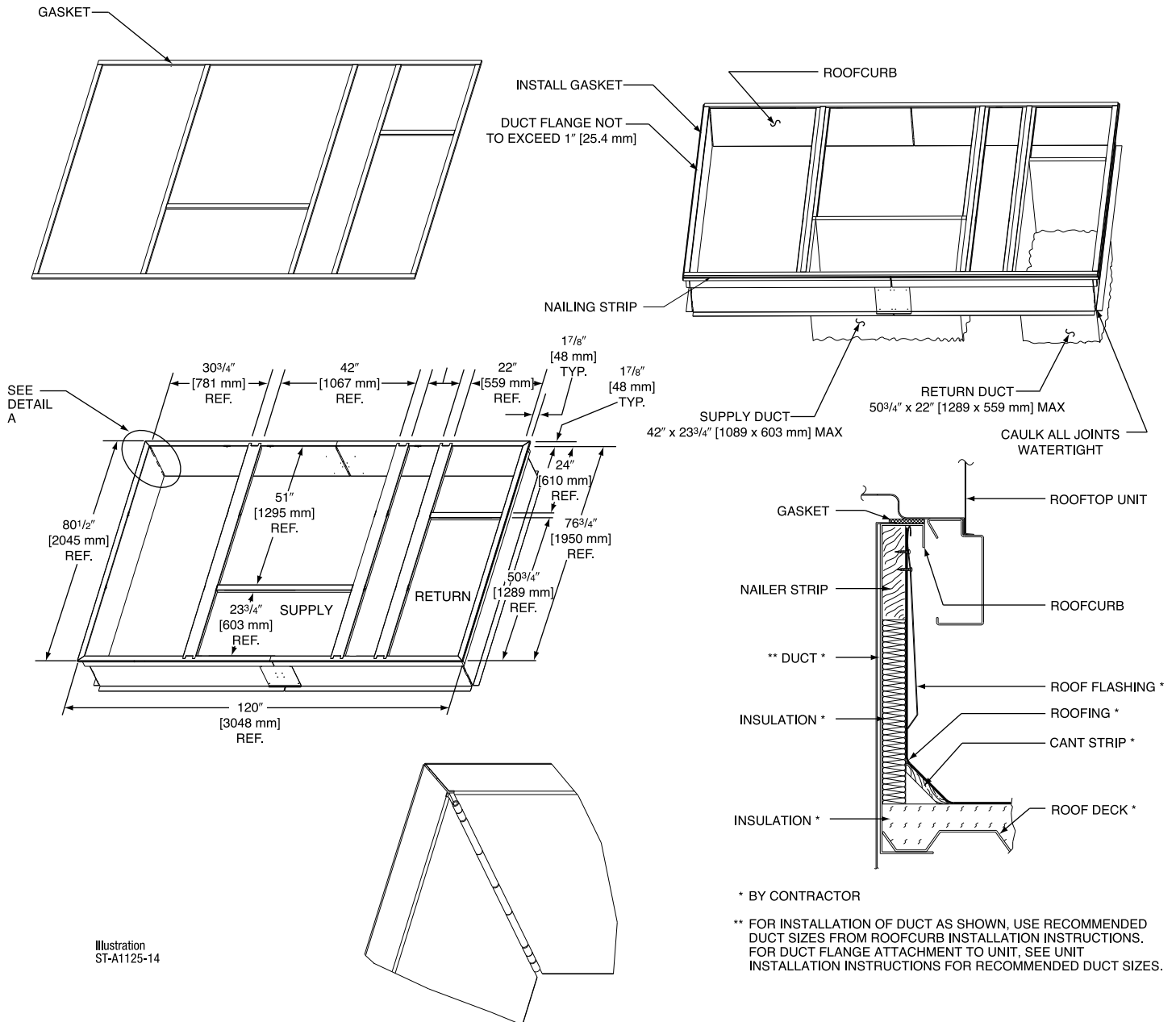

[] Designates Metric Conversions

ROOFCURB ADAPTERS

OLD MODELS
COMMERCIAL CABINET
(12.5, 15 & 20 TON)
([44, 52.8 & 70.3 kW])
(-)RCF, (-)RGF, (-)REF

OLD CURB MODEL

ROOFCURB ADAPTER

NEW MODEL

RXRK-E56

RXRK-CJCE56

RLNL-C/H
(15, 17.5, 20 & 25 TON)
([52.8, 61.5, 70.3 & 87.9 kW])

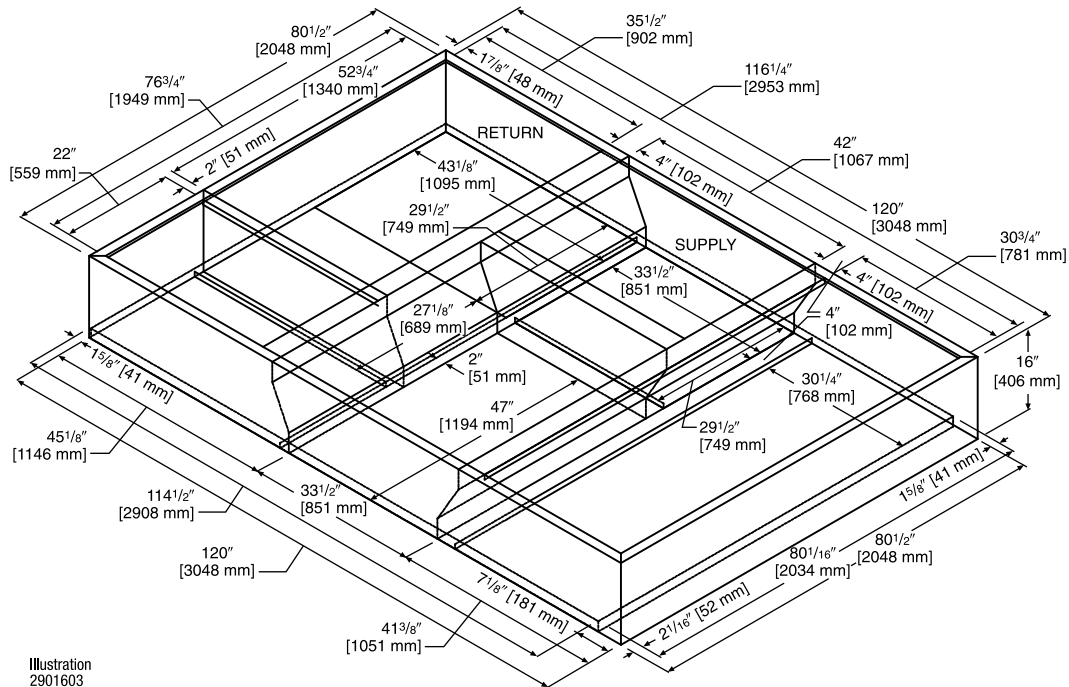

COMMERCIAL CABINET
(15, 20 & 25 TON)
([52.8, 70.3 & 87.9 kW])
(-)LKB, LMB, LNB

RXKG-CAF14

RXRK-CJCF14

RLNL-C/H
(15, 17.5, 20 & 25 TON)
([52.8, 61.5, 70.3 & 87.9 kW])

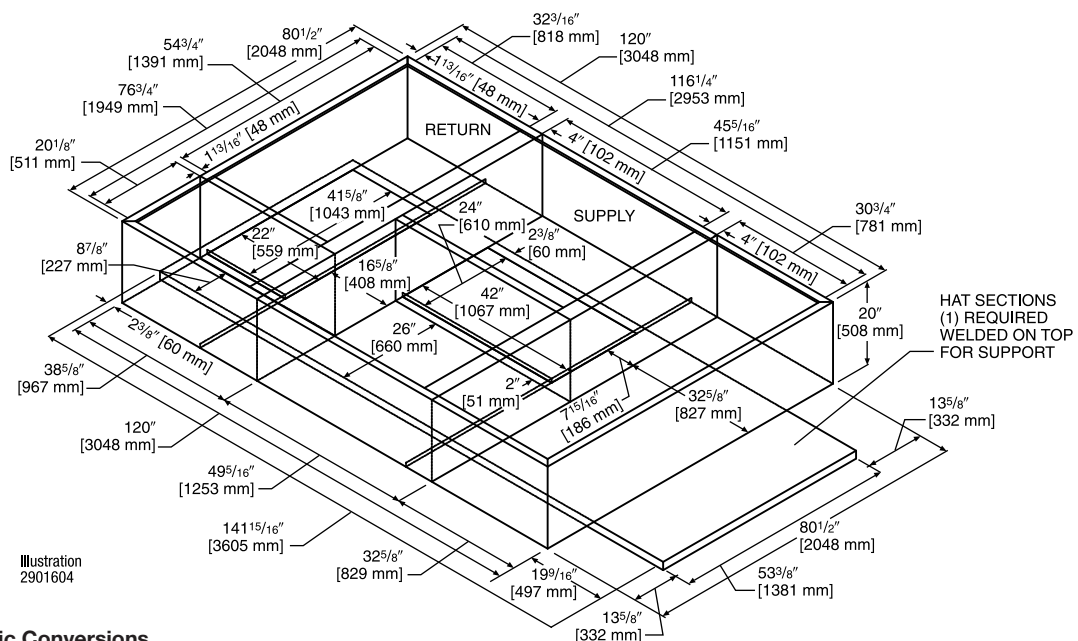

[] Designates Metric Conversions

CONCENTRIC DIFFUSER APPLICATION

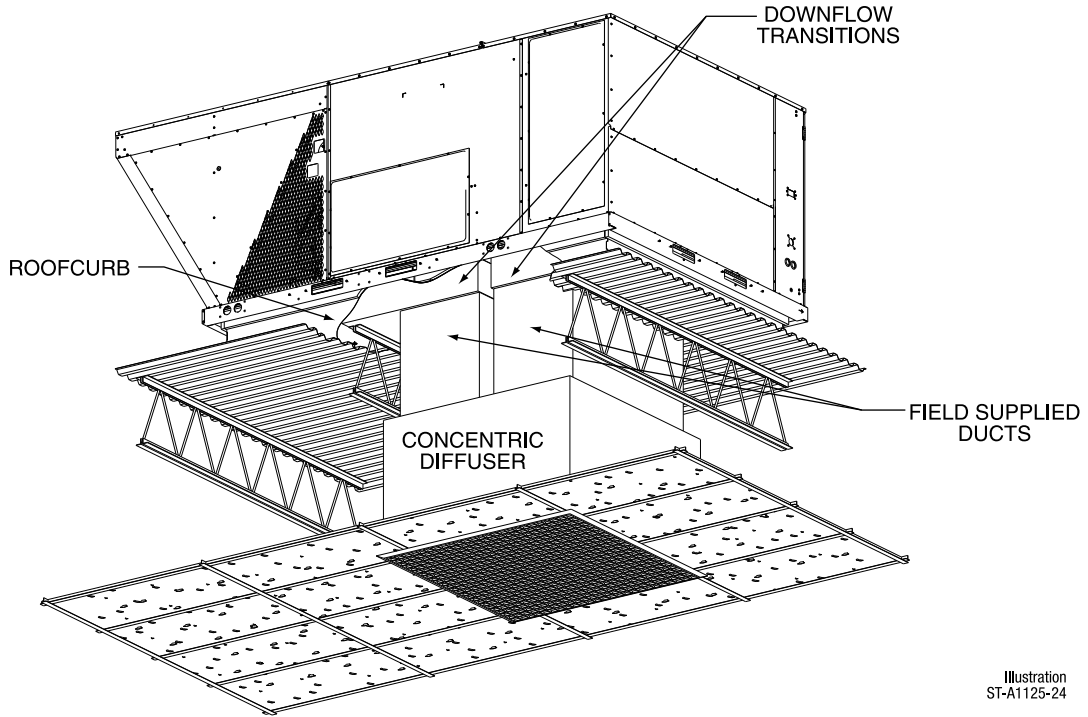

Illustration
ST-A1125-24

DOWNFLOW TRANSITION DRAWINGS

RXMC-CJ07 (15 Ton) [52.8 kW]

- Used with RXRN-AD80 and RXRN-AD81 Concentric Diffusers

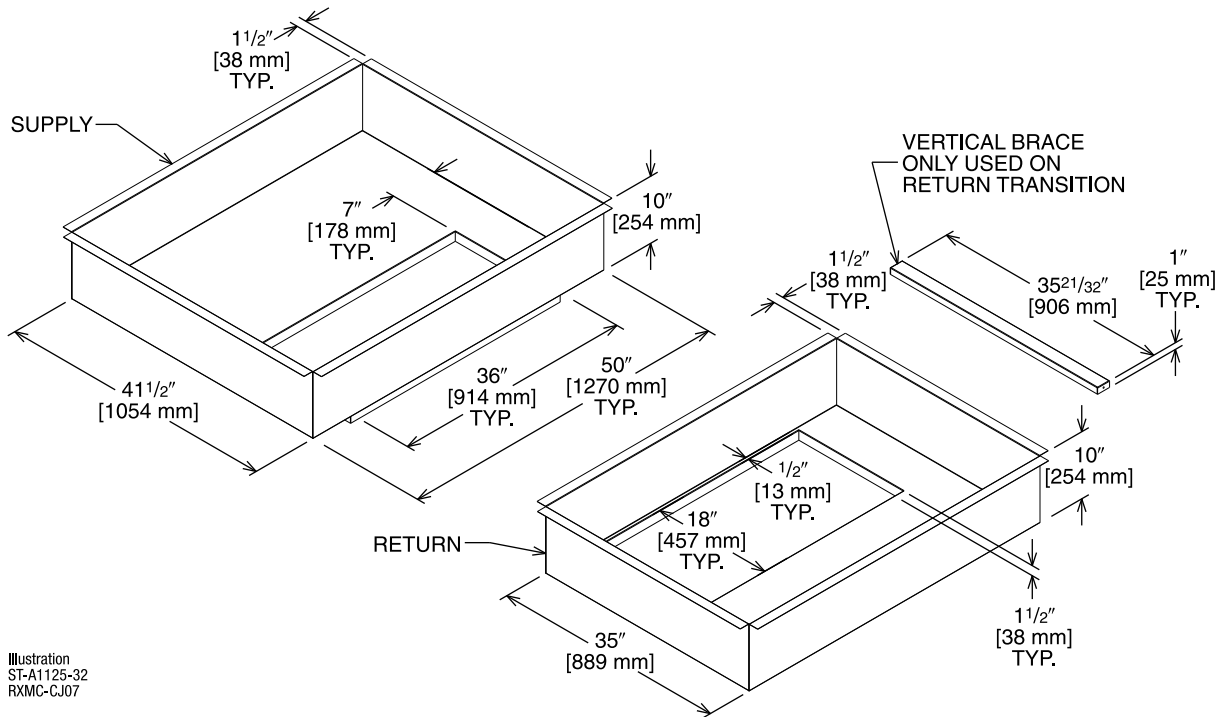

Illustration
ST-A1125-32
RXMC-CJ07

[] Designates Metric Conversions

DOWNFLOW TRANSITION DRAWINGS (Cont.)

RXMC-CK08 (20 Ton) [70.3 kW]

- Used with RXRN-AD86 Concentric Diffusers

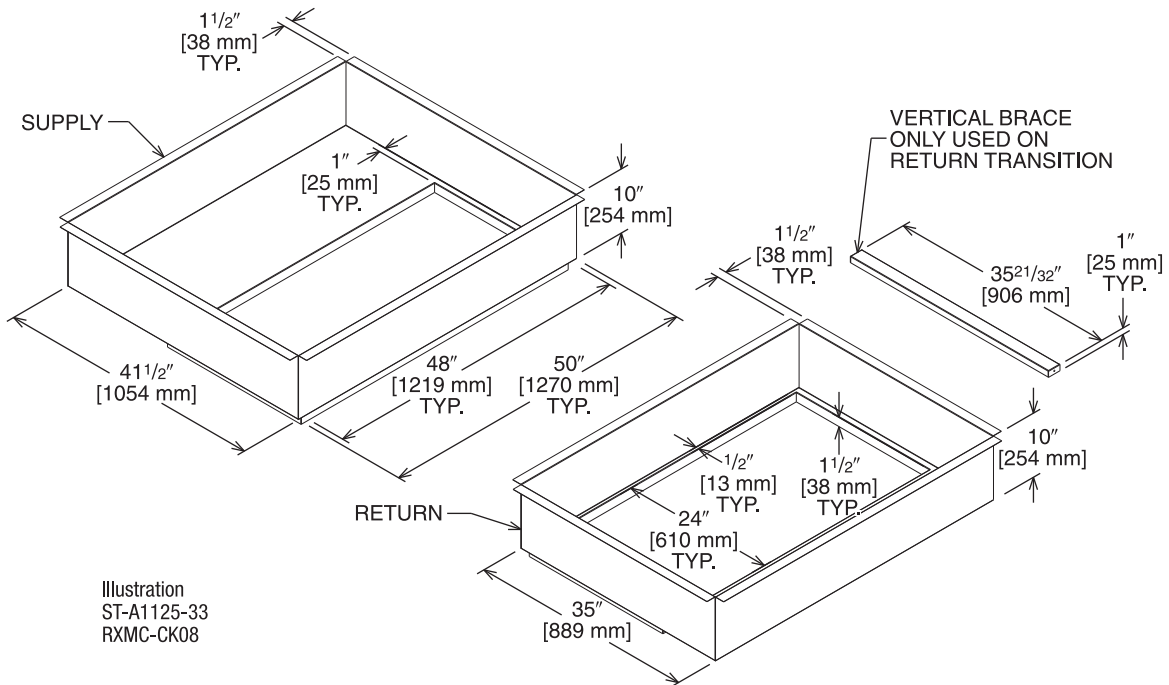

RXMC-CL09 (25 Ton) [87.9 kW]

- Used with RXRN-AD88 Concentric Diffusers

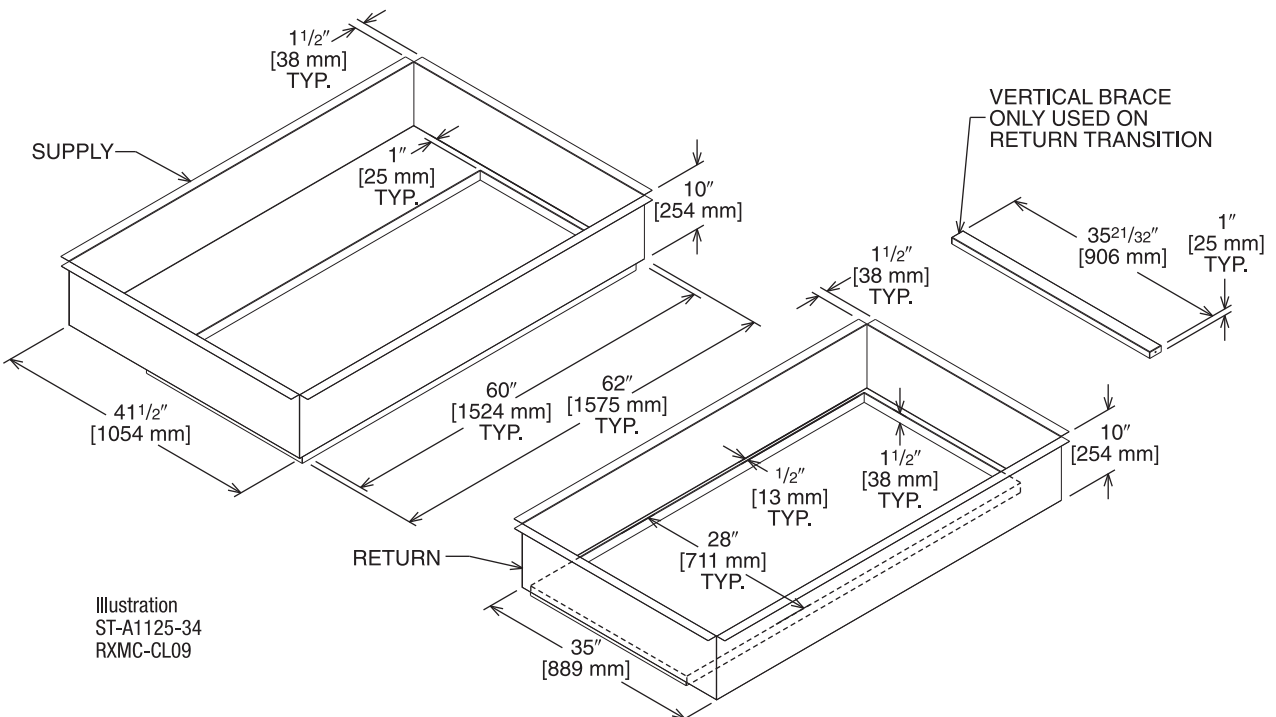

[] Designates Metric Conversions

CONCENTRIC DIFFUSER 15 TON [52.8 kW] FLUSH

- All aluminum diffuser with aluminum return air eggcrate.
- Built-in anti-sweat gasket.
- Molded fiberglass supports.
- Built-in hanging supports.
- Diffuser box constructed of sheetmetal insulated with 1" [25.4 mm] 1.5 lbs. [.7 kg] duct liner.

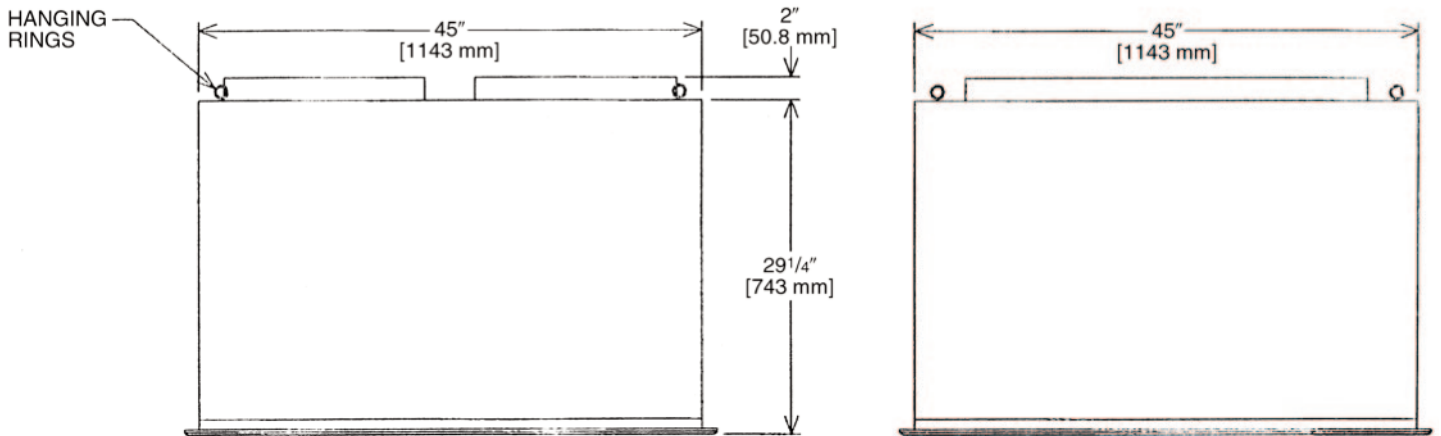
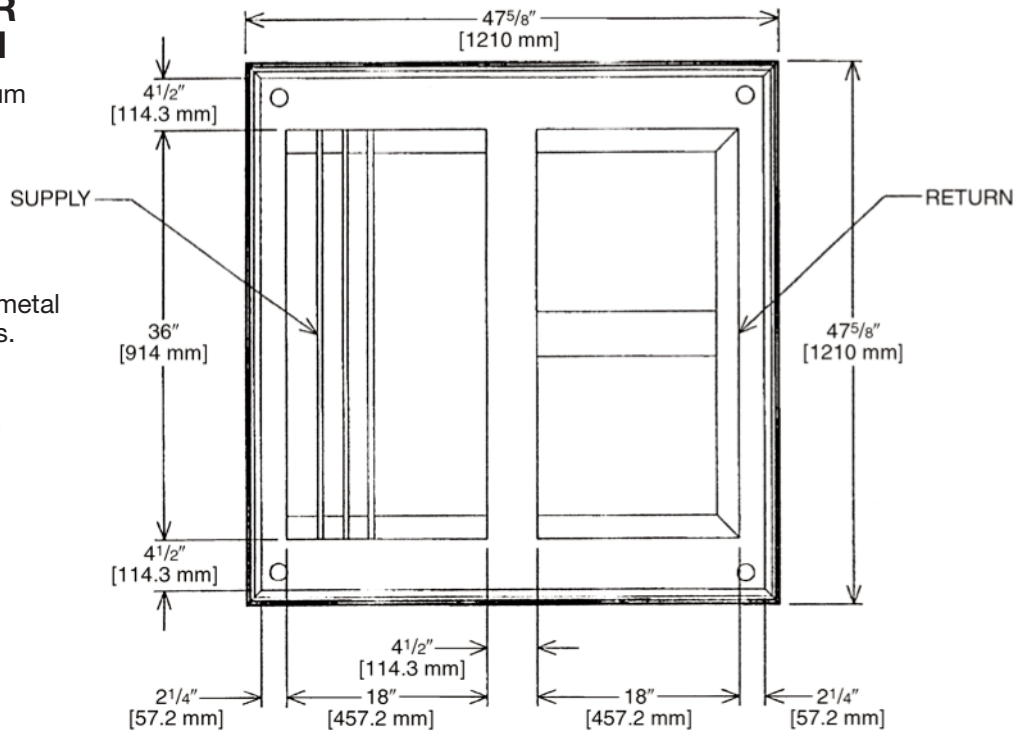

CONCENTRIC DIFFUSER SPECIFICATIONS

PART NUMBER	CFM [L/s]	STATIC PRESSURE	THROW FEET	NECK VELOCITY	JET VELOCITY
RXRN-AD80	5600 [2643]	0.36	28-37	1000	2082
	5800 [2737]	0.39	29-38	1036	2156
	6000 [2832]	0.42	40-50	1071	2230
	6200 [2926]	0.46	42-51	1107	2308
	6400 [3020]	0.50	43-52	1143	2379
	6600 [3115]	0.54	45-56	1179	2454

[] Designates Metric Conversions

CONCENTRIC DIFFUSER 15 TON [52.8 kW] STEP DOWN

- All aluminum diffuser with aluminum return air eggcrate.
- Built-in anti-sweat gasket.
- Molded fiberglass supports.
- Built-in hanging supports.
- Diffuser box constructed of sheetmetal insulated with 1" [25.4 mm] 1.5 lbs. [.7 kg] duct liner.
- Double deflection diffuser with the blades secured by spring steel.

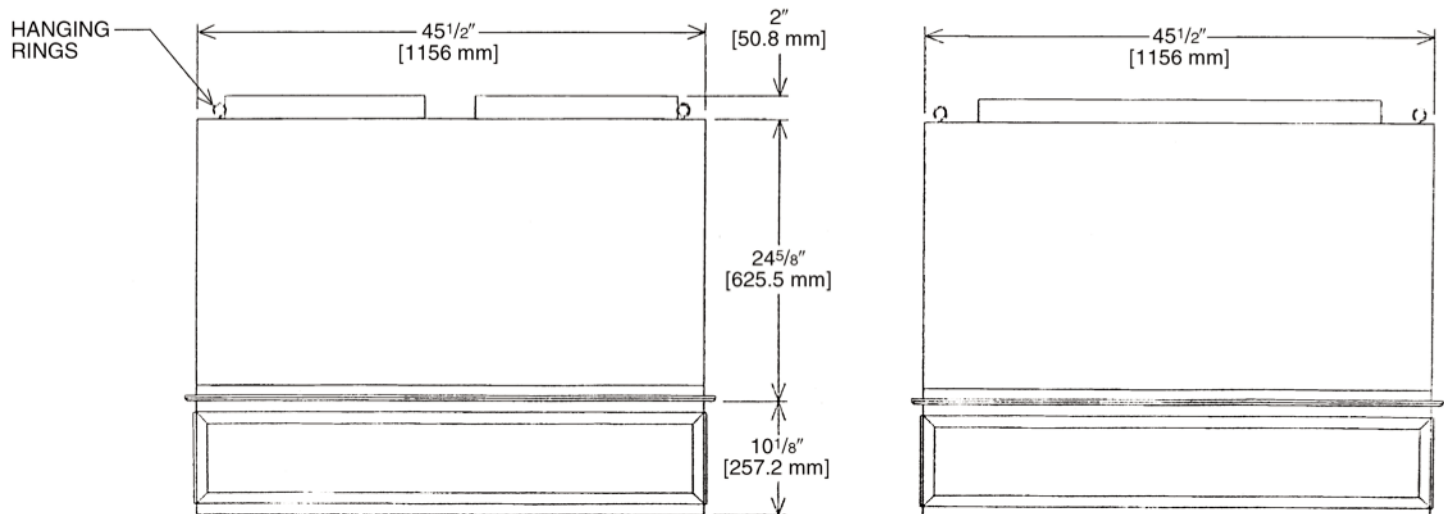
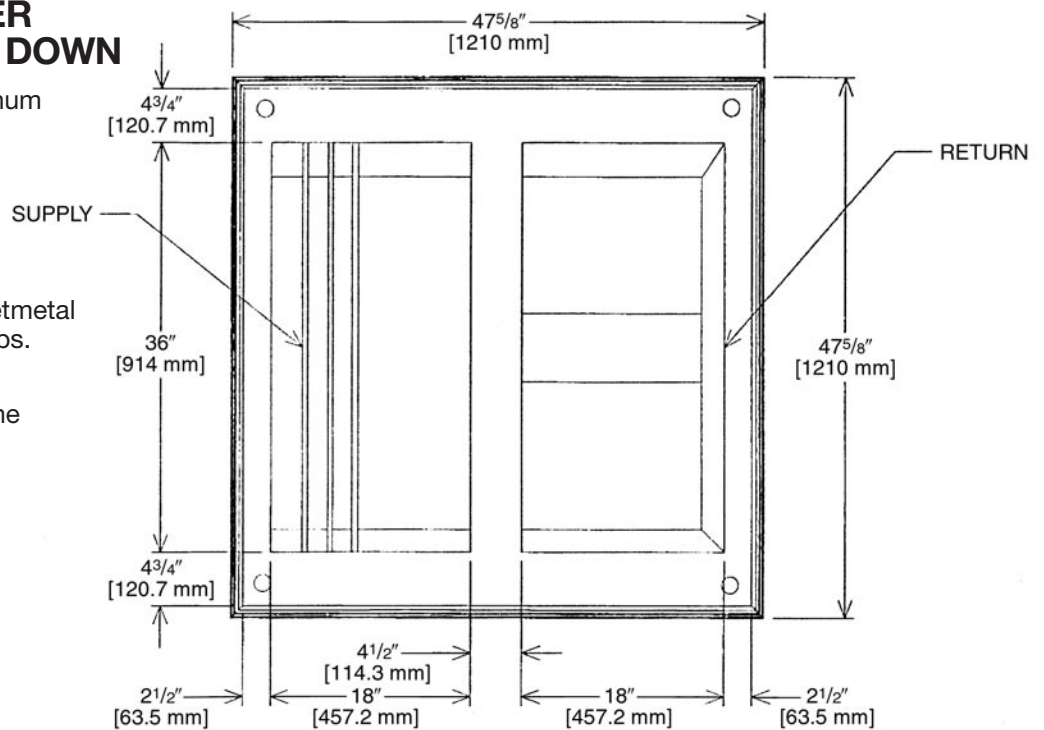

CONCENTRIC DIFFUSER SPECIFICATIONS

PART NUMBER	CFM [L/s]	STATIC PRESSURE	THROW FEET	NECK VELOCITY	JET VELOCITY
RXRN-AD81	5600 [2643]	0.36	39-49	920	920
	5800 [2737]	0.39	42-51	954	954
	6000 [2832]	0.42	44-54	1022	1022
	6200 [2926]	0.46	45-55	1056	1056
	6400 [3020]	0.50	46-55	1090	1090
	6600 [3115]	0.54	47-56	1124	1124

[] Designates Metric Conversions

CONCENTRIC DIFFUSER RXRN-AD86 SERIES 20 TON [70.3 kW] STEP DOWN

- All aluminum diffuser with aluminum return air eggcrate.
- Built-in anti-sweat gasket.
- Molded fiberglass supports.
- Built-in hanging supports.
- Diffuser box constructed of sheetmetal insulated with 1" [25.4 mm] 1.5 lbs. [.7 kg] duct liner.
- Double deflection diffuser with the blades secured by spring steel.

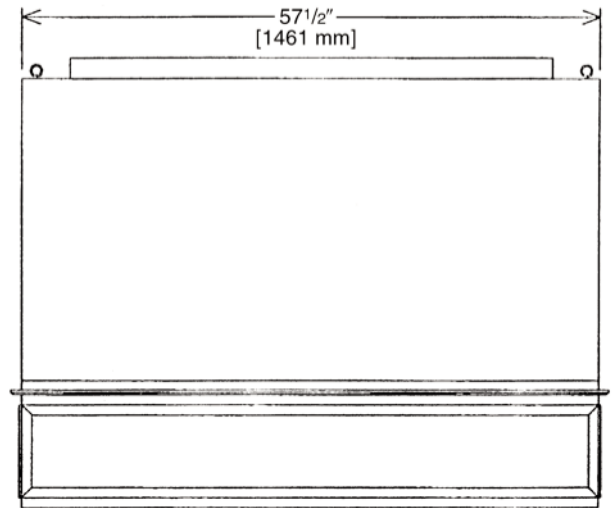
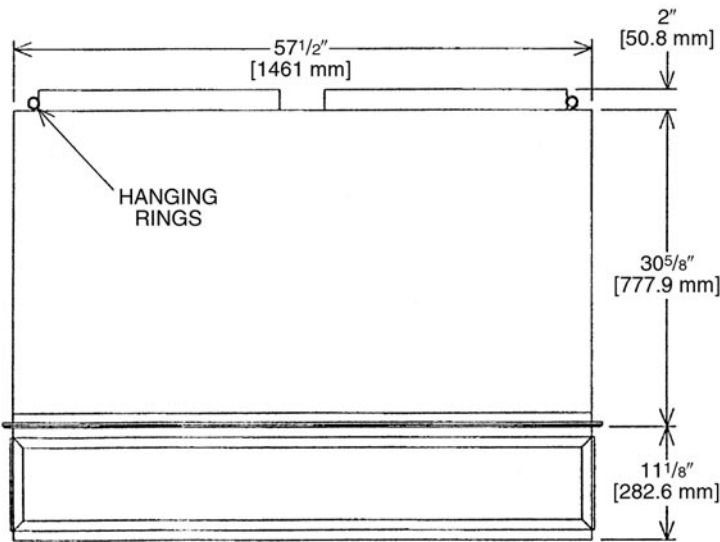
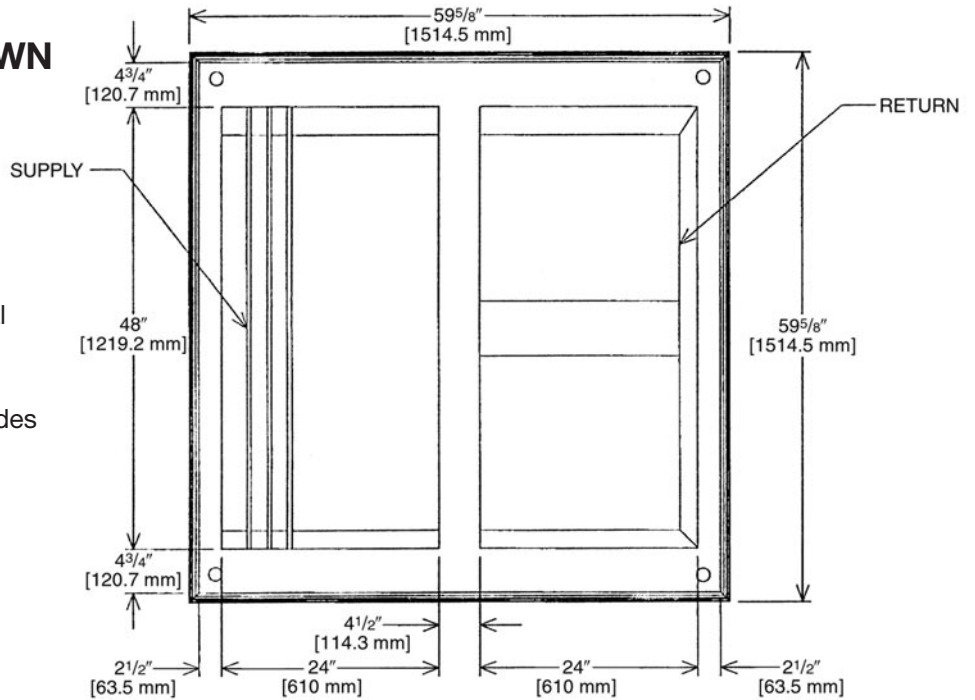

CONCENTRIC DIFFUSER SPECIFICATIONS

PART NUMBER	CFM [L/s]	STATIC PRESSURE	THROW FEET	NECK VELOCITY	JET VELOCITY
RXRN-AD86	7200 [3398]	0.39	33-38	827	827
	7400 [3492]	0.41	35-40	850	850
	7600 [3587]	0.43	36-41	873	873
	7800 [3681]	0.47	38-43	896	896
	8000 [3776]	0.50	39-44	918	918
	8200 [3870]	0.53	41-46	941	941
	8400 [3964]	0.56	43-49	964	964
	8600 [4059]	0.59	44-50	987	987
	8800 [4153]	0.63	47-55	1010	1010

[] Designates Metric Conversions

CONCENTRIC DIFFUSER RXRN-AD88 SERIES 25 TON [87.9 kW] STEP DOWN

- All aluminum diffuser with aluminum return air eggcrate.
- Built-in anti-sweat gasket.
- Molded fiberglass supports.
- Built-in hanging supports.
- Diffuser box constructed of sheetmetal insulated with 1" [25.4 mm] 1.5 lbs. [.7 kg] duct liner.
- Double deflection diffuser with the blades secured by spring steel.

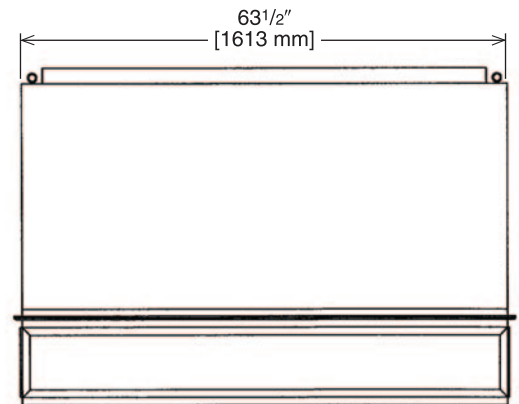
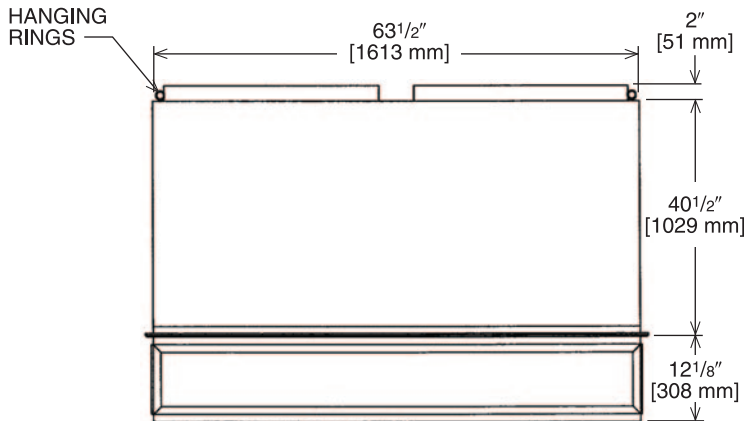
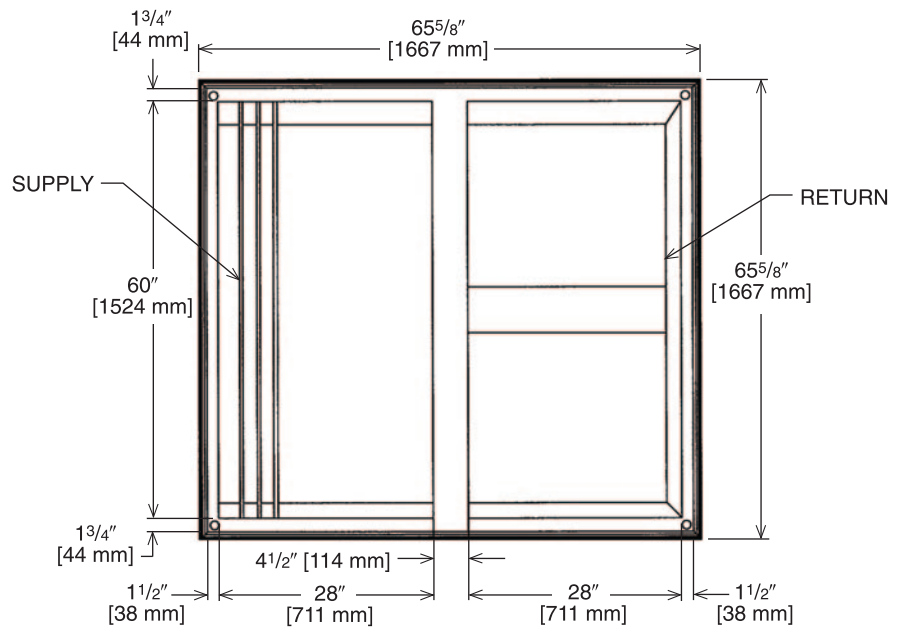

CONCENTRIC DIFFUSER SPECIFICATIONS

PART NUMBER	CFM [L/s]	STATIC PRESSURE	THROW FEET	NECK VELOCITY	JET VELOCITY
RXRN-AD88	10000 [4719]	0.51	46-54	907	907
	10500 [4955]	0.58	50-58	953	953
	11000 [5191]	0.65	53-61	998	998
	11500 [5427]	0.73	55-64	1043	1043
	12000 [5663]	0.82	58-67	1089	1089
	12500 [5898]	0.91	61-71	1134	1134
	13000 [6134]	1.00	64-74	1179	1179

[] Designates Metric Conversions

Guide Specifications – RLNL-H180 thru H300

You may copy this document directly into your building specification. This specification is written to comply with the 2004 version of the “master format” as published by the Construction Specification Institute. www.csinet.org.

ELECTRIC HEAT PACKAGED ROOFTOP

HVAC Guide Specifications

Size Range: 15 to 25 Nominal Tons

Section	Description
---------	-------------

23 06 80	Schedules for Decentralized HVAC Equipment
-----------------	---

23 06 80.13	Decentralized Unitary HVAC Equipment Schedule
-------------	---

23 06 80.13.A.	Rooftop unit schedule
----------------	-----------------------

1. Schedule is per the project specification requirements.

23 07 16	HVAC Equipment Insulation
-----------------	----------------------------------

23 07 16.13	Decentralized, Rooftop Units:
-------------	-------------------------------

1. Interior cabinet surfaces shall be insulated with a minimum 3/4-in. thick, minimum 1-1/2 lb density, flexible fiberglass insulation bonded with a phenolic binder, with aluminum foil facing on the air side.
2. Insulation and adhesive shall meet NFPA 90A requirements for flame spread and smoke generation.

23 09 13	Instrumentation and Control Devices for HVAC
-----------------	---

23 09 13.23	Sensors and Transmitters
-------------	--------------------------

23 09 13.23.A.	Thermostats
----------------	-------------

1. Thermostat must
 - a. have capability to energize 2 different stages of cooling, and 2 different stages of heating.
 - b. must include capability for occupancy scheduling.

23 09 23	Direct-digital Control system for HVAC
-----------------	---

23 09 23.13	Decentralized, Rooftop Units:
-------------	-------------------------------

23 09 23.13.A.	RTU-C controller
----------------	------------------

1. Shall be ASHRAE 62-2001 compliant.
2. Shall accept 18-32VAC input power.
3. Shall have an operating temperature range from -40°F (-40°C) to 158°F (70°C), 10% - 95% RH (non-condensing).
4. Controller shall accept the following inputs: space temperature, setpoint adjustment, outdoor air temperature, indoor air quality, outdoor air enthalpy, fire shutdown, return air enthalpy, fan status, remote time clock/door switch.
5. Shall accept a CO₂ sensor in the conditioned space, and be Demand Control Ventilation (DCV) ready.
6. Shall provide the following outputs: Economizer, fan, cooling stage 1, cooling stage 2, heat stage 1, heat stage 2, exhaust, occupied.
7. Unit shall provide surge protection for the controller through a circuit breaker.
8. Shall have a field installed communication card allowing the unit to be Internet capable, and communicate at a Baud rate of 19.2K or faster
9. Shall have an LED display independently showing the status of activity on the communication bus, and processor operation.
10. Shall have either a field installed BACnet® plug-in communication card which includes an EIA-485 protocol communication port, or a field installed LonWorks™ plug-in communications card.
11. Software upgrades will be accomplished by local download. Software upgrades through chip replacements are not allowed.
12. Shall be shock resistant in all planes to 5G peak, 11ms during operation, and 100G peak, 11ms during storage.
13. Shall be vibration resistant in all planes to 1.5G @ 20-300 Hz.
14. Shall support a bus length of 4000 ft max, 60 devices per 1000 ft section, and 1 RS-485 repeater per 1000 ft sections.

23 09 23.13.B.	Open protocol, direct digital controller:
----------------	---

1. Shall be ASHRAE 62-2001 compliant.
2. Shall accept 18-30VAC, 50-60Hz, and consumer 15VA or less power.
3. Shall have an operating temperature range from -40°F (-40°C) to 130°F (54°C), 10% - 90% RH (non-condensing).
4. Shall have either a field installed BACnet® plug-in communication card which includes an EIA-485 protocol communication port, or a field installed LonWorks™ plug-in communications card.
5. The BACnet® plug in communication card shall include built-in protocol for BACNET (MS/TP and PTP modes)
6. The LonWorks™ plug in communication card shall include the Echelon processor required for all Lon applications.
7. Shall allow access of up to 62 network variables (SNVT). Shall be compatible with all open controllers
8. Baud rate Controller shall be selectable through the EIA-485 protocol communication port.
9. Shall have an LED display independently showing the status of serial communication, running, errors, power, all digital outputs, and all analog inputs.
10. Shall accept the following inputs: space temperature, setpoint adjustment, outdoor air temperature, indoor air quality, outdoor air enthalpy, compressor lock-out, fire shutdown, enthalpy switch, and fan status/filter status/ humidity/ remote occupancy.
11. Shall provide the following outputs: economizer, fan, cooling stage 1, cooling stage 2, heat stage 1, heat stage 2, exhaust.
12. Software upgrades will be accomplished by either local or remote download. No software upgrades through chip replacements are allowed.

23 09 33 Electric and Electronic Control System for HVAC

23 09 33.13 Decentralized, Rooftop Units:

23 09 33.13.A. General:

1. Shall be complete with self-contained low-voltage control circuit protected by a resettable circuit breaker on the 24-v transformer side. Transformer shall have 100VA capabilities.
2. Shall utilize color-coded wiring.
3. Shall include a central control terminal board to conveniently and safely provide connection points for vital control functions such as: smoke detectors, phase monitor, economizer, thermostat, DDC control options, loss of charge, freeze sensor, high pressure switches.
4. Unit shall include a minimum of one 10-pin screw terminal connection board for connection of control wiring.

23 09 33.23.B. Safeties:

1. Compressor over-temperature, over current.
2. Loss of charge switch.
 - a. Units with 2 compressors shall have different colored wires for the circuit 1 and circuit 2 low and high pressure switches.
 - b. Loss of charge switch shall use different color wire than the high pressure switch. The purpose is to assist the installer and service technician to correctly wire and or troubleshoot the rooftop unit.
 - c. Loss of charge switch shall have a different sized connector than the high pressure switch. They shall physically prevent the cross-wiring of the safety switches between the high and low pressure side of the system.
3. High-pressure switch.
 - a. Units with 2 compressors shall have different colored wires for the circuit 1 and circuit 2 low and high pressure switches.
 - b. High pressure switch shall use different color wire than the low pressure switch. The purpose is to assist the installer and service person to correctly wire and or troubleshoot the rooftop unit.
 - c. High pressure switch shall have a different sized connector than the loss of charge switch. They shall physically prevent the cross-wiring of the safety switches between the high and low pressure side of the system.
4. Freeze protection sensor, evaporator coil.
5. Automatic reset, motor thermal overload protector.

23 09 93 Sequence of Operations for HVAC Controls

23 09 93.13 Decentralized, Rooftop Units:

23 09 93.13 INSERT SEQUENCE OF OPERATION

23 40 13 Panel Air Filters

23 40 13.13 Decentralized, Rooftop Units:

23 40 13.13.A. Standard filter section shall

1. Shall consist of factory-installed, low velocity, throwaway 2-in. thick fiberglass filters of commercially available sizes.
2. Filters shall be accessible through an access panel as described in the unit cabinet section of this specification (23 81 19.13.H).

23 81 19 Self-Contained Air Conditioners

23 81 19.13 Small-Capacity Self-Contained Air Conditioners

23 81 19.13.A. General

1. Outdoor, rooftop mounted, electrically controlled, heating and cooling unit utilizing a(n) hermetic scroll compressor(s) for cooling duty and heat pump for heating duty.
2. Factory assembled, single-piece heating and cooling rooftop unit. Contained within the unit enclosure shall be all factory wiring, piping, controls, and special features required prior to field start-up.
3. Unit shall use environmentally sound R-410a refrigerant.
4. Unit shall be installed in accordance with the manufacturer's instructions.
5. Unit must be selected and installed in compliance with local, state, and federal codes.

23 81 19.13.B. Quality Assurance

1. Unit meets ASHRAE 90.1-2004 minimum efficiency requirements.
2. 3 phase units are Energy Star qualified.
3. Unit shall be rated in accordance with AHRI Standards 210/240 and 340/360.
4. Unit shall be designed to conform to ASHRAE 15, 2001.
5. Unit shall be UL-tested and certified in accordance with ANSI Z21.47 Standards and UL-listed and certified under Canadian standards as a total package for safety requirements.
6. Insulation and adhesive shall meet NFPA 90A requirements for flame spread and smoke generation.
7. Unit casing shall be capable of withstanding 500-hour salt spray exposure per ASTM B117 (scribed specimen).
8. Unit casing shall be capable of withstanding Federal Test Method Standard No. 141 (Method 6061) 5000-hour salt spray.
9. Unit shall be designed in accordance with ISO 9001:2000, and shall be manufactured in a facility registered by ISO 9001:2000.
10. Roof curb shall be designed to conform to NRCA Standards.
11. Unit shall be subjected to a completely automated run test on the assembly line. The data for each unit will be stored at the factory, and must be available upon request.
12. Unit shall be designed in accordance with UL Standard 1995, including tested to withstand rain.
13. Unit shall be constructed to prevent intrusion of snow and tested to prevent snow intrusion into the control box up to 40 mph.

23 81 19.13.C. Delivery, Storage, and Handling

1. Unit shall be stored and handled per manufacturer's recommendations.
2. Lifted by crane requires either shipping top panel or spreader bars.
3. Unit shall only be stored or positioned in the upright position.

23 81 19.13.E. Project Conditions

1. As specified in the contract.

23 81 19.13.F. Operating Characteristics

1. Unit shall be capable of starting and running at 115°F (46°C) ambient outdoor temperature, meeting maximum load criteria of AHRI Standard 210/240 or 340/360 at ± 10% voltage.
2. Compressor with standard controls shall be capable of operation from 40°F (4°C) , ambient outdoor temperatures. Accessory low ambient kit is necessary if mechanically cooling at ambient temperatures below 40°F (4°C).
3. Unit shall discharge supply air vertically or horizontally as shown on contract drawings.
4. Unit shall be factory configured for vertical supply & return configurations.
5. Unit shall be field convertible from vertical to horizontal configuration.

23 81 19.13.G. Electrical Requirements

1. Main power supply voltage, phase, and frequency must match those required by the manufacturer.

23 81 19.13.H. Unit Cabinet

1. Unit cabinet shall be constructed of galvanized steel, and shall be bonderized and coated with a baked enamel finish on all externally exposed surfaces.
2. Unit cabinet exterior paint shall be: film thickness, (dry) 0.003 inches minimum, gloss (per ASTM D523, 60°F): 60, Hardness: H-2H Pencil hardness.
3. Evaporator fan compartment interior cabinet insulation shall conform to AHRI Standards 210/240 or 340/360 minimum exterior sweat criteria. Interior surfaces shall be insulated with a minimum 3/4-in. thick, 1 lb density, flexible fiberglass insulation, aluminum foil-faced on the air side.
4. Base of unit shall have locations for thru-the-base electrical connections (factory installed or field installed), standard.
5. Base Rail
 - a. Unit shall have base rails on all sides.
 - b. Holes shall be provided in the base rails for rigging shackles to facilitate maneuvering and overhead rigging.
 - c. Holes shall be provided in the base rail for moving the rooftop by fork truck.
 - d. Base rail shall be a minimum of 14 gauge thickness.
6. Condensate pan and connections:
 - a. Shall be a sloped condensate drain pan made of a non-corrosive material.
 - b. Shall comply with ASHRAE Standard 62.
 - c. Shall use a 1" -11 1/2 NPT drain connection, through the side of the drain pan. Connection shall be made per manufacturer's recommendations.
7. Electrical Connections
 - a. All unit power wiring shall enter unit cabinet at a single, factory-prepared, knockout location.
 - b. Thru-the-base capability
 - (1.) Standard unit shall have a thru-the-base electrical location(s) using a raised, embossed portion of the unit basepan.
 - (2.) No basepan penetration, other than those authorized by the manufacturer, is permitted.
8. Component access panels (standard)
 - a. Cabinet panels shall be easily removable for servicing.
 - b. Stainless steel metal hinges are standard on all doors.
 - c. Panels covering control box, indoor fan, indoor fan motor, and electric or gas heater components (where applicable), shall have 1/4 turn latches.

23 81 19.13.J. Coils

1. Standard Aluminum/Copper Coils: on all models.
 - a. Standard evaporator and condenser coils shall have aluminum lanced plate fins mechanically bonded to seamless internally grooved copper tubes with all joints brazed.
 - b. Evaporator and Condenser coils shall be leak tested to 150 psig, pressure tested to 550 psig, and qualified to UL 1995 burst test at 2,200 psig.

23 81 19.13.K. Refrigerant Components

1. Refrigerant circuit shall include the following control, safety, and maintenance features:
 - a. Thermal Expansion Valve (TXV) with orifice type distributor
 - b. Refrigerant filter drier.
 - c. External service gauge connections to unit suction and discharge lines.
 - d. Pressure gauge access through an access port in the front and rear panel of the unit.
2. Compressors
 - a. Unit shall use one fully hermetic, scroll compressor for each independent refrigeration circuit.
 - b. Compressor motors shall be cooled by refrigerant gas passing through motor windings.
 - c. Compressors shall be internally protected from high discharge temperature conditions. Advanced Scroll Temperature Protection on 240-300 sizes.

- d. Compressors shall be protected from an over-temperature and over-ampereage conditions by an internal, motor overload device.
- e. Compressor shall be factory mounted on rubber grommets.
- f. Compressor motors shall have internal line break thermal, current overload and high pressure differential protection.
- g. Crankcase heaters shall not be required for normal operating range.

23 81 19.13.L. Filter Section

- 1. Filters access is specified in the unit cabinet section of this specification.
- 2. Filters shall be held in place by a sliding filter tray, facilitating easy removal and installation.
- 3. Shall consist of factory-installed, low velocity, throw-away 2-in. thick fiberglass filters.
- 4. Filters shall be standard, commercially available sizes.
- 5. Filter face velocity shall not exceed 365 fpm at nominal airflows.

23 81 19.13.M. Evaporator Fan and Motor

- 1. Evaporator fan motor:
 - a. Shall have permanently lubricated bearings.
 - b. Shall have inherent automatic-reset thermal overload protection or circuit breaker.
 - c. Shall have a maximum continuous bhp rating for continuous duty operation; no safety factors above that rating shall be required.
- 2. Belt-driven Evaporator Fan:
 - a. Belt drive shall include an adjustable-pitch motor pulley.
 - b. Shall use sealed, permanently lubricated ball-bearing type.
 - c. Blower fan shall be double-inlet type with forward-curved blades.
 - d. Shall be constructed from steel with a corrosion resistant finish and dynamically balanced.

23 81 19.13.N. Condenser Fans and Motors

- 1. Condenser fan motors:
 - a. Shall be a totally enclosed motor.
 - b. Shall use permanently lubricated bearings.
 - c. Shall have inherent thermal overload protection with an automatic reset feature.
 - d. Shall use a shaft-down design. Shaft-up designs including those with "rain-slinger devices" shall not be allowed.
- 2. Condenser Fans:
 - a. Shall be a direct-driven propeller type fan.
 - b. Shall have aluminum blades riveted to corrosion-resistant steel spiders and shall be dynamically balanced.

23 81 19.13.O. Special Features, Options and Accessories

- 1. Integrated Economizers:
 - a. Integrated, gear-driven parallel modulating blade design type capable of simultaneous economizer and compressor operation.
 - b. Independent modules for vertical or horizontal return configurations shall be available. Vertical return modules shall be available as a factory installed option.
 - c. Damper blades shall be galvanized steel with metal gears. Plastic or composite blades on intake or return shall not be acceptable.
 - d. Shall include all hardware and controls to provide free cooling with outdoor air when temperature and/or humidity are below setpoints.
 - e. Shall be equipped with gear driven dampers for both the outdoor ventilation air and the return air for positive air stream control.
 - f. Shall be capable of introducing up to 100% outdoor air.
 - g. Shall be equipped with a barometric relief damper capable of relieving up to 100% return air.
 - h. Shall be designed to close damper(s) during loss-of-power situations with spring return built into motor.
 - i. An outdoor single enthalpy sensor shall be provided as standard. Outdoor air sensor setpoint shall be adjustable and shall range from the enthalpy equivalent of 63°F @ 50% rh to 73°F @ 50% rh. Additional sensor options shall be available as accessories.
 - j. The economizer controller shall also provide control of an accessory power exhaust unit function. Factory set at 70%, with a range of 0% to 100%.
 - k. The economizer shall maintain minimum airflow into the building during occupied period and provide design ventilation rate for full occupancy. A remote potentiometer may be used to override the damper setpoint.
 - l. Dampers shall be completely closed when the unit is in the unoccupied mode.
 - m. Economizer controller shall accept a 2-10Vdc CO₂ sensor input for IAQ/DCV control. In this mode, dampers shall modulate the outdoor-air damper to provide ventilation based on the sensor input.
 - n. Compressor lockout sensor on the unit controller is factory set at 35°F and is adjustable from 30°F (-1°C) to 50°F (10°C) and resets the cooling lockout at 5°F (+2.7°C) above the set point.
 - o. Actuator shall be direct coupled to economizer gear. No linkage arms or control rods shall be acceptable.
 - p. Economizer controller shall provide indications when in free cooling mode, in the DCV mode, or the exhaust fan contact is closed.
 - q. Economizer wire harness will have provision for smoke detector.

2. Two-Position Motorized Damper
 - a. Damper shall be a Two-Position Motorized Damper. Damper travel shall be from the full closed position to the field adjustable %-open setpoint.
 - b. Damper shall include adjustable damper travel from 25% to 100% (full open).
 - c. Damper shall include single or dual blade, gear driven dampers and actuator motor.
 - d. Actuator shall be direct coupled to damper gear. No linkage arms or control rods shall be acceptable.
 - e. Damper will admit up to 100% outdoor air for applicable rooftop units.
 - f. Damper shall close upon indoor (evaporator) fan shutoff and/or loss of power.
 - g. The damper actuator shall plug into the rooftop unit's wiring harness plug. No hard wiring shall be required.
 - h. Outside air hood shall include aluminum water entrainment filter
3. Manual damper
 - a. Manual damper package shall consist of damper, air inlet screen, and rain hood which can be preset to admit up to 50% outdoor air for year round ventilation.
4. Head Pressure Control Package
 - a. Controller shall control coil head pressure by condenser-fan cycling.
5. Condenser Coil Hail Guard Assembly
 - a. Shall protect against damage from hail.
 - b. Shall be louvered design.
6. Convenience Outlet:
 - a. Non-Powered convenience outlet.
 - (1.) Outlet shall be powered from a separate 115-120v power source.
 - (2.) A transformer shall not be included.
 - (3.) Outlet shall be factory-installed and internally mounted with easily accessible 115-v female receptacle.
 - (4.) Outlet shall include 15 amp GFI receptacles.
 - (5.) Outlet shall be accessible from outside the unit.
7. Fan/Filter Status Switch:
 - a. Switch shall provide status of indoor evaporator fan (ON/OFF) or filter (CLEAN/DIRTY).
 - b. Status shall be displayed either over communication bus (when used with direct digital controls) or through the controller LCD display inside the unit control box.
8. Propeller Power Exhaust:
 - a. Power exhaust shall be used in conjunction with an integrated economizer.
 - b. Independent modules for vertical or horizontal return configurations shall be available.
 - c. Horizontal power exhaust is shall be mounted in return ductwork.
 - d. Power exhaust shall be controlled by economizer controller operation. Exhaust fans shall be energized when dampers open past the 0-100% adjustable setpoint on the economizer control.
9. Roof Curbs (Vertical):
 - a. Full perimeter roof curb with exhaust capability providing separate air streams for energy recovery from the exhaust air without supply air contamination.
 - b. Formed galvanized steel with wood nailer strip and shall be capable of supporting entire unit weight.
 - c. Permits installation and securing of ductwork to curb prior to mounting unit on the curb.
10. High-Static Indoor Fan Motor(s) and Drive(s):
 - a. High-static motor(s) and drive(s) shall be factory-installed to provide additional performance range.
11. Outdoor Air Enthalpy Sensor:
 - a. The outdoor air enthalpy sensor shall be used to provide single enthalpy control. When used in conjunction with a return air enthalpy sensor, the unit will provide differential enthalpy control. The sensor allows the unit to determine if outside air is suitable for free cooling.
13. Return Air Enthalpy Sensor:
 - a. The return air enthalpy sensor shall be used in conjunction with an outdoor air enthalpy sensor to provide differential enthalpy control.
14. Indoor Air Quality (CO₂) Sensor:
 - a. Shall be able to provide demand ventilation indoor air quality (IAQ) control.
 - b. The IAQ sensor shall be available in wall mount with LED display. The setpoint shall have adjustment capability.
15. Smoke detectors:
 - a. Shall be a Four-Wire Controller and Detector.
 - b. Shall be environmental compensated with differential sensing for reliable, stable, and drift-free sensitivity.
 - c. Shall use magnet-activated test/reset sensor switches.
 - d. Shall have a recessed momentary switch for testing and resetting the detector.
 - e. Controller shall include:

- (1.) One set of normally open alarm initiation contacts for connection to an initiating device circuit on a fire alarm control panel.
- (2.) Two Form-C auxiliary alarm relays for interface with rooftop unit or other equipment.
- (3.) One Form-C supervision (trouble) relay to control the operation of the Trouble LED on a remote test/reset station.
- (4.) Capable of direct connection to two individual detector modules.
- (5.) Can be wired to up to 14 other duct smoke detectors for multiple fan shutdown applications.

16. Electric Heat:

a. Heating Section

- (1.) Heater element open coil resistance wire, nickel-chrome alloy, strung through ceramic insulators mounted on metal frame. Coil ends are staked and welded to terminal screw slots.
- (2.) Heater assemblies are provided with integral fusing for protection of internal heater circuits not exceeding 48 amps each. Auto reset thermo limit controls, magnetic heater contactors (24 v coil) and terminal block all mounted in electric heater control box (minimum 18 ga galvanized steel) attached to end of heater assembly.

26 29 23.12 Adjustable Frequency Drive

1. Unit shall be supplied with an electronic variable frequency drive for the supply air fan.
2. Drive shall be factory installed in an enclosed cabinet.
3. Drive shall meet UL Standard 95-5V.
4. The completed unit assembly shall be UL listed.
5. Drives are to be accessible through a tooled access hinged door assembly.
6. The unit manufacturer shall install all power and control wiring.
7. The supply air fan drive output shall be controlled by the factory installed main unit control system and drive status and operating speed shall be monitored and displayed at the main unit control panel.
8. Drive shall be programmed and factory run tested in the unit.

BEFORE PURCHASING THIS APPLIANCE, READ IMPORTANT ENERGY COST AND EFFICIENCY INFORMATION AVAILABLE FROM YOUR RETAILER.

GENERAL TERMS OF LIMITED WARRANTY*

Friedrich® will furnish a replacement for any part of this product which fails in normal use and service within the applicable periods stated, in accordance with the terms of the limited warranty.

***For complete details of the Limited and Conditional Warranties, including applicable terms and conditions, contact your local contractor or the Manufacturer for a copy of the product warranty certificate.**

Compressor	
3 Phase, Commercial Applications.....	Five (5) Years
Parts	
3 Phase, Commercial Applications	One (1) Year



FRIEDRICH

1 8 8 3

Before proceeding with installation, refer to installation instructions packaged with each model, as well as complying with all Federal, State, Provincial, and Local codes, regulations, and practices.

© 2023 Rheem Manufacturing Company. Friedrich trademarks owned by Rheem Manufacturing Company.

In keeping with its policy of continuous progress and product improvement, Friedrich reserves the right to make changes without notice.

Friedrich • 5600 Old Greenwood Road
Fort Smith, Arkansas 72908 • www.friedrich.com

Friedrich • 125 Edgeware Road, Unit 1
Brampton, Ontario • L6Y 0P5