



FRIEDRICH

1 8 8 3

**Commercial Resolute™ Line
Packaged Gas Electric Unit**



RGEH Commercial Resolute™ Line

Nominal Size 27.5 [96.7 kW]

Standard Variable Frequency Drive and Variable Air Volume

ASHRAE 90.1-2019 Compliant Models



TABLE OF CONTENTS

Unit Features & Benefits	3-10
Model Number Identification	11
Options	12-13
Selection Procedure	14
General Data.....	15-19
General Data Notes	20
Gross Systems Performance Data	21
Heating Performance Data	22
Indoor Airflow Performance	23-26
Electrical Data.....	27-31
Dimensional Data	32-35
Accessories	36-47
Mechanical Specifications	48-54
Limited Warranty	55



RGEH STANDARD FEATURES INCLUDE:

- Factory charged with R-410A HFC refrigerant
- Wired and run tested
- Scroll compressors with internal line break overload and high pressure protection
- One single-stage and one two-stage compressor to enable 5 stages of cooling
- Convertible airflow—vertical downflow or horizontal side flow
- Forkable base rails for easy handling and lifting
- Cooling operation up to 125°F ambient
- MicroChannel condenser coil and Tube and Fin evaporator coil
- ClearControl™ (DDC) and Phase Monitor
- Single and Multi-Zone Variable Air Volume (VAV) Capable
- Two-piece control door
- 1/4 turn fasteners on filter access door
- Color-coded and labeled wiring
- TXV refrigerant metering system
- Solid-core liquid line filter drier
- High pressure and low pressure/loss of charge protection with built in Smart Logic
- Insulation encapsulated throughout entire unit
- High performance belt drive motor with variable pitch pulleys and quick adjust belt system
- Variable Frequency Drive (VFD) blower is standard on all models

FACTORY INSTALLED OPTIONS:

- Louvered panels
- Hinged access doors
- Low ambient/freeze stat
- Non-powered convenience outlet
- Economizers (Title 24 and ASHRAE 90.1 2019 Compliant)

- Supply and return smoke detector
- Return smoke detector
- ClearControl™ Direct Digital Control (DDC)
- Comfort Alert/Phase monitor
- Disconnect Switch

FIELD INSTALLED ACCESSORY EQUIPMENT:

Accessory	Model Number	Factory Installation Available?
Economizer w/Single Enthalpy (Downflow)	AXRD-01RMDCM3	Yes
Economizer w/Single Enthalpy (Horizontal)	AXRD-01RMHCM3	No
Dual Enthalpy Kit	RXXR-AV01	No
Carbon Dioxide Sensor (Wall Mount)	RXXR-AR02	No
Power Exhaust (230V)	RXXR-BGF05C	No
Power Exhaust (460V)	RXXR-BGF05D	No
Power Exhaust (575V)	RXXR-BGF05Y	No
Manual Fresh Air Damper	AXRF-KFA1	No
2-Position Motorized Kit for Fresh Air Damper	RXRF-AW03	No
Modulating Motor Kit for AXRF-KFA1	RXRF-AW05	No
Roofcurb, 14"	RXKG-CBH14	No
Concentric Diffuser (Step-Down, 18" x 36")	RXRN-AD81	No
Concentric Diffuser (Step-Down, 24" x 48")	RXRN-AD86	No
Concentric Diffuser (Step-Down, 28" x 60")	RXRN-AD88	No
Concentric Diffuser (Flush, 18" x 36")	RXRN-AD80	No
Downflow Transition (Rect. To Rect., 18" x 36")	RXMC-CJ07	No
Downflow Transition (Rect. To Rect., 24" x 48")	RXMC-CK08	No

Accessory	Model Number	Factory Installation Available?
Downflow Transition (Rect. To Rect., 28" x 60")	RXMC-CL09	No
BACnet Communication Card	RXXR-AY01	No
LonWorks Communication Card	RXXR-AY02	No
Room Humidity Sensor	RHC-ZNS4	No
Room Temperature and Relative Humidity Sensor	RHC-ZNS5	No
Low-Ambient Control Kit DDC (1 Per Compressor)	RXRZ-C02	No
Freeze Stat Kit	RXXR-AM05	Yes
Unwired Convenience Outlet	RXXR-AN01	Yes
Hail Guard Louvers	AXRX-AAD01L	Yes
Return Smoke Detector (Downflow/Vertical)	RXXR-BSH1	Yes
Return Smoke Detector (Horizontal)	RXXR-BSH2	Yes
Return/Supply Smoke Detector (Downflow/Vertical)	RXXR-BSH3	Yes
Return/Supply Smoke Detector (Horizontal)	RXXR-BSH4	Yes
MERV 8 Filter	RXMF-M08A22520	Yes
MERV 13 Filter	RXMF-M13A22520	Yes

Proof

Current inventory _____

Date: _____ Form No. _____ Proof No. _____

DC Job No. _____ Rev.# _____ Model No. _____ No. of Pages _____

**Please indicate on this proof if any corrections are to be made.
After you have read this proof carefully, please sign on the appropriate line.**

OK AS IS, NO CHANGES

Initials _____

Date _____

CHANGES AS INDICATED (An additional proof will be submitted)

Initials _____

Date _____

NO NEW PROOF REQUIRED

Print Quantity _____ 30 Days 60 Days 90 Days

PRINT ON DEMAND (description) _____

FINISHING: Saddle Stitch Corner Stitch Perfect Bind UV Coat None

THIS IS:

New Revision All New?

ACCOUNTING CODE _____

PROJECT # _____

If All New, does this replace another sheet? NO IF YES Form # _____

CHECK ALL THAT WILL BE AFFECTED BELOW:

- RUUD WEATHERKING THERMALZONE SURECOMFORT MAINLINE ELITE MAINLINE PERFORMANCE FUJITSU
- RHEEM-WEATHERKING CLIMATEMASTER RUSSELL BY RHEEM RHEEM SELECT RUUD CHOICE DURASTAR FRIEDRICH
- Sales Fact Sheet Submittal Sheet

Product Description _____

PLEASE CHECK WHICH TAG SHOULD BE USED ON BRAND ZONE IF APPLICABLE, IF NO TAG SHOULD BE USED, PLEASE CHECK NONE.



NONE

NOTES:

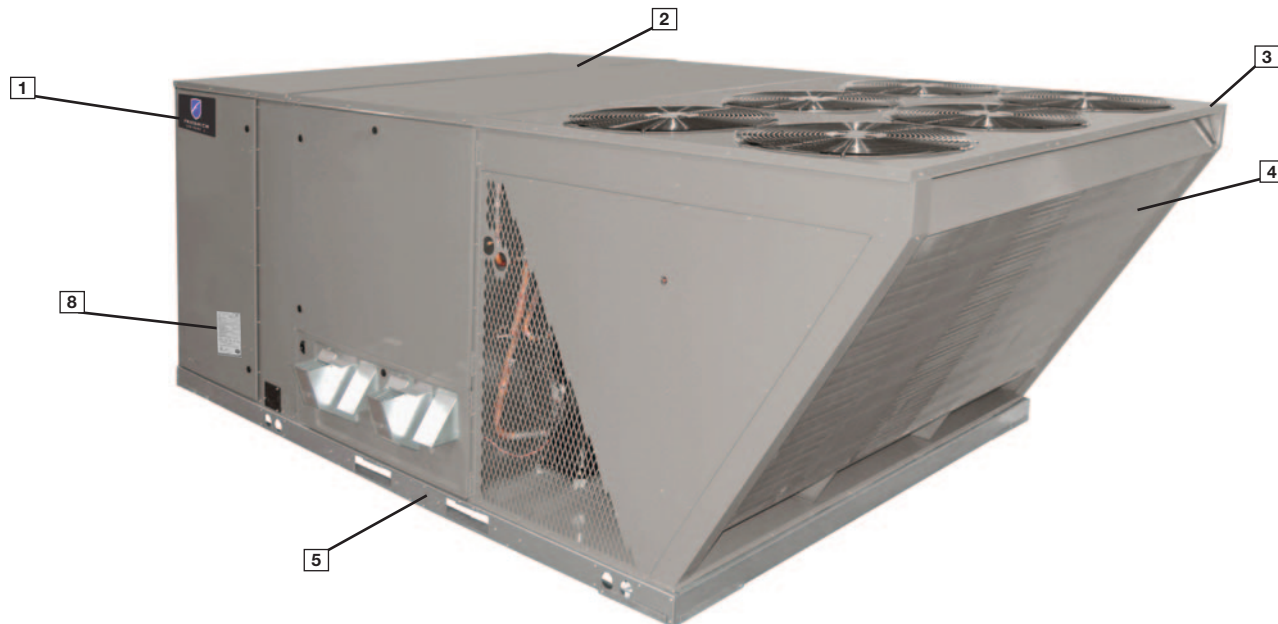

Cabinet and Foundation

Resolute™ Packaged-equipment is design from the ground up with the latest features and benefits required to compete in today's market. The clean design stands alone in the industry and is a testament to the quality, reliability, ease of installation and serviceability that goes into each unit. Outwardly, the Friedrich® label (1) identifies the brand to the customer.

The sheet metal cabinet (2) uses nothing less than 20-gauge material for structural components with an underlying coat of G90. To ensure the leak-proof integrity of these units, the design utilizes a top with a 1/8" drip lip (3), gasket-protected panels and screws. The slanted outdoor coil protects the coil from hail damage (4). Every Friedrich packaged unit uses the toughest finish in the industry, using electro deposition baked-on enamel tested to withstand a rigorous 1000-hour salt spray test, per ASTM B117.

Base Pan and Foundation

Anything built to last must start with the right foundation. In this case, the foundation is a 14-gauge, commercial-grade, full-perimeter base rails (5), which integrate fork slots and rigging holes to save set-up time on the job site. The basepan is stamped, which forms a 1-1/8" flange around the supply and return opening and has eliminated the worry of water entering the conditioned space (6).

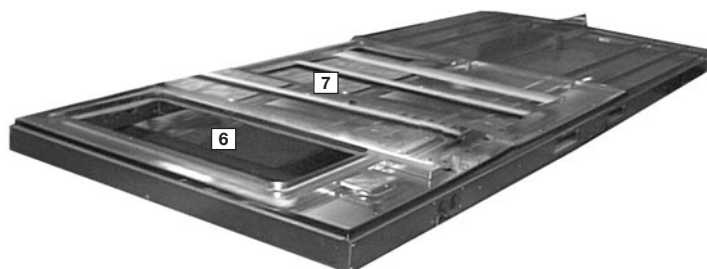

Drain Pan

The drainpan (7) is made of plastic that resists the growth of harmful bacteria and is sloped for the latest IAQ benefits. Furthermore, the drainpan slides out for easy cleaning. The insulation has been placed on the underside of the basepan, removing areas that would allow for potential moisture accumulation, which can facilitate growth of harmful bacteria. All insulation is secured with both adhesive and mechanical fasteners, and all edges are hidden.

Test Standards

During development, each unit was tested to U.L. 1995, ANSI 21.47, AHRI 340/360 and other Friedrich-required reliability tests. Friedrich adheres to stringent ISO 9001:2015 quality procedures, and each unit bears the U.L. and AHRI certification labels located on the unit nameplate (8). Contractors can rest assured that when a Friedrich packaged unit arrives at the job, it is ready to go with a factory charge and quality checks.

Easy Access

Access all major compartments from the front of the unit, including the filter and electrical compartment, blower compartment, heating section, and outdoor section. Each panel is permanently embossed with the compartment name (control/filter access, blower access, and furnace access).

Electrical and filter compartment access is through a large, toolless, hinged-access panel with 1/4 turn latches. On the outside of the panel is the unit nameplate, which contains the model and serial number, electrical data, and other important unit information.

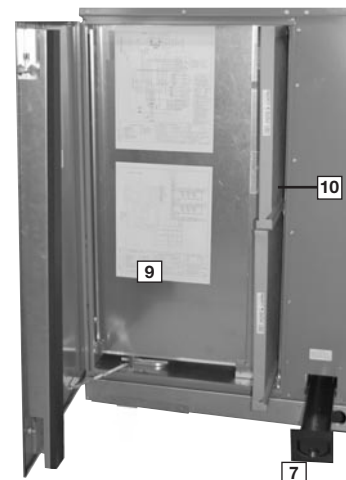

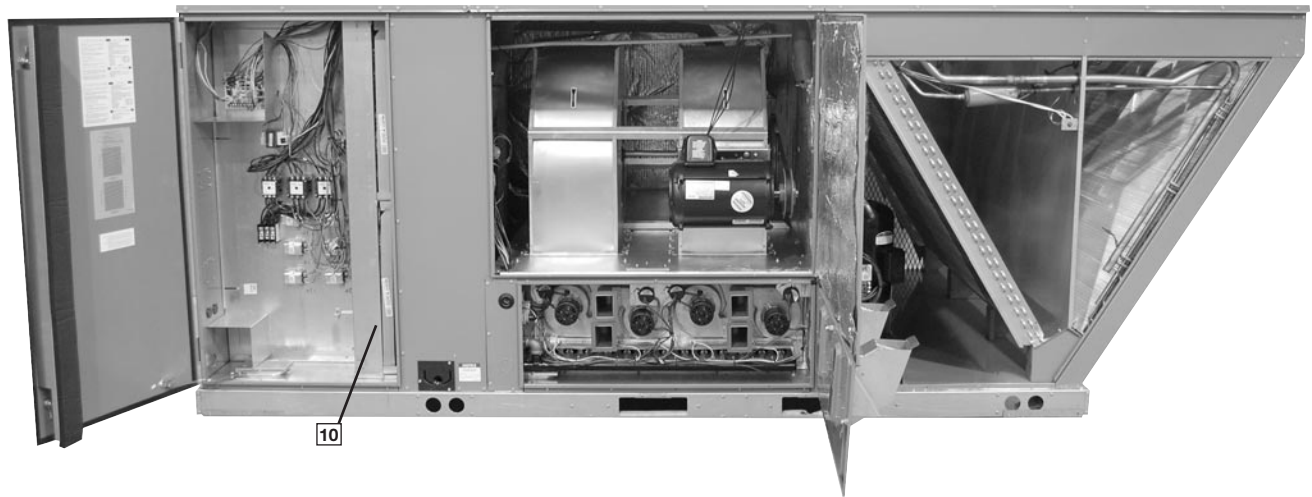

Charging Charts, Wiring Diagrams, & Labels

The unit charging chart is located on the inside of the electrical and filter compartment door. Electrical wiring diagrams are found on the control box cover, which allows contractors to move them to more readable locations. To the right of the control box, the model and serial number can be found. Having this information on the inside will assure model identification for the life of the product. The production line quality test assurance label is also placed in this location (9).

Filter Rack

The two-inch throwaway filters (10) are easily removed on a slide-out tracked system for easy replacement.



Blower Assembly

The blower compartment is to the right of the control box and can be accessed by 1/4 turn latches. To allow easy maintenance of the blower assembly, the entire assembly easily slides out by removing four #10 screws from the blower assembly. The adjustable motor pulley (11) can easily be adjusted by loosening the bolts on either side of the motor mount. Removing the bolts allows for easy removal of the blower pulley by pushing the blower assembly up to loosen the belt. Once the belt is removed, the motor sheave can be adjusted to the desired number of turns, ranging from 1 to 6 turns open.

Where the demands for the job require high static, Friedrich® has high-static drives available that deliver nominal airflow up to 2" of static. By referring to the airflow performance tables listed in the installation instruction, proper static pressure and CFM requirements can be dialed in. The scroll housing (12) and blower scroll provide quiet and efficient airflow. The blower

sheave is secured by an "H" bushing which firmly secures the pulley to the blower shaft for years of trouble-free operation. The "H" bushing allows for easy removal of the blower pulley from the shaft, creating burrs that make blower-pulley removal difficult.



High and Low Pressure Switches & Freeze Stat

The low-pressure switches and high-pressure switches are mounted on the appropriate refrigerant lines in the condenser section. The high-pressure switch will shut off the compressors if pressures exceeding 610 PSIG are detected as may occur if the outdoor fan motor fails. The low-pressure switches shut off the compressors if low pressure is detected due to loss of refrigerant charge. Each factory-installed option is brazed into the appropriate high or low side and wired appropriately. Use of polarized plugs allow for easy field inspection and repair.

Thermostatic Expansion Valve (TXV)

Inside the blower compartment the interlaced evaporator can also be viewed. The evaporator uses fin technology for maximum heat transfer. The TXV (13) metering device assures even distribution of refrigerant throughout the evaporator.



Control Box

Inside the control box (14), each electrical component is clearly identified with a label that matches the component to the wire diagram for ease of trouble shooting. Most of the wiring is numbered on each end of the termination and color-coded to match the wiring diagram. The integrated furnace control, used to control furnace operation, incorporated a flashing LED troubleshooting device. Flash codes are clearly outlined on the unit wiring diagram. The control transformer has a low voltage circuit breaker that trips if a low voltage electrical short occurs. There is also a compressor contactor for each compressor.



Convenience Outlet, Disconnect & Circuit Breaker

For added convenience in the field, a factory-installed disconnect switch and a field-installed convenience outlet (15) are available. Low and High voltage can enter either from the side or through the base. Low-voltage connections are made through the low-voltage terminal strip. For ease of access, the U.L.-required low voltage barrier can be temporarily removed for low-voltage termination and then reinstalled. The high-voltage connection is terminated at the high-voltage terminal blow. The suggested mounting for the field-installed disconnect is on the exterior side of the electrical control box.



The high (16) and low (17) external gauge ports are located in the outdoor section. With gauge ports mounted externally, an accurate diagnostic of system operation can be performed quickly and without removing exterior panels.



ClearControl™

As part of the ClearControl™ system (18) which allows real time monitoring and communication between rooftop units, the RGEH Packaged AC Unit has a Rooftop Unit Controller (RTU-C) factory mounted and wired in the control panel. The RTU-C is a solid-state microprocessor-based control board that provides flexible



control and extensive diagnostics for all unit functions. The RTU-C through proportional/integral control algorithms perform specific unit functions that govern unit operation in response to: zone conditions, system temperatures, system pressures, ambient conditions, and electrical inputs. The RTU-C features a 16 x 2 character LCD display and a five-button keypad for local configuration and direct diagnosis of the system. Features include a clogged filter switch (CFS), fan proving switch (FPS), return air temperature sensor (RAT), discharge air temperature sensor (DAT), and outdoor air temperature sensor (OAT). Freeze sensors (FS) are used in place of freezestats to allow measurement of refrigerant suction line temperatures.

The RGEH with the RTU-C is specifically designed to be applied in four distinct applications:

- 1. BACnet Communication** — The RGEH is compatible with a third party building management system that supports the BACnet Application Specific Controller device profile, with the use of a field installed BACnet Communication Module. The BACnet Communication Module plugs into the unit RTU-C controller and allows communication between ClearControl™ and the BACnet MSTP or IP network. A zone sensor, a BACnet network zone sensor, a BACnet thermostat or DDC controller may be used to send the zone thermostat or thermostat demands to the RTU-C. The BACnet Communication Module is compatible with MSTP EIA-485 daisy chain networks communicating at 38.4 bps. It is compatible with twisted pair, shielded cables.
- 2. LonWorks Communication** — The RGEH is compatible with a third party building management system that supports the LonMark Space Comfort Controller (SCC) functional profile or LonMark Discharge Air Controller (DAC) functional profile. This is accomplished with a field installed LonMark communication module. The LonMark Communication Module plugs onto the RTU-C controller and allows communication between ClearControl™ and a LonWorks network. A zone sensor, a LonTalk network zone sensor, or a LonTalk thermostat or DDC controller may be used to send the zone temperature or thermostat demands to the RTU-C. The LonMark Communication Module utilizes an FTT-10A free topology transceiver communicating at 78.8 kbps. It is compatible with Echelon qualified, twisted pair cable, Belden 8471, or NEMA Level 4 cables. The module can communicate up to 1640 feet with no repeater. The LonWorks limit of 64 nodes per segment applies to this device.
- 3. 24V Thermostat Compatibility** — The RGEH is compatible with a programmable 24 volt thermostat. Connections are made via conventional thermostat screw terminals. Extensive unit status and diagnostics are displayed on the LCD screen of the RTU-C.
- 4. Zone Sensor Compatibility** — The RGEH is compatible with a zone sensor and a mechanical or solid state time clock connected to the RTU-C. Extensive unit status and diagnostics are displayed on the LCD screen of the RTU-C.

ComfortAlert®

A factory or field installed Comfort Alert® module is available for power phase-monitoring protection and additional compressor diagnostics. The alarms can be displayed on the RTU-C display, through the (BAS) network, or connected to the “L-Terminal” of a thermostat for notification. Wiring throughout the unit is neatly bundled and routed. Where wire harnesses go through the condenser bulkhead or blower deck, a molded wire harness assembly (19) provides an air-tight and water-tight seal, and provides strain relief. Care is also taken to tuck raw edges of insulation behind sheet metal to improve indoor air quality.



The furnace compartment contains the latest furnace technology on the market. The draft inducers (20) draw the flame from the Friedrich® exclusive in-shot burners (21) into the aluminized tubular heat exchanger (22) for clean, efficient gas heat. Stainless steel heat exchangers can be factory installed for those applications that have high fresh-air requirements, or applications in corrosive environments. Each furnace is equipped with a two-stage gas valve (23), which provides two stages of gas heat input. The first stage operates at 50% of the second stage (full fire). 81% steady state efficiency is maintained on both first and second stage by staging the multiple inducers to optimize the combustion airflow and maintain a near stoichiometric burn at each stage.

The direct spark igniter (24) assures reliable ignition in the most adverse conditions. This is coupled with remote flame sensor (25) to assure that the flame has carried across the entire length of the burner assembly. Gas supply can be routed from the side or up through the base.

Each furnace has the following safety devices to assure consistent and reliable operation after ignition:

- Pressures switches (26) to assure adequate combustion airflow before ignition.
- Rollout switches (27) to assure no obstruction or cracks in the heat exchanger.
- A limit device that protects the furnace from over-temperature problems.

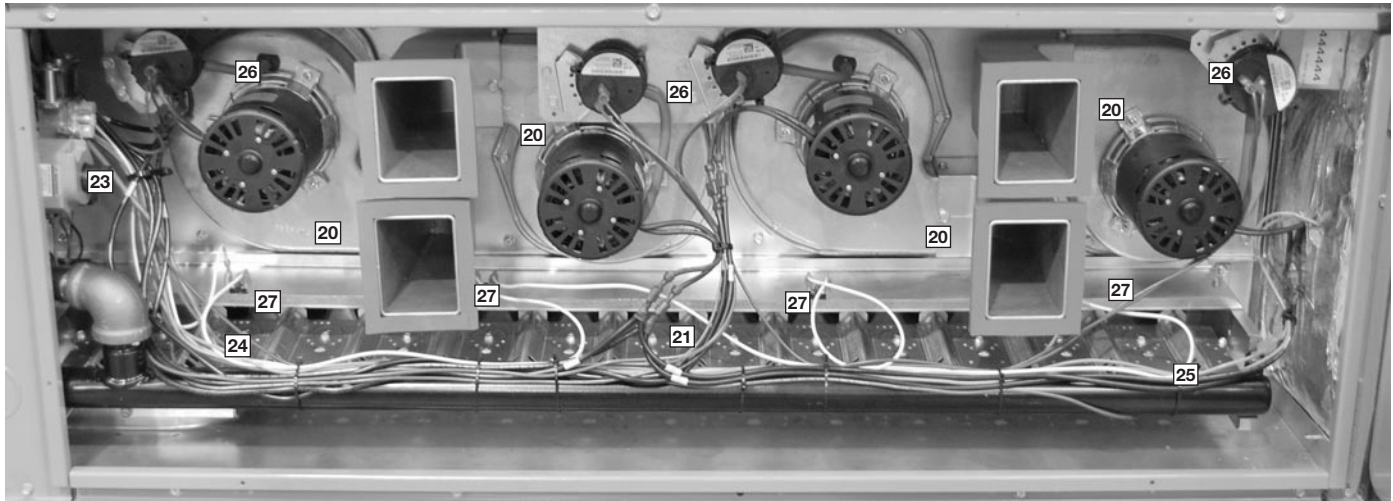

Compressor

The compressor compartment houses the heartbeat of the unit. The scroll compressors (28) are known for their long life and for reliable, quiet, and efficient operation. Each compressor has four rubber grommets (27) on the bottom for sound and vibration dampening. The suction and discharge lines are designed with shock loops to absorb the strain and stress that the starting torque, steady state operation, and shut down cycle impose on the refrigerant tubing. Each compressor and circuit are independent for built-in redundancy, and each circuit is clearly marked throughout the system. Each unit has 5 stages of cooling for precise supply air control.



Condenser Fans

The condenser fan motors (29) can easily be accessed and maintained through the top of the unit. A down-mount fan provides corrosion protection and easy removal. The polarized plug connection allows the motor to be changed quickly and eliminated the need to snake wires through the unit.

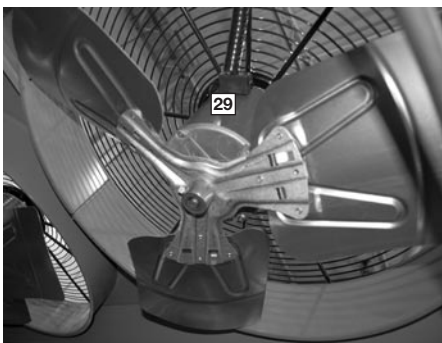

MicroChannel Condenser Technology

The outdoor coil uses the latest microchannel (30) technology for the most effective method of heat transfer. The outdoor coil is protected by optional louvered panels, which allow unobstructed airflow while protecting both the environment and vandalism.

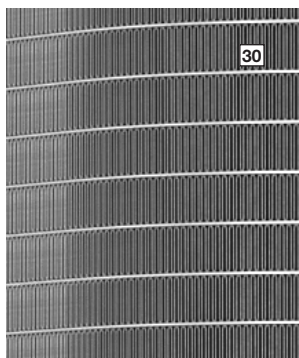

Economizers and Dampers

Each unit is designed for both downflow or horizontal applications for job configuration flexibility. The return air compartment can also contain an economizer. Two models exist: one for downflow applications, and one for horizontal applications. Each unit is pre-wired for the economizer to allow quick plug-in installation. The downflow economizer is also available as a factory-installed option. Power Exhaust is easily field-installed.

The economizer, which provides free cooling when outdoor conditions are suitable and also provides fresh air to meet local requirements, come standard with single enthalpy controls. The controls can be upgraded to dual enthalpy easily in the field. The direct drive actuator combined with gear drive dampers has eliminated the need for linkage adjustment in the field. The economizer control has a minimum position set-point, an outdoor-air set-point, a mix-air set-point, and a CO₂ set-point.

Barometric relief is standard on all economizers. The power exhaust is housed in the barometric relief opening and is easily slipped in with a plug-in assembly.

Roofcurb

The Friedrich® roofcurb (31) is made for toolless assembly at the jobsite by inserting a pin into a hinge in each corner of the adjacent curb sides (32), which makes the assembly process quick and easy.

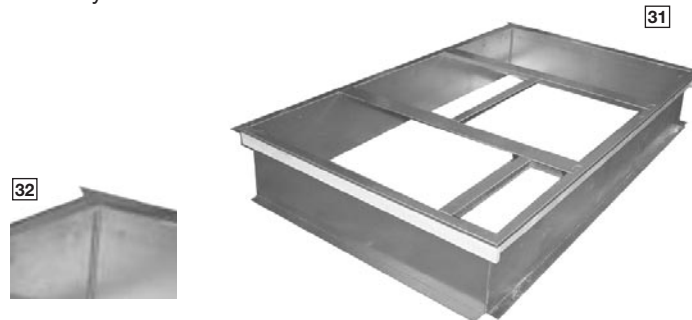

Variable Frequency Drive

The supply fan Variable Frequency Drive (VFD) (33) optimizes energy usage year round by providing a lower speed for first stage cooling operation, improving IEER's over the conventional constant fan system. Operating in the constant fan mode at the reduced speed can use as little as $\frac{1}{5}$ of the energy of a conventional constant fan system. Also, by operating at a lower speed on first stage cooling, up to 51% more moisture is removed, improving comfort during low load operation. The VFD supply fan meets California Title 24 and ASHRAE 90.1-2016 requirements for multi blower speed control. VFD also ramps up to the desired speed, reducing stress on the supply fan components and noise from a sudden inrush of air. Because the airflow is cut in half during first stage cooling and constant fan operation, noise is much less during these modes of operation.

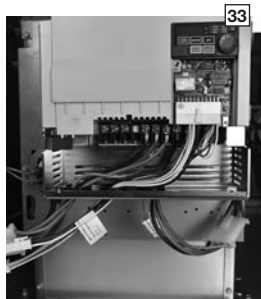

External Gauge Ports

The high (34) and low (35) external gauge ports are located in the outdoor section. With gauge ports mounted externally, an accurate diagnostic of system operation can be performed quickly and without removing exterior panels.



Variable Air Volume (VAV)

Single and Multi-Zone Variable Air Volume (VAV) allows for enhanced control of airflow and temperature in multiple building zones. Friedrich® VAV technology is compatible with industry standard zoning controls and zone systems. The controls vary the airflow and the cooling capacity to meet the demands of multiple zones. This increases the comfort and air quality of the environment.

R **GE** **H** **5** **U** **360** **A** **C** **G** **40** **B** **C** **A** ********
1 **23** **4** **5** **6** **789** **10** **11** **12** **13 14** **15** **16** **17** **18 19 20 21**

1—Brand

R = Friedrich®

2, 3—Unit Type

GE = Packaged Gas/Electric

4—Cabinet Type

H = Large Commercial
Extended

5—Cooling Series

5 = 5 stages of cooling

6—Efficiency Tier

U = High Efficiency

7,8,9—Capacity

360 = 27.5 ton

10—Major Series

A = 410A

11—Voltage

C = 3 phase 208-230/60

D = 3 phase 460/60

Y = 3 phase 575/60

12—Drive

F = Belt Drive - VFD Low

G = Belt Drive - VFD Medium

H = Belt Drive - VFD High

13, 14—Heat Capacity

30 = 300kW

40 = 400kW

15—Heat Configuration

2 = 2-Stage

B = 2-Stage Stainless

16—Control

C = ClearControl™ & Phase Monitor

D = ClearControl™ & Comfort Alert

17—Minor series

A = 1st design

18, 19, 20, 21—Option Code

AA0A

FACTORY INSTALLED OPTION CODES FOR RGEH (30 Ton)

18				19				20			21	
LV = Louver protection				DC = Disconnect				EC = Economizer			M8 = MERV 8 Filter	
HA = Hinged Access				NP = Non-Powered Convenience Outlet				SS = Supply & Return Smoke			M13 = MERV 13 Filter	
CC ¹ = Codenser Coil Coating												
				LF = Low Ambient & Freeze Stat				RS = Return Smoke				
OPTION CODE CHARACTER HIGHLIGHTED												
Opt.				Opt.				Opt.			Opt.	
A	None			A	None			0	None		A	None
B	LV			B	LF			1	EC		D	M8
C	HA			C	NP			2	RS		G	M13
D	LV	HA		D	LF	NP		3	EC	RS		
E	LV	CC		E	DC			4	SS			
F	LV	HA	CC	F	LF	DC		5	EC	SS		
				G	PC	DC						
				H	NP	DC						
				J	LF	PC	DC					
				K	LF	NP	DC					
				L	CB							
				M	LF	CB						
				N	PC	CB						
				P	NP	CB						
				Q	LF	PC	CB					
				R	LF	NP	CB					

FACTORY INSTALLED OPTION CODES FOR RGEH (30 Ton) (Con't.)

Instructions for Factory Installed Option(s) Selection

Note: Three characters following the model number will be utilized to designate a factory-installed option or combination of options. If no factory option(s) is required, "AAO" follows the model number.

- **Step 1:** In the table above, based on the desired features, choose option code character from highlighted options on the left side under the number 18. For example, the option code character "E" has Louver protection and Coil Coating.
- **Step 2:** In the table above, based on the desired features, choose option code character from highlighted options on the left side under the number 19. For example, the option code character "D" has Low Ambient / Freeze Stat and Non-powered convenience outlet.
- **Step 3:** In the table above, based on the desired features, choose option code character from highlighted options on the left side under the number 20. For example, the option code character "3" has Economizer and Return Smoke.
- **Step 4:** In the table above, based on the desired features, choose option code character from highlighted options on the left side under the number 21. For example, the option code character "D" has MERV 8 filters.
- The resulting option code from examples above is: "ED3D"
- **Step 5:** Add your option code selection to the end of model number

Example: RGEH5U360ACG302CA ED3D = RGEH5U360ACG302CAED3D

 Base model

 Option code

 = Model number with option code

To select an RGEH Cooling and Heating unit to meet a job requirement, follow this procedure, with example, using data supplied in this specification sheet.

1. DETERMINE COOLING AND HEATING REQUIREMENTS AND SPECIFIC OPERATING CONDITIONS FROM PLANS AND SPECS.

Example:

Voltage—	460V – 3 Phase – 60 Hz
Total Cooling Capacity—	340,000 BTUH [99.6 kW]
Sensible Cooling Capacity—	230,000 BTUH [67.4 kW]
Heating Capacity—	136,486 BTUH [40 kW]
*Condenser Entering Air—	95°F [35.0°C] DB
*Evaporator Mixed Air Entering—	67°F [19.4°C] WB 78°F [25.6°C] DB
*Indoor Air Flow—	11000 CFM [5191 L/s]
External Static Pressure—	1.2 in. WG [0.30 kPa]

2. SELECT UNIT TO MEET COOLING REQUIREMENTS.

Since total cooling is within range of a nominal 30 ton unit, use the cooling performance table at 95°F DB condenser inlet air. Interpolate between 9400 CFM [4436 L/s] and 13200 CFM [6230 L/s] to determine total and sensible capacity and Depression Ratio for inlet air at 11000 CFM [5191 L/s] indoor airflow (table basis):

Interpolation Formula:

$$MBH_1 + \left[(CFM - CFM_1) \times \left(\frac{MBH_2 - MBH_1}{CFM_2 - CFM_1} \right) \right] = MBH$$

Total Cooling Capacity = 350,000 BTUH [102.6 kW]
Sensible Cooling Capacity = 259,600 BTUH [76.1 kW]
DR = 0.105

When the entering dry bulb temperature (dbE) is not 80°F [26.7°C], the sensible capacity needs to be adjusted.
Note: total capacity is unaffected

Sensible Capacity Depression Formula:

$$Cap_{sensible} + [1.10 \times CFM \times (1 - DR) \times (dbE - 80)]$$

$$259,600 + [1.10 \times 11,000 \times (1 - 0.105) \times (78 - 80)]$$

Sensible Cooling Capacity = 237,941 BTUH

3. CORRECT CAPACITIES OF STEP 2 FOR ACTUAL AIR FLOW.

Select correction factors from the “Airflow Correction Factors” table at the design airflow, 11000 CFM [5191 L/s]. Multiply the gross and sensible capacities determined in Step 2 with these correction factors to obtain the corrected gross capacities. Note: These may have to be interpolated to obtain.

Total Capacity Correction Factor at 11000 CFM [5191 L/s] = 1.03

Sensible Capacity Correction Factor at 11000 CFM [5191 L/s] = 1.13

Corrected Total Capacity = 350,000 x 1.03 = 360,500 BTUH [105.7 kW]

Corrected Sensible Capacity = 237,941 x 1.13 = 268,873 BTUH [105.7 kW]

Note: These corrected capacities are Gross Capacities, not yet corrected for blower motor heat.

4. DETERMINE BLOWER SPEED AND BHP TO MEET SYSTEM DESIGN.

Total ESP (external static pressure) per the spec of 1.2 in WG [0.30 kPa] includes the system duct and grilles. Add from the table “Component Air Resistance”, 0.19 in. WG [0.05 kPa] for wet coil and 0.35 in. WG [0.09 kPa] for downflow to get an ESP of 1.74 in. WG [0.43 kPa]. Using the “Airflow Performance Table”, at the specified 11,000 CFM and 1.74 in. WG [0.43 kPa] ESP, determine blower BHP.

RPM = 1189
BHP = 12.98
DRIVE = H

5. CALCULATE INDOOR BLOWER BTUH HEAT EFFECT FROM MOTOR BHP IN STEP 4.

Assuming an average of 85% motor efficiency, determine the amount of heat generated by the blower motor at the specified CFM and ESP by dividing the BHP by the motor efficiency and solving for the difference. Convert this value from BTU to BTUH, multiplying by 2542.8 BTUH/BHP

RHP = 12.98 BHP = 12.98
AVG MOTOR EFFICIENCY = 85%

INDOOR BLOWER MOTOR HEAT =

$$\left[\left(\frac{BHP}{0.85} - BHP \right) \right] \times 2542.8$$

$$= [(12.98/0.85) - 12.98] \times 2542.8 = 5825 \text{ BTUH [1.71 kW]}$$

6. CALCULATE THE NET COOLING CAPACITIES

Net cooling capacities can be calculated by subtracting the motor heat from the gross cooling capacities.

Net Total Capacity = Gross Total Capacity – Indoor Blower Motor Heat
= 360,500 – 5,825 = 354,675 BTUH [103.9 kW]

Net Sensible Capacity = Gross Sensible Capacity – Indoor Blower Motor Heat
= 268,873 – 5,825 = 263,048 BTUH [77.1 kW]

7. SELECT UNIT HEATING CAPACITY

For Gas Heating, choose the gas heat capacity that closest matches the specified heat capacity requirements.

8. CHOOSE MODEL RGEH5U360ADH

[] Designates Metric Conversions

NOM. SIZES 27.5 TONS [96.7 kW] MODELS

Model RGEH5U Series	360ACF302	360ACF402	360ACG302	360ACG402
Cooling Performance^A				CONTINUED →
Gross Cooling Capacity Btu [kW]	340,000 [99.62]	340,000 [99.62]	340,000 [99.62]	340,000 [99.62]
EER ^B	9.8	9.8	9.8	9.8
IEER ^C	14.2	14.2	14.2	14.2
Nominal CFM/AHRI Rated CFM [L/s]	11000/9400 [5191/4436]	11000/9400 [5191/4436]	11000/9400 [5191/4436]	11000/9400 [5191/4436]
AHRI Net Cooling Capacity Btu [kW]	330,000 [96.69]	330,000 [96.69]	330,000 [96.69]	330,000 [96.69]
Net Sensible Capacity Btu [kW]	231,000 [67.68]	231,000 [67.68]	231,000 [67.68]	231,000 [67.68]
Net Latent Capacity Btu [kW]	99,000 [29.01]	99,000 [29.01]	99,000 [29.01]	99,000 [29.01]
Net System Power kW	33.6	33.6	33.6	33.6
Heating Performance (Gas)^D				
Heating Input Btu [kW] (1st Stage/2nd Stage)	150,000/300,000 [43.95/87.9]	200,000/400,000 [58.6/117.2]	150,000/300,000 [43.95/87.9]	200,000/400,000 [58.6/117.2]
Heating Output Btu [kW] (1st Stage/2nd Stage)	121,500/243,000 [35.6/71.2]	162,000/324,000 [47.47/94.93]	121,500/243,000 [35.6/71.2]	162,000/324,000 [47.47/94.93]
Temperature Rise Range °F [°C] (1st Stage/2nd Stage)	15-45 [8.3-25] / 15-45 [8.3-25]	25-55 [13.9-30.6] / 25-55 [13.9-30.6]	15-45 [8.3-25] / 15-45 [8.3-25]	25-55 [13.9-30.6] / 25-55 [13.9-30.6]
Steady State Efficiency (%)	81	81	81	81
No. Burners	12	14	12	14
No. Stages	2	2	2	2
Gas Connection Pipe Size in. [mm]	0.75 [19]	0.75 [19]	0.75 [19]	0.75 [19]
Compressor				
No./Type	2/Scroll	2/Scroll	2/Scroll	2/Scroll
Outdoor Coil—Fin Type				
Tube Type	Louvered	Louvered	Louvered	Louvered
MicroChannel Depth in. [mm]	1 [25.4]	1 [25.4]	1 [25.4]	1 [25.4]
Face Area sq. ft. [sq. m]	50.8 [4.72]	50.8 [4.72]	50.8 [4.72]	50.8 [4.72]
Rows/FPI [FPcm]	1 / 23 [9]	1 / 23 [9]	1 / 23 [9]	1 / 23 [9]
Indoor Coil—Fin Type				
Tube Type	Louvered	Louvered	Louvered	Louvered
Tube Size in. [mm] OD	Rifled	Rifled	Rifled	Rifled
Face Area sq. ft. [sq. m]	0.375 [9.5]	0.375 [9.5]	0.375 [9.5]	0.375 [9.5]
Rows/FPI [FPcm]	26.67 [2.48]	26.67 [2.48]	26.67 [2.48]	26.67 [2.48]
Refrigerant Control	4 / 15 [6]	4 / 15 [6]	4 / 15 [6]	4 / 15 [6]
Drain Connection No./Size in. [mm]	TX Valves	TX Valves	TX Valves	TX Valves
	1/1 [25.4]	1/1 [25.4]	1/1 [25.4]	1/1 [25.4]
Outdoor Fan—Type				
No. Used/Diameter in. [mm]	Propeller	Propeller	Propeller	Propeller
Drive Type/No. Speeds	6/24 [609.6]	6/24 [609.6]	6/24 [609.6]	6/24 [609.6]
CFM [L/s]	Direct/1	Direct/1	Direct/1	Direct/1
No. Motors/HP	19800 [9344]	19800 [9344]	19800 [9344]	19800 [9344]
Motor RPM	6 at 3/4 HP	6 at 3/4 HP	6 at 3/4 HP	6 at 3/4 HP
	1075	1075	1075	1075
Indoor Fan—Type				
No. Used/Diameter in. [mm]	FC Centrifugal	FC Centrifugal	FC Centrifugal	FC Centrifugal
Drive Type	2/18x9 [457x229]	2/18x9 [457x229]	2/18x9 [457x229]	2/18x9 [457x229]
No. Speeds	Direct	Direct	Direct	Direct
No. Motors	Multiple	Multiple	Multiple	Multiple
Motor HP	1	1	1	1
Motor RPM	7 1/2	7 1/2	10	10
Motor Frame Size	1760	1760	1760	1760
	213	213	215	215
Filter—Type				
Furnished	Disposable	Disposable	Disposable	Disposable
(NO.) Size Recommended in. [mm x mm x mm]	Yes	Yes	Yes	Yes
	(8)2x25x20 [51x635x508]	(8)2x25x20 [51x635x508]	(8)2x25x20 [51x635x508]	(8)2x25x20 [51x635x508]
Refrigerant Charge Oz. (Sys. 1/Sys. 2) [g]				
	273/245 [7740/6946]	273/245 [7740/6946]	273/245 [7740/6946]	273/245 [7740/6946]
Weights				
Net Weight lbs. [kg]	2400 [1089]	2400 [1089]	2400 [1089]	2400 [1089]
Ship Weight lbs. [kg]	2500 [1134]	2500 [1134]	2500 [1134]	2500 [1134]

See Page 20 for Notes.

[] Designates Metric Conversions

NOM. SIZES 27.5 TONS [96.7 kW] MODELS (Con't.)

Model RGEH5U Series	360ACH302	360ACH402	360ADF302	360ADF402
Cooling Performance^A				CONTINUED →
Gross Cooling Capacity Btu [kW]	340,000 [99.62]	340,000 [99.62]	340,000 [99.62]	340,000 [99.62]
EER ^B	9.8	9.8	9.8	9.8
IEER ^C	14.2	14.2	14.2	14.2
Nominal CFM/AHRI Rated CFM [L/s]	11000/9400 [5191/4436]	11000/9400 [5191/4436]	11000/9400 [5191/4436]	11000/9400 [5191/4436]
AHRI Net Cooling Capacity Btu [kW]	330,000 [96.69]	330,000 [96.69]	330,000 [96.69]	330,000 [96.69]
Net Sensible Capacity Btu [kW]	231,000 [67.68]	231,000 [67.68]	231,000 [67.68]	231,000 [67.68]
Net Latent Capacity Btu [kW]	99,000 [29.01]	99,000 [29.01]	99,000 [29.01]	99,000 [29.01]
Net System Power kW	33.6	33.6	33.6	33.6
Heating Performance (Gas)^D				
Heating Input Btu [kW] (1st Stage/2nd Stage)	150,000/300,000 [43.95/87.9]	200,000/400,000 [58.6/117.2]	150,000/300,000 [43.95/87.9]	200,000/400,000 [58.6/117.2]
Heating Output Btu [kW] (1st Stage/2nd Stage)	121,500/243,000 [35.6/71.2]	162,000/324,000 [47.47/94.93]	121,500/243,000 [35.6/71.2]	162,000/324,000 [47.47/94.93]
Temperature Rise Range °F [°C] (1st Stage/2nd Stage)	15-45 [8.3-25] / 15-45 [8.3-25]	25-55 [13.9-30.6] / 25-55 [13.9-30.6]	15-45 [8.3-25] / 15-45 [8.3-25]	25-55 [13.9-30.6] / 25-55 [13.9-30.6]
Steady State Efficiency (%)	81	81	81	81
No. Burners	12	14	12	14
No. Stages	2	2	2	2
Gas Connection Pipe Size in. [mm]	0.75 [19]	0.75 [19]	0.75 [19]	0.75 [19]
Compressor				
No./Type	2/Scroll	2/Scroll	2/Scroll	2/Scroll
Outdoor Coil—Fin Type				
Tube Type	Louvered	Louvered	Louvered	Louvered
MicroChannel Depth in. [mm]	MicroChannel	MicroChannel	MicroChannel	MicroChannel
Face Area sq. ft. [sq. m]	1 [25.4]	1 [25.4]	1 [25.4]	1 [25.4]
Rows/FPI [FPcm]	50.8 [4.72]	50.8 [4.72]	50.8 [4.72]	50.8 [4.72]
	1 / 23 [9]	1 / 23 [9]	1 / 23 [9]	1 / 23 [9]
Indoor Coil—Fin Type				
Tube Type	Louvered	Louvered	Louvered	Louvered
Tube Size in. [mm] OD	Rifled	Rifled	Rifled	Rifled
Face Area sq. ft. [sq. m]	0.375 [9.5]	0.375 [9.5]	0.375 [9.5]	0.375 [9.5]
Rows/FPI [FPcm]	26.67 [2.48]	26.67 [2.48]	26.67 [2.48]	26.67 [2.48]
Refrigerant Control	4 / 15 [6]	4 / 15 [6]	4 / 15 [6]	4 / 15 [6]
Drain Connection No./Size in. [mm]	TX Valves	TX Valves	TX Valves	TX Valves
	1/1 [25.4]	1/1 [25.4]	1/1 [25.4]	1/1 [25.4]
Outdoor Fan—Type				
No. Used/Diameter in. [mm]	Propeller	Propeller	Propeller	Propeller
Drive Type/No. Speeds	6/24 [609.6]	6/24 [609.6]	6/24 [609.6]	6/24 [609.6]
CFM [L/s]	Direct/1	Direct/1	Direct/1	Direct/1
No. Motors/HP	19800 [9344]	19800 [9344]	19800 [9344]	19800 [9344]
Motor RPM	6 at 3/4 HP	6 at 3/4 HP	6 at 3/4 HP	6 at 3/4 HP
	1075	1075	1075	1075
Indoor Fan—Type				
No. Used/Diameter in. [mm]	FC Centrifugal	FC Centrifugal	FC Centrifugal	FC Centrifugal
Drive Type	2/18x9 [457x229]	2/18x9 [457x229]	2/18x9 [457x229]	2/18x9 [457x229]
No. Speeds	Direct	Direct	Direct	Direct
No. Motors	Multiple	Multiple	Multiple	Multiple
Motor HP	1	1	1	1
Motor RPM	15	15	7 1/2	7 1/2
Motor Frame Size	3515	3515	1760	1760
	215	215	213	213
Filter—Type				
Furnished	Disposable	Disposable	Disposable	Disposable
(NO.) Size Recommended in. [mm x mm x mm]	Yes	Yes	Yes	Yes
	(8)2x25x20 [51x635x508]	(8)2x25x20 [51x635x508]	(8)2x25x20 [51x635x508]	(8)2x25x20 [51x635x508]
Refrigerant Charge Oz. (Sys. 1/Sys. 2) [g]				
	273/245 [7740/6946]	273/245 [7740/6946]	273/245 [7740/6946]	273/245 [7740/6946]
Weights				
Net Weight lbs. [kg]	2400 [1089]	2400 [1089]	2400 [1089]	2400 [1089]
Ship Weight lbs. [kg]	2500 [1134]	2500 [1134]	2500 [1134]	2500 [1134]

See Page 20 for Notes.

[] Designates Metric Conversions

NOM. SIZES 27.5 TONS [96.7 kW] MODELS (Con't.)

Model RGEH5U Series	360ADG302	360ADG402	360ADH302	360ADH402
Cooling Performance^A				CONTINUED →
Gross Cooling Capacity Btu [kW]	340,000 [99.62]	340,000 [99.62]	340,000 [99.62]	340,000 [99.62]
EER ^B	9.8	9.8	9.8	9.8
IEERC ^C	14.2	14.2	14.2	14.2
Nominal CFM/AHRI Rated CFM [L/s]	11000/9400 [5191/4436]	11000/9400 [5191/4436]	11000/9400 [5191/4436]	11000/9400 [5191/4436]
AHRI Net Cooling Capacity Btu [kW]	330,000 [96.69]	330,000 [96.69]	330,000 [96.69]	330,000 [96.69]
Net Sensible Capacity Btu [kW]	231,000 [67.68]	231,000 [67.68]	231,000 [67.68]	231,000 [67.68]
Net Latent Capacity Btu [kW]	99,000 [29.01]	99,000 [29.01]	99,000 [29.01]	99,000 [29.01]
Net System Power kW	33.6	33.6	33.6	33.6
Heating Performance (Gas)^P				
Heating Input Btu [kW] (1st Stage/2nd Stage)	150,000/300,000 [43.95/87.9]	200,000/400,000 [58.6/117.2]	150,000/300,000 [43.95/87.9]	200,000/400,000 [58.6/117.2]
Heating Output Btu [kW] (1st Stage/2nd Stage)	121,500/243,000 [35.6/71.2]	162,000/324,000 [47.47/94.93]	121,500/243,000 [35.6/71.2]	162,000/324,000 [47.47/94.93]
Temperature Rise Range °F [°C] (1st Stage/2nd Stage)	15-45 [8.3-25] / 15-45 [8.3-25]	25-55 [13.9-30.6] / 25-55 [13.9-30.6]	15-45 [8.3-25] / 5-45 [8.3-25]	25-55 [13.9-30.6] / 25-55 [13.9-30.6]
Steady State Efficiency (%)	81	81	81	81
No. Burners	12	14	12	14
No. Stages	2	2	2	2
Gas Connection Pipe Size in. [mm]	0.75 [19]	0.75 [19]	0.75 [19]	0.75 [19]
Compressor				
No./Type	2/Scroll	2/Scroll	2/Scroll	2/Scroll
Outdoor Coil—Fin Type				
Tube Type	Louvered	Louvered	Louvered	Louvered
MicroChannel Depth in. [mm]	1 [25.4]	1 [25.4]	1 [25.4]	1 [25.4]
Face Area sq. ft. [sq. m]	50.8 [4.72]	50.8 [4.72]	50.8 [4.72]	50.8 [4.72]
Rows/FPI [FPcm]	1 / 23 [9]	1 / 23 [9]	1 / 23 [9]	1 / 23 [9]
Indoor Coil—Fin Type				
Tube Type	Louvered	Louvered	Louvered	Louvered
Tube Size in. [mm] OD	0.375 [9.5]	0.375 [9.5]	0.375 [9.5]	0.375 [9.5]
Face Area sq. ft. [sq. m]	26.67 [2.48]	26.67 [2.48]	26.67 [2.48]	26.67 [2.48]
Rows/FPI [FPcm]	4 / 15 [6]	4 / 15 [6]	4 / 15 [6]	4 / 15 [6]
Refrigerant Control	TX Valves	TX Valves	TX Valves	TX Valves
Drain Connection No./Size in. [mm]	1/1 [25.4]	1/1 [25.4]	1/1 [25.4]	1/1 [25.4]
Outdoor Fan—Type				
No. Used/Diameter in. [mm]	6/24 [609.6]	6/24 [609.6]	6/24 [609.6]	6/24 [609.6]
Drive Type/No. Speeds	Direct/1	Direct/1	Direct/1	Direct/1
CFM [L/s]	19800 [9344]	19800 [9344]	19800 [9344]	19800 [9344]
No. Motors/HP	6 at 3/4 HP	6 at 3/4 HP	6 at 3/4 HP	6 at 3/4 HP
Motor RPM	1075	1075	1075	1075
Indoor Fan—Type				
No. Used/Diameter in. [mm]	2/18x9 [457x229]	2/18x9 [457x229]	2/18x9 [457x229]	2/18x9 [457x229]
Drive Type	Direct	Direct	Direct	Direct
No. Speeds	Multiple	Multiple	Multiple	Multiple
No. Motors	1	1	1	1
Motor HP	10	10	15	15
Motor RPM	1760	1760	3515	3515
Motor Frame Size	215	215	215	215
Filter—Type				
Furnished	Yes	Yes	Yes	Yes
(NO.) Size Recommended in. [mm x mm x mm]	(8)2x25x20 [51x635x508]	(8)2x25x20 [51x635x508]	(8)2x25x20 [51x635x508]	(8)2x25x20 [51x635x508]
Refrigerant Charge Oz. (Sys. 1/Sys. 2) [g]				
	273/245 [7740/6946]	273/245 [7740/6946]	273/245 [7740/6946]	273/245 [7740/6946]
Weights				
Net Weight lbs. [kg]	2400 [1089]	2400 [1089]	2400 [1089]	2400 [1089]
Ship Weight lbs. [kg]	2500 [1134]	2500 [1134]	2500 [1134]	2500 [1134]

See Page 20 for Notes.

[] Designates Metric Conversions

NOM. SIZES 27.5 TONS [96.7 kW] MODELS (Con't.)

Model RGEH5U Series	360AYF302	360AYF402	360AYG302	360AYG402
Cooling Performance^A				CONTINUED →
Gross Cooling Capacity Btu [kW]	340,000 [99.62]	340,000 [99.62]	340,000 [99.62]	340,000 [99.62]
EER ^B	9.8	9.8	9.8	9.8
IEERC ^C	14.2	14.2	14.2	14.2
Nominal CFM/AHRI Rated CFM [L/s]	11000/9400 [5191/4436]	11000/9400 [5191/4436]	11000/9400 [5191/4436]	11000/9400 [5191/4436]
AHRI Net Cooling Capacity Btu [kW]	330,000 [96.69]	330,000 [96.69]	330,000 [96.69]	330,000 [96.69]
Net Sensible Capacity Btu [kW]	231,000 [67.68]	231,000 [67.68]	231,000 [67.68]	231,000 [67.68]
Net Latent Capacity Btu [kW]	99,000 [29.01]	99,000 [29.01]	99,000 [29.01]	99,000 [29.01]
Net System Power kW	33.6	33.6	33.6	33.6
Heating Performance (Gas)^D				
Heating Input Btu [kW] (1st Stage/2nd Stage)	150,000/300,000 [43.95/87.9]	200,000/400,000 [58.6/117.2]	150,000/300,000 [43.95/87.9]	200,000/400,000 [58.6/117.2]
Heating Output Btu [kW] (1st Stage/2nd Stage)	121,500/243,000 [35.6/71.2]	162,000/324,000 [47.47/94.93]	121,500/243,000 [35.6/71.2]	162,000/324,000 [47.47/94.93]
Temperature Rise Range °F [°C] (1st Stage/2nd Stage)	15-45 [8.3-25] / 15-45 [8.3-25]	25-55 [13.9-30.6] / 25-55 [13.9-30.6]	15-45 [8.3-25] / 15-45 [8.3-25]	25-55 [13.9-30.6] / 25-55 [13.9-30.6]
Steady State Efficiency (%)	81	81	81	81
No. Burners	12	14	12	14
No. Stages	2	2	2	2
Gas Connection Pipe Size in. [mm]	0.75 [19]	0.75 [19]	0.75 [19]	0.75 [19]
Compressor				
No./Type	2/Scroll	2/Scroll	2/Scroll	2/Scroll
Outdoor Coil—Fin Type				
Tube Type	Louvered	Louvered	Louvered	Louvered
MicroChannel Depth in. [mm]	MicroChannel	MicroChannel	MicroChannel	MicroChannel
Face Area sq. ft. [sq. m]	1 [25.4]	1 [25.4]	1 [25.4]	1 [25.4]
Rows/FPI [FPcm]	50.8 [4.72]	50.8 [4.72]	50.8 [4.72]	50.8 [4.72]
	1 / 23 [9]	1 / 23 [9]	1 / 23 [9]	1 / 23 [9]
Indoor Coil—Fin Type				
Tube Type	Louvered	Louvered	Louvered	Louvered
Tube Size in. [mm] OD	Rifled	Rifled	Rifled	Rifled
Face Area sq. ft. [sq. m]	0.375 [9.5]	0.375 [9.5]	0.375 [9.5]	0.375 [9.5]
Rows/FPI [FPcm]	26.67 [2.48]	26.67 [2.48]	26.67 [2.48]	26.67 [2.48]
Refrigerant Control	4 / 15 [6]	4 / 15 [6]	4 / 15 [6]	4 / 15 [6]
Drain Connection No./Size in. [mm]	TX Valves	TX Valves	TX Valves	TX Valves
	1/1 [25.4]	1/1 [25.4]	1/1 [25.4]	1/1 [25.4]
Outdoor Fan—Type				
No. Used/Diameter in. [mm]	Propeller	Propeller	Propeller	Propeller
Drive Type/No. Speeds	6/24 [609.6]	6/24 [609.6]	6/24 [609.6]	6/24 [609.6]
CFM [L/s]	Direct/1	Direct/1	Direct/1	Direct/1
No. Motors/HP	19800 [9344]	19800 [9344]	19800 [9344]	19800 [9344]
Motor RPM	6 at 3/4 HP	6 at 3/4 HP	6 at 3/4 HP	6 at 3/4 HP
	1075	1075	1075	1075
Indoor Fan—Type				
No. Used/Diameter in. [mm]	FC Centrifugal	FC Centrifugal	FC Centrifugal	FC Centrifugal
Drive Type	2/18x9 [457x229]	2/18x9 [457x229]	2/18x9 [457x229]	2/18x9 [457x229]
No. Speeds	Direct	Direct	Direct	Direct
No. Motors	Multiple	Multiple	Multiple	Multiple
Motor HP	1	1	1	1
Motor RPM	7 1/2	7 1/2	10	10
Motor Frame Size	1760	1760	1760	1760
	213	213	215	215
Filter—Type				
Furnished	Disposable	Disposable	Disposable	Disposable
(NO.) Size Recommended in. [mm x mm x mm]	Yes	Yes	Yes	Yes
	(8)2x25x20 [51x635x508]	(8)2x25x20 [51x635x508]	(8)2x25x20 [51x635x508]	(8)2x25x20 [51x635x508]
Refrigerant Charge Oz. (Sys. 1/Sys. 2) [g]				
	273/245 [7740/6946]	273/245 [7740/6946]	273/245 [7740/6946]	273/245 [7740/6946]
Weights				
Net Weight lbs. [kg]	2400 [1089]	2400 [1089]	2400 [1089]	2400 [1089]
Ship Weight lbs. [kg]	2500 [1134]	2500 [1134]	2500 [1134]	2500 [1134]

See Page 20 for Notes.

[] Designates Metric Conversions

NOM. SIZES 27.5 TONS [96.7 kW] MODELS (Con't.)

Model RGEH5U Series	360AYH302	360AYH402
Cooling Performance^A		
Gross Cooling Capacity Btu [kW]	340,000 [99.62]	340,000 [99.62]
EER ^B	9.8	9.8
IEERC ^C	14.2	14.2
Nominal CFM/AHRI Rated CFM [L/s]	11000/9400 [5191/4436]	11000/9400 [5191/4436]
AHRI Net Cooling Capacity Btu [kW]	330,000 [96.69]	330,000 [96.69]
Net Sensible Capacity Btu [kW]	231,000 [67.68]	231,000 [67.68]
Net Latent Capacity Btu [kW]	99,000 [29.01]	99,000 [29.01]
Net System Power kW	33.6	33.6
Heating Performance (Gas)^P		
Heating Input Btu [kW] (1st Stage/2nd Stage)	150,000/300,000 [43.95/87.9]	200,000/400,000 [58.6/117.2]
Heating Output Btu [kW] (1st Stage/2nd Stage)	121,500/243,000 [35.6/71.2]	162,000/324,000 [47.47/94.93]
Temperature Rise Range °F [°C] (1st Stage/2nd Stage)	15-45 [8.3-25] / 15-45 [8.3-25]	25-55 [13.9-30.6] / 25-55 [13.9-30.6]
Steady State Efficiency (%)	81	81
No. Burners	12	14
No. Stages	2	2
Gas Connection Pipe Size in. [mm]	0.75 [19]	0.75 [19]
Compressor		
No./Type	2/Scroll	2/Scroll
Outdoor Coil—Fin Type		
	Louvered	Louvered
Tube Type	MicroChannel	MicroChannel
MicroChannel Depth in. [mm]	1 [25.4]	1 [25.4]
Face Area sq. ft. [sq. m]	50.8 [4.72]	50.8 [4.72]
Rows/FPI [FPcm]	1 / 23 [9]	1 / 23 [9]
Indoor Coil—Fin Type		
	Louvered	Louvered
Tube Type	Rifled	Rifled
Tube Size in. [mm] OD	0.375 [9.5]	0.375 [9.5]
Face Area sq. ft. [sq. m]	26.67 [2.48]	26.67 [2.48]
Rows/FPI [FPcm]	4 / 15 [6]	4 / 15 [6]
Refrigerant Control	TX Valves	TX Valves
Drain Connection No./Size in. [mm]	1/1 [25.4]	1/1 [25.4]
Outdoor Fan—Type		
	Propeller	Propeller
No. Used/Diameter in. [mm]	6/24 [609.6]	6/24 [609.6]
Drive Type/No. Speeds	Direct/1	Direct/1
CFM [L/s]	19800 [9344]	19800 [9344]
No. Motors/HP	6 at 3/4 HP	6 at 3/4 HP
Motor RPM	1075	1075
Indoor Fan—Type		
	FC Centrifugal	FC Centrifugal
No. Used/Diameter in. [mm]	2/18x9 [457x229]	2/18x9 [457x229]
Drive Type	Direct	Direct
No. Speeds	Multiple	Multiple
No. Motors	1	1
Motor HP	15	15
Motor RPM	3535	3535
Motor Frame Size	215	215
Filter—Type		
	Disposable	Disposable
Furnished	Yes	Yes
(NO.) Size Recommended in. [mm x mm x mm]	(8)2x25x20 [51x635x508]	(8)2x25x20 [51x635x508]
Refrigerant Charge Oz. (Sys. 1/Sys. 2) [g]		
	273/245 [7740/6946]	273/245 [7740/6946]
Weights		
Net Weight lbs. [kg]	2400 [1089]	2400 [1089]
Ship Weight lbs. [kg]	2500 [1134]	2500 [1134]

See Page 20 for Notes.

[] Designates Metric Conversions

NOTES:

- A. Cooling Performance is rated at 95° F ambient, 80° F entering dry bulb, 67° F entering wet bulb. Gross capacity does not include the effect of fan motor heat. AHRI capacity is net and includes the effect of fan motor heat. Units are suitable for operation to $\pm 20\%$ of nominal cfm. Units are certified in accordance with the Unitary Air Conditioner Equipment certification program, which is based on AHRI Standard 340/360.
- B. EER and Integrated Energy Efficiency Ratio (IEER) is rated at AHRI conditions in accordance with AHRI Standard 340/360.
- C. Heating Performance limit settings and rating data were established and approved under laboratory test conditions using American National Standard Institute standards. Ratings shown are for elevations up to 2000 feet. For elevations above 2000 feet, ratings should be reduced at the rate of 4% for each 1000 feet above sea level.

COOLING PERFORMANCE DATA - RGEH5U360A

ENTERING INDOOR AIR @ 80°F [26.7°C] dB _E ①										
wBE	71°F [21.7°C]		67°F [19.4°C]		63°F [17.2°C]		61°F [16.1°C]		59°F [15.0°C]	
	13200 [6230]	9400 [4436]	8800 [4153]	8000 [4436]	13200 [6230]	9400 [6230]	8800 [4153]	8000 [4153]	13200 [6230]	9400 [4436]
CFM [L/s]	0.14	0.08	0.07	0.08	0.14	0.14	0.07	0.07	0.14	0.08
Total BTUH [kW]	405.9 [118.9]	378.1 [110.8]	373.7 [109.5]	361.6 [106.0]	357.4 [104.7]	375.9 [110.2]	346.1 [101.4]	343.2 [100.6]	372.2 [109.1]	346.7 [101.6]
Sens BTUH [kW]	258.3 [75.7]	217.3 [63.7]	210.9 [61.8]	249.4 [73.1]	242.0 [70.9]	332.0 [97.3]	279.3 [81.9]	284.2 [83.3]	362.9 [106.3]	305.3 [89.5]
Power	29.3	28.3	28.1	29.1	27.9	29.0	28.0	27.8	28.8	27.8
Total BTUH [kW]	400.7 [117.4]	373.3 [109.4]	368.9 [108.1]	356.7 [104.5]	352.6 [103.3]	370.7 [108.6]	345.4 [101.2]	344.1 [100.3]	367.0 [107.5]	341.8 [100.2]
Sens BTUH [kW]	256.1 [75.0]	215.4 [63.1]	209.0 [61.2]	247.5 [72.5]	240.1 [70.4]	329.8 [96.6]	277.4 [81.3]	282.4 [82.7]	360.6 [105.7]	303.4 [88.9]
Power	29.9	28.8	28.7	29.7	28.5	29.6	28.5	28.4	29.4	28.2
Total BTUH [kW]	395.0 [115.8]	368.0 [107.8]	363.7 [106.6]	351.4 [103.0]	347.3 [101.8]	365.1 [107.0]	340.1 [99.7]	336.1 [98.8]	361.3 [105.9]	336.6 [98.6]
Sens BTUH [kW]	253.5 [74.3]	213.3 [62.5]	207.0 [60.6]	245.4 [71.9]	238.1 [69.8]	327.2 [95.9]	275.3 [80.7]	267.1 [78.3]	358.1 [104.9]	301.2 [88.3]
Power	30.5	29.5	29.3	29.3	29.2	30.2	29.2	29.0	30.1	29.0
Total BTUH [kW]	388.9 [114.0]	362.2 [106.2]	358.0 [104.9]	345.7 [101.3]	341.7 [100.1]	358.9 [105.2]	334.3 [98.0]	330.4 [96.8]	355.1 [104.1]	330.8 [96.9]
Sens BTUH [kW]	250.8 [73.5]	211.0 [61.8]	204.7 [60.0]	243.0 [71.2]	235.8 [69.1]	324.5 [95.1]	273.0 [80.0]	264.8 [77.6]	355.1 [104.1]	298.9 [87.6]
Power	31.3	30.2	30.0	30.0	29.9	31.0	29.9	29.7	30.8	29.7
Total BTUH [kW]	382.2 [112.0]	356.0 [104.3]	351.9 [103.1]	364.4 [106.8]	339.5 [99.5]	352.2 [103.2]	328.1 [96.2]	324.3 [95.0]	349.1 [102.3]	325.2 [95.3]
Sens BTUH [kW]	247.7 [72.6]	208.4 [61.1]	202.2 [59.3]	240.5 [70.5]	233.3 [68.4]	321.4 [94.2]	270.4 [79.2]	262.3 [76.9]	337.6 [99.9]	284.0 [83.2]
Power	32.1	31.0	30.8	31.9	30.6	31.8	30.7	30.5	31.7	30.6
Total BTUH [kW]	375.1 [109.9]	349.4 [102.4]	345.3 [101.2]	357.3 [104.7]	332.8 [97.5]	329.0 [96.4]	345.1 [101.1]	317.8 [93.1]	341.9 [100.2]	318.5 [93.3]
Sens BTUH [kW]	244.4 [71.6]	205.6 [60.3]	199.5 [58.5]	237.7 [69.7]	230.6 [67.6]	318.1 [93.2]	267.6 [78.4]	259.6 [76.1]	334.3 [98.0]	281.2 [82.4]
Power	32.9	31.8	31.6	32.8	31.7	32.6	31.5	31.3	32.6	31.4
Total BTUH [kW]	367.5 [107.7]	342.3 [100.3]	338.3 [99.1]	349.7 [102.5]	325.7 [95.5]	322.0 [94.3]	337.5 [98.9]	314.4 [91.7]	334.3 [98.0]	311.4 [91.3]
Sens BTUH [kW]	240.8 [70.6]	202.6 [59.4]	196.6 [57.6]	279.0 [81.8]	234.7 [68.8]	227.7 [66.7]	314.5 [92.2]	264.6 [77.5]	330.7 [96.9]	278.2 [81.5]
Power	33.9	32.7	32.5	33.7	32.6	32.4	33.6	32.2	33.5	32.3
Total BTUH [kW]	359.4 [105.3]	334.8 [98.1]	330.9 [97.0]	341.6 [100.1]	318.2 [93.2]	314.5 [92.2]	329.4 [96.5]	306.8 [89.9]	326.2 [95.6]	303.9 [88.9]
Sens BTUH [kW]	237.0 [69.5]	199.4 [58.4]	193.5 [56.7]	275.2 [80.6]	231.5 [67.8]	224.6 [65.8]	310.7 [91.1]	261.4 [76.6]	326.2 [95.6]	275.0 [80.6]
Power	34.9	33.7	33.5	34.7	33.5	33.4	34.6	33.4	34.5	33.3
Total BTUH [kW]	350.8 [102.8]	326.8 [95.8]	323.0 [94.6]	333.0 [97.6]	310.2 [90.9]	306.6 [89.8]	320.8 [94.0]	298.8 [87.6]	317.6 [93.1]	295.9 [86.7]
Sens BTUH [kW]	232.9 [68.3]	196.0 [57.4]	190.1 [55.7]	271.1 [79.4]	228.0 [66.8]	221.3 [64.8]	306.6 [89.9]	258.0 [75.6]	317.6 [93.1]	271.6 [79.6]
Power	36.0	34.7	34.5	35.8	35.7	34.4	35.7	34.4	35.6	34.4
Total BTUH [kW]	341.7 [100.1]	318.3 [93.3]	314.6 [92.2]	323.9 [94.9]	301.7 [88.4]	298.2 [87.4]	311.7 [91.3]	290.4 [84.1]	308.6 [90.4]	287.4 [84.2]
Sens BTUH [kW]	228.6 [67.0]	192.3 [56.4]	186.6 [54.7]	266.7 [78.2]	224.4 [65.8]	217.7 [63.8]	302.3 [88.6]	254.3 [74.5]	308.6 [90.4]	267.9 [78.5]
Power	37.1	35.8	35.6	37.0	35.7	35.5	36.8	35.5	36.7	35.5
Total BTUH [kW]	332.1 [97.3]	309.4 [90.7]	305.8 [89.6]	314.4 [92.1]	292.8 [85.8]	289.4 [84.8]	302.2 [88.5]	281.5 [82.5]	299.0 [87.6]	278.5 [81.6]
Sens BTUH [kW]	224.0 [65.6]	188.4 [55.2]	182.8 [53.6]	262.1 [76.8]	220.5 [64.6]	213.9 [62.7]	297.7 [87.2]	250.4 [73.4]	299.0 [87.6]	264.0 [77.4]
Power	38.3	37.0	36.8	38.2	36.8	36.6	38.0	36.7	37.9	36.6

DR — Depression ratio
dB_E — Entering air dry bulb
wBE — Entering air wet bulb

[] Designates Metric Conversions

Total — Total capacity x 1000 BTUH
Sens — Sensible capacity x 1000 BTUH
Power — KW input

NOTES: ① When the entering air dry bulb is other than 80°F [27°C], adjust the sensible capacity from the table by adding [(1.10 x CFM x (t₁ - DR)) x (dB_E - 80)].

HEATING PERFORMANCE DATA

	RGEH5U360A**30	RGEH5U360A**40
Heating Input Btu [KW] (1st Stage / 2nd Stage)	150,000 / 300,000 [43.95 / 87.9]	200,000 / 400,000 [58.6 / 117.2]
Heating Output Btu [KW] (1st Stage / 2nd Stage)	121,500 / 243,000 [35.6 / 71.2]	162,000 / 324,000 [47.47 / 94.93]
Temperature Rise Range °F [°C] (1st Stage / 2nd Stage)	15 - 45 [8.3 - 25] / 15 - 45 [8.3 - 25]	25 - 55 [13.9 - 30.6] / 25 - 55 [13.9 - 30.6]
Number of Burners	12	14
Number of Stages	2	2
Main Limit Temperature °F	135	150
Rollout Limit Temperature °F	350	350
Max Outlet Air Temperature [°C]	180	170
Steady State Efficiency (%)	81	81
Gas Connection Pipe Size in. [mm]	1.00 [25.4]	1.00 [25.4]

[] Designates Metric Conversions

AIRFLOW PERFORMANCE — 27.5 TON [96.7 kW] — 60 Hz — DOWNFLOW

Air Flow CFM (L/s)		External Static Pressure — inches of Water [kPa]																												
		0.1 [.02]	0.2 [.05]	0.3 [.07]	0.4 [.10]	0.5 [.12]	0.6 [.15]	0.7 [.17]	0.8 [.20]	0.9 [.22]	1.0 [.25]	1.1 [.27]	1.2 [.30]	1.3 [.32]	1.4 [.35]	1.5 [.37]	1.6 [.40]	1.7 [.42]	1.8 [.45]	1.9 [.47]	2.0 [.50]									
8000 [3775]	—	—	—	—	—	800 [453]	817 [471]	835 [490]	852 [509]	870 [529]	888 [548]	906 [569]	924 [589]	943 [610]	961 [631]	980 [653]	999 [675]	1019 [697]	1038 [720]	1058 [743]	—	—	—	—	—	—	—	—		
8200 [3869]	—	—	—	796 [460]	813 [478]	830 [497]	847 [517]	865 [536]	882 [556]	900 [577]	918 [597]	936 [619]	955 [640]	973 [662]	992 [684]	1011 [707]	1030 [730]	1049 [753]	1069 [777]	—	—	—	—	—	—	—	—	—	—	
8400 [3964]	—	—	—	809 [468]	826 [505]	843 [524]	860 [544]	877 [565]	895 [585]	912 [606]	930 [628]	948 [650]	967 [672]	985 [694]	1004 [717]	1023 [740]	1042 [764]	1061 [788]	1080 [812]	—	—	—	—	—	—	—	—	—	—	
8600 [4058]	—	—	—	805 [494]	822 [513]	839 [533]	855 [553]	873 [574]	890 [595]	907 [616]	925 [637]	943 [659]	961 [682]	979 [705]	997 [728]	1016 [751]	1035 [775]	1054 [799]	1073 [824]	1092 [849]	—	—	—	—	—	—	—	—	—	—
8800 [4153]	—	—	802 [502]	819 [522]	835 [542]	852 [562]	869 [583]	886 [604]	903 [626]	920 [648]	938 [670]	955 [692]	973 [715]	991 [739]	1010 [762]	1028 [787]	1047 [811]	1066 [836]	1085 [861]	1104 [887]	—	—	—	—	—	—	—	—	—	—
9000 [4247]	—	—	816 [531]	832 [551]	849 [572]	865 [593]	882 [614]	899 [636]	916 [658]	933 [680]	950 [704]	968 [727]	986 [750]	1004 [774]	1022 [799]	1040 [823]	1059 [848]	1078 [874]	1097 [900]	1116 [926]	—	—	—	—	—	—	—	—	—	—
9200 [4341]	798 [521]	814 [541]	830 [561]	846 [582]	862 [604]	879 [625]	895 [647]	912 [670]	929 [692]	946 [715]	963 [739]	981 [763]	999 [787]	1017 [811]	1035 [836]	1053 [862]	1071 [887]	1090 [913]	1109 [940]	1128 [966]	—	—	—	—	—	—	—	—	—	—
9400 [4436]	813 [551]	828 [572]	844 [593]	860 [615]	876 [636]	892 [659]	909 [681]	925 [704]	942 [728]	959 [751]	977 [775]	994 [800]	1012 [825]	1029 [850]	1047 [875]	1066 [901]	1084 [927]	1102 [954]	1121 [981]	1140 [1008]	—	—	—	—	—	—	—	—	—	—
9600 [4530]	827 [583]	842 [604]	858 [626]	874 [648]	890 [671]	906 [693]	922 [717]	939 [740]	956 [764]	973 [788]	990 [813]	1007 [838]	1025 [864]	1042 [889]	1060 [915]	1078 [942]	1097 [969]	1115 [996]	1134 [1024]	1152 [1052]	—	—	—	—	—	—	—	—	—	—
9800 [4624]	841 [616]	857 [638]	872 [660]	888 [683]	904 [706]	920 [730]	936 [753]	953 [778]	969 [802]	986 [827]	1003 [852]	1020 [878]	1038 [904]	1055 [930]	1073 [957]	1091 [984]	1109 [1012]	1128 [1040]	1146 [1068]	1165 [1096]	—	—	—	—	—	—	—	—	—	—
10000 [4719]	856 [651]	871 [673]	887 [696]	902 [720]	918 [743]	934 [767]	950 [792]	967 [816]	983 [842]	1000 [867]	1017 [893]	1034 [919]	1051 [946]	1069 [973]	1086 [1000]	1104 [1028]	1122 [1056]	1141 [1084]	1159 [1113]	1178 [1142]	—	—	—	—	—	—	—	—	—	—
10200 [4813]	871 [687]	896 [710]	901 [733]	917 [757]	932 [782]	948 [806]	964 [831]	981 [857]	997 [882]	1014 [908]	1031 [935]	1048 [962]	1065 [989]	1082 [1017]	1100 [1045]	1118 [1073]	1135 [1102]	1154 [1131]	1172 [1160]	1190 [1190]	—	—	—	—	—	—	—	—	—	—
10400 [4908]	885 [724]	900 [748]	916 [772]	931 [796]	947 [821]	963 [846]	979 [872]	995 [898]	1011 [924]	1028 [951]	1044 [978]	1061 [1006]	1078 [1034]	1096 [1062]	1113 [1090]	1131 [1119]	1149 [1149]	1167 [1178]	1185 [1208]	1203 [1239]	—	—	—	—	—	—	—	—	—	—
10600 [5002]	900 [762]	915 [787]	931 [812]	946 [837]	961 [862]	977 [888]	993 [914]	1009 [941]	1025 [968]	1042 [995]	1058 [1023]	1075 [1051]	1092 [1079]	1109 [1108]	1127 [1137]	1144 [1167]	1162 [1197]	1180 [1227]	1198 [1258]	1217 [1289]	—	—	—	—	—	—	—	—	—	—
10800 [5096]	916 [802]	930 [827]	946 [853]	961 [879]	976 [905]	992 [931]	1008 [958]	1024 [985]	1040 [1013]	1056 [1041]	1073 [1069]	1089 [1098]	1106 [1127]	1123 [1156]	1141 [1186]	1158 [1216]	1176 [1247]	1194 [1277]	1212 [1309]	1230 [1340]	—	—	—	—	—	—	—	—	—	—
11000 [5191]	931 [844]	946 [869]	961 [895]	976 [922]	991 [948]	1007 [976]	1022 [1003]	1038 [1031]	1054 [1059]	1071 [1088]	1087 [1116]	1104 [1146]	1120 [1175]	1137 [1205]	1155 [1236]	1172 [1267]	1189 [1298]	1207 [1329]	1225 [1361]	1243 [1393]	—	—	—	—	—	—	—	—	—	—
11200 [5285]	946 [887]	961 [913]	976 [939]	991 [966]	1006 [994]	1022 [1021]	1037 [1049]	1053 [1078]	1069 [1107]	1085 [1165]	1101 [1165]	1118 [1193]	1135 [1225]	1152 [1256]	1169 [1287]	1186 [1318]	1203 [1350]	1221 [1382]	1239 [1415]	1257 [1447]	—	—	—	—	—	—	—	—	—	—
11400 [5379]	962 [931]	977 [957]	991 [985]	1006 [1012]	1021 [1040]	1037 [1068]	1052 [1097]	1068 [1126]	1084 [1155]	1100 [1185]	1116 [1215]	1132 [1246]	1149 [1277]	1166 [1308]	1183 [1340]	1200 [1372]	1217 [1404]	1235 [1437]	1253 [1470]	—	—	—	—	—	—	—	—	—	—	—
11600 [5474]	978 [976]	992 [1003]	1007 [1031]	1022 [1059]	1037 [1088]	1052 [1117]	1067 [1146]	1083 [1176]	1099 [1206]	1115 [1236]	1131 [1267]	1147 [1298]	1164 [1329]	1180 [1384]	1195 [1416]	1212 [1449]	1229 [1482]	1246 [1516]	—	—	—	—	—	—	—	—	—	—	—	—
11800 [5568]	994 [1023]	1008 [1051]	1023 [1079]	1037 [1087]	1052 [1137]	1067 [1167]	1083 [1197]	1098 [1227]	1114 [1257]	1130 [1288]	1146 [1320]	1162 [1351]	1178 [1384]	1195 [1416]	1212 [1449]	1229 [1482]	1246 [1516]	—	—	—	—	—	—	—	—	—	—	—	—	—
12000 [5663]	1010 [1071]	1024 [1100]	1039 [1129]	1053 [1158]	1068 [1188]	1083 [1218]	1098 [1248]	1114 [1279]	1129 [1310]	1145 [1342]	1161 [1374]	1177 [1406]	1193 [1439]	1210 [1472]	1226 [1505]	1243 [1539]	—	—	—	—	—	—	—	—	—	—	—	—	—	—
12200 [5757]	1026 [1121]	1040 [1150]	1055 [1179]	1069 [1209]	1084 [1240]	1099 [1271]	1114 [1302]	1129 [1333]	1145 [1365]	1160 [1397]	1176 [1430]	1192 [1463]	1208 [1496]	1225 [1529]	1241 [1564]	—	—	—	—	—	—	—	—	—	—	—	—	—	—	—
12400 [5851]	1042 [1171]	1056 [1201]	1071 [1232]	1085 [1262]	1100 [1293]	1115 [1324]	1130 [1356]	1145 [1388]	1160 [1421]	1176 [1453]	1191 [1487]	1207 [1520]	1223 [1554]	1240 [1588]	1256 [1623]	—	—	—	—	—	—	—	—	—	—	—	—	—	—	—
12600 [5946]	1059 [1224]	1073 [1254]	1087 [1285]	1101 [1316]	1116 [1348]	1131 [1380]	1145 [1412]	1161 [1445]	1176 [1478]	1191 [1511]	1207 [1545]	1223 [1579]	1239 [1614]	1255 [1648]	—	—	—	—	—	—	—	—	—	—	—	—	—	—	—	—
12800 [6040]	1076 [1277]	1089 [1308]	1103 [1340]	1118 [1372]	1132 [1404]	1147 [1436]	1162 [1469]	1176 [1503]	1192 [1536]	1207 [1570]	1223 [1605]	1238 [1639]	1254 [1674]	—	—	—	—	—	—	—	—	—	—	—	—	—	—	—	—	—
13000 [6134]	1092 [1332]	1106 [1364]	1120 [1396]	1134 [1429]	1149 [1461]	1163 [1494]	1178 [1528]	1193 [1562]	1208 [1596]	1223 [1631]	1238 [1666]	1254 [1701]	—	—	—	—	—	—	—	—	—	—	—	—	—	—	—	—	—	—
13200 [6229]	1109 [1389]	1123 [1421]	1137 [1454]	1151 [1487]	1165 [1520]	1179 [1554]	1194 [1588]	1209 [1622]	1224 [1657]	1239 [1693]	1254 [1728]	—	—	—	—	—	—	—	—	—	—	—	—	—	—	—	—	—	—	—

NOTE: F-Drive left of the bold line, G-Drive right of bold lines.

Drive Package	F						G						H					
	0	1	2	3	4	5	1	2	3	4	5	6	1	2	3	4	5	6
Motor H.P. [W]	—	—	—	7.5 [5592.7]	—	—	—	—	—	10 [7457.0]	—	—	—	—	—	15 [11185.5]	—	—
Blower Sheave	—	—	—	BK130H	—	—	—	—	—	BK120H	—	—	—	—	—	BK190H	—	—
Motor Sheave	—	—	—	1VP-71	—	—	—	—	—	1VP-75	—	—	—	—	—	1VP71	—	—
Turns Open	—	—	—	3	4	5	—	—	—	1	2	3	—	—	—	1	2	3
RPM	—	—	—	932	—	—	—	—	—	—	—	—	—	—	—	—	—	

- 1. Factory sheave settings are shown in bold type.
- 2. Do not set motor sheave below minimum or maximum turns open shown.
- 3. Re-adjustment of sheave required to achieve rated airflow at AHRI minimum External Static Pressure.
- 4. Drive data shown is for horizontal airflow with dry coil. Add component resistance (below) to duct resistance to determine total External Static Pressure.
- 5. A RPM meter is required.

[] Designates Metric Conversions

COMPONENT AIRFLOW RESISTANCE—27.5 TON [96.7 kW] — DOWNFLOW

CFM [L/s]	Resistance — Inches of Water [kPa]														
	8000 [3775]	8400 [3964]	8800 [4153]	9200 [4341]	9600 [4530]	10000 [4719]	10400 [4908]	10800 [5096]	11200 [5285]	11600 [5474]	12000 [5663]	12400 [5851]	12800 [6040]	13200 [6229]	13600 [6418]
Wet Coil	0.07 [.02]	0.09 [.02]	0.10 [.02]	0.12 [.03]	0.13 [.03]	0.15 [.04]	0.16 [.04]	0.18 [.04]	0.19 [.05]	0.21 [.05]	0.22 [.05]	0.24 [.06]	0.25 [.06]	0.27 [.07]	0.28 [.07]
Downflow	0.12 [.03]	0.14 [.03]	0.16 [.04]	0.19 [.05]	0.22 [.05]	0.25 [.06]	0.29 [.07]	0.33 [.08]	0.37 [.09]	0.42 [.10]	0.46 [.11]	0.51 [.13]	0.57 [.14]	0.62 [.15]	0.68 [.17]
Downflow Economizer RA Damper Open	0.22 [.05]	0.24 [.06]	0.26 [.06]	0.28 [.07]	0.30 [.07]	0.32 [.08]	0.34 [.08]	0.37 [.09]	0.39 [.10]	0.41 [.10]	0.44 [.11]	0.46 [.11]	0.49 [.12]	0.52 [.13]	0.54 [.13]
Horizontal Economizer RA Damper Open	0.09 [.02]	0.10 [.03]	0.11 [.03]	0.12 [.03]	0.13 [.03]	0.14 [.03]	0.15 [.04]	0.16 [.04]	0.17 [.04]	0.18 [.04]	0.19 [.05]	0.20 [.05]	0.21 [.05]	0.22 [.05]	0.23 [.06]
Concentric Grill RXRN-AD88 & Transition RXMC-CL09	0.17 [.04]	0.23 [.06]	0.30 [.07]	0.36 [.09]	0.43 [.11]	0.50 [.12]	0.56 [.14]	0.63 [.16]	0.69 [.17]	0.76 [.19]	0.82 [.20]	0.89 [.22]	0.96 [.24]	1.02 [.25]	1.09 [.27]

AIRFLOW CORRECTION FACTORS—27.5 TON [96.7 kW] — DOWNFLOW

CFM [L/s]	8000 [3775]	8400 [3964]	8800 [4153]	9200 [4341]	9600 [4530]	10000 [4719]	10400 [4908]	10800 [5096]	11200 [5285]	11600 [5474]	12000 [5663]	12400 [5851]	12800 [6040]	13200 [6229]	13600 [6418]
Total MBH	0.97	0.98	0.99	1.00	1.00	1.01	1.02	1.03	1.03	1.04	1.05	1.06	1.07	1.07	1.08
Sensible MBH	0.93	0.95	0.97	0.99	1.01	1.03	1.05	1.07	1.09	1.11	1.13	1.15	1.17	1.19	1.21
Power kW	0.99	0.99	0.99	1.00	1.00	1.01	1.01	1.01	1.02	1.02	1.02	1.03	1.03	1.04	1.04

NOTE: Multiply correction factor times gross performance data — resulting sensible capacity cannot exceed total capacity.

[] Designates Metric Conversions

AIRFLOW PERFORMANCE — 27.5 TON [96.7 kW] — 60 Hz — SIDEFLOW

Air Flow CFM [L/s]	Model RGEH4U360A Voltage 208/230, 460, 575 — 3 phase 60 Hz																			
	External Static Pressure—Inches of Water [kPa]																			
	0.1 [.02]	0.2 [.05]	0.3 [.07]	0.4 [.10]	0.5 [.12]	0.6 [.15]	0.7 [.17]	0.8 [.20]	0.9 [.22]	1.0 [.25]	1.1 [.27]	1.2 [.30]	1.3 [.32]	1.4 [.35]	1.5 [.37]	1.6 [.40]	1.7 [.42]	1.8 [.45]	1.9 [.47]	2.0 [.50]
8000 [3775]																				
8200 [3869]																				
8400 [3964]																				
8600 [4058]																				
8800 [4153]																				
9000 [4247]																				
9200 [4341]																				
9400 [4436]																				
9600 [4530]																				
9800 [4624]																				
10000 [4719]																				
10200 [4813]																				
10400 [4908]																				
10600 [5002]																				
10800 [5096]																				
11000 [5191]																				
11200 [5285]																				
11400 [5379]																				
11600 [5474]																				
11800 [5568]																				
12000 [5663]																				
12200 [5757]																				
12400 [5851]																				
12600 [5946]																				
12800 [6040]																				
13000 [6134]																				
13200 [6229]																				
13400 [6323]																				

NOTE: F-Drive left of the bold line, G-Drive right of bold lines.

Drive Package	F										G										H											
	0	1	2	3	4	5	6	7	8	9	0	1	2	3	4	5	6	7	8	9	0	1	2	3	4	5	6	7	8	9		
Motor H.P. [W]																																15 [11185.5]
Blower Sheave																																BK190H
Motor Sheave																																1VP71
Turns Open																																1
RPM																																1165

- NOTES: 1. Factory sheave settings are shown in bold type.
 2. Do not set motor sheave below minimum or maximum turns open shown.
 3. Re-adjustment of sheave required to achieve rated airflow at AHRI minimum External Static Pressure.
 4. Drive data shown is for horizontal airflow with dry coil. Add component resistance (below) to duct resistance to determine total External Static Pressure.
 5. A RPM meter is required.

[] Designates Metric Conversions

COMPONENT AIRFLOW RESISTANCE—27.5 TON [96.7 kW] — SIDEFLOW

CFM [L/s]	Resistance — Inches of Water [kPa]														
	8000 [3775]	8400 [3964]	8800 [4153]	9200 [4341]	9600 [4530]	10000 [4719]	10400 [4908]	10800 [5096]	11200 [5285]	11600 [5474]	12000 [5663]	12400 [5851]	12800 [6040]	13200 [6229]	13600 [6418]
Wet Coil	0.07 [.02]	0.09 [.02]	0.10 [.02]	0.12 [.03]	0.13 [.03]	0.15 [.04]	0.16 [.04]	0.18 [.04]	0.19 [.05]	0.21 [.05]	0.22 [.05]	0.24 [.06]	0.25 [.06]	0.27 [.07]	0.28 [.07]
Downflow	0.12 [.03]	0.14 [.03]	0.16 [.04]	0.19 [.05]	0.22 [.05]	0.25 [.06]	0.29 [.07]	0.33 [.08]	0.37 [.09]	0.42 [.10]	0.46 [.11]	0.51 [.13]	0.57 [.14]	0.62 [.15]	0.68 [.17]
Downflow Economizer RA Damper Open	0.22 [.05]	0.24 [.06]	0.26 [.06]	0.28 [.07]	0.30 [.07]	0.32 [.08]	0.34 [.08]	0.37 [.09]	0.39 [.10]	0.41 [.10]	0.44 [.11]	0.46 [.11]	0.49 [.12]	0.52 [.13]	0.54 [.13]
Horizontal Economizer RA Damper Open	0.09 [.02]	0.10 [.03]	0.11 [.03]	0.12 [.03]	0.13 [.03]	0.14 [.03]	0.15 [.04]	0.16 [.04]	0.17 [.04]	0.18 [.04]	0.19 [.05]	0.20 [.05]	0.21 [.05]	0.22 [.05]	0.23 [.06]
Concentric Grill RXRN-AD88 & Transition RXMC-CL09	0.17 [.04]	0.23 [.06]	0.30 [.07]	0.36 [.09]	0.43 [.11]	0.50 [.12]	0.56 [.14]	0.63 [.16]	0.69 [.17]	0.76 [.19]	0.82 [.20]	0.89 [.22]	0.96 [.24]	1.02 [.25]	1.09 [.27]

AIRFLOW CORRECTION FACTORS—27.5 TON [96.7 kW] — SIDEFLOW

CFM [L/s]	8000 [3775]	8400 [3964]	8800 [4153]	9200 [4341]	9600 [4530]	10000 [4719]	10400 [4908]	10800 [5096]	11200 [5285]	11600 [5474]	12000 [5663]	12400 [5851]	12800 [6040]	13200 [6229]	13600 [6418]
Total MBH	0.97	0.98	0.99	1.00	1.00	1.01	1.02	1.03	1.03	1.04	1.05	1.06	1.07	1.07	1.08
Sensible MBH	0.93	0.95	0.97	0.99	1.01	1.03	1.05	1.07	1.09	1.11	1.13	1.15	1.17	1.19	1.21
Power kW	0.99	0.99	0.99	1.00	1.00	1.01	1.01	1.01	1.02	1.02	1.02	1.03	1.03	1.04	1.04

NOTE: Multiply correction factor times gross performance data — resulting sensible capacity cannot exceed total capacity.

[] Designates Metric Conversions

ELECTRICAL DATA - WITHOUT POWERED EXHAUST - RGEH5U SERIES						
		360ACF	360ACG	360ACH	360ADF	360ADG
Unit Information	Unit Operating Voltage Range	187-253	187-253	187-253	414-506	414-506
	Volts	208/230	208/230	208/230	460	460
	Phase	3	3	3	3	3
	Hz	60	60	60	60	60
	Minimum Circuit Ampacity	163/163	169/169	181/181	72	75
	Minimum Overcurrent Protection Device Size	200/200	200/200	200/200	80	90
	Maximum Overcurrent Protection Device Size	200/200	225/225	225/225	90	100
Compressor Motor	No.	2	2	2	2	2
	Volts	200/230	200/230	200/230	460	460
	Phase	3	3	3	3	3
	RPM	3500	3500	3500	3500	3500
	HP, Compressor 1	15	15	15	15	15
	Amps (RLA), Comp. 1	57.8	57.8	57.8	25	25
	Amps (LRA), Comp. 1	386.3	386.3	386.3	182	182
	HP, Compressor 2	10	10	10	10	10
	Amps (RLA), Comp. 2	43.7	43.7	43.7	16.5	16.5
	Amps (LRA), Comp. 2	240	240	240	140	140
Condenser Motor	No.	6	6	6	6	6
	Volts	208/230	208/230	208/230	460	460
	Phase	1	1	1	1	1
	HP	3/4	3/4	3/4	3/4	3/4
	Amps (FLA, each)	4.2	4.2	4.2	2.3	2.3
	Amps (LRA, each)	10.1	10.1	10.1	4.9	4.9
Evaporator Fan	No.	1	1	1	1	1
	Volts	208/230	208/230	208/230	460	460
	Phase	3	3	3	3	3
	HP	7 1/2	10	15	7 1/2	10
	Amps (FLA, each)	21	27	39.5	9.6	12.5
	Amps (LRA, each)	127	152	210	63.5	76

ELECTRICAL DATA - WITHOUT POWERED EXHAUST - RGEH5U SERIES

		360ADH	360AYF	360AYG	360AYH
Unit Information	Unit Operating Voltage Range	414-506	517-633	517-633	517-633
	Volts	460	575	575	575
	Phase	3	3	3	3
	Hz	60	60	60	60
	Minimum Circuit Ampacity	80	50	52	56
	Minimum Overcurrent Protection Device Size	90	60	60	70
	Maximum Overcurrent Protection Device Size	100	60	70	70
Compressor Motor	No.	2	2	2	2
	Volts	460	575	575	575
	Phase	3	3	3	3
	RPM	3500	3500	3500	3500
	HP, Compressor 1	15	15	15	15
	Amps (RLA), Comp. 1	25	18.8	18.8	18.8
	Amps (LRA), Comp. 1	182	131	131	131
	HP, Compressor 2	10	10	10	10
	Amps (RLA), Comp. 2	16.5	12.9	12.9	12.9
	Amps (LRA), Comp. 2	140	107.6	107.6	107.6
Condenser Motor	No.	6	6	6	6
	Volts	460	575	575	575
	Phase	1	1	1	1
	HP	3/4	3/4	3/4	3/4
	Amps (FLA, each)	2.3	1.2	1.2	1.2
	Amps (LRA, each)	4.9	3.4	3.4	3.4
Evaporator Fan	No.	1	1	1	1
	Volts	460	575	575	575
	Phase	3	3	3	3
	HP	15	7 1/2	10	15
	Amps (FLA, each)	18	7.7	10	13.8
	Amps (LRA, each)	105	50.8	60.8	93.6

ELECTRICAL DATA - WITH POWERED EXHAUST - RGEH5U SERIES						
		360ACF	360ACG	360ACH	360ADF	360ADG
Unit Information	Unit Operating Voltage Range	187-253	187-253	187-253	414-506	414-506
	Volts	208/230	208/230	208/230	460	460
	Phase	3	3	3	3	3
	Hz	60	60	60	60	60
	Minimum Circuit Ampacity	173/173	179/179	191/191	76	79
	Minimum Overcurrent Protection Device Size	200/200	200/200	225/225	90	90
	Maximum Overcurrent Protection Device Size	225/225	225/225	225/225	100	100
Compressor Motor	No.	2	2	2	2	2
	Volts	200/230	200/230	200/230	460	460
	Phase	3	3	3	3	3
	RPM	3500	3500	3500	3500	3500
	HP, Compressor 1	15	15	15	15	15
	Amps (RLA), Comp. 1	57.8	57.8	57.8	25	25
	Amps (LRA), Comp. 1	386.3	386.3	386.3	182	182
	HP, Compressor 2	10	10	10	10	10
	Amps (RLA), Comp. 2	43.7	43.7	43.7	16.5	16.5
	Amps (LRA), Comp. 2	240	240	240	140	140
Condenser Motor	No.	6	6	6	6	6
	Volts	208/230	208/230	208/230	460	460
	Phase	1	1	1	1	1
	HP	3/4	3/4	3/4	3/4	3/4
	Amps (FLA, each)	4.2	4.2	4.2	2.3	2.3
	Amps (LRA, each)	10.1	10.1	10.1	4.9	4.9
Evaporator Fan	No.	1	1	1	1	1
	Volts	208/230	208/230	208/230	460	460
	Phase	3	3	3	3	3
	HP	7 1/2	10	15	7 1/2	10
	Amps (FLA, each)	21	27	39.5	9.6	12.5
	Amps (LRA, each)	127	152	210	63.5	76

ELECTRICAL DATA - WITH POWERED EXHAUST - RGEH5U SERIES

		360ADH	360AYF	360AYG	360AYH
Unit Information	Unit Operating Voltage Range	414-506	517-633	517-633	517-633
	Volts	460	575	575	575
	Phase	3	3	3	3
	Hz	60	60	60	60
	Minimum Circuit Ampacity	84	53	55	59
	Minimum Overcurrent Protection Device Size	100	60	60	70
	Maximum Overcurrent Protection Device Size	100	70	70	70
Compressor Motor	No.	2	2	2	2
	Volts	460	575	575	575
	Phase	3	3	3	3
	RPM	3500	3500	3500	3500
	HP, Compressor 1	15	15	15	15
	Amps (RLA), Comp. 1	25	18.8	18.8	18.8
	Amps (LRA), Comp. 1	182	131	131	131
	HP, Compressor 2	10	10	10	10
	Amps (RLA), Comp. 2	16.5	12.9	12.9	12.9
Amps (LRA), Comp. 2	140	107.6	107.6	107.6	
Condenser Motor	No.	6	6	6	6
	Volts	460	575	575	575
	Phase	1	1	1	1
	HP	3/4	3/4	3/4	3/4
	Amps (FLA, each)	2.3	1.2	1.2	1.2
	Amps (LRA, each)	4.9	3.4	3.4	3.4
Evaporator Fan	No.	1	1	1	1
	Volts	460	575	575	575
	Phase	3	3	3	3
	HP	15	7 1/2	10	15
	Amps (FLA, each)	18	7.7	10	13.8
	Amps (LRA, each)	105	50.8	60.8	93.6

MANUAL MOTOR STARTER AMP SETPOINT

	Motor Part No.	51-102826-10	51-102826-11	51-107478-01	51-107478-02
	Motor HP	10	10	15	15
Motor Nameplate Amps	208V	27.0	—	39.5	—
	230V	25.0	—	36.0	—
	460V	12.5	—	18.0	—
	575V	—	10.0	—	14.4
Motor SF amps	208V	31.1	—	45.4	—
	230V	28.8	—	41.4	—
	460V	14.4	—	20.7	—
	575V	—	11.5	—	16.6
Manual Motor Starter Amp Range	208/230V	25.0-32.0	—	40.0-54.0	—
	460V	10.0-16.0	—	20.0-25.0	—
	575V	—	8.0-12.0	—	16.0-20.0
Friedrich Part No.	208/230V	42-107877-05	—	42-107877-06	—
	460V	42-107877-02	—	42-107877-04	—
	575V	—	42-107877-01	—	42-107877-03
Manual Motor Starter Amp Setpoint	208V	32.0*	—	47.0*	—
	230V	30.0	—	43.0	—
	460V	15.0	—	22.0	—
	575V	—	12.0	—	17.0
Friedrich Model No.	208/230V	RGEH5U360ACG RACH5U360ACG	—	RGEH5U360ACH RACH5U360ACH	—
	460V	RGEH5U360ADG RACH5U360ADG	—	RGEH5U360ADH RACH5U360ADH	—
	575V	—	RGEH5U360AYG RACH5U360AYG	—	RGEH5U360AYH RACH5U360AYH

NOTE: Units ship from factory set for 230 volt operation. Setpoint must be adjusted for 208 volt operation.

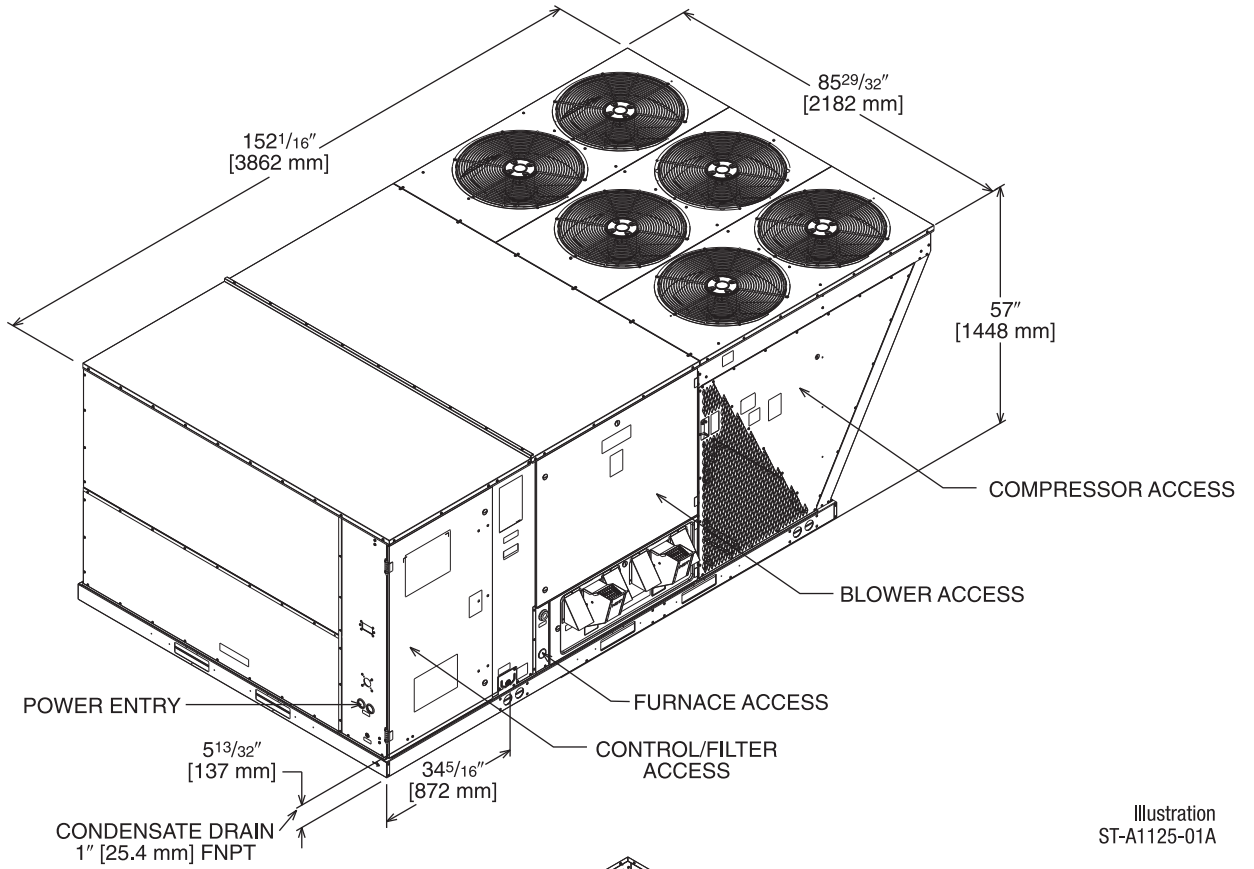
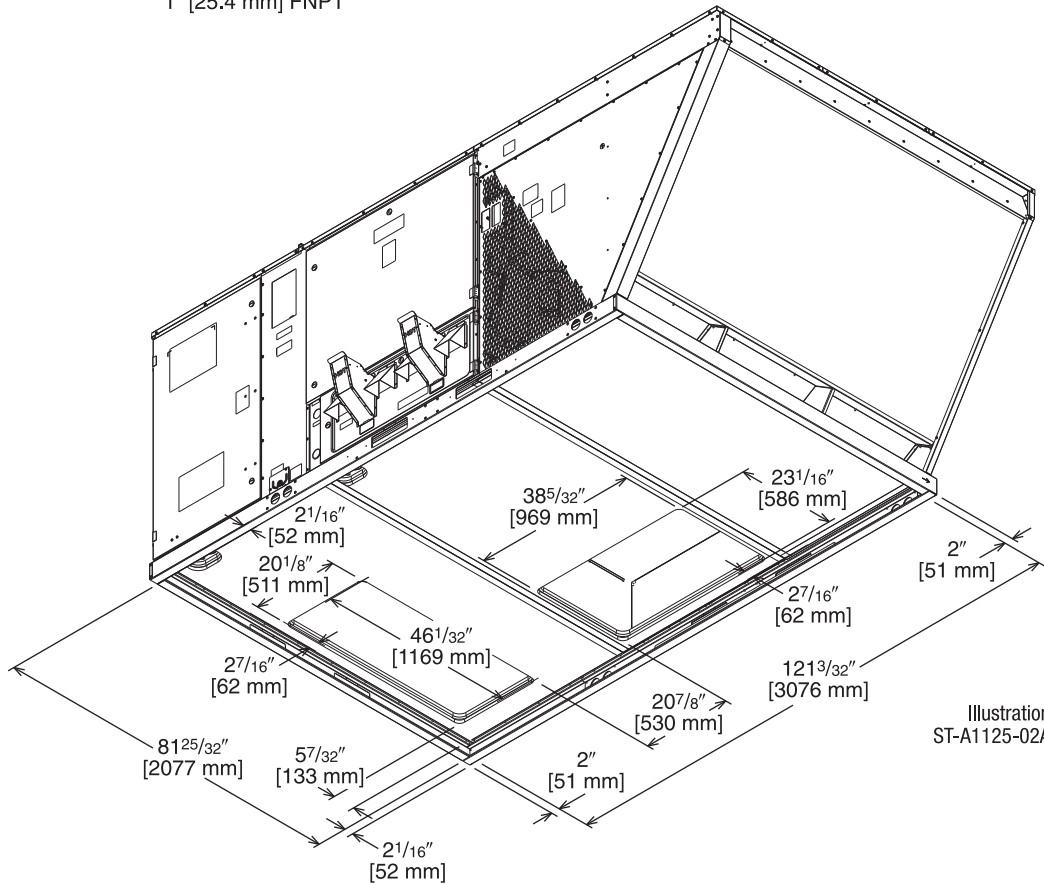

Illustration
ST-A1125-01A



BOTTOM VIEW

Illustration
ST-A1125-02A

[] Designates Metric Conversions

SUPPLY AND RETURN DIMENSIONS FOR HORIZONTAL APPLICATIONS

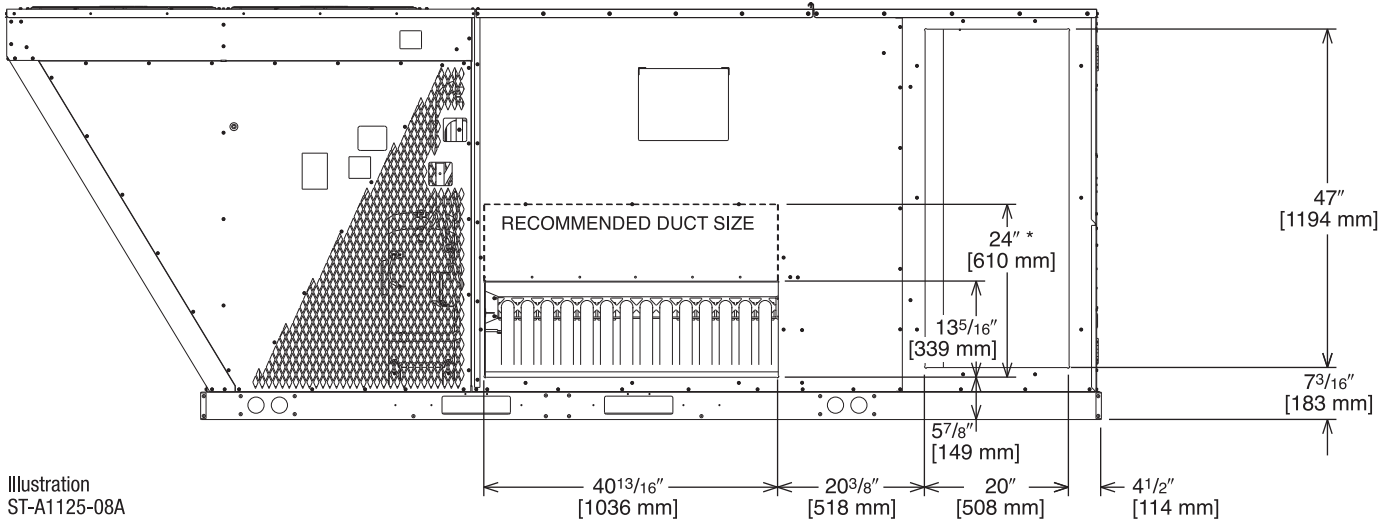

Illustration
ST-A1125-08A

* RECOMMENDED DUCT CONNECTION SIZE

DUCT SIDE VIEW (REAR)

SUPPLY AND RETURN DIMENSIONS FOR DOWNFLOW APPLICATIONS

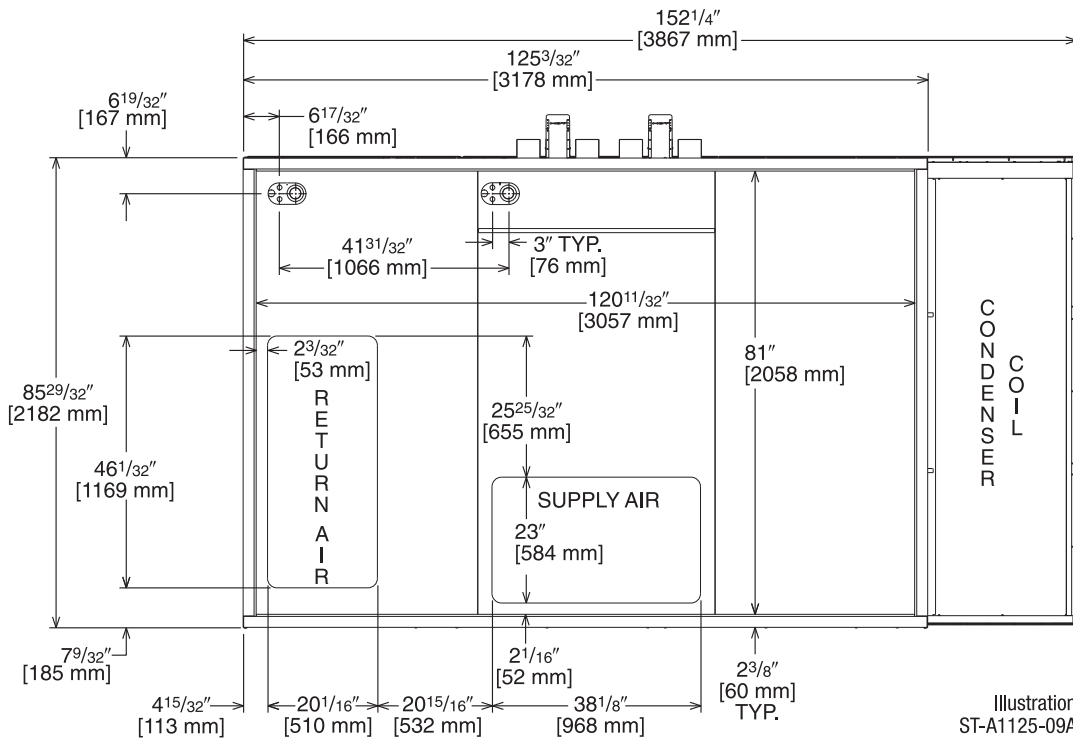

Illustration
ST-A1125-09A

BOTTOM VIEW

[] Designates Metric Conversions

UNIT DIMENSIONS GAS HEAT / ELECTRIC COOLING PACKAGE

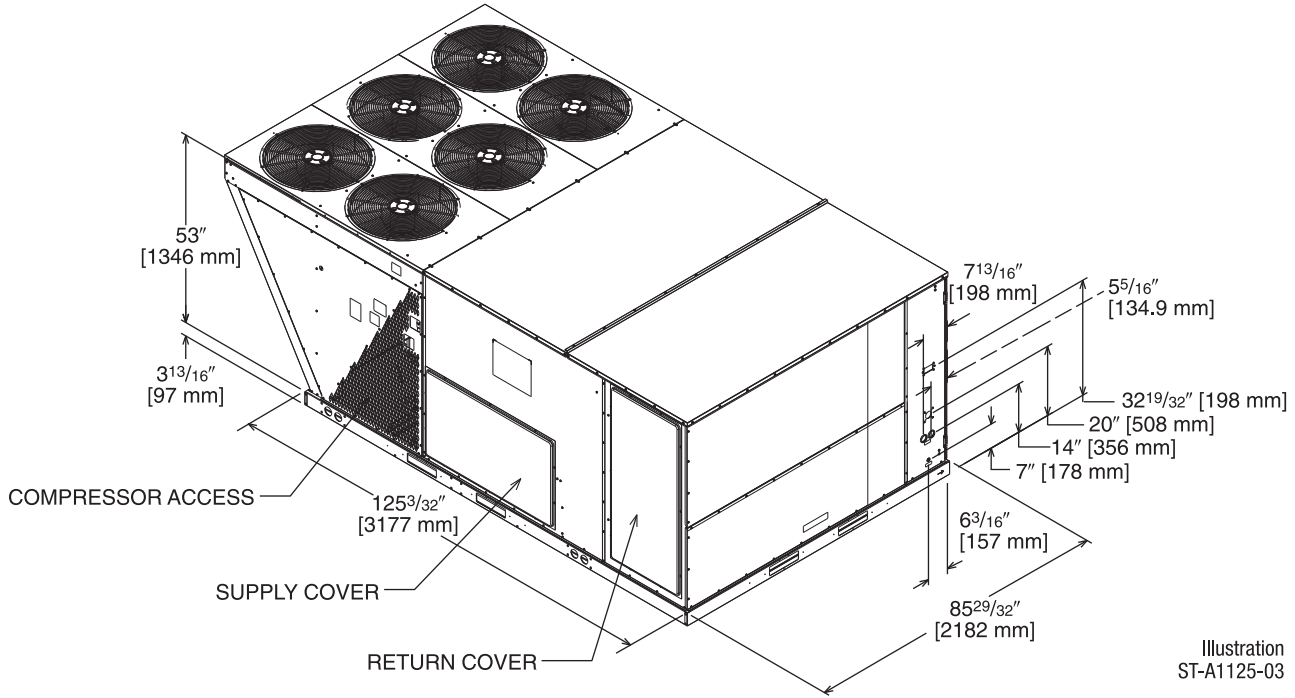
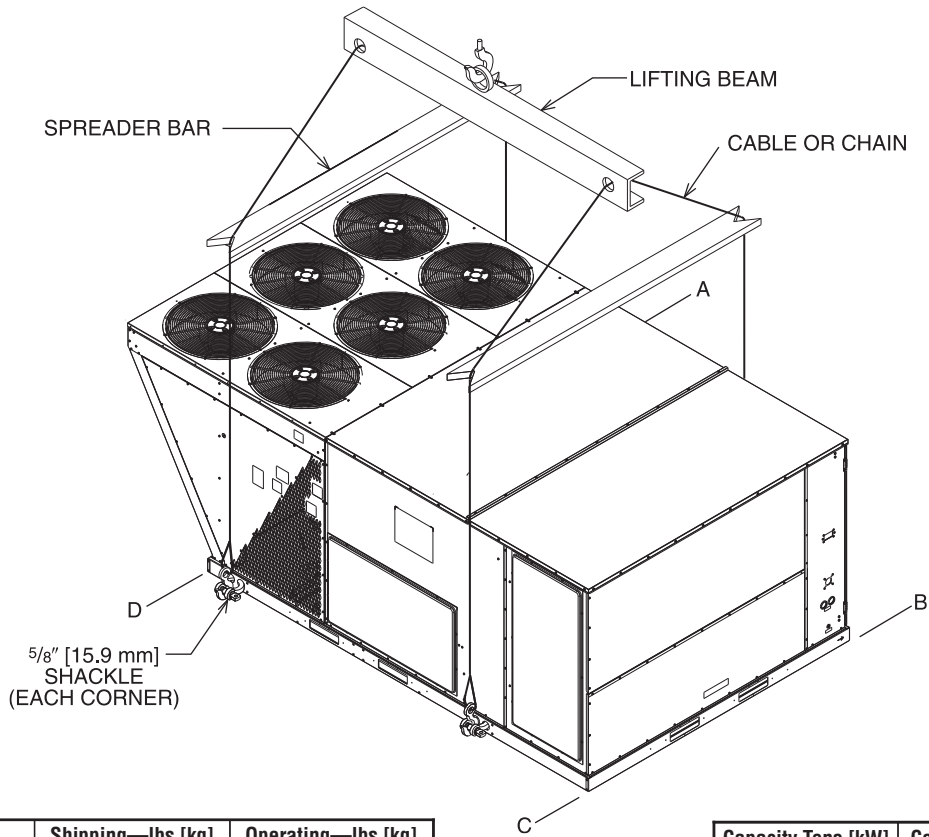

Illustration
ST-A1125-03



WEIGHTS

Accessory	Shipping—lbs [kg]	Operating—lbs [kg]
Economizer—Downflow	155 [70.31]	146 [66.22]
Economizer—Horizontal	165 [74.80]	155 [70.31]
Fresh Air Damper (Manual)	51 [23.13]	40 [18.14]
Fresh Air Damper (Motorized)	46 [20.87]	35 [15.88]
Roof Curb 14"	170 [77.11]	164 [74.39]

Capacity Tons [kW]	Corner Weights by Percentage			
	A	B	C	D
15-25 [52.8-87.9]	32%	27%	16%	24%

Corner weights measured at base of unit.

[] Designates Metric Conversions

SLAB INSTALLATION

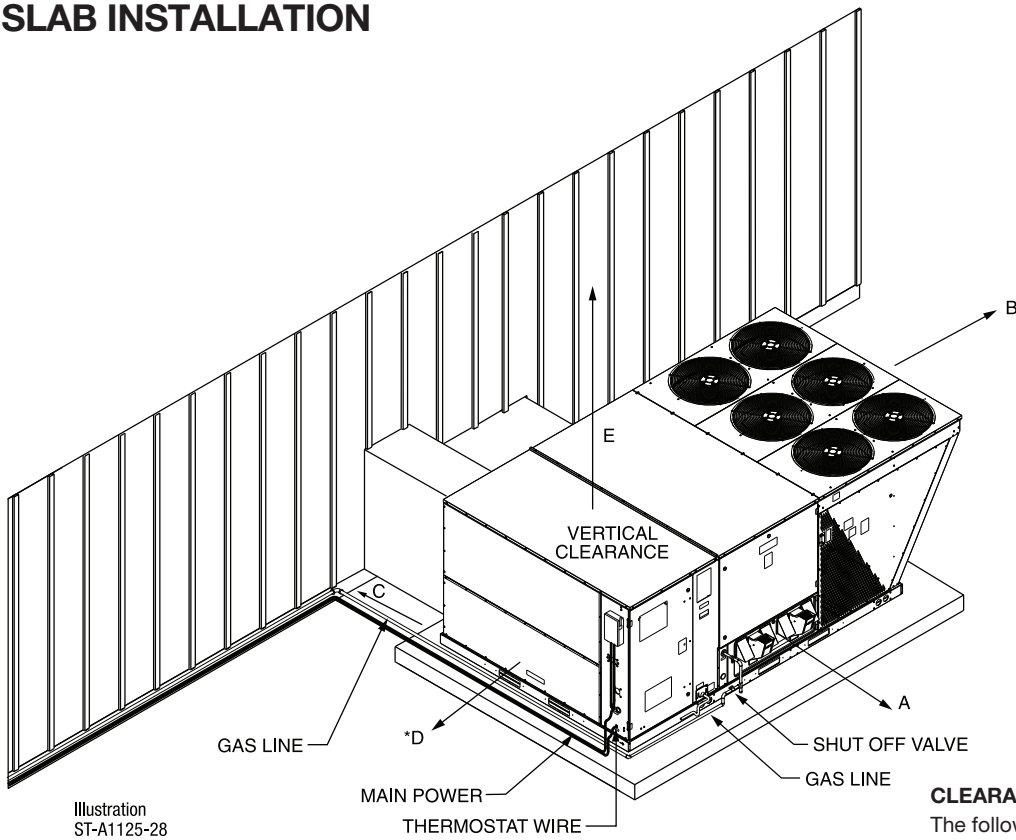

Illustration
ST-A1125-28

CLEARANCES

The following minimum clearances are recommended for proper unit performance and serviceability.

Recommended Clearance In. [mm]	Location
80 [2032]	A - Front
18 [457]	B - Condenser Coil
+18 [457]	+C - Duct Side
*18 [457]	*D - Evaporator End
60 [1524]	E - Above
*Without Economizer. 48" [1219 mm] With Economizer +Without Horizontal Economizer, 42" [1067 mm] with Horizontal Economizer	

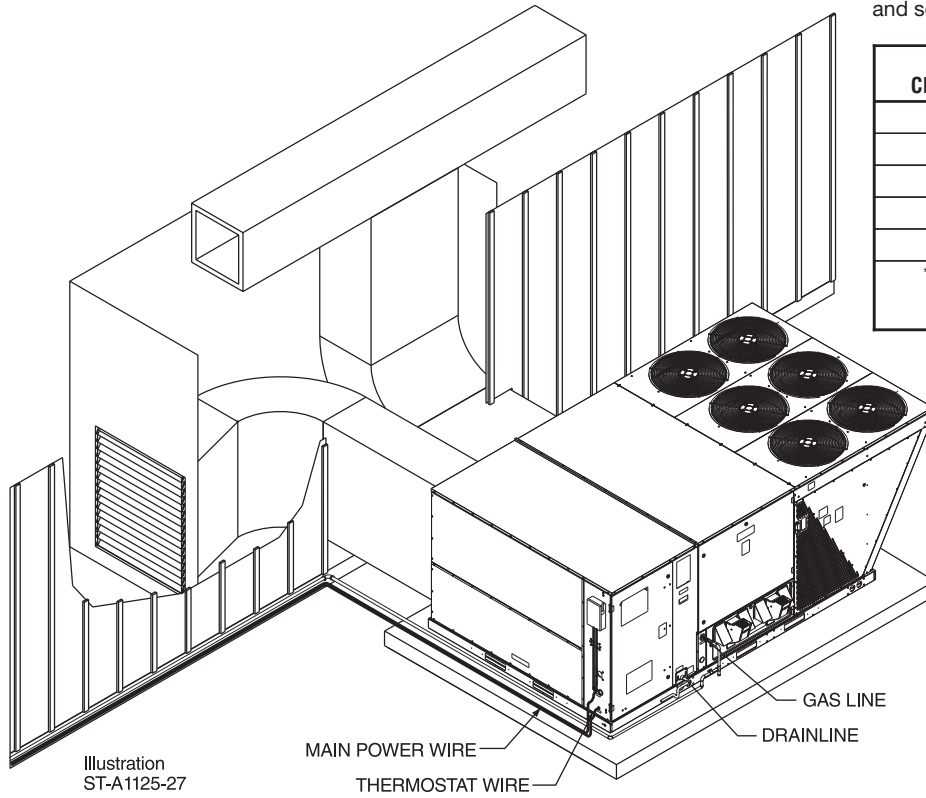

Illustration
ST-A1125-27

[] Designates Metric Conversions

FIELD INSTALLED ACCESSORY EQUIPMENT

Accessory	Model Number	Shipping Weight Lbs. [kg]	Installed Weight Lbs. [kg]	Factory Installation Available?
Economizer w/Single Enthalpy (Downflow)	AXRD-01RMDCM3	324 [149.6]	184 [83.4]	Yes
Economizer w/Single Enthalpy (Horizontal)	AXRD-01RMHCM3	367 [166.4]	258 [117.0]	No
Dual Enthalpy Kit	RXXR-AV01	1 [.5]	.5 [.2]	No
Carbon Dioxide Sensor (Wall Mount)	RXXR-AR02	3 [1.4]	2 [1.0]	No
Power Exhaust (230V)	RXXR-BGF05C	119 [53.9]	59 [26.7]	No
Power Exhaust (460V)	RXXR-BGF05D	119 [53.9]	59 [26.7]	No
Power Exhaust (575V)	RXXR-BGF05Y	119 [53.9]	59 [26.7]	No
Manual Fresh Air Damper	AXRF-KFA1	61 [27.7]	52 [23.6]	No
2-Position Motorized Kit for Fresh Air Damper	RXRF-AW03	42 [19.1]	35 [15.9]	No
Modulating Motor Kit for AXRF-KFA1	RXRF-AW05	45 [20.4]	38 [17.2]	No
Roofcurb, 14"	RXKG-CBH14	184 [83.5]	176 [79.8]	No
Concentric Diffuser (Step-Down, 18" x 36")	RXRN-AD81	310 [140.6]	157 [71.2]	No
Concentric Diffuser (Step-Down, 24" x 48")	RXRN-AD86	367 [166.4]	212 [96.1]	No
Concentric Diffuser (Step-Down, 28" x 60")	RXRN-AD88	410 [186.0]	370 [67.8]	No
Concentric Diffuser (Flush, 18" x 36")	RXRN-AD80	213 [96.6]	115 [52.2]	No
Downflow Transition (Rect. To Rect., 18" x 36")	RXMC-CJ07	81 [36.7]	74 [33.6]	No
Downflow Transition (Rect. To Rect., 24" x 48")	RXMC-CK08	81 [36.7]	74 [33.6]	No
Downflow Transition (Rect. To Rect., 28" x 60")	RXMC-CL09	81 [36.7]	74 [33.6]	No
BACnet Communication Card	RXXR-AY01	1 [0.5]	1 [0.5]	No
LonWorks Communication Card	RXXR-AY02	1 [0.5]	1 [0.5]	No
Room Humidity Sensor	RHC-ZNS4	1 [0.5]	1 [0.5]	No
Room Temperature and Relative Humidity Sensor	RHC-ZNS5	1 [0.5]	1 [0.5]	No
Low-Ambient Control Kit DDC (1 Per Compressor)	RXRZ-C02	3 [1.4]	2 [1.0]	No
Freeze Stat Kit	RXXR-AM05	3 [1.4]	2 [1.0]	Yes
Unwired Convenience Outlet	RXXR-AN01	2 [1.0]	1.5 [.7]	Yes
Hail Guard Louvers	AXRX-AAD01L	55 [24.8]	45 [20.3]	Yes
Return Smoke Detector (Downflow/Vertical)	RXXR-BSH1	7 [3.2]	6 [2.7]	Yes
Return Smoke Detector (Horizontal)	RXXR-BSH2	7 [3.2]	6 [2.7]	Yes
Return/Supply Smoke Detector (Downflow/Vertical)	RXXR-BSH3	10 [4.5]	9 [4.1]	Yes
Return/Supply Smoke Detector (Horizontal)	RXXR-BSH4	10 [4.5]	9 [4.1]	Yes
MERV 8 Filter	RXMF-M08A22520	2 [0.9]	1 [0.45]	Yes
MERV 13 Filter	RXMF-M13A22520	2 [0.9]	1 [0.45]	Yes

[] Designates Metric Conversions

FLUSH MOUNT ROOM TEMPERATURE SENSORS FOR NETWORKED DDC APPLICATIONS



**ROOM TEMPERATURE SENSOR RHC-ZNS1
with TIMED OVERRIDE BUTTON**

10k Ω room temperature sensor transmits room temperature to DDC system. Timed override button allows tenant to change from unoccupied temperature setpoint to occupied temperature setpoint for a preset time.



**ROOM TEMPERATURE SENSOR RHC-ZNS2
with TIMED OVERRIDE BUTTON and STATUS INDICATOR**

10k Ω room temperature sensor transmits room temperature to DDC system. Timed override button allows tenant to change from unoccupied temperature setpoint to occupied temperature setpoint for a preset time. Status Indicator Light transmits ALARM flash code to occupied space.



**ROOM TEMPERATURE SENSOR RHC-ZNS3
with SETPOINT ADJUSTMENT and TIMED OVERRIDE BUTTON**

10k Ω room temperature sensor with setpoint adjustment transmits room temperature to DDC system along with desired occupied room temperature setpoint. Timed override button allows tenant to change from unoccupied temperature setpoint to occupied temperature setpoint for a preset time.

COMMUNICATION CARDS

Field Installed



BACnet® COMMUNICATION CARD RXXR-AY01

The field installed BACnet® Communication Card allows the RTU-C unit controller to communicate with a third party building management system that supports the BACnet Application Specific Controller device profile. The BACnet® Communication Module plugs onto the unit RTU-C controller and allows communication between the RTU-C and the BACnet MSTP network.



LonWorks® COMMUNICATION CARD RXXR-AY02

The field installed LonWorks® Communication Card allows the RTU-C unit controller to communicate with a third party building management system that supports the LonMark Space Comfort Controller (SCC) functional profile or LonMark Discharge Air Controller (DAC) functional profile. The LonMark Communication Module plugs onto the RTU-C controller and allows communication between the RTU-C and a LonWorks Network.

NON-DDC ECONOMIZER FOR DOWNFLOW DUCT INSTALLATION

Use to Select Factory Installed Options Only

AXRD-01RMDCM3—Single Enthalpy (Outdoor) with DDC

RXXR-AR02—Dual Enthalpy Upgrade Kit

RXXR-AR02—Optional Wall-Mounted CO₂ Sensor

- Features **Honeywell** Controls
- Available Factory Installed or Field Accessory
- Gear Driven Direct Drive Actuator
- Fully Modulating (0-100%)
- Low Leakage Dampers
- Slip-In Design for Easy Installation
- Plug-In Polarized 12-pin and 4-pin Electrical Connections
- Pre-Configured—No Field Adjustments Necessary
- Standard Barometric Relief Damper
- Single Enthalpy with Dual Enthalpy Upgrade Kit Available
- CO₂ Input Sensor Available
- Field Assembled Hood Ships with Economizer
- Economizer Ships Complete for Downflow Duct Application
- Optional Remote Minimum Position Potentiometer (270 ohm) (Honeywell #S963B1136) is available from Prostock
- Field Installed Power Exhaust Available

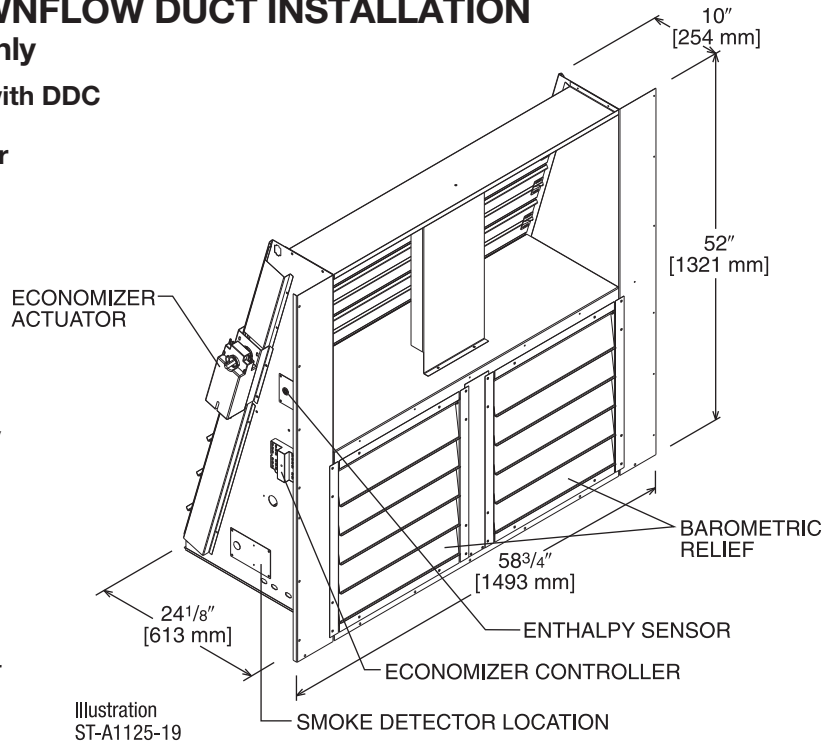

TOLERANCE ± .125

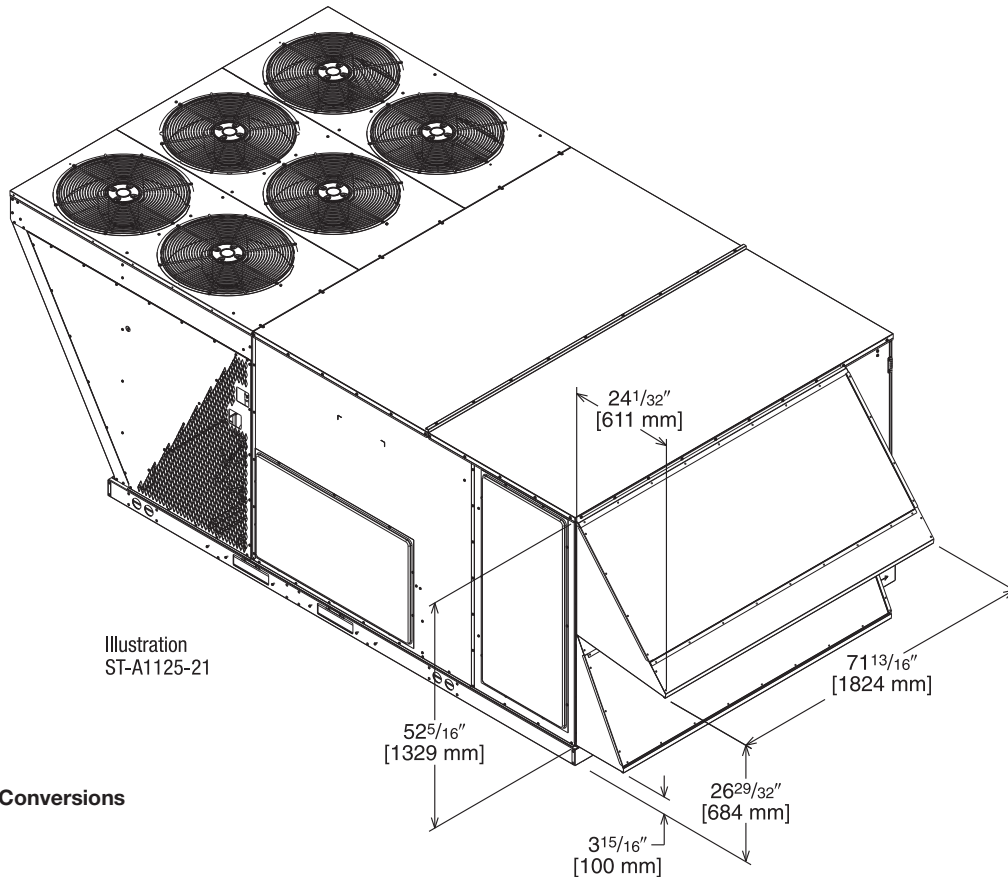

[] Designates Metric Conversions

NON-DDC ECONOMIZER FOR HORIZONTAL DUCT INSTALLATION

Field Installed Only

AXRD-01RMHCM3—Single Enthalpy (Outdoor) with DDC
RXXR-AV04—Dual Enthalpy Upgrade Kit
RXXR-AR02—Wall-mounted CO₂ Sensor

- Features **Honeywell** Controls
- Available as a Field Installed Accessory Only
- Gear Driven Direct Drive Actuator
- Fully Modulating (0-100%)
- Low Leakage Dampers
- Slip-In Design for Easy Installation
- Plug-In Polarized 12-pin and 4-pin Electrical Connections
- Pre-Configured—No Field Adjustments Necessary
- Standard Barometric Relief Damper
- Single Enthalpy with Dual Enthalpy Upgrade Kit Available
- CO₂ Input Sensor Available
- Field Assembled Hood Ships with Economizer
- Economizer Ships Complete for Horizontal Duct Application
- Optional Remote Minimum Position Potentiometer (270 ohm) (Honeywell #S963B1136) is available from Prostock
- Field Installed Power Exhaust Available

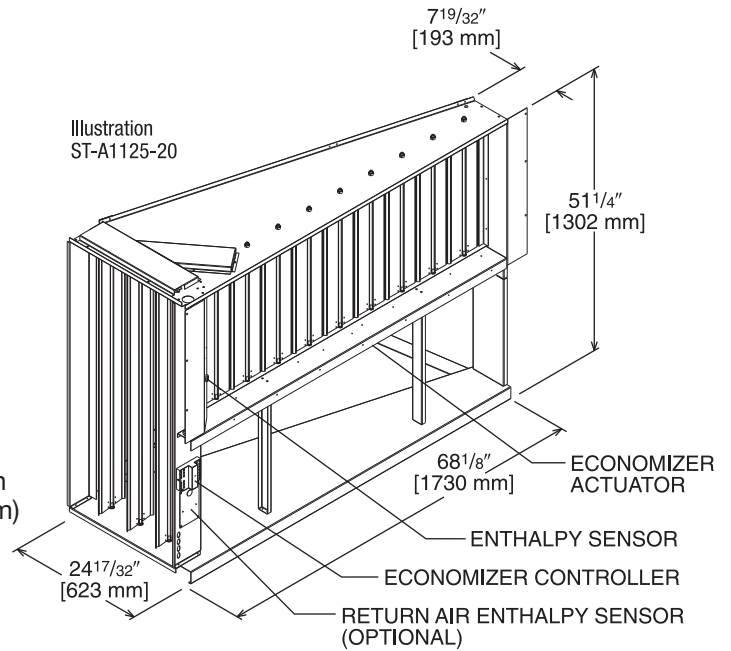

TOLERANCE $\pm .125$

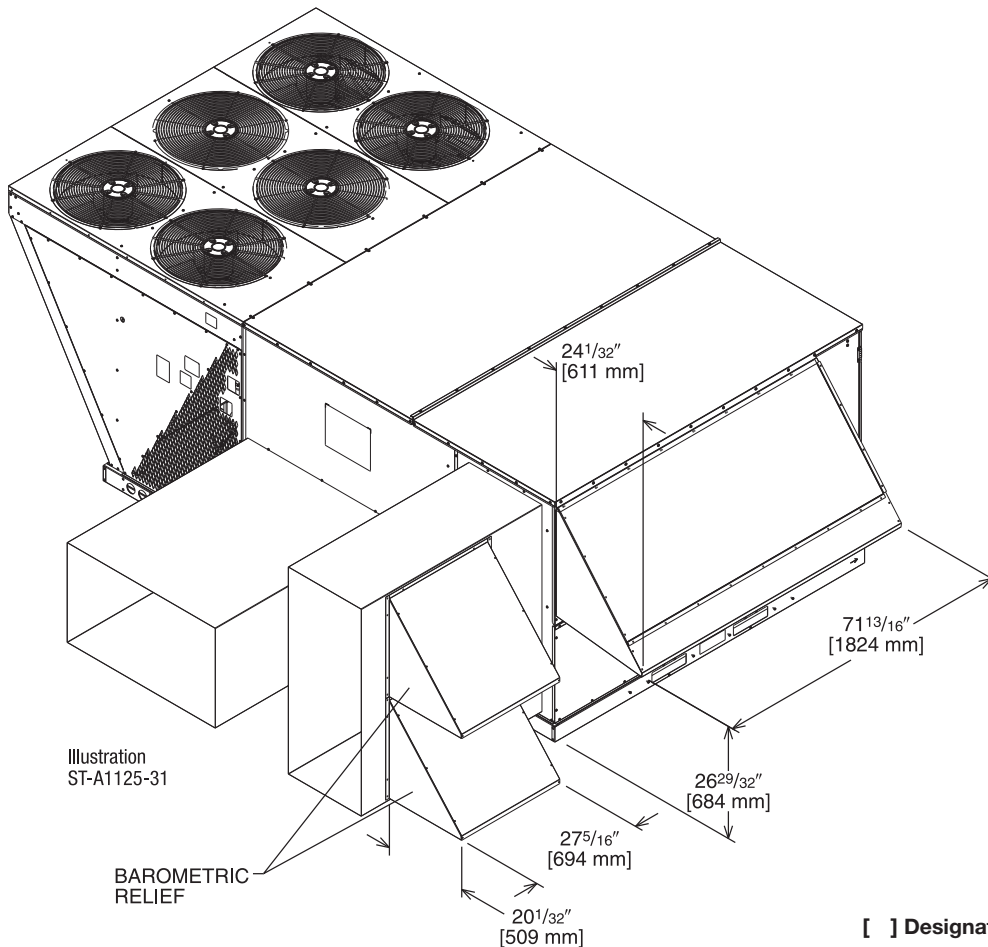

[] Designates Metric Conversions

POWER EXHAUST KIT

RXRX-BGF05 (C, D, or Y*)

*Voltage Code

VERTICAL AIRFLOW

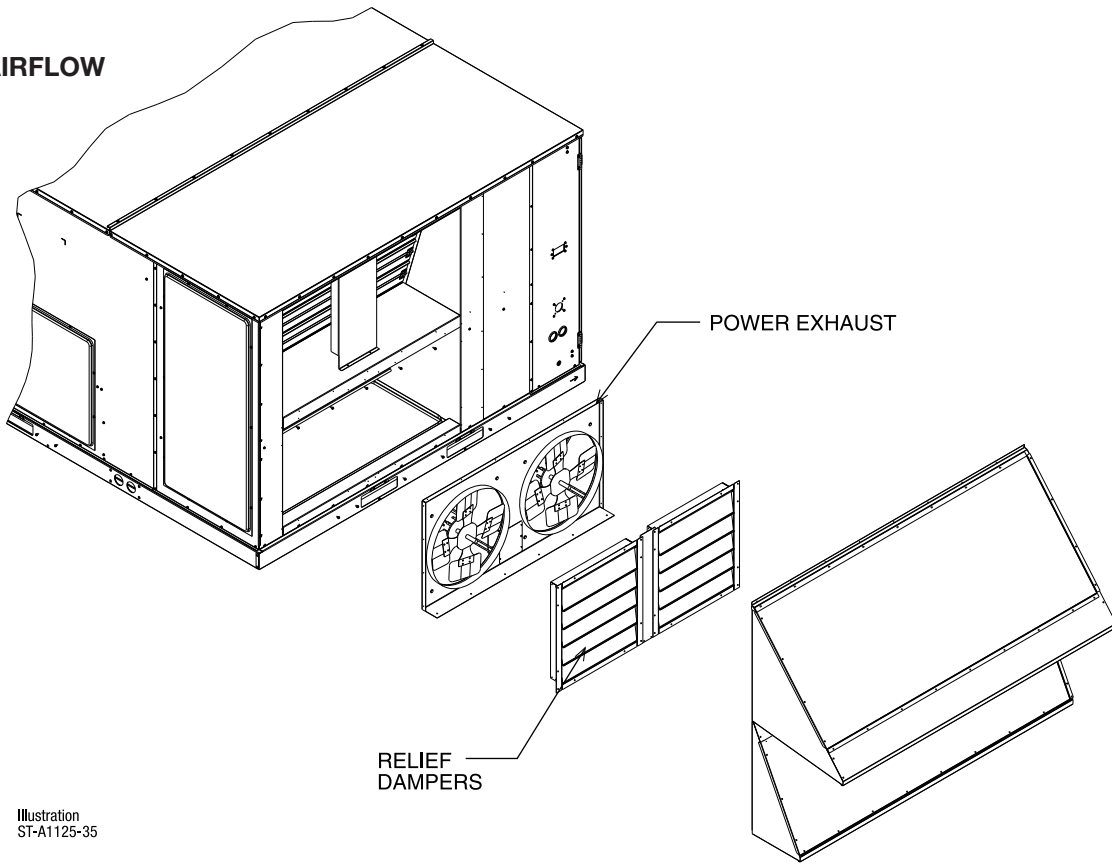

Illustration
ST-A1125-35

Model No.	No. of Fans	Volts	Phase	HP (ea.)	Low Speed		High Speed ①		FLA (ea.)	LRA (ea.)
					CFM [L/s] ②	RPM	CFM [L/s] ②	RPM		
RXRX-BGF05C	2	208-230	1	0.75	4100 [1935]	850	5200 [2454]	1050	5	4.97
RXRX-BGF05D	2	460	1	0.75	4100 [1935]	850	5200 [2454]	1050	2.2	3.4
RXRX-BGF05Y	2	575	1	0.75	4100 [1935]	850	5200 [2454]	1050	1.5	2.84

NOTES: ① Power exhaust is factory set on high speed motor tap.

② CFM is per fan at 0" w.c. external static pressure.

[] Designates Metric Conversions

FRESH AIR DAMPER

MOTORIZED DAMPER KIT

RXR-**AW03**

(Motor Kit for AXRF-KFA1)

RXR-**AW05**

(Modulating Motor Kit with position feedback for AXRF-KFA1)

- Features **Honeywell** Controls
- Gear Driven Direct Drive Actuator
- Fully Modulating (0-100%)
- Low Leakage Dampers
- Slip-In Design for Easy Installation
- Plug-In Polarized 12-pin and 4-pin Electrical Connections
- Pre-Configured—No Field Adjustments Necessary
- Addition of Dual Enthalpy Upgrade Kit allows limited economizer function
- CO₂ Sensor Input Available for Demand Control Ventilation (DCV)
- Optional Remote Minimum Position Potentiometer (270 ohm) (Honeywell #S963B1136) is available from Prostock
- All fresh air damper functions can be viewed at the RTU-C unit controller display

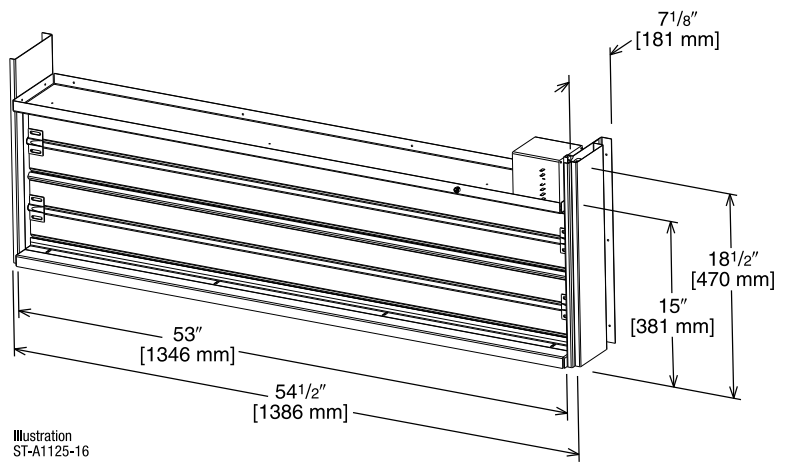

Illustration
ST-A1125-16

AXRF-KFA1 (Manual)

RXR-**AW03** (Motorized damper kit for manual fresh air damper)

RXR-**AW05** (Modulating damper kit with position feedback for AXRF-KFA1)

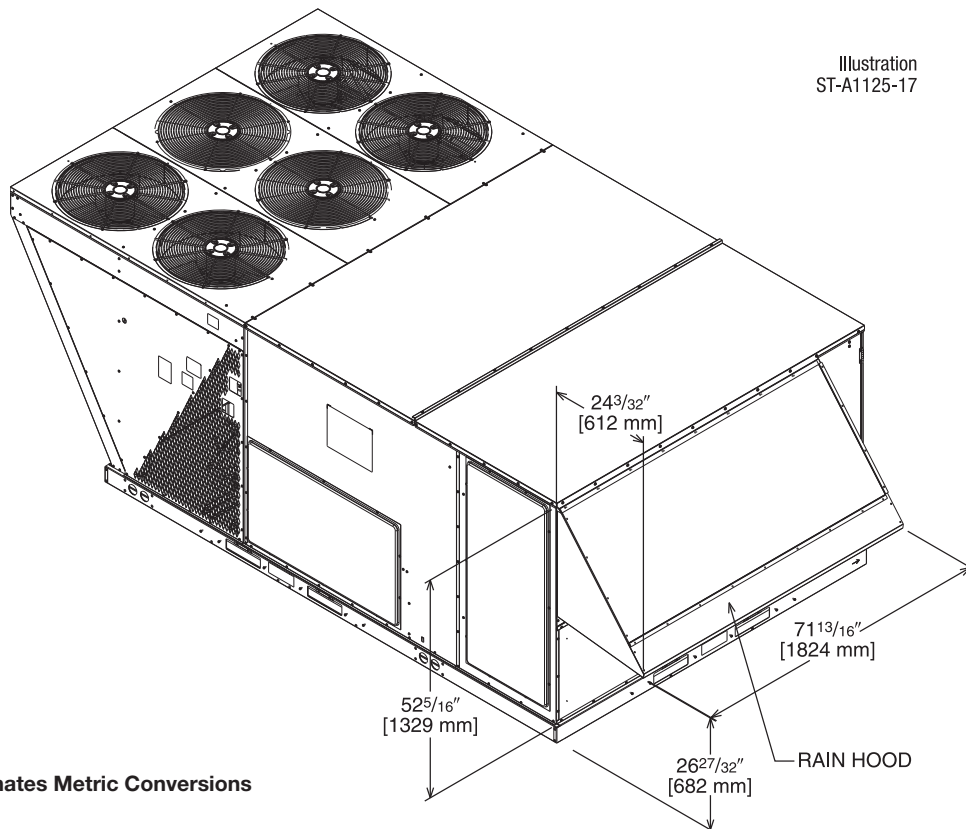

Illustration
ST-A1125-17

[] Designates Metric Conversions

Illustration
ST-A1125-17

ROOFCURBS (Full Perimeter)

- One available height (14" [356 mm]).
- Quick assembly corners for simple and fast assembly.
- 1" [25.4 mm] x 4" [102 mm] Nailers provided.
- Insulating panels not required because of insulated outdoor base pan.
- Sealing gasket (28" [711 mm]) provided with Roofcurb.
- Packaged for easy field assembly.

TYPICAL INSTALLATION

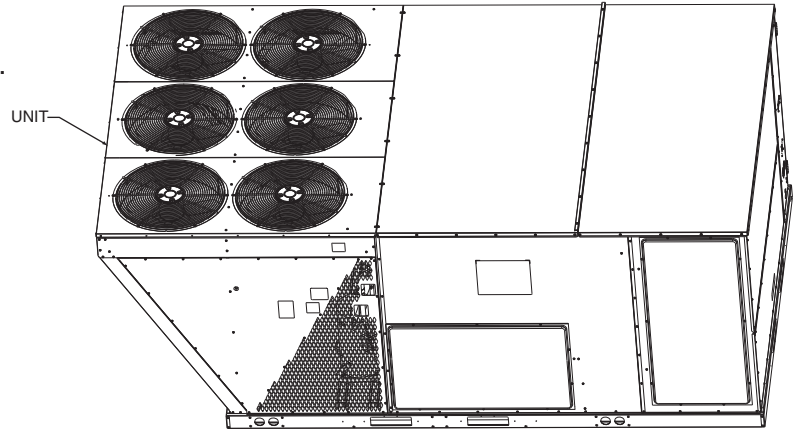

ROOFCURB ASSEMBLY

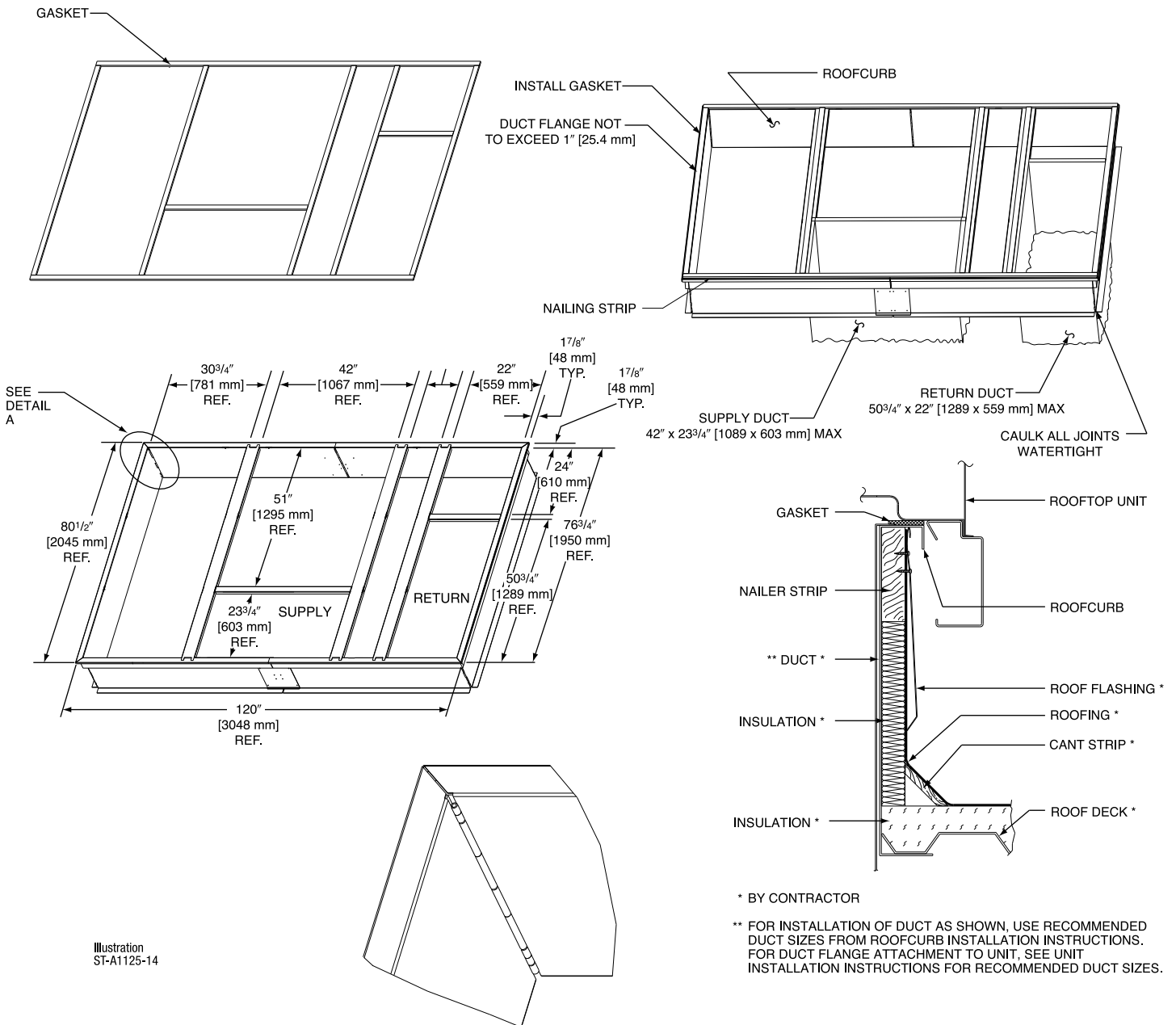
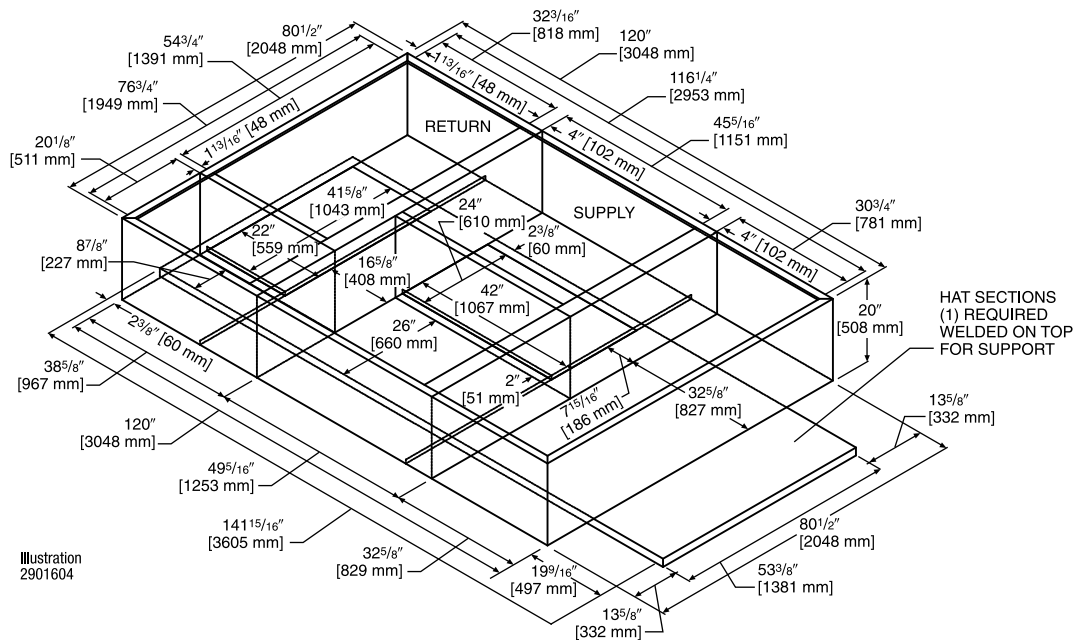
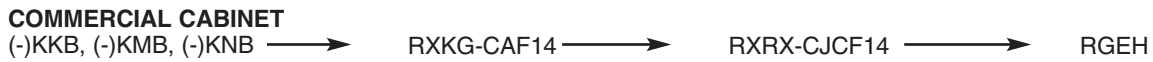
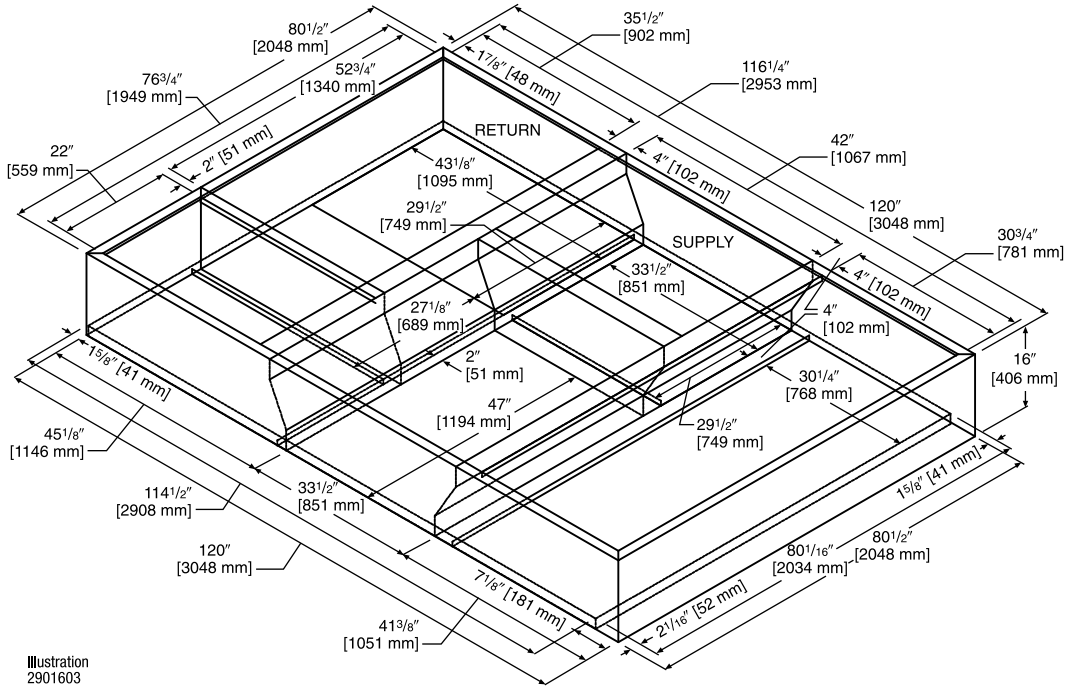
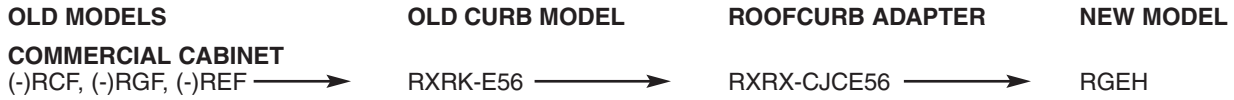

Illustration
ST-A1125-14

DETAIL A

[] Designates Metric Conversions

ROOFCURB ADAPTER



[] Designates Metric Conversions

CONCENTRIC DIFFUSER APPLICATION

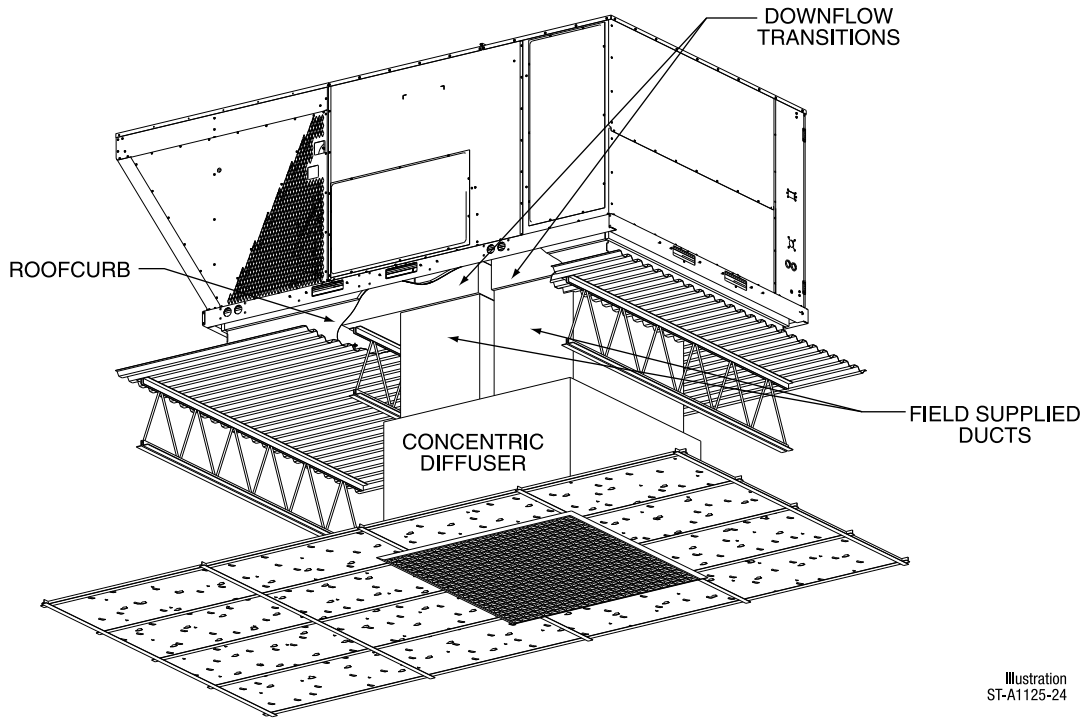
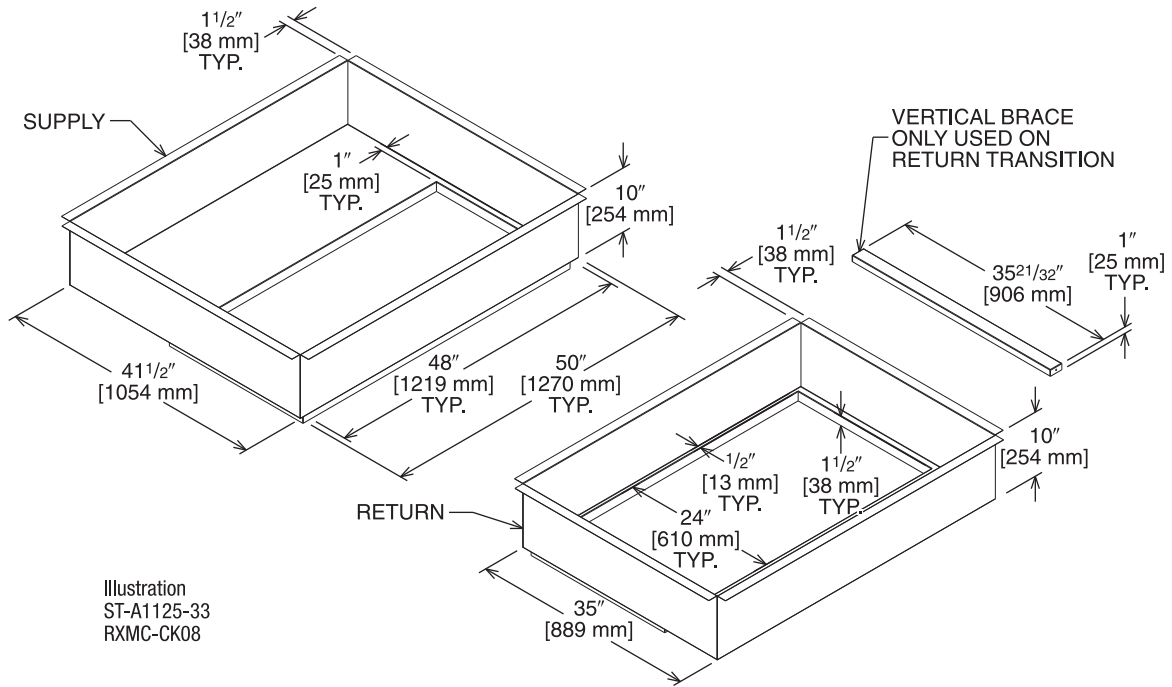

Illustration
ST-A1125-24

DOWNFLOW TRANSITION DRAWINGS

RXMC-CK08 (20 Ton) [70.3 kW]

- Used with RXRN-AD86 Concentric Diffusers



RXMC-CL09 (25 Ton) [87.9 kW]

- Used with RXRN-AD88 Concentric Diffusers

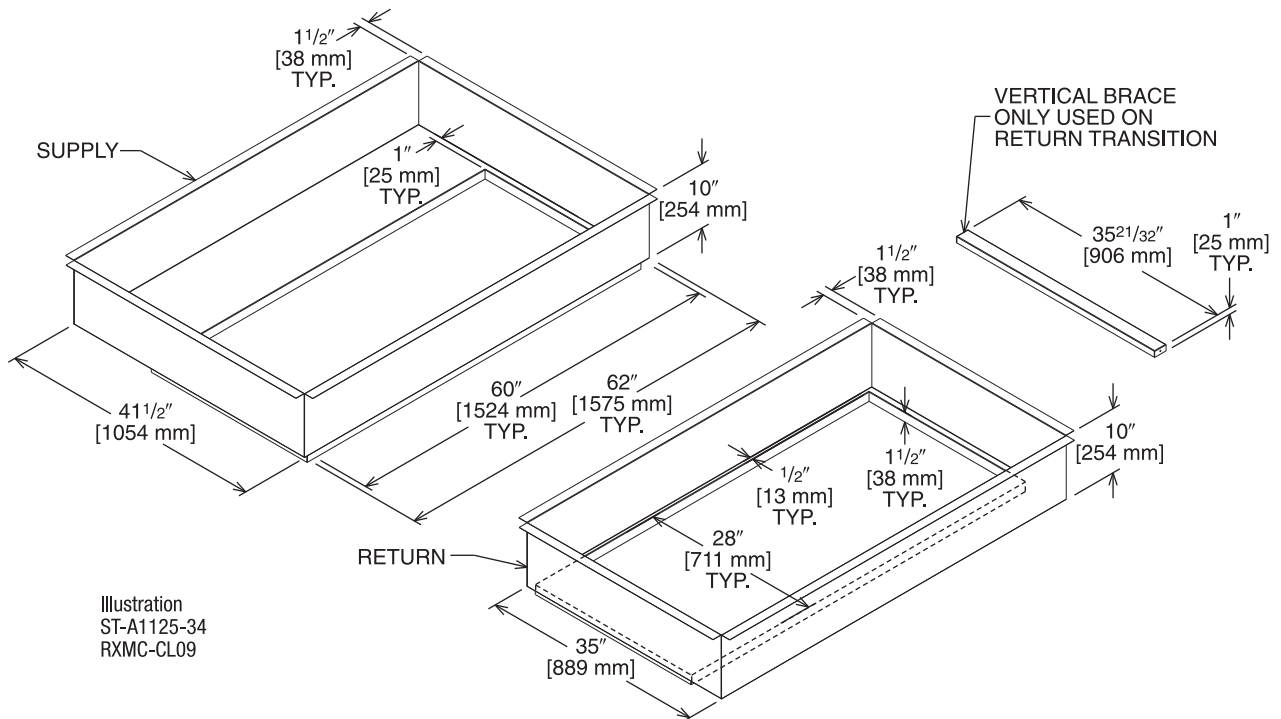

[] Designates Metric Conversions

CONCENTRIC DIFFUSER RXRN-AD88 SERIES

- All aluminum diffuser with aluminum return air eggcrate.
- Built-in anti-sweat gasket.
- Molded fiberglass supports.
- Built-in hanging supports.
- Diffuser box constructed of sheetmetal insulated with 1" [25.4 mm] 1.5 lbs. [.7 kg] duct liner.
- Double deflection diffuser with the blades secured by spring steel.

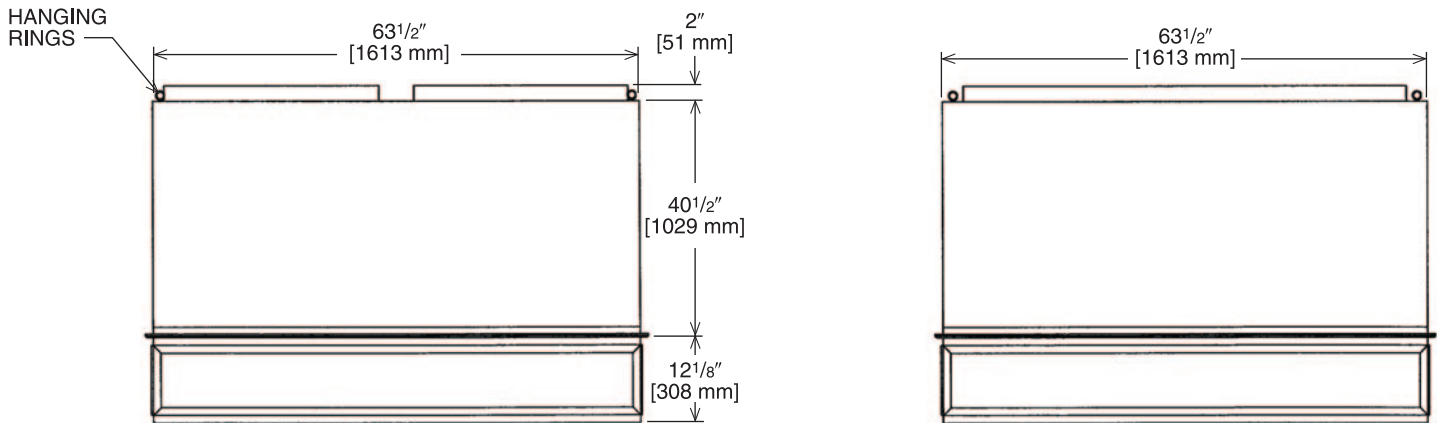
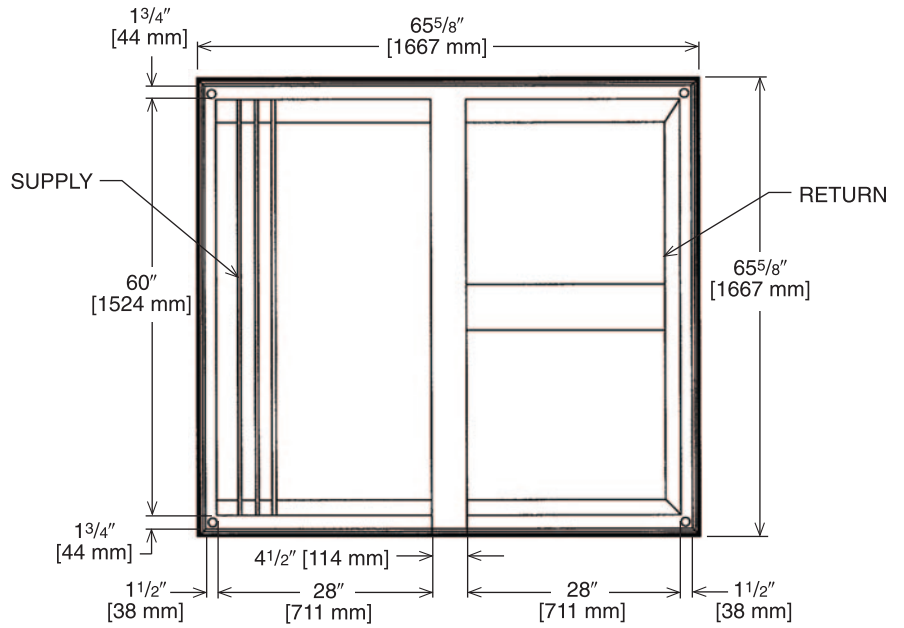

CONCENTRIC DIFFUSER SPECIFICATIONS

PART NUMBER	CFM [L/s]	STATIC PRESSURE	THROW FEET	NECK VELOCITY	JET VELOCITY
RXRN-AD88	10000 [4719]	0.51	46-54	907	907
	10500 [4955]	0.58	50-58	953	953
	11000 [5191]	0.65	53-61	998	998
	11500 [5427]	0.73	55-64	1043	1043
	12000 [5663]	0.82	58-67	1089	1089
	12500 [5898]	0.91	61-71	1134	1134
	13000 [6134]	1.00	64-74	1179	1179

[] Designates Metric Conversions

Guide Specifications RGEH

You may copy this document directly into your building specification. This specification is written to comply with the 2004 version of the "master format" as published by the Construction Specification Institute. www.csinet.org.

GAS HEAT PACKAGED ROOFTOP

HVAC Guide Specifications

Size Range: 30 Nominal Tons

<u>Section</u>	<u>Description</u>
----------------	--------------------

23 06 80	Schedules for Decentralized HVAC Equipment
-----------------	---

23 06 80.13	Decentralized Unitary HVAC Equipment Schedule
-------------	---

23 06 80.13.A.	Rooftop unit schedule
----------------	-----------------------

1. Schedule is per the project specification requirements.

23 07 16	HVAC Equipment Insulation
-----------------	----------------------------------

23 07 16.13	Decentralized, Rooftop Units:
-------------	-------------------------------

1. Interior cabinet surfaces shall be insulated with a minimum 3/4-in. thick, minimum 1-1/2 lb density, flexible fiberglass insulation bonded with a phenolic binder, with aluminum foil facing on the air side.
2. Insulation and adhesive shall meet NFPA 90A requirements for flame spread and smoke generation.

23 09 13	Instrumentation and Control Devices for HVAC
-----------------	---

23 09 13.23	Sensors and Transmitters
-------------	--------------------------

23 09 13.23.A.	Thermostats
----------------	-------------

1. Unit controlled by return air or optional duct/space sensor.
2. Building Management System is recommended.

23 09 23	Direct-digital Control system for HVAC
-----------------	---

23 09 23.13	Decentralized, Rooftop Units:
-------------	-------------------------------

23 09 23.13.A.	RTU-C controller
----------------	------------------

1. Shall be ASHRAE 62-2001 compliant.
2. Shall accept 18-32VAC input power.
3. Shall have an operating temperature range from -40°F (-40°C) to 158°F (70°C), 10% - 95% RH (non-condensing).
4. Controller shall accept the following inputs: space temperature, setpoint adjustment, outdoor air temperature, indoor air quality, outdoor air enthalpy, fire shutdown, return air enthalpy, fan status, remote time clock/door switch.
5. Shall accept a CO₂ sensor in the conditioned space, and be Demand Control Ventilation (DCV) ready.
6. Shall provide the following outputs: Economizer, fan, cooling stage 1, cooling stage 2, cooling stage 3, cooling stage 4, cooling stage 5, heat stage 1, heat stage 2 exhaust/ occupied.
7. Unit shall provide surge protection for the controller through a circuit breaker.
8. Shall have a field installed communication card allowing the unit to be Internet capable, and communicate at a Baud rate of 19.2K or faster.
9. Shall have an LED display independently showing the status of activity on the communication bus, and processor operation.
10. Shall have a field installed BACnet® plug-in communication card which includes an EIA-485 protocol communication port.
11. Software upgrades will be accomplished by local download. Software upgrades through chip replacements are not allowed.
12. Shall be shock resistant in all planes to 5G peak, 11ms during operation, and 100G peak, 11ms during storage.
13. Shall be vibration resistant in all planes to 1.5G @ 20-300 Hz.
14. Shall support a bus length of 4000 ft. max, 60 devices per 1000 ft. section, and 1 RS-485 repeater per 1000 ft. sections.

23 09 23.13.B.	Open protocol, direct digital controller:
----------------	---

1. Shall be ASHRAE 62-2001 compliant.
2. Shall accept 18-30VAC, 50-60Hz, and consume 15VA or less power.
3. Shall have an operating temperature range from -40°F (-40°C) to 130°F (54°C), 10%-90% RH (non-condensing).
4. Shall have a field installed BACnet® plug-in communication card which includes an EIA-485 protocol communication port.
5. The BACnet® plug in communication card shall include built-in protocol for BACNET (MS/TP and PTP modes)
6. Shall allow access of up to 62 network variables (SNVT). Shall be compatible with all open controllers
7. Baud rate Controller shall be selectable through the EIA-485 protocol communication port.
8. Shall have an LED display independently showing the status of serial communication, running, errors, power, all digital outputs, and all analog inputs.
9. Shall accept the following inputs: space temperature, setpoint adjustment, outdoor air temperature, indoor air quality, outdoor air enthalpy, compressor lock-out, fire shutdown, enthalpy switch, and fan status/filter status/ humidity/ remote occupancy.
11. Shall provide the following outputs: economizer, fan, cooling stage 1, cooling stage 2, cooling stage 3, cooling stage 4, cooling stage 5, heat stage 1, heat stage/ exhaust.
12. Software upgrades will be accomplished by either local or remote download. No software upgrades through chip replacements are allowed.

23 09 33 Electric and Electronic Control System for HVAC

23 09 33.13 Decentralized, Rooftop Units:

23 09 33.13.A. General:

1. Shall be complete with self-contained low-voltage control circuit protected by a resettable circuit breaker on the 24-v transformer side. Transformer shall have 100VA capabilities.
2. Shall utilize color-coded wiring.
3. The heat exchanger shall be controlled by an integrated furnace controller (IFC) microprocessor. See heat exchanger section of this specification.
4. Shall include a central control terminal board to conveniently and safely provide connection points for vital control functions such as: smoke detectors, phase monitor, economizer, thermostat, DDC control options, loss of charge, freeze sensor, high pressure switches.
5. Standard DDC ClearControl.
6. Standard Variable Air Volume controls.
7. Unit shall include a minimum of one 10-pin screw terminal connection board for connection of control wiring.

23 09 33.23.B. Safeties:

1. Compressor over-temperature, over current.
2. Loss of charge switch.
 - a. Units with 2 compressors shall have different colored wires for the circuit 1 and circuit 2 low and high pressure switches.
 - b. Loss of charge switch shall use different color wire than the high pressure switch. The purpose is to assist the installer and service technician to correctly wire and/or troubleshoot the rooftop unit.
 - c. Loss of charge switch shall have a different sized connector than the high pressure switch. They shall physically prevent the cross-wiring of the safety switches between the high and low pressure side of the system.
3. High-pressure switch.
 - a. Units with 2 compressors shall have different colored wires for the circuit 1 and circuit 2 low and high pressure switches.
 - b. High pressure switch shall use a different color wire than the low pressure switch. The purpose is to assist the installer and service person to correctly wire and or troubleshoot the rooftop unit.
 - c. High pressure switch shall have a different sized connector than the loss of charge switch. They shall physically prevent the cross-wiring of the safety switches between the high and low pressure side of the system.
4. Freeze protection sensor, evaporator coil.
5. Automatic reset, motor thermal overload protector.
6. Heating section shall be provided with the following minimum protections.
 - a. High-temperature limit switches.
 - b. Induced draft motor pressure switch.
 - c. Flame rollout switch.
 - d. Flame proving controls.

23 09 93 Sequence of Operations for HVAC Controls

23 09 93.13 Decentralized, Rooftop Units:

23 40 13 Panel Air Filters

23 40 13.13 Decentralized, Rooftop Units:

23 40 13.13.A. Standard filter section shall

1. Shall consist of factory-installed, low velocity, throwaway 2-in. thick fiberglass filters of commercially available sizes.
2. Unit shall use only one filter size. Multiple sizes are not acceptable.
3. Filter face velocity shall not exceed 365 fpm at nominal airflows.
4. Filters shall be accessible through an access panel as described in the unit cabinet section of the specification (23 81 19.13.H).

23 81 19 Self-Contained Air Conditioners

23 81 19.13 Small-Capacity Self-Contained Air Conditioners

23 81 19.13.A. General

1. Outdoor, rooftop mounted, electrically controlled, heating and cooling unit utilizing a(n) hermetic scroll compressor(s) for cooling duty and gas combustion for heating duty.
2. Factory assembled, single-piece heating and cooling rooftop unit. Contained within the unit enclosure shall be all factory wiring, piping, controls, and special features required prior to field start-up.
3. Unit shall use environmentally safe, R-410A refrigerant.
4. Unit shall be installed in accordance with the manufacturer's instructions.
5. Unit must be selected and installed in compliance with local, state, and federal codes.

23 81 19.13.B. Quality Assurance

1. Unit meets ASHRAE 90.1-2019 minimum efficiency requirements.
2. Unit shall be rated in accordance with AHRI Standard 340/360.
3. Unit shall be designed to conform to ASHRAE 15, 2001.
4. Unit shall be UL-tested and certified in accordance with ANSI Z21.47 Standards and UL-listed and certified under Canadian standards as a total package for safety requirements.
5. Insulation and adhesive shall meet NFPA 90A requirements for flame spread and smoke generation.
6. Unit casing shall be capable of withstanding 500-hour salt spray exposure per ASTM B117 (scribed specimen).
7. Unit casing shall be capable of withstanding Federal Test Method Standard No. 141 (Method 6061) 5000-hour salt spray.
8. Unit shall be designed in accordance with ISO 9001:2015 and shall be manufactured in a facility registered by ISO 9001:2015.
9. Roof curb shall be designed to conform to NRCA Standards.
10. Unit shall be subjected to a completely automated run test on the assembly line. The data for each unit will be stored at the factory and must be available upon request.
11. Unit shall be designed in accordance with UL Standard 1995, including tested to withstand rain.
12. Unit shall be constructed to prevent intrusion of snow and tested to prevent snow intrusion into the control box up to 40 mph.

23 81 19.13.C. Delivery, Storage, and Handling

1. Unit shall be stored and handled per manufacturer's recommendations.
2. Lifted by crane requires either shipping top panel or spreader bars.
3. Unit shall only be stored or positioned in the upright position.

23 81 19.13.E. Project Conditions

1. As specified in the contract.

23 81 19.13.F. Operating Characteristics

1. Unit shall be capable of starting and running at 115°F (46°C) ambient outdoor temperature, meeting maximum load criteria of AHRI Standard 340/360 at ± 10% voltage.
2. Compressor with standard controls shall be capable of operation down to 40°F (4°C), ambient outdoor temperatures. Accessory low ambient kit is necessary if mechanically cooling at ambient temperatures below 40°F (4°C).
3. Unit shall discharge supply air vertically or horizontally as shown on contract drawings.
4. Unit shall be factory configured for vertical supply & return configurations.
5. Unit shall be field convertible from vertical to horizontal configuration.

23 81 19.13.G. Electrical Requirements

1. Main power supply voltage, phase, and frequency must match those required by the manufacturer.

23 81 19.13.H. Unit Cabinet

1. Unit cabinet shall be constructed of galvanized steel, and shall be bonderized and coated with a baked enamel finish on all externally exposed surfaces.
2. Unit cabinet exterior paint shall be: film thickness, (dry) 0.003 inches minimum, gloss (per ASTM D523, 60°F / 16°C): 60, Hardness: H-2H Pencil hardness.
3. Evaporator fan compartment interior cabinet insulation shall conform to AHRI Standards 210 or 360 minimum exterior sweat criteria. Interior surfaces shall be insulated with a minimum 3/4-in. thick, 1 lb. density, flexible fiberglass insulation, aluminum foil-face coated on the air side.
4. Base of unit shall have locations for thru-the-base gas and electrical connections (factory installed or field installed), standard.
5. Base Rail
 - a. Unit shall have base rails on all sides.
 - b. Holes shall be provided in the base rails for rigging shackles to facilitate maneuvering and overhead rigging.
 - c. Holes shall be provided in the base rail for moving the rooftop by fork truck.
 - d. Base rail shall be a minimum of 14 gauge thickness.
6. Condensate pan and connections:
 - a. Shall be a sloped condensate drain pan made of a non-corrosive material.
 - b. Shall comply with ASHRAE Standard 62.
 - c. Shall use a 1" x 11-1/2 NPT drain connection through the side of the drain pan. Connection shall be made per manufacturer's recommendations.

7. Gas Connections:

- a. All gas piping connecting to unit gas valve shall enter the unit cabinet at a single location on side of unit (horizontal plane).
- b. Thru-the-base capability
 - i. Standard unit shall have a thru-the-base gas-line location using a raised, embossed portion of the unit basepan.
 - ii. No basepan penetration, other than those authorized by the manufacturer, is permitted.

8. Electrical Connections

- a. All unit power wiring shall enter unit cabinet at a single, factory-prepared, knockout location.
- b. Thru-the-base capability
 - i. Standard unit shall have a thru-the-base electrical location(s) using a raised, embossed portion of the unit basepan.
 - ii. No basepan penetration, other than those authorized by the manufacturer, is permitted.

9. Component hinged access panels (standard)

- a. Cabinet panels shall be hinged for servicing.
- b. Stainless steel metal hinges are standard on all doors.
- c. Panels covering control box, indoor fan, indoor fan motor and gas components (where applicable), shall have 1/4 turn latches.

23 81 19.13.I. Gas Heat

1. General

- a. Heat exchanger shall be an induced draft design. Positive pressure heat exchanger designs shall not be allowed.
- b. Shall incorporate a direct-spark ignition system and redundant main gas valve.
- c. Heat exchanger design shall allow combustion process condensate to gravity drain; maintenance to drain the gas heat exchanger shall not be required.
- d. Gas supply pressure at the inlet to the rooftop unit gas valve must match that required by the manufacturer.

2. The heat exchanger shall be controlled by an integrated furnace controller (IFC) microprocessor.

- a. IFC board shall notify users of fault using an LED (light-emitting diode).

3. Standard Heat Exchanger construction

- a. Heat exchanger shall be of the tubular-section type constructed of a minimum of 20-gauge aluminum coated steel for corrosion resistance.
- b. Burners shall be of the in-shot type constructed of aluminum-coated steel.
- c. Burners shall incorporate orifices for rated heat output up to 2000 ft. (610m) elevation. Additional accessory kits may be required for applications above 2000 ft. (610m) elevation, depending on local gas supply conditions.

4. Optional Stainless Steel Heat Exchanger construction

- a. Use energy saving, direct-spark ignition system.
- b. Use a redundant main gas valve.
- c. Burners shall be of the in-shot type constructed of aluminum-coated steel.
- d. All gas piping shall enter the unit cabinet at a single location on side of unit (horizontal plane).
- e. The optional stainless steel heat exchanger shall be of the tubular-section type, constructed of a minimum of 20-gauge type 409 stainless steel.
- f. Type 409 stainless steel shall be used in heat exchanger tubes and vestibule plate.
- g. Complete stainless steel heat exchanger allows for greater application flexibility.

5. Induced draft combustion motors and blowers

- a. Shall be a direct-drive, single inlet, forward-curved centrifugal type.
- b. Shall be made from steel with a corrosion-resistant finish.
- c. Shall have permanently lubricated sealed bearings.
- d. Shall have inherent thermal overload protection.
- e. Shall have an automatic reset feature.

23 81 19.13.J. Coils

1. Standard Aluminum/Copper Coils:

- a. Standard evaporator and condenser coils shall have aluminum lanced plate fins mechanically bonded to seamless internally grooved copper tubes with all joints brazed.
- b. Evaporator and condenser coils shall be leak tested to 150 psig, pressure tested to 550 psig, and qualified to UL 1995 burst test at 2,200 psi.

23 81 19.13.K. Refrigerant Components

1. Refrigerant circuit shall include the following control, safety, and maintenance features:
 - a. Thermal Expansion Valves (TXV) with orifice type distributor.
 - b. Refrigerant filter drier.
 - c. Service gauge connections on suction and discharge lines.
 - d. Pressure gauge access through an access port in the front and rear panel of the unit.
2. Compressors
 - a. Unit shall use one fully hermetic, scroll compressor for each independent refrigeration circuit.
 - b. Compressor motors shall be cooled by refrigerant gas passing through motor windings.
 - c. Compressors shall be internally protected from high discharge temperature conditions. Advanced Scroll Temperature Protection on 240-300 sizes.
 - d. Compressors shall be protected from an over-temperature and over-amperage conditions by an internal, motor overload device.
 - e. Compressor shall be factory mounted on rubber grommets.
 - f. Compressor motors shall have internal line break thermal and current overload protection.
 - g. Crankcase heaters shall not be required for normal operating range.

23 81 19.13.L. Filter Section

1. Filters access is specified in the unit cabinet section of this specification.
2. Filters shall be held in place by filter tray, facilitating easy removal and installation.
3. Shall consist of factory-installed, low velocity, throw-away 2-in. thick fiberglass filters.
4. Filter face velocity shall not exceed 365 fpm at nominal airflows.
5. Filters shall be standard, commercially available sizes.
6. Only one size filter per unit is allowed.
7. Optional MERV 8 and MERV 13 filters.

23 81 19.13.M. Evaporator Fan and Motor

1. Evaporator fan motor:
 - a. Shall have permanently lubricated bearings.
 - b. Shall have inherent automatic-reset thermal overload protection.
 - c. Shall have a maximum continuous bhp rating for continuous duty operation; no safety factors above that rating shall be required.
2. Belt-driven Evaporator Fan:
 - a. Belt drive shall include an adjustable-pitch motor pulley.
 - b. Shall use sealed, permanently lubricated ball-bearing type.
 - c. Blower fan shall be double-inlet type with forward-curved blades.
 - d. Shall be constructed from steel with a corrosion resistant finish and dynamically balanced.

23 81 19.13.N. Condenser Fans and Motors

1. Condenser fan motors:
 - a. Shall be a totally enclosed motor.
 - b. Shall use permanently lubricated bearings.
 - c. Shall have inherent thermal overload protection with an automatic reset feature.
 - d. Shall use a shaft-down design. Shaft-up designs including those with "rain-slinger devices" shall not be allowed.
2. Condenser Fans shall:
 - a. Shall be a direct-driven propeller type fan.
 - b. Shall have aluminum blades riveted to corrosion-resistant steel spiders and shall be dynamically balanced.

23 81 19.13.O. Special Features

1. Integrated Economizers:
 - a. Integrated, gear-driven parallel modulating blade design type capable of simultaneous economizer and compressor operation.
 - b. Independent modules for vertical or horizontal return configurations shall be available. Only Vertical return modules shall be available as a factory installed option.
 - c. Damper blades shall be galvanized steel with metal gears. Plastic or composite blades on intake or return shall not be acceptable.

- d. Shall include all hardware and controls to provide free cooling with outdoor air when temperature and/or humidity are below setpoints.
 - e. Shall be equipped with gear driven dampers for both the outdoor ventilation air and the return air for positive air stream control.
 - f. Shall be capable of introducing up to 100% outdoor air.
 - g. Shall be equipped with a barometric relief damper capable of relieving up to 100% return air. The barometric relief damper shall include seals, hardware and hoods to relieve building pressure. Damper shall gravity close upon unit shut down.
 - h. Shall be designed to close damper(s) during loss-of-power situations with spring return built into motor.
 - i. An outdoor single-enthalpy sensor shall be provided as standard. Outdoor air enthalpy set point shall be adjustable and shall range from the enthalpy equivalent of 63°F @ 50% rh to 73°F @ 50% rh. Additional sensor options shall be available as accessories.
 - j. The economizer controller shall also provide control of an accessory power exhaust unit function. Factory set at 70%, with a range of 0% to 100%.
 - k. The economizer shall maintain minimum airflow into the building during occupied period and provide design ventilation rate for full occupancy. A remote potentiometer may be used to override the damper set point.
 - l. Economizer controller shall accept a 2-10Vdc CO2 sensor input for IAQ/DCV control. In this mode, dampers shall modulate the outdoor-air damper to provide ventilation based on the sensor input.
 - m. Actuator shall be direct coupled to economizer gear. No linkage arms or control rods shall be acceptable.
 - n. Economizer controller shall provide indications when in free cooling mode, in the DCV mode, or the exhaust fan contact is closed.
2. Two-Position Damper
- a. Damper shall be a Two-Position Damper. Damper travel shall be from the full closed position to the field adjustable % open setpoint.
 - b. Damper shall include adjustable damper travel from 25% to 100% (full open).
 - c. Damper shall include single or dual blade, gear driven damper and actuator motor.
 - d. Actuator shall be direct coupled to economizer gear. No linkage arms or control rods shall be acceptable.
 - e. Damper will admit up to 100% outdoor air for applicable rooftop units.
 - f. Damper shall close upon indoor (evaporator) fan shutoff and/or loss of power.
 - g. The damper actuator shall plug into the rooftop unit's wiring harness plug. No hard wiring shall be required.
 - h. Outside air hood shall include aluminum water entrainment filter.
3. Manual damper
- a. Manual damper package shall consist of damper, air inlet screen, and rain hood which can be preset to admit up to 50% outdoor air for year-round ventilation.
4. Head Pressure Control Package
- a. Controller shall control coil head pressure by condenser-fan cycling.
5. Liquid Propane (LP) Conversion Kit
- a. Package shall contain all the necessary hardware and instructions to convert a standard natural gas unit for use with liquefied propane, up to 2000 ft. (610m) elevation.
6. Unit-Mounted, Non-Fused Disconnect Switch:
- a. Switch shall be factory-installed, internally mounted.
 - b. National Electric Code (NEC) and UL approved non-fused switch shall provide unit power shutoff.
 - c. Shall be accessible from outside the unit.
 - d. Shall provide local shutdown and lockout capability.
7. Non-Powered convenience outlet.
- a. Outlet shall be powered from a separate 115-120v power source.
 - b. A transformer shall not be included.
 - c. Outlet shall be field-installed and internally mounted with easily accessible 115-v female receptacle.
 - d. Outlet shall include 15 amp GFI receptacle.
 - e. Outlet shall be accessible from outside the unit.
8. Flue Discharge Deflector:
- a. Flue discharge deflector shall direct unit exhaust vertically instead of horizontally.
 - b. Deflector shall be defined as a "natural draft" device by the National Fuel and Gas (NFG) code.

9. Thru-the-Base Connectors:
 - a. Kits shall provide connectors to permit gas and electrical connections to be brought to the unit through the unit basepan.
10. Propeller Power Exhaust:
 - a. Power exhaust shall be used in conjunction with an integrated economizer.
 - b. Independent modules for vertical or horizontal return configurations shall be available.
 - c. Horizontal power exhaust shall be mounted in return ductwork.
 - d. Power exhaust shall be controlled by economizer controller operation. Exhaust fans shall be energized when dampers open past the 0-100% adjustable setpoint on the economizer control.
11. Roof Curbs (Vertical):
 - a. Full perimeter roof curb with exhaust capability providing separate airstreams for energy recovery from the exhaust air without supply air contamination.
 - b. Formed galvanized steel with wood nailer strip and shall be capable of supporting entire unit weight.
 - c. Permits installation and securing of ductwork to curb prior to mounting unit on the curb.
12. Universal Gas Conversion Kit:
 - a. Package shall contain all the necessary hardware and instructions to convert a standard natural gas unit to operate from 2000-7000 ft. (610 to 2134m) elevation with natural gas or from 0-7000 ft. (90-2134m) elevation with liquified propane.
13. Outdoor Air Enthalpy Sensor:
 - a. The outdoor air enthalpy sensor shall be used to provide single enthalpy control. When used in conjunction with a return air enthalpy sensor, the unit will provide differential enthalpy control. The sensor allows the unit to determine if outside air is suitable for free cooling.
14. Return Air Enthalpy Sensor:
 - a. The return air enthalpy sensor shall be used in conjunction with an outdoor air enthalpy sensor to provide differential enthalpy control.
15. Indoor Air Quality (CO₂) Sensor:
 - a. Shall be able to provide demand ventilation indoor air quality (IAQ) control.
 - b. The IAQ sensor shall be available in wall mount with LED display. The set point shall have adjustment capability.
16. Smoke detectors:
 - a. Shall be a Four-Wire Controller and Detector.
 - b. Shall be environmental compensated with differential sensing for reliable, stable, and drift-free sensitivity.
 - c. Shall use magnet-activated test/reset sensor switches.
 - d. Shall have tool-less connection terminal access.
 - e. Shall have a recessed momentary switch for testing and resetting the detector.
 - f. Controller shall include:
 - i. One set of normally open alarm initiation contacts for connection to an initiating device circuit on a fire alarm control panel
 - ii. Two Form-C auxiliary alarm relays for interface with rooftop unit or other equipment.
 - iii. One Form-C supervision (trouble) relay to control the operation of the Trouble LED on a remote test/reset station.
 - iv. Capable of direct connection to two individual detector modules.
 - v. Can be wired to up to 14 other duct smoke detectors for multiple fan shutdown applications.
17. Blower:
 - a. Blower shall be removable without removing the roof of the unit or the condenser fan motors. Blower shall be able to slide out from the blower compartment of the unit.
18. Hinged Panels:
 - a. All hinged panels are standard.

26 29 23.12.Adjustable Frequency Drive

1. Unit shall be supplied with an electronic variable frequency drive for the supply air fan.
2. Drive shall be factory installed in an enclosed cabinet.
3. Drive shall meet UL Standard 95-5V.
4. The completed unit assembly shall be UL listed.
5. Drives are to be accessible through a tooled access hinged door assembly.
6. The unit manufacturer shall install all power and control wiring.
7. The supply air fan drive output shall be controlled by the factory installed main unit control system and drive status and operating speed shall be monitored and displayed at the main unit control panel.
8. Drive shall be programmed and factory run tested in the unit.

BEFORE PURCHASING THIS APPLIANCE, READ IMPORTANT ENERGY COST AND EFFICIENCY INFORMATION AVAILABLE FROM YOUR RETAILER.

GENERAL TERMS OF LIMITED WARRANTY*

Friedrich® will furnish a replacement for any part of this product which fails in normal use and service within the applicable periods stated, in accordance with the terms of the limited warranty.

Compressor

3 Phase, Commercial Applications.....Five (5) Years

Parts

3 Phase, Commercial ApplicationsOne (1) Year

Factory Standard Heat Exchanger

3 Phase, Commercial ApplicationsTen (10) Years

Stainless Steel Heat Exchanger

3 Phase, Commercial ApplicationsTwenty (20) Years

***For complete details of the Limited and Conditional Warranties, including applicable terms and conditions, contact your local contractor or the Manufacturer for a copy of the product warranty certificate.**



FRIEDRICH

1 8 8 3

Before proceeding with installation, refer to installation instructions packaged with each model, as well as complying with all Federal, State, Provincial, and Local codes, regulations, and practices.

© 2023 Rheem Manufacturing Company. Friedrich trademarks owned by Rheem Manufacturing Company.

In keeping with its policy of continuous progress and product improvement, Friedrich reserves the right to make changes without notice.

Friedrich • 5600 Old Greenwood Road
Fort Smith, Arkansas 72908 • www.friedrich.com

Friedrich • 125 Edgeware Road, Unit 1
Brampton, Ontario • L6Y 0P5