



FRIEDRICH

1 8 8 3

Commercial Renaissance® Line F-Series Plus™ Packaged Heat Pumps



RHPDYC Series

Efficiencies up to: 12.0 EER, 17.6 IEER & 3.6 COP

Nominal Sizes: 6.5, 7.5, 8.5 & 10 Tons [22.9, 26.4, 29.9 & 35.2 kW]

Cooling Capacities: 74k Btu/h to 114k Btu/h

Refrigerant Type: R-454B

ASHRAE 90.1 2022 Compliant Models



9001:2015



LISTED



TABLE OF CONTENTS

Unit Features & Benefits.....	3-9
Model Number Identification	10
Options	11
Selection Procedure	12
General Data	13-14
General Data Notes	15
Gross Systems Performance Data.....	16-21
Airflow Performance Data	22-43
Electrical Data	44
Electric Heater Kits.....	45-46
Safety Data	47
Dimensional Data	48-51
Field-Installed Accessories	52-70
Guide Specifications	71-76
Limited Warranty	77



RHPDYC STANDARD FEATURES INCLUDE:

Manufacturing & Quality Features

- Factory charged with R-454B refrigerant
- Wired and run tested at the factory
- Powder Paint Finish meets ASTM® B117 test requirements. G90 galvanized steel coated on each side
- Foil faced insulation encapsulated throughout entire unit minimizes airborne fibers in the air stream

Performance Features

- Advanced unitary controller for easier integration and setup with easy to read and use 3" LCD screen
- Standard compatibility with Universal 24V control as well as BACnet® MS/TP- and BACnet IP-ready
- Backward-curve direct-drive indoor blower
- Cooling operation up to 125°F ambient
- Scroll compressors with internal line break overload and high-pressure protection
- Three stages of cooling and two stages of heat pump heating operation
- Full MicroChannel coils with patented defrost design
- High pressure and low pressure/loss of charge protection

Convenience & Serviceability Features

- Forkable base rails for easy handling and lifting
- Color-coded and labeled wiring
- Laser-etched panel doors to identify each compartment from the exterior
- External, lockable gauge ports
- Field convertible airflow—vertical downflow or horizontal sideflow
- Solid-core liquid line filter drier
- Filter access features hinged access with heavy-duty gasketing and 1/4 turn latches
- Slide-out indoor fan assembly for added service convenience
- Slide-out, internally sloped condensate drain pan with overflow switch, conforms to ASHRAE 62 standards
- Qwik-change flex-fit filter rack for easy filter size changes
- Factory-installed refrigerant leak detection system

FACTORY-INSTALLED OPTIONS:

- Louvered panels
- Hinged access doors
- Low ambient/freeze stat
- Non-powered convenience outlet
- Vertical Economizer (Title 24 and ASHRAE 90.1 2022 compliant)
- Supply and return smoke detector
- ElectroFin® E-Coat for MicroChannel Condenser Coil

FIELD-INSTALLED ACCESSORY EQUIPMENT:

Accessory	Model Number	Factory Installation Available?
Non-DDC Economizer with Single Enthalpy (Downflow) <i>MicroMetl Economizer with Siemens® Controls</i>	RXRD-11MDDAM3	Yes
Non-DDC Economizer with Single Enthalpy (Downflow) <i>RRS Economizer with Siemens Controller</i>	RXRD-51MDDAM3	No
Non-DDC Economizer with Single Enthalpy (Horizontal) <i>MicroMetl Economizer with Siemens Controls</i>	RXRD-11MDHAM3	No
Non-DDC Economizer with Single Enthalpy (Horizontal) <i>RRS Economizer with Siemens Controller</i>	RXRD-51MDHAM3	No
Power Exhaust (230V) Kit for Downflow Economizer <i>RRS</i>	RXRX-RDF01C	No
Power Exhaust (230V) Kit for Horizontal Economizer <i>RRS</i>	RXRX-RDF03C	No
Power Exhaust (230V) Kit, Convertible <i>MicroMetl</i>	RXRX-CDF01C	No
Power Exhaust (460V) Kit for Downflow Economizer <i>RRS</i>	RXRX-RDF01D	No
Power Exhaust (460V) Kit for Horizontal Economizer <i>RRS</i>	RXRX-RDF03D	No
Power Exhaust (460V) Kit, Convertible <i>MicroMetl</i>	RXRX-CDF01D	No
Convenience Outlet, Non-Powered	RXRX-BN01	Yes
Electric Heater Kit 208/230V, 3ph, 10kW	RXJJ-ED10CP	Yes
Electric Heater Kit 208/230V, 3ph, 15kW	RXJJ-ED15CP	Yes
Electric Heater Kit 208/230V, 3ph, 20kW	RXJJ-ED20CP	Yes
Electric Heater Kit 208/230V, 3ph, 30kW	RXJJ-ED30CP	Yes
Electric Heater Kit 208/230V, 3ph, 40kW	RXJJ-ED40CP	Yes
Electric Heater Kit 460V, 3ph, 10kW	RXJJ-ED10DNV	Yes
Electric Heater Kit 460V, 3ph, 15kW	RXJJ-ED15DNV	Yes
Electric Heater Kit 460V, 3ph, 20kW	RXJJ-ED20DNV	Yes
Electric Heater Kit 460V, 3ph, 30kW	RXJJ-ED30DNV	Yes
Electric Heater Kit 460V, 3ph, 40kW	RXJJ-ED40DNV	Yes
Fresh Air Damper, Manual	RXRF-ADA1	No
Fresh Air Damper, Motorized	RXRF-ADB1	No
Roofcurb Adapter	RXRX-DDCAE	No
Roofcurb, 14"	RXKG-DDD14	No
Roofcurb, 24"	RXKG-DDD24	No

Accessory	Model Number	Factory Installation Available?
Unfused Service Disconnect	RXRX-BP01	Yes
UV-C Light Kit 208/230V	RXRX-UVC34D	No
UV-C Light Kit Transformer 460V/575V	RXRX-UVCTD	No
Concentric Adapter 6.5, 7.5, 8.5 Ton Drop	RXMC-DD01	No
Concentric Adapter 10 Ton Drop	RXMC-DD02	No
Concentric Diffuser 6.5, 7.5, 8.5 Ton Drop	RXRN-AED2000	No
Concentric Diffuser 10 Ton Drop	RXRN-AED3415	No
Concentric Diffuser 6.5, 7.5, 8.5 Ton Flush	RXRN-AEF2000	No
Concentric Diffuser 10 Ton Flush	RXRN-AEF3415	No
MERV 8 Filter 6.5 Ton	RXMF-M08A22020	No
MERV 8 Filter 7.5, 8.5 & 10 Ton	RXMF-M08A22520	No
MERV 13 Filter 6.5 Ton	RXMF-M13A22020	No
MERV 13 Filter 7.5, 8.5 & 10 Ton	RXMF-M13A22520	No
Outdoor Coil Louver Kit - 6.5 Ton	RXRX-ADD04A	Yes
Outdoor Coil Louver Kit - 7.5, 8.5 & 10 Ton	RXRX-ADD04B	Yes
Single Point Wiring Kit 208/230V, 60A, 6.5 Ton	RXJX-AC0605	No
Single Point Wiring Kit 208/230V, 80A, 6.5 Ton	RXJX-AC0805	No
Single Point Wiring Kit 460V, 30A, 6.5 Ton	RXJX-AD0305	No
Single Point Wiring Kit 460V, 60A, 6.5 Ton	RXJX-AD0605	No
Single Point Wiring Kit 208/230V, 70A, 10 Ton	RXJX-AC0709	No
Single Point Wiring Kit 208/230V, 90A, 7.5, 8.5 & 10 Ton	RXJX-AC0909	No
Single Point Wiring Kit 460V, 40A, 7.5, 8.5 & 10 Ton	RXJX-AD0409	No
Single Point Wiring Kit 460V, 60A, 7.5, 8.5 & 10 Ton	RXJX-AD0609	No
Dual Enthalpy, Temperature and Humidity Sensor (for Siemens)	PD555460	No
Low-Ambient Control Kit	RXRZ-A07	Yes
Sensor, Carbon Dioxide (Wall Mount)	RXRX-AR02	No
Smoke Detector Kit, Return	RXRX-BS03	No
Smoke Detector Kit, Return/Supply	RXRX-BS04	No

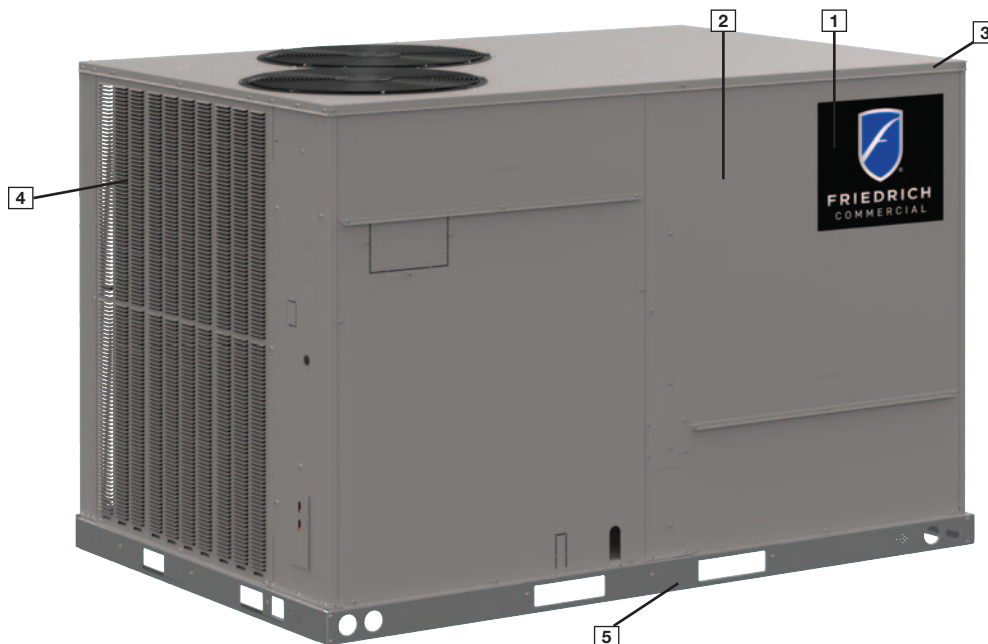

Cabinet and Foundation

Outwardly, the large Friedrich® Renaissance label (1) identifies the brand to the customer. The sheet-metal cabinet (2) uses 18-gauge material for structural components with an underlying coat of G90. To ensure the leak-proof integrity of these units, the design utilizes a one-piece top with a 1/8" drip lip (3) as well as gasket-protected panels and screws. The Friedrich hail guard (optional) (4) sets the standard for coil protection in the industry. Electro deposition, baked-on enamel that is tested to withstand a rigorous 1000-hour salt spray test, per ASTM® B117.

Anything built to last must start with the right foundation. Following that model, the foundation is comprised of 14-gauge, commercial-grade, full perimeter base rails (5) that integrate fork slots and rigging holes to save set-up time on the job site.

Easy Installation

The Renaissance line features a footprint that simplifies the replacement process by eliminating the need for a new curb adapter and being able to match inlet, outlet and electrical connections of the most common/industry-standard configurations.

Base Pan

The base pan is stamped to form a 7/8" flange around the supply and return cover, which eliminates the worry of water entering the conditioned space (6). All insulation is secured with both adhesive and mechanical fasteners, and all edges are hidden.

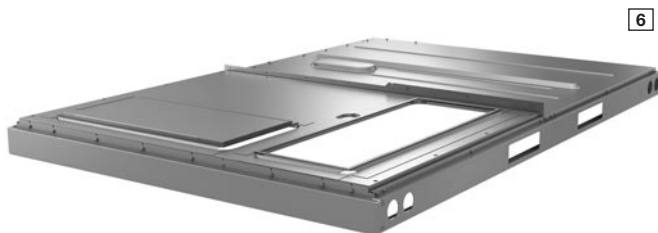

Drain Pan

The Qwik-Clean Drain Pan (7) is made from a composite material that resists the growth of harmful bacteria. With both side and center drain options, the drain pan slides out completely for easy cleaning. It also features a standard overflow switch.



Test Standards

During development, each unit was tested to U.L. 60335-2-40, AHRI 340-360 as well as other Friedrich-required reliability tests. Friedrich adheres to stringent ISO 9001 quality procedures, and each unit bears the U.L. and AHRI certification labels located on the unit nameplate. Contractors can be assured that when a Friedrich packaged unit arrives at the job, it is ready to go with a factory charge and quality checks.

Easy Access

All major compartments are easily accessible from the front of the unit: the electrical compartment, blower compartment, heating section, and outdoor section. Each compartment has mechanical fasteners. Panels are permanently embossed with the compartment name (e.g. control/filter access, blower access, and electric heat access). The filter compartment is accessed through a large, mechanically fastened panel. Information is readily available on the outside of the panel, with a nameplate that contains the model and serial numbers, electrical data, and other important unit information. Hinged access is available as an option for the electrical, blower, and filter compartments.

Charging Charts, Wiring Diagrams & Labels

The unit charging chart is located on the outside of the compressor access panel. Electrical wiring diagrams are found on the control box cover, which allows contractors to move them to more readable locations. The model and serial numbers are located on the right of the control box. Having this information on the inside means easier model identification for the life of the product. The production line quality test assurance label is also placed in this location (8).

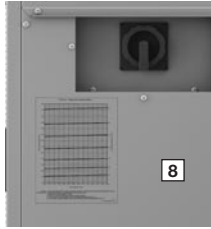

Filter Rack

Located within the filter compartment, the Qwik-Change Flex-Fit Rack (9) allows easy changeover between 2" and 4" standard size and readily available filters.



Blower Assembly

Inside the blower compartment, the Slide-Out Blower Assembly (10) is easy to access and remove. This makes servicing internal components such as blower motor, TXV, and MicroChannel coil much easier. The entire assembly slides out by removing the four 3/8" screws from the blower retention bracket.

The direct-drive backward curve blower (11) improves unit efficiency and expands the unit's airflow range capability. It effectively eliminates the need for separate options for low and high-static drive options because the blower's robust performance allows for a much wider static capability, up to 2". By referring to the airflow performance tables listed in the installation instructions, proper static pressure and CFM requirements can be dialed in.

The box plenum (patent-pending) is composed of fewer components than centrifugal housing blowers, reducing blower wear-and-tear, leading to a decreased chance of failure and less maintenance. The box plenum design also includes grab (ergonomic access) handles, (12) allowing easier and more secure removal of the blower assembly during service. This design also provides quiet and efficient airflow.

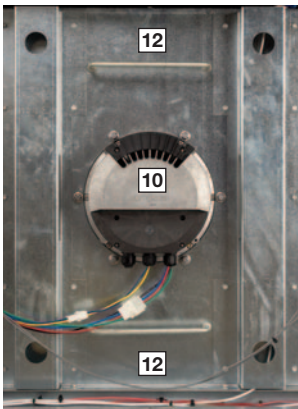

High and Low Pressure Switches & Freeze Sensor

High-pressure (13) and low-pressure (14) switches are standard. They are located in the outdoor section along with the low-ambient control (15). The standard freeze sensor (16), is clipped onto the suction line in the blower compartment. The low ambient control allows the compressor to operate down to 30°F degrees ambient temperature by cycling the outdoor fans on high-pressure. The high-pressure switch shuts off the compressors if pressures exceeding 610 PSIG are detected. The low-pressure switch shuts off the compressors if low-pressure is detected due to loss of charge. The advanced unitary controller reduces nuisance calls by only shutting off compressors after the fourth detection. The freeze sensor protects the compressor if the evaporator coil gets too cold (below freezing) due to low airflow.

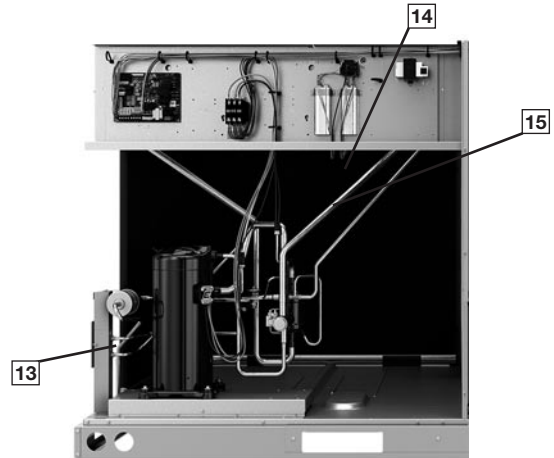

MicroChannel Evaporator & TXV

The MicroChannel Evaporator (17) is accessible through the blower compartment, and through the filter rack, to simplify cleaning. The evaporator uses MicroChannel technology for maximum heat transfer, light weight, fewer manually brazed connections and reduced refrigerant charge. The TXV metering device maintains superheat over a wide range of varying temperatures optimizing unit performance for all conditions.

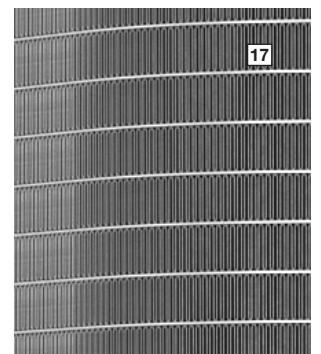

Control Box

Inside the control box (18), each electrical component is clearly labeled; that label matches the component to the wire diagram for ease of trouble shooting. All wiring is numbered on each end of the termination and is color-coded to match the wiring diagram (19). The Advanced Unitary Controller (20) incorporates a 22 character LCD display to easily navigate through the Human Machine Interface (HMI) and with easy-to-understand fault codes.

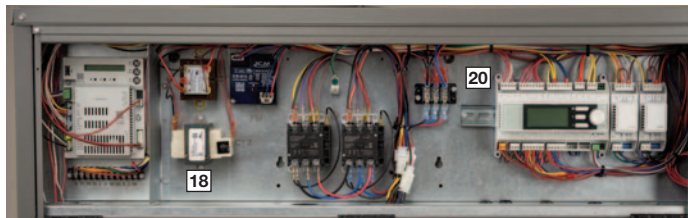

Advanced Unitary Controller

The standard advanced unitary controller system consisting of a rooftop unit controller, temperature sensors, pressure controls, allows real-time monitoring and between rooftop units. The controller is factory mounted and wired into the control panel. The controller is a solid-state, microprocessor-based control board that provides flexible control and extensive diagnostics for all unit functions. The controller, using proportional/integral control algorithms, performs specific unit functions that govern unit operation in response to zone conditions, system temperatures, ambient conditions, and electrical inputs. It features a 22 character by 5 line LCD display (21), three keys, and a push and scroll navigation wheel (22) for local configuration and direct diagnosis of the system. Features include a clogged filter switch (CFS), fan proving switch (FPS), return air temperature sensor (RAT), discharge air temperature sensor (DAT), and outdoor air temperature sensor (OAT), and freeze sensors (FS).



The RHPDYC with the advanced unitary controller is specifically designed to be applied in three distinct applications:

- 1. BACnet Communication** — The RHPDYC is compatible with a third party building management system that supports the BACnet Application Specific Controller device profile, via standard BACnet IP or BACnet MS/TP communication. The controller communicated with either BACnet IP or BACnet MS/TP without additional communication modules. Communication with a BACnet application can be easily set up by navigating through the controller menu tree.
- 2. 24VAC Thermostat Compatibility** — The RHPDYC is compatible with a programmable 24 volt thermostat. Connections are made via a dedicated 24VAC terminal block for easier field installation. Extensive unit status and diagnostics are displayed on the LCD screen.
- 3. Zone Sensor Compatibility** — The RHPDYC is compatible with the QMX3.P74 Zone Sensor. The zone sensor includes temperature, CO₂, and humidity sensing with built in setpoint adjustment. To configure the zone sensor, navigate to the Zone Sensor menu in the controller menu tree. Extensive unit status and diagnostics are displayed on the controller LCD screen.

Convenience Outlet

For added convenience in the field, factory-installed option of non-powered convenience outlet (23) is available. Low and high voltage can enter from the side or through the base. Low-voltage connections are made through the low-voltage terminal strip. For ease of access, the U.L.-required low voltage barrier can be temporarily removed for low-voltage termination and then reinstalled. The high-voltage connection is terminated at the number 1 compressor contactor.

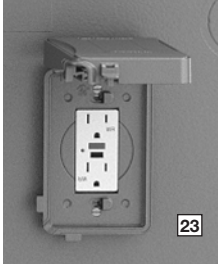

External Lockable Gauge Ports

To the right left of the compressor compartment are the externally mounted lockable gauge ports. They are permanently identified by embossed lettering that identifies the compressor circuit, high-pressure connection, (24) and low-pressure connection (25). Because the gauge ports are mounted externally, an accurate diagnostic of system operation can be performed without removing access panels. Brass caps on the Schrader fitting ensure the gauge parts are leak proof.

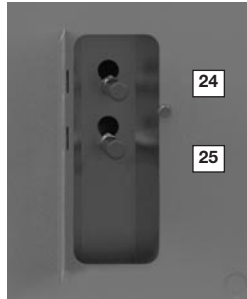

Compressor

The compressor compartment houses the heartbeat of the unit. The scroll compressor (26) is known for its long life and for reliable, quiet, and efficient operation. The suction and discharge lines are designed with shock loops (27) to absorb the strain and stress that the starting torque, steady state operation, and shut-down cycle impose on the refrigerant tubing. The units have a set of tandem scroll compressors—one two-stage compressor and one single-stage compressor—that allows for three stages of efficient cooling or heating operation. Each unit comes standard with a filter dryer.



Condenser Fans

The condenser fan motor and motor controller (28) can easily be accessed and maintained through the top of the unit. A down-mount fan provides corrosion protection and removal. The polarized plug connection allows the motor and motor controller to be changed quickly. The computational head is remotely mounted on the top panel to prevent exposure to weather and moisture.



MicroChannel Condenser Technology

The outdoor coil uses the latest MicroChannel technology (29) for the most effective method of heat transfer. The outdoor coil is protected by optional louvered panels, which allow unobstructed airflow while protecting the unit from both the environment and vandalism.

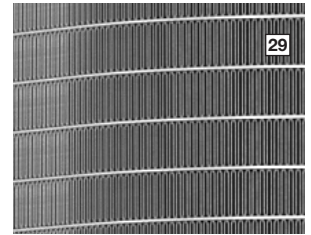

Coil Coating

Every unit offers the option of factory-applied E-Coat condenser coating (30) that delivers superior corrosion resistance for outdoor coils to operate in the harshest of environments.

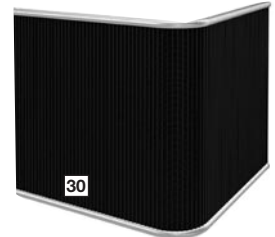

Economizer and Dampers

Each unit is designed for both down flow or horizontal applications (31) for job configuration flexibility. The return air compartment can also contain an economizer. Each unit is pre-wired for the economizer to allow quick, plug-in installation. Available as a factory-installed option, the economizer provides free cooling when outdoor conditions are suitable and also provides fresh air to meet local requirements. It comes standard with single enthalpy controls, which can be upgraded to dual enthalpy easily in the field. The economizer control has a minimum position set point, an outdoor-air set point, a mixed-air set point, and a CO₂ set point. Barometric relief is standard on all economizers.

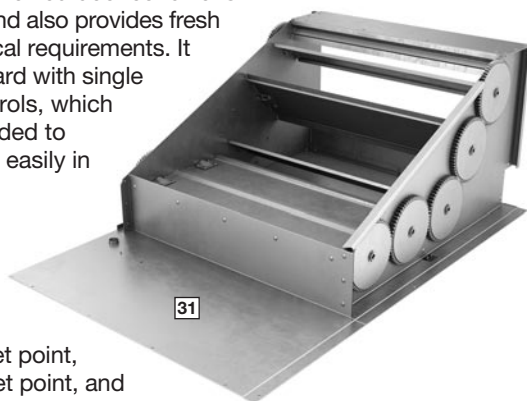

Power Exhaust is easily field-installed. The power exhaust is housed in the barometric relief opening and is easily slipped in with a plugin assembly. The wire harness to the economizer also has accommodations for a smoke detector.

The damper minimum position, actual damper position, power exhaust on/off set point, mixed air temperature limit set point, and Demand Controlled Ventilation (DCV) set point can be read and adjusted at the unit controller display or remotely through a network connection. The Space CO₂ level, mixed air temperature, and Economizer Status (free cooling available, single or dual enthalpy) can be read at the unit controller display or remotely through a network connection. Economizer faults will trigger a network alarm and can be read at the unit controller display or remotely through a network connection.

Roofcurb

The Friedrich roofcurb (32) is made for tool-less assembly at the jobsite by engaging tabs in slots of adjacent curb sides, which makes the assembly process quick and easy.



Refrigerant Leak Detection

In the event of a detected refrigerant leak, the refrigerant leak detection sensor will trigger the mitigation procedure that shuts off the compressor(s) and turns on the indoor blower motor.

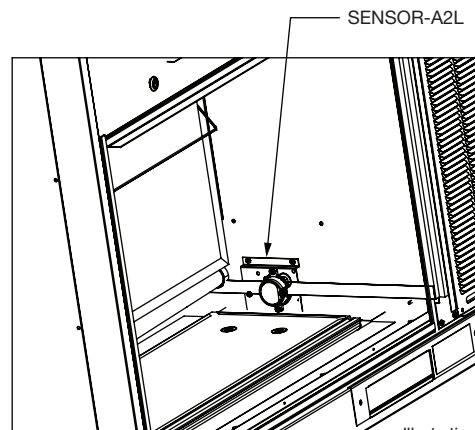

If a field-installed vertical economizer will be installed during the unit installation, the A2L leak detection sensor must be relocated as shown below. For more information, refer to the unit installation and Operation Manual.

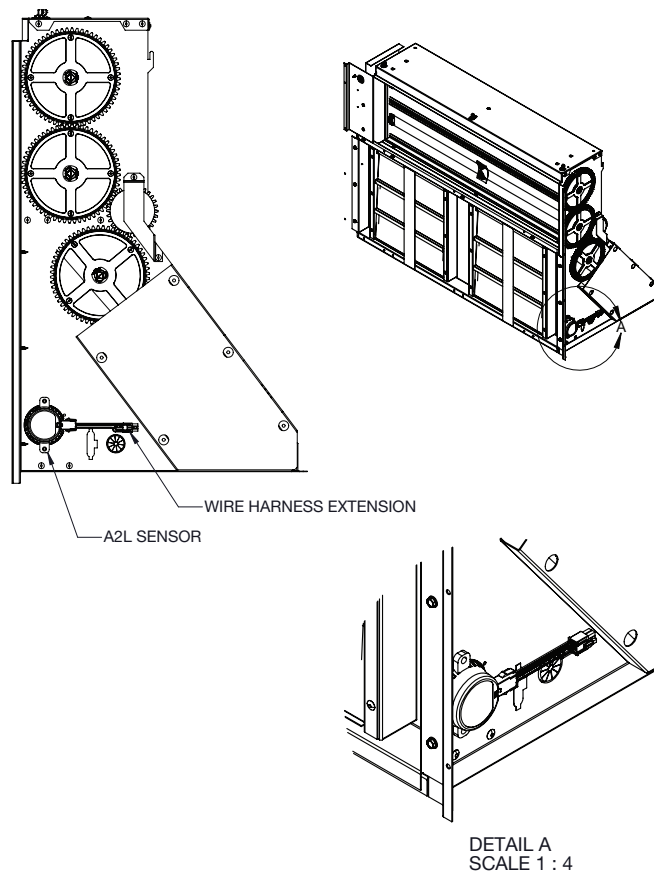

R HP D Y C 090 A C K 00 0 E A ***
1 23 4 5 6 789 10 11 12 13 14 15 16 17 18 19 20

1—Brand

R = Friedrich

2, 3—Unit Type

HP = Packaged Heat Pump

4—Cabinet Type

D = Medium Commercial

5—Refrigerant

Y = R-454B

6—Efficiency Level

C = High Efficiency

7, 8, 9—Capacity

078 = 6.5 Ton

090 = 7.5 Ton

102 = 8.5 Ton

120 = 10 Ton

10—Major Series

A = 1st Design

11—Voltage

C = 3 PH, 208-230V, 60 Hz

D = 3 PH, 460V, 60 Hz

12—Drive

K = Direct Drive Standard
Static (0-10V)

13, 14—Heat Capacity

00 = No Heat

10 = 10 kW

15 = 15 kW

20 = 20 kW

30 = 30 kW

40 = 40 kW

15—Heat Configuration

0 = No stages

1 = 1 stage

2 = 2 stage

16—Control

E = Advanced Unitary
Controller

17—Minor Series

A = 1st Design

18, 19, 20—Option Code

See next page

FACTORY-INSTALLED OPTION CODES FOR RHPDYC (6.5–10 TON)

18				19			20				
LV = Louver protection				LF = Low Ambient & Freeze Stat			EC = Downflow Economizer				
HA = Hinged Access				NP = Non-powered Convenience Outlet			SS = Supply Smoke Detector				
CC = Coil Coating							RS = Return Smoke Detector				
Option code character highlighted below											
A	None			A	None			0	None		
B	LV			B	LF			1	EC		
C	HA			C	NP			2	RS		
D	LV	HA		D	LF	NP		3	EC	RS	
E	LV	CC						4	SS	RS	
F	LV	HA	CC					5	EC	SS	RS

Instructions for Factory-Installed Option(s) Selection

Note: Three characters following the model number will be utilized to designate a factory-installed option or combination of options. If no factory option(s) is required, “AA0” follows the model number.

- **Step 1:** In the table above, based on the desired features, choose option code character from highlighted options on the left side under the number 18. For example, the option code character “E” has Louver protection and Coil Coating.
- **Step 2:** In the table above, based on the desired features, choose option code character from highlighted options on the left side under the number 19. For example, the option code character “D” has Low Ambient / Freeze Stat and Non-powered convenience outlet.
- **Step 3:** In the table above, based on the desired features, choose option code character from highlighted options on the left side under the number 20. For example, the option code character “3” has Economizer and Return Smoke.
- The resulting option code from examples above is: “ED3”
- **Step 4:** Add your option code selection to the end of model number

◦ Example: RHPDYC078ACK150EA ED3 = RHPDYC078ACK150EAED3

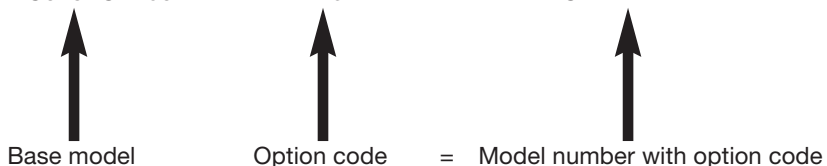

To select an RHPDYC Cooling and Heating unit to meet a job requirement, follow this procedure, with example, using data supplied in this specification sheet.

1. DETERMINE COOLING AND HEATING REQUIREMENTS AND SPECIFIC OPERATING CONDITIONS FROM PLANS AND SPECS.

Example:

Voltage—	230 V – 3 Phase – 60 Hz
Total Cooling Capacity—	118,000 Btu/h [34.57 kW]
Sensible Cooling Capacity—	79,600 Btu/h [23.32 kW]
Heating Capacity—	150,000 Btu/h [40 kW]
*Condenser Entering Air—	95°F [35.0°C] DB
*Evaporator Mixed Air Entering—	65°F [18.3°C] WB 78°F [25.6°C] DB
*Indoor Air Flow (vertical)—	4000 CFM [2265 L/s]
*External Static Pressure—	0.40 in. WG [.10 kPa]

2. SELECT UNIT TO MEET COOLING REQUIREMENTS.

Since total cooling is within the range of a nominal 10 ton [35.1 kW] unit, enter cooling performance table at 95°F [35.0°C] DB condenser inlet air. Interpolate between 63°F [17.2°C] WB and 67°F [19.4°C] to determine total and sensible capacity for 65°F [18.3°C] WB evaporator inlet air at 4000 CFM [2265 L/s] indoor air flow (table basis):

Total Cooling Capacity = 110,500 Btu/h [32.4 kW] Sensible Cooling Capacity = 92,650 Btu/h [27.2 kW]

Use formula $[1.10 \times \text{CFM} \times (1 - \text{DR}) \times (\text{dbE} - 80)]$ in note to determine sensible capacity at 80°F [26.7°C] DB evaporator entering air:

$92,650 + (1.10 \times 4,000 \times (1 - 0.1) \times (78 - 80))$
Sensible Cooling Capacity = 84,730 Btu/h [24.8 kW]

3. DETERMINE BLOWER SPEED AND WATTS TO MEET SYSTEM DESIGN.

Enter Indoor Blower performance table at 4000 CFM [2265 L/s]. Total ESP (external static pressure) per the spec of 0.40 in. WG [.10 kPa] includes the system duct and grilles:

RPM = 1205
WATTS = 895
% VDC = 47.0

4. CALCULATE INDOOR BLOWER Btu/h HEAT EFFECT FROM MOTOR WATTS, STEP 3.

Assuming an average of 85% motor efficiency, determine the amount of heat generated by the blower motor at the specified CFM and ESP by dividing the watts used by the motor efficiency and solving for the difference. Convert this value from watts to Btu/h, multiplying by 3.41 Btu/h/Watt

Watts = 895

Avg. Motor Efficiency = 85%

Watts – Watts x 3.41 0.85

= $[(895/0.85)-895] \times 3.41 = 540 \text{ Btu/h [158.2 kW]}$

5. CALCULATE NET COOLING CAPACITIES, EQUAL TO GROSS CAPACITY, STEP 3, MINUS INDOOR BLOWER MOTOR HEAT.

Net Total Capacity = 110,500 – 540 =
109,960 Btu/h [32.3 kW]

Net Sensible Capacity = 92,650 – 540 =
92,110 Btu/h [27.0 kW]

6. CHOOSE MODEL RHPDYC120ACK.

***NOTE:** These operating conditions are typical of a commercial application in a 95°F/79°F [35°C/26°C] design area with indoor design of 76°F [24°C] DB and 50% RH and 10% ventilation air, with the unit roof mounted and centered on the zone it conditions by ducts.

[] Designates Metric Conversions

GENERAL DATA—RHPDYC MODELS—6.5–10 TON

Model RHPDYC Series	078ACK	078ADK	090ACK	090ADK
Cooling Performance^A				CONTINUED →
Nominal Cooling Capacity Btu/h [kW]	78,000 [22.85]	78,000 [22.85]	90,000 [26.37]	90,000 [26.37]
EER / IEER ^B	12.0/17.6	12.0/17.6	12.0/17.6	12.0/17.6
Nominal CFM/AHRI Rated CFM [L/s]	2,400/2,240 [1,133/1,057]	2,400/2,240 [1,133/1,057]	2,800/2,550 [1,321/1,203]	2,800/2,550 [1,321/1,203]
AHRI Net Cooling Capacity Btu/h [kW]	74,000 [21.46]	74,000 [21.46]	86,000 [24.94]	86,000 [24.94]
Net Sensible Capacity Btu/h [kW]	59,200 [17.17]	59,200 [17.17]	68,800 [19.95]	68,800 [19.95]
Net Latent Capacity Btu/h [kW]	14,800 [4.29]	14,800 [4.29]	17,200 [4.99]	17,200 [4.99]
Net System Power [kW]	6.2	6.2	7.2	7.2
Heating Performance (Heat Pumps)				
High Temp. Btu/h [kW] Rating @ 47°F	74,000 [21.68]	74,000 [21.68]	86,000 [25.20]	86,000 [25.20]
System Power kW/COP @ 47°F	6.02/3.60	6.02/3.60	7.00/3.60	7.00/3.60
Low Temp. Btu/h [kW] Rating @ 17°F	44,500 [13.04]	44,500 [13.04]	55,000 [16.12]	55,000 [16.12]
System Power kW/COP @ 17°F	5.22/2.50	5.22/2.50	6.45/2.50	6.45/2.50
Compressor				
No. / Stage / Type	2 / 3 / Tandem scroll	2 / 3 / Tandem scroll	2 / 3 / Tandem scroll	2 / 3 / Tandem scroll
Outdoor Sound Rating (dB)^C	87	87	88	88
Outdoor Coil - Fin Type	Louvered	Louvered	Louvered	Louvered
Tube Type	MicroChannel	MicroChannel	MicroChannel	MicroChannel
MicroChannel: Depth in. [mm]	1.00 [25.40]	1.00 [25.40]	1.26 [32.00]	1.26 [32.00]
Face Area sq. ft. [sq. m]	22.4 [2.08]	22.4 [2.08]	28.8 [2.68]	28.8 [2.68]
Rows / FPI [FPcm]	1 / 16 [6]	1 / 16 [6]	1 / 16 [6]	1 / 16 [6]
Indoor Coil - Fin Type	Louvered	Louvered	Louvered	Louvered
Tube Type	MicroChannel	MicroChannel	MicroChannel	MicroChannel
MicroChannel: Depth in. [mm]	1.26 [32.00]	1.26 [32.00]	1.26 [32.00]	1.26 [32.00]
Face Area sq. ft. [sq. m]	11.3 [1.05]	11.3 [1.05]	13.9 [1.29]	13.9 [1.29]
Rows / FPI [FPcm]	1 / 20 [8]	1 / 20 [8]	1 / 20 [8]	1 / 20 [8]
Refrigerant Control	TXV	TXV	TXV	TXV
Drain Connection No./Size in. [mm]	1 / 0.750 [19.05]	1 / 0.750 [19.05]	1 / 0.750 [19.05]	1 / 0.750 [19.05]
Outdoor Fan - Type	ECM / Propeller	ECM / Propeller	ECM / Propeller	ECM / Propeller
No. Used/Diameter in. [mm]	2/24.0 [609.6]	2/24.0 [609.6]	2/24.0 [609.6]	2/24.0 [609.6]
Drive Type/No. Speeds	Direct / Multiple	Direct / Multiple	Direct / Multiple	Direct / Multiple
CFM [L/s]	8,000 [3,776]	8,000 [3,776]	8,000 [3,776]	8,000 [3,776]
No. Motors at HP	2 at 1/2	2 at 1/2	2 at 1/2	2 at 1/2
Motor RPM	1,200	1,140	1,200	1,140
Indoor Fan - Type	BC Centrifugal	BC Centrifugal	BC Centrifugal	BC Centrifugal
No. Used/Wheel Diameter x Width in. [mm]	1/23x11 [585x282]	1/23x11 [585x282]	1/23x11 [585x282]	1/23x11 [585x282]
Drive Type	Direct	Direct	Direct	Direct
No. Speeds	Multiple	Multiple	Multiple	Multiple
No. Motors	1	1	1	1
Motor HP	5	5	5	5
Motor RPM	1,940	2,000	1,940	2,000
Motor Frame Size	150	150	150	150
Filter - Type	Disposable	Disposable	Disposable	Disposable
Furnished	Yes	Yes	Yes	Yes
(NO.) Size Recommended in. [mm x mm x mm]	(4) 2x20x20 [50x508x508]	(4) 2x20x20 [50x508x508]	(4) 2x25x20 [50x635x508]	(4) 2x25x20 [50x635x508]
Refrigerant Charge Oz. [g]	202.0 [5,726.6]	202.0 [5,726.6]	214.0 [6,066.8]	214.0 [6,066.8]
Weights				
Net Weight lbs. [kg]	869 [394]	869 [394]	1,009 [458]	1,009 [458]
Ship Weight lbs. [kg]	908 [412]	908 [412]	1,048 [475]	1,048 [475]

See Page 15 for Notes.

[] Designates Metric Conversions

GENERAL DATA—RHPDYC MODELS—6.5–10 TON

Model RHPDYC Series	102ACK	102ADK	120ACK	120ADK
Cooling Performance^A				CONTINUED →
Nominal Cooling Capacity Btu/h [kW]	102,000 [29.89]	102,000 [29.89]	120,000 [35.16]	120,000 [35.16]
EER / IEER ^B	12.0/17.6	12.0/17.6	12.0/17.6	12.0/17.6
Nominal CFM/AHRI Rated CFM [L/s]	3,200/3,350 [1,510/1,581]	3,200/3,350 [1,510/1,581]	4,000/4,750 [1,888/2,242]	4,000/4,750 [1,888/2,242]
AHRI Net Cooling Capacity Btu/h [kW]	96,000 [27.84]	96,000 [27.84]	114,000 [33.06]	114,000 [33.06]
Net Sensible Capacity Btu/h [kW]	76,800 [22.27]	76,800 [22.27]	91,200 [26.45]	91,200 [26.45]
Net Latent Capacity Btu/h [kW]	19,200 [5.57]	19,200 [5.57]	22,800 [6.61]	22,800 [6.61]
Net System Power [kW]	8.0	8.0	9.5	9.5
Heating Performance (Heat Pumps)				
High Temp. Btu/h [kW] Rating @ 47°F	96,000 [28.13]	96,000 [28.13]	108,000 [31.64]	108,000 [31.64]
System Power kW/COP @ 47°F	7.81/3.60	7.81/3.60	8.79/3.60	8.79/3.60
Low Temp. Btu/h [kW] Rating @ 17°F	62,000 [18.17]	62,000 [18.17]	66,000 [19.34]	66,000 [19.34]
System Power kW/COP @ 17°F	7.27/2.50	7.27/2.50	7.74/2.50	7.74/2.50
Compressor				
No. / Stage / Type	2 / 3 / Tandem scroll	2 / 3 / Tandem scroll	2 / 3 / Tandem scroll	2 / 3 / Tandem scroll
Outdoor Sound Rating (dB)^C	88	88	81	81
Outdoor Coil - Fin Type	Louvered	Louvered	Louvered	Louvered
Tube Type	MicroChannel	MicroChannel	MicroChannel	MicroChannel
MicroChannel: Depth in. [mm]	1.26 [32.00]	1.26 [32.00]	1.26 [32.00]	1.26 [32.00]
Face Area sq. ft. [sq. m]	28.8 [2.68]	28.8 [2.68]	28.8 [2.68]	28.8 [2.68]
Rows / FPI [FPcm]	1 / 16 [6]	1 / 16 [6]	1 / 16 [6]	1 / 16 [6]
Indoor Coil - Fin Type	Louvered	Louvered	Louvered	Louvered
Tube Type	MicroChannel	MicroChannel	MicroChannel	MicroChannel
MicroChannel: Depth in. [mm]	1.26 [32.00]	1.26 [32.00]	1.26 [32.00]	1.26 [32.00]
Face Area sq. ft. [sq. m]	13.9 [1.29]	13.9 [1.29]	13.9 [1.29]	13.9 [1.29]
Rows / FPI [FPcm]	1 / 20 [8]	1 / 20 [8]	1 / 20 [8]	1 / 20 [8]
Refrigerant Control	TXV	TXV	TXV	TXV
Drain Connection No./Size in. [mm]	1 / 0.750 [19.05]	1 / 0.750 [19.05]	1 / 0.750 [19.05]	1 / 0.750 [19.05]
Outdoor Fan - Type	ECM / Propeller	ECM / Propeller	ECM / Propeller	ECM / Propeller
No. Used/Diameter in. [mm]	2/24.0 [609.6]	2/24.0 [609.6]	2/24.0 [609.6]	2/24.0 [609.6]
Drive Type/No. Speeds	Direct / Multiple	Direct / Multiple	Direct / Multiple	Direct / Multiple
CFM [L/s]	8,000 [3,776]	8,000 [3,776]	8,000 [3,776]	8,000 [3,776]
No. Motors at HP	2 at 1/2	2 at 1/2	2 at 1/2	2 at 1/2
Motor RPM	1,200	1,140	1,200	1,140
Indoor Fan - Type	BC Centrifugal	BC Centrifugal	BC Centrifugal	BC Centrifugal
No. Used/Wheel Diameter x Width in. [mm]	1/23x11 [585x282]	1/23x11 [585x282]	1/23x11 [585x282]	1/23x11 [585x282]
Drive Type	Direct	Direct	Direct	Direct
No. Speeds	Multiple	Multiple	Multiple	Multiple
No. Motors	1	1	1	1
Motor HP	5	5	5	5
Motor RPM	1,940	2,000	1,940	2,000
Motor Frame Size	150	150	150	150
Filter - Type	Disposable	Disposable	Disposable	Disposable
Furnished	Yes	Yes	Yes	Yes
(NO.) Size Recommended in. [mm x mm x mm]	(1) 2x25x20 [50x635x508]	(1) 2x25x20 [50x635x508]	(4) 2x25x20 [50x635x508]	(4) 2x25x20 [50x635x508]
Refrigerant Charge Oz. [g]	204.0 [5,783.3]	204.0 [5,783.3]	219.0 [6,208.5]	219.0 [6,208.5]
Weights				
Net Weight lbs. [kg]	1,009 [458]	1,009 [458]	1,009 [458]	1,009 [458]
Ship Weight lbs. [kg]	1,048 [475]	1,048 [475]	1,048 [475]	1,048 [475]

See Page 15 for Notes.

[] Designates Metric Conversions

NOTES:

- A. Cooling Performance is rated at 95°F ambient, 80°F entering dry bulb, 67°F entering wet bulb. Gross capacity does not include the effect of fan motor heat. AHRI capacity is net and includes the effect of fan motor heat. Units are suitable for operation to ±20% of nominal CFM. Units are certified in accordance with the Unitary Air Conditioner Equipment certification program, which is based on AHRI Standard 340/360.
- B. EER and Integrated Energy Efficiency (IEER) are rated in accordance with AHRI Standard 340/360 and DOE test standards.
- C. Outdoor Sound Rating shown is tested in accordance with AHRI Standard 270.

[] Designates Metric Conversions

WEIGHTED SOUND POWER LEVEL (dBA)

MODEL	STD. RATING (dBA)	FREQUENCY (Hz)						
		125	250	500	1000	2000	4000	8000
RHPDYC078	83.9	64.2	70.0	73.9	73.8	71.0	66.2	60.2
RHPDYC090	89.2	65.0	70.3	80.5	78.8	75.8	72.4	67.0
RHPDYC102	88.8	63.6	74.3	79.6	78.5	75.6	70.8	64.2
RHPDYC120	89.5	81.2	74.6	82.6	78.6	74.3	70.0	65.6

COOLING PERFORMANCE DATA – RHPDYC078

		ENTERING INDOOR AIR @ 80°F [26.7°C] dbE ①									
		wbE	71°F [21.7°C]			67°F [19.4°C]			63°F [17.2°C]		
		CFM [L/s]	3125 [1475]	2250 [1062]	2075 [979]	3125 [1475]	2250 [1062]	2075 [979]	3125 [1475]	2250 [1062]	2075 [979]
		DR ①	.05	.09	.12	.05	.09	.12	.05	.09	.12
O U T D O O R D R Y B U L B T E M P E R A T U R E ° F [° C]	75 [23.9]	Total kBtu/h [kW] Sens kBtu/h [kW] Power	103.3 [30.3] 61.2 [17.9] 5.5	96.5 [28.3] 51.8 [15.2] 5.4	95.2 [27.9] 49.9 [14.6] 5.3	96.1 [28.2] 71.4 [20.9] 5.6	89.7 [26.3] 60.4 [17.7] 5.4	88.5 [25.9] 58.2 [17.1] 5.4	90.1 [26.4] 81.5 [23.9] 5.5	84.2 [24.7] 69.0 [20.2] 5.3	83.0 [24.3] 66.5 [19.5] 5.3
	80 [26.7]	Total kBtu/h [kW] Sens kBtu/h [kW] Power	101.7 [29.8] 60.4 [17.7] 5.9	95.0 [27.8] 51.1 [15.0] 5.7	93.6 [27.4] 49.3 [14.4] 5.6	94.4 [27.7] 70.6 [20.7] 5.9	88.2 [25.8] 59.7 [17.5] 5.7	87.0 [25.5] 57.6 [16.9] 5.7	88.5 [25.9] 80.7 [23.7] 5.8	82.6 [24.2] 68.3 [20.0] 5.6	81.4 [23.9] 65.8 [19.3] 5.6
	85 [29.4]	Total kBtu/h [kW] Sens kBtu/h [kW] Power	99.8 [29.2] 59.5 [17.4] 6.2	93.2 [27.3] 50.4 [14.8] 6.0	91.9 [26.9] 48.5 [14.2] 5.9	92.5 [27.1] 69.7 [20.4] 6.2	86.4 [25.3] 59.0 [17.3] 6.0	85.2 [25.0] 56.8 [16.6] 6.0	86.6 [25.4] 79.8 [23.4] 6.1	80.8 [23.7] 67.5 [19.8] 5.9	79.7 [23.4] 65.1 [19.1] 5.9
	90 [32.2]	Total kBtu/h [kW] Sens kBtu/h [kW] Power	97.6 [28.6] 58.4 [17.1] 6.5	91.2 [26.7] 49.5 [14.5] 6.3	89.9 [26.3] 47.7 [14] 6.2	90.4 [26.5] 68.6 [20.1] 6.5	84.4 [24.7] 58.1 [17.0] 6.3	83.2 [24.4] 55.9 [16.4] 6.3	84.4 [24.7] 78.7 [23.1] 6.5	78.8 [23.1] 66.6 [19.5] 6.2	77.7 [22.8] 64.2 [18.8] 6.2
	95 [35]	Total kBtu/h [kW] Sens kBtu/h [kW] Power	95.2 [27.9] 57.2 [16.8] 6.8	88.9 [26.1] 48.4 [14.2] 6.6	87.7 [25.7] 46.7 [13.7] 6.5	88.0 [25.8] 67.4 [19.8] 6.8	82.2 [24.1] 57.0 [16.7] 6.6	81.0 [23.7] 55.0 [16.1] 6.6	82.0 [24.0] 77.5 [22.7] 6.8	76.6 [22.5] 65.6 [19.2] 6.6	75.5 [22.1] 63.2 [18.5] 6.5
	100 [37.8]	Total kBtu/h [kW] Sens kBtu/h [kW] Power	92.6 [27.1] 55.9 [16.4] 7.1	86.5 [25.4] 47.3 [13.9] 6.9	85.2 [25.0] 45.6 [13.4] 6.8	85.3 [25.0] 66.0 [19.3] 7.2	79.7 [23.4] 55.9 [16.4] 6.9	78.5 [23.0] 53.9 [15.8] 6.9	79.3 [23.2] 76.2 [22.3] 7.1	74.1 [21.7] 64.5 [18.9] 6.9	73.0 [21.4] 62.1 [18.2] 6.8
	105 [40.6]	Total kBtu/h [kW] Sens kBtu/h [kW] Power	89.7 [26.3] 54.4 [15.9] 7.4	83.7 [24.5] 46.1 [13.5] 7.2	82.6 [24.2] 44.4 [13.0] 7.1	82.4 [24.2] 64.6 [18.9] 7.5	77.0 [22.6] 54.7 [16.0] 7.2	75.9 [22.2] 52.7 [15.4] 7.2	76.4 [22.4] 74.7 [21.9] 7.4	71.4 [20.9] 63.2 [18.5] 7.2	70.4 [20.6] 60.9 [17.8] 7.1
	110 [43.3]	Total kBtu/h [kW] Sens kBtu/h [kW] Power	86.5 [25.4] 52.8 [15.5] 7.8	80.8 [23.7] 44.7 [13.1] 7.5	79.6 [23.3] 43.1 [12.6] 7.4	79.2 [23.2] 63.0 [18.5] 7.8	74.0 [21.7] 53.3 [15.6] 7.5	73.0 [21.4] 51.4 [15.1] 7.5	73.3 [21.5] 73.1 [21.4] 7.7	68.4 [20.0] 61.9 [18.1] 7.5	67.5 [19.8] 59.6 [17.5] 7.4
	115 [46.1]	Total kBtu/h [kW] Sens kBtu/h [kW] Power	83.1 [24.4] 51.1 [15.0] 8.1	77.6 [22.7] 43.2 [12.7] 7.8	76.5 [22.4] 41.7 [12.2] 7.7	75.8 [22.2] 61.2 [17.9] 8.1	70.8 [20.8] 51.8 [15.2] 7.8	69.8 [20.5] 49.9 [14.6] 7.8	69.9 [20.5] 69.9 [20.5] 8.0	65.2 [19.1] 60.4 [17.7] 7.8	64.3 [18.8] 58.2 [17.1] 7.7
	120 [48.9]	Total kBtu/h [kW] Sens kBtu/h [kW] Power	79.4 [23.3] 49.2 [14.4] 8.4	74.2 [21.7] 41.6 [12.2] 8.1	73.1 [21.4] 40.1 [11.8] 8.1	72.2 [21.2] 59.3 [17.4] 8.4	67.4 [19.8] 50.2 [14.7] 8.1	66.5 [19.5] 48.4 [14.2] 8.1	66.2 [19.4] 66.2 [19.4] 8.4	61.8 [18.1] 58.8 [17.2] 8.1	60.9 [17.8] 56.7 [16.6] 8.0
125 [51.7]	Total kBtu/h [kW] Sens kBtu/h [kW] Power	75.5 [22.1] 47.2 [13.8] 8.7	70.5 [20.7] 39.9 [11.7] 8.4	69.5 [20.4] 38.5 [11.3] 8.4	68.3 [20.0] 57.3 [16.8] 8.7	63.8 [18.7] 48.5 [14.2] 8.4	62.9 [18.4] 46.8 [13.7] 8.4	62.3 [18.3] 62.3 [18.3] 8.7	58.2 [17.1] 57.1 [16.7] 8.4	57.3 [16.8] 55.0 [16.1] 8.3	

DR —Depression ratio
dbE —Entering air dry bulb
wbE—Entering air wet bulb

Total —Total capacity x 1000 Btu/h
Sens —Sensible capacity x 1000 Btu/h
Power —kW input

NOTES: ① When the entering air dry bulb is other than 80°F [27°C], adjust the sensible capacity from the table by adding [1.10 x CFM x (1 – DR) x (dbE – 80)].

[] Designates Metric Conversions

COOLING PERFORMANCE DATA—RHPDYC090

ENTERING INDOOR AIR @ 80°F [26.7°C] dbE ①											
wbE		71°F [21.7°C]			67°F [19.4°C]			63°F [17.2°C]			
CFM [L/s]		3600 [1699]	2550 [1203]	2400 [1133]	3600 [1699]	2550 [1203]	2400 [1133]	3600 [1699]	2550 [1203]	2400 [1133]	
DR ①		.05	.09	.12	.05	.09	.12	.05	.09	.12	
OUTDOOR DRY BULB TEMPERATURE °F [°C]	75 [23.9]	Total kBtu/h [kW]	118.5 [34.7]	110.2 [32.3]	109.0 [31.9]	111.5 [32.7]	103.7 [30.4]	102.6 [30.1]	104.5 [30.6]	97.2 [28.5]	96.2 [28.2]
		Sens kBtu/h [kW]	71.6 [21.0]	60.1 [17.6]	58.4 [17.1]	83.7 [24.5]	70.2 [20.6]	68.2 [20]	95.7 [28.0]	80.3 [23.5]	78.1 [22.9]
		Power	6.0	5.8	5.8	6.0	5.8	5.8	6.0	5.8	5.7
	80 [26.7]	Total kBtu/h [kW]	116.3 [34.1]	108.2 [31.7]	107.0 [31.4]	109.3 [32.0]	101.7 [29.8]	100.6 [29.5]	102.3 [30.0]	95.2 [27.9]	94.2 [27.6]
		Sens kBtu/h [kW]	70.6 [20.7]	59.2 [17.4]	57.6 [16.9]	82.7 [24.2]	69.3 [20.3]	67.4 [19.8]	94.7 [27.8]	79.4 [23.3]	77.3 [22.7]
		Power	6.4	6.1	6.1	6.3	6.1	6.1	6.3	6.1	6.1
	85 [29.4]	Total kBtu/h [kW]	114.1 [33.4]	106.2 [31.1]	105.1 [30.8]	107.1 [31.4]	99.7 [29.2]	98.6 [28.9]	100.1 [29.3]	93.2 [27.3]	92.2 [27.0]
		Sens kBtu/h [kW]	69.6 [20.4]	58.4 [17.1]	56.8 [16.6]	81.7 [23.9]	68.5 [20.1]	66.6 [19.5]	93.7 [27.5]	78.6 [23.0]	76.4 [22.4]
		Power	6.7	6.5	6.5	6.7	6.5	6.4	6.7	6.5	6.4
	90 [32.2]	Total kBtu/h [kW]	112.0 [32.8]	104.2 [30.5]	103.1 [30.2]	105.0 [30.8]	97.7 [28.6]	96.6 [28.3]	98.0 [28.7]	91.2 [26.7]	90.2 [26.4]
		Sens kBtu/h [kW]	68.6 [20.1]	57.6 [16.9]	56.0 [16.4]	80.7 [23.7]	67.7 [19.8]	65.8 [19.3]	92.7 [27.2]	77.8 [22.8]	75.6 [22.2]
		Power	7.1	6.9	6.8	7.1	6.9	6.8	7.1	6.8	6.8
95 [35]	Total kBtu/h [kW]	109.8 [32.2]	102.2 [30.0]	101.1 [29.6]	102.8 [30.1]	95.7 [28.0]	94.6 [27.7]	95.8 [28.1]	89.2 [26.1]	88.2 [25.8]	
	Sens kBtu/h [kW]	67.6 [19.8]	56.7 [16.6]	55.2 [16.2]	79.7 [23.4]	66.8 [19.6]	65.0 [19.1]	91.7 [26.9]	76.9 [22.5]	74.8 [21.9]	
	Power	7.6	7.3	7.3	7.5	7.3	7.2	7.5	7.3	7.2	
100 [37.8]	Total kBtu/h [kW]	107.7 [31.6]	100.2 [29.4]	99.1 [29.0]	100.7 [29.5]	93.7 [27.5]	92.7 [27.2]	93.7 [27.5]	87.1 [25.5]	86.2 [25.3]	
	Sens kBtu/h [kW]	66.6 [19.5]	55.9 [16.4]	54.4 [15.9]	78.7 [23.1]	66.0 [19.3]	64.2 [18.8]	90.7 [26.6]	76.1 [22.3]	74.0 [21.7]	
	Power	8.0	7.7	7.7	8	7.7	7.7	8.0	7.7	7.7	
105 [40.6]	Total kBtu/h [kW]	105.5 [30.9]	98.2 [28.8]	97.1 [28.5]	98.5 [28.9]	91.6 [26.8]	90.7 [26.6]	91.5 [26.8]	85.1 [24.9]	84.2 [24.7]	
	Sens kBtu/h [kW]	65.6 [19.2]	55.1 [16.1]	53.5 [15.7]	77.7 [22.8]	65.2 [19.1]	63.4 [18.6]	89.7 [26.3]	75.3 [22.1]	73.2 [21.5]	
	Power	8.5	8.2	8.2	8.5	8.2	8.2	8.5	8.2	8.1	
110 [43.3]	Total kBtu/h [kW]	103.3 [30.3]	96.1 [28.2]	95.1 [27.9]	96.3 [28.2]	89.6 [26.3]	88.7 [26.0]	89.3 [26.2]	83.1 [24.4]	82.2 [24.1]	
	Sens kBtu/h [kW]	64.6 [18.9]	54.2 [15.9]	52.7 [15.4]	76.7 [22.5]	64.3 [18.8]	62.6 [18.3]	88.7 [26.0]	74.4 [21.8]	72.4 [21.2]	
	Power	9.0	8.7	8.7	9.0	8.7	8.7	9.0	8.7	8.6	
115 [46.1]	Total kBtu/h [kW]	101.2 [29.7]	94.1 [27.6]	93.1 [27.3]	94.2 [27.6]	87.6 [25.7]	86.7 [25.4]	87.2 [25.6]	81.1 [23.8]	80.2 [23.5]	
	Sens kBtu/h [kW]	63.6 [18.6]	53.4 [15.7]	51.9 [15.2]	75.7 [22.2]	63.5 [18.6]	61.7 [18.1]	87.2 [25.6]	73.6 [21.6]	71.6 [21.0]	
	Power	9.6	9.3	9.2	9.6	9.2	9.2	9.6	9.2	9.2	
120 [48.9]	Total kBtu/h [kW]	99.0 [29.0]	92.1 [27.0]	91.1 [26.7]	92.0 [27.0]	85.6 [25.1]	84.7 [24.8]	85 [24.9]	79.1 [23.2]	78.3 [22.9]	
	Sens kBtu/h [kW]	62.7 [18.4]	52.6 [15.4]	51.1 [15.0]	74.7 [21.9]	62.7 [18.4]	60.9 [17.8]	85 [24.9]	72.8 [21.3]	70.8 [20.8]	
	Power	10.2	9.8	9.8	10.2	9.8	9.7	10.1	9.8	9.7	
125 [51.7]	Total kBtu/h [kW]	96.9 [28.4]	90.1 [26.4]	89.1 [26.1]	89.9 [26.3]	83.6 [24.5]	82.7 [24.2]	82.9 [24.3]	77.1 [22.6]	76.3 [22.4]	
	Sens kBtu/h [kW]	61.7 [18.1]	51.7 [15.2]	50.3 [14.7]	73.7 [21.6]	61.8 [18.1]	60.1 [17.6]	82.9 [24.3]	71.9 [21.1]	69.9 [20.5]	
	Power	10.8	10.4	10.4	10.8	10.4	10.3	10.8	10.4	10.3	

DR —Depression ratio
dbE —Entering air dry bulb
wbE —Entering air wet bulb

Total —Total capacity x 1000 Btu/h
Sens —Sensible capacity x 1000 Btu/h
Power —kW input

NOTES: ① When the entering air dry bulb is other than 80°F [27°C], adjust the sensible capacity from the table by adding [1.10 x CFM x (1 - DR) x (dbE - 80)].

[] Designates Metric Conversions

COOLING PERFORMANCE DATA – RHPDYC102

		ENTERING INDOOR AIR @ 80°F [26.7°C] dbE ①									
		71°F [21.7°C]			67°F [19.4°C]			63°F [17.2°C]			
wbE		4075 [1923]	3350 [1581]	2725 [1286]	4075 [1923]	3350 [1581]	2725 [1286]	4075 [1923]	3350 [1581]	2725 [1286]	
CFM [L/s]		4075 [1923]	3350 [1581]	2725 [1286]	4075 [1923]	3350 [1581]	2725 [1286]	4075 [1923]	3350 [1581]	2725 [1286]	
DR ①		.05	.09	.12	.05	.09	.12	.05	.09	.12	
OUTDOOR DRY BULB TEMPERATURE °F [°C]	75 [23.9]	Total kBtu/h [kW] Sens kBtu/h [kW] Power	133.0 [39.0] 78.2 [22.9] 7.1	128.0 [37.5] 71.0 [20.8] 7.0	123.7 [36.3] 64.8 [19.0] 6.9	125.5 [36.8] 92.9 [27.2] 7.1	120.7 [35.4] 84.4 [24.7] 6.9	116.7 [34.2] 77.0 [22.6] 6.8	118.4 [34.7] 104.9 [30.7] 7.0	113.9 [33.4] 95.3 [27.9] 6.9	110.1 [32.3] 87.0 [25.5] 6.8
	80 [26.7]	Total kBtu/h [kW] Sens kBtu/h [kW] Power	131.1 [38.4] 77.8 [22.8] 7.5	126.1 [37.0] 70.7 [20.7] 7.3	121.8 [35.7] 64.5 [18.9] 7.2	123.5 [36.2] 92.5 [27.1] 7.4	118.9 [34.8] 84.0 [24.6] 7.3	114.8 [33.6] 76.7 [22.5] 7.2	116.4 [34.1] 104.5 [30.6] 7.4	112.0 [32.8] 94.9 [27.8] 7.3	108.2 [31.7] 86.6 [25.4] 7.1
	85 [29.4]	Total kBtu/h [kW] Sens kBtu/h [kW] Power	128.7 [37.7] 77.1 [22.6] 7.9	123.9 [36.3] 70.0 [20.5] 7.7	119.7 [35.1] 63.9 [18.7] 7.6	121.2 [35.5] 91.8 [26.9] 7.8	116.6 [34.2] 83.3 [24.4] 7.7	112.7 [33.0] 76.1 [22.3] 7.6	114.1 [33.4] 103.7 [30.4] 7.8	109.8 [32.2] 94.2 [27.6] 7.7	106.1 [31.1] 86.0 [25.2] 7.5
	90 [32.2]	Total kBtu/h [kW] Sens kBtu/h [kW] Power	126.1 [37.0] 76.0 [22.3] 8.3	121.3 [35.6] 69.0 [20.2] 8.2	117.2 [34.3] 63.0 [18.5] 8.0	118.5 [34.7] 90.7 [26.6] 8.3	114.0 [33.4] 82.4 [24.2] 8.1	110.2 [32.3] 75.2 [22.0] 8.0	111.4 [32.6] 102.7 [30.1] 8.2	107.2 [31.4] 93.3 [27.3] 8.1	103.6 [30.4] 85.1 [24.9] 8.0
	95 [35]	Total kBtu/h [kW] Sens kBtu/h [kW] Power	123.0 [36.0] 74.6 [21.9] 8.8	118.4 [34.7] 67.7 [19.8] 8.6	114.3 [33.5] 61.9 [18.1] 8.5	115.5 [33.9] 89.3 [26.2] 8.7	111.1 [32.6] 81.1 [23.8] 8.6	107.3 [31.4] 74.0 [21.7] 8.4	108.4 [31.8] 101.3 [29.7] 8.7	104.3 [30.6] 92.0 [27.0] 8.5	100.7 [29.5] 84.0 [24.6] 8.4
	100 [37.8]	Total kBtu/h [kW] Sens kBtu/h [kW] Power	119.6 [35.1] 72.9 [21.4] 9.3	115.1 [33.7] 66.2 [19.4] 9.1	111.2 [32.6] 60.4 [17.7] 9.0	112.1 [32.9] 87.5 [25.6] 9.2	107.8 [31.6] 79.5 [23.3] 9.1	104.2 [30.5] 72.6 [21.3] 8.9	105.0 [30.8] 99.5 [29.2] 9.2	101.0 [29.6] 90.4 [26.5] 9.0	97.6 [28.6] 82.5 [24.2] 8.9
	105 [40.6]	Total kBtu/h [kW] Sens kBtu/h [kW] Power	115.9 [34.0] 70.8 [20.8] 9.8	111.5 [32.7] 64.3 [18.8] 9.6	107.7 [31.6] 58.7 [17.2] 9.5	108.3 [31.7] 85.5 [25.1] 9.8	104.2 [30.5] 77.6 [22.7] 9.6	100.7 [29.5] 70.9 [20.8] 9.4	101.2 [29.7] 97.5 [28.6] 9.7	97.4 [28.5] 88.5 [25.9] 9.5	94.1 [27.6] 80.8 [23.7] 9.4
	110 [43.3]	Total kBtu/h [kW] Sens kBtu/h [kW] Power	111.8 [32.8] 68.4 [20.0] 10.4	107.5 [31.5] 62.1 [18.2] 10.2	103.9 [30.5] 56.7 [16.6] 10.0	104.2 [30.5] 83.1 [24.4] 10.3	100.3 [29.4] 75.4 [22.1] 10.1	96.9 [28.4] 68.9 [20.2] 10.0	97.1 [28.5] 95.0 [27.8] 10.3	93.5 [27.4] 86.3 [25.3] 10.1	90.3 [26.5] 78.8 [23.1] 9.9
	115 [46.1]	Total kBtu/h [kW] Sens kBtu/h [kW] Power	107.3 [31.4] 65.6 [19.2] 10.9	103.3 [30.3] 59.6 [17.5] 10.7	99.8 [29.2] 54.4 [15.9] 10.6	99.8 [29.2] 80.3 [23.5] 10.9	96.0 [28.1] 72.9 [21.4] 10.7	92.8 [27.2] 66.6 [19.5] 10.5	92.7 [27.2] 92.3 [27.1] 10.9	89.2 [26.1] 83.8 [24.6] 10.7	86.2 [25.3] 76.5 [22.4] 10.5
	120 [48.9]	Total kBtu/h [kW] Sens kBtu/h [kW] Power	102.5 [30.0] 62.5 [18.3] 11.5	98.6 [28.9] 56.8 [16.6] 11.3	95.3 [27.9] 51.9 [15.2] 11.1	95.0 [27.8] 77.2 [22.6] 11.5	91.4 [26.8] 70.2 [20.6] 11.3	88.3 [25.9] 64.0 [18.8] 11.1	87.9 [25.8] 87.9 [25.8] 11.5	84.6 [24.8] 81.0 [23.7] 11.3	81.7 [23.9] 74.0 [21.7] 11.1
125 [51.7]	Total kBtu/h [kW] Sens kBtu/h [kW] Power	97.4 [28.5] 59.1 [17.3] 12.2	93.7 [27.5] 53.7 [15.7] 12.0	90.5 [26.5] 49.0 [14.4] 11.8	89.8 [26.3] 73.8 [21.6] 12.2	86.4 [25.3] 67.1 [19.7] 11.9	83.5 [24.5] 61.2 [17.9] 11.7	82.7 [24.2] 82.7 [24.2] 12.1	79.6 [23.3] 77.9 [22.8] 11.9	76.9 [22.5] 71.2 [20.9] 11.7	

DR —Depression ratio
dbE —Entering air dry bulb
wbE—Entering air wet bulb

Total —Total capacity x 1000 Btu/h
Sens —Sensible capacity x 1000 Btu/h
Power —kW input

NOTES: ① When the entering air dry bulb is other than 80°F [27°C], adjust the sensible capacity from the table by adding [1.10 x CFM x (1 – DR) x (dbE – 80)].

[] Designates Metric Conversions

COOLING PERFORMANCE DATA—RHPDYC120

		ENTERING INDOOR AIR @ 80°F [26.7°C] dbE ①									
wbE		71°F [21.7°C]			67°F [19.4°C]			63°F [17.2°C]			
CFM [L/s]		4800 [2265]	4750 [2242]	3200 [1510]	4800 [2265]	4750 [2242]	3200 [1510]	4800 [2265]	4750 [2242]	3200 [1510]	
DR ①		.05	.09	.12	.05	.09	.12	.05	.09	.12	
OUTDOOR DRY BULB TEMPERATURE °F [°C]	75 [23.9]	Total kBtu/h [kW] Sens kBtu/h [kW] Power	133.9 [39.2] 79.6 [23.3] 7.9	133.6 [39.2] 79.2 [23.2] 7.9	125.7 [36.8] 67.2 [19.7] 7.7	127.4 [37.3] 97.4 [28.5] 7.9	127.2 [37.3] 96.9 [28.4] 7.9	119.7 [35.1] 82.1 [24.1] 7.6	121 [35.5] 106.9 [31.3] 7.8	120.8 [35.4] 106.3 [31.2] 7.8	113.6 [33.3] 90.1 [26.4] 7.6
	80 [26.7]	Total kBtu/h [kW] Sens kBtu/h [kW] Power	131.2 [38.5] 79.1 [23.2] 8.3	131.0 [38.4] 78.7 [23.1] 8.3	123.2 [36.1] 66.8 [19.6] 8.1	124.7 [36.5] 96.9 [28.4] 8.3	124.5 [36.5] 96.4 [28.3] 8.3	117.1 [34.3] 81.7 [23.9] 8.0	118.3 [34.7] 106.4 [31.2] 8.2	118.1 [34.6] 105.8 [31.0] 8.2	111.1 [32.6] 89.7 [26.3] 8.0
	85 [29.4]	Total kBtu/h [kW] Sens kBtu/h [kW] Power	128.5 [37.7] 78.6 [23.0] 8.8	128.3 [37.6] 78.2 [22.9] 8.8	120.7 [35.4] 66.3 [19.4] 8.5	122.1 [35.8] 96.3 [28.2] 8.7	121.8 [35.7] 95.8 [28.1] 8.7	114.6 [33.6] 81.2 [23.8] 8.5	115.6 [33.9] 105.8 [31.0] 8.7	115.4 [33.8] 105.3 [30.9] 8.7	108.5 [31.8] 89.3 [26.2] 8.4
	90 [32.2]	Total kBtu/h [kW] Sens kBtu/h [kW] Power	125.8 [36.9] 78.0 [22.9] 9.2	125.6 [36.8] 77.6 [22.7] 9.2	118.1 [34.6] 65.8 [19.3] 9.0	119.4 [35.0] 95.7 [28.0] 9.2	119.1 [34.9] 95.2 [27.9] 9.2	112.1 [32.9] 80.7 [23.7] 8.9	112.9 [33.1] 105.2 [30.8] 9.1	112.7 [33.0] 104.7 [30.7] 9.1	106.0 [31.1] 88.8 [26.0] 8.9
	95 [35]	Total kBtu/h [kW] Sens kBtu/h [kW] Power	123.1 [36.1] 77.3 [22.7] 9.7	122.9 [36.0] 77.0 [22.6] 9.7	115.6 [33.9] 65.2 [19.1] 9.4	116.7 [34.2] 95.1 [27.9] 9.7	116.4 [34.1] 94.6 [27.7] 9.7	109.5 [32.1] 80.2 [23.5] 9.4	110.2 [32.3] 104.6 [30.7] 9.6	110.0 [32.2] 104.1 [30.5] 9.6	103.5 [30.3] 88.2 [25.8] 9.4
	100 [37.8]	Total kBtu/h [kW] Sens kBtu/h [kW] Power	120.4 [35.3] 76.6 [22.5] 10.3	120.2 [35.2] 76.3 [22.4] 10.3	113.1 [33.1] 64.6 [18.9] 10.0	114.0 [33.4] 94.4 [27.7] 10.2	113.7 [33.3] 93.9 [27.5] 10.2	107.0 [31.4] 79.6 [23.3] 9.9	107.5 [31.5] 103.9 [30.5] 10.2	107.3 [31.4] 103.4 [30.3] 10.2	100.9 [29.6] 87.6 [25.7] 9.9
	105 [40.6]	Total kBtu/h [kW] Sens kBtu/h [kW] Power	117.7 [34.5] 75.9 [22.2] 10.9	117.5 [34.4] 75.5 [22.1] 10.8	110.5 [32.4] 64.0 [18.8] 10.5	111.3 [32.6] 93.6 [27.4] 10.8	111.1 [32.6] 93.1 [27.3] 10.8	104.5 [30.6] 79.0 [23.2] 10.5	104.8 [30.7] 103.1 [30.2] 10.8	104.6 [30.7] 102.6 [30.1] 10.8	98.4 [28.8] 87.0 [25.5] 10.4
	110 [43.3]	Total kBtu/h [kW] Sens kBtu/h [kW] Power	115.0 [33.7] 75.1 [22.0] 11.5	114.8 [33.6] 74.7 [21.9] 11.5	108.0 [31.7] 63.3 [18.6] 11.1	108.6 [31.8] 92.8 [27.2] 11.4	108.4 [31.8] 92.3 [27.1] 11.4	101.9 [29.9] 78.3 [22.9] 11.1	102.1 [29.9] 102.1 [29.9] 11.4	101.9 [29.9] 101.8 [29.8] 11.4	95.9 [28.1] 86.3 [25.3] 11.0
	115 [46.1]	Total kBtu/h [kW] Sens kBtu/h [kW] Power	112.3 [32.9] 74.2 [21.7] 12.1	112.1 [32.9] 73.8 [21.6] 12.1	105.5 [30.9] 62.6 [18.3] 11.7	105.9 [31.0] 91.9 [26.9] 12.1	105.7 [31.0] 91.5 [26.8] 12.1	99.4 [29.1] 77.6 [22.7] 11.7	99.4 [29.1] 99.4 [29.1] 12.0	99.2 [29.1] 99.2 [29.1] 12.0	93.3 [27.3] 85.6 [25.1] 11.7
	120 [48.9]	Total kBtu/h [kW] Sens kBtu/h [kW] Power	109.6 [32.1] 73.3 [21.5] 12.8	109.4 [32.1] 72.9 [21.4] 12.8	102.9 [30.2] 61.8 [18.1] 12.4	103.2 [30.2] 91.0 [26.7] 12.7	103.0 [30.2] 90.6 [26.6] 12.7	96.9 [28.4] 76.8 [22.5] 12.4	96.7 [28.3] 96.7 [28.3] 12.7	96.5 [28.3] 96.5 [28.3] 12.7	90.8 [26.6] 84.8 [24.9] 12.3
	125 [51.7]	Total kBtu/h [kW] Sens kBtu/h [kW] Power	106.9 [31.3] 72.3 [21.2] 13.5	106.7 [31.3] 72.0 [21.1] 13.5	100.4 [29.4] 61.0 [17.9] 13.1	100.5 [29.5] 90.1 [26.4] 13.5	100.3 [29.4] 89.6 [26.3] 13.4	94.3 [27.6] 76.0 [22.3] 13.1	94.0 [27.5] 94.0 [27.5] 13.4	93.9 [27.5] 93.9 [27.5] 13.4	88.3 [25.9] 84.0 [24.6] 13.0

DR —Depression ratio
dbE —Entering air dry bulb
wbE —Entering air wet bulb

Total —Total capacity x 1000 Btu/h
Sens —Sensible capacity x 1000 Btu/h
Power —kW input

NOTES: ① When the entering air dry bulb is other than 80°F [27°C], adjust the sensible capacity from the table by adding $[1.10 \times \text{CFM} \times (1 - \text{DR}) \times (\text{dbE} - 80)]$.

[] Designates Metric Conversions

HEATING PERFORMANCE DATA—RHPDYC078

IDB		60°F [15.6°C]			70°F [21.1°C]			80°F [26.7°C]			
CFM [L/s]		3125 [1475]	2250 [1062]	2075 [979]	3125 [1475]	2250 [1062]	2075 [979]	3125 [1475]	2250 [1062]	2075 [979]	
OUTDOOR DRY BULB TEMPERATURE °F [°C]	0 [-17.8]	Total kBtu/h [kW] Power	25.1 [7.4] 4.1	24.4 [7.2] 4.3	24.3 [7.1] 4.4	24.8 [7.3] 4.4	24.1 [7.1] 4.6	24.0 [7.0] 4.7	24.5 [7.2] 4.7	23.8 [7.0] 4.9	23.7 [6.9] 5.0
	5 [-15.0]	Total kBtu/h [kW] Power	30.7 [9.0] 3.5	29.9 [8.8] 3.7	29.7 [8.7] 3.7	30.4 [8.9] 3.8	29.6 [8.7] 4.0	29.4 [8.6] 4.0	30.1 [8.8] 4.1	29.3 [8.6] 4.3	29.1 [8.5] 4.3
	10 [-12.2]	Total kBtu/h [kW] Power	36.3 [10.6] 3	35.3 [10.3] 3.2	35.1 [10.3] 3.2	36.0 [10.6] 3.3	35.0 [10.3] 3.5	34.8 [10.2] 3.5	35.7 [10.5] 3.6	34.7 [10.2] 3.8	34.6 [10.1] 3.8
	15 [-9.4]	Total kBtu/h [kW] Power	41.9 [12.3] 2.6	40.8 [12.0] 2.8	40.5 [11.9] 2.8	41.6 [12.2] 2.9	40.5 [11.9] 3.1	40.3 [11.8] 3.1	41.3 [12.1] 3.2	40.2 [11.8] 3.4	40.0 [11.7] 3.4
	20 [-6.7]	Total kBtu/h [kW] Power	47.5 [13.9] 2.3	46.2 [13.5] 2.5	46.0 [13.5] 2.5	47.2 [13.8] 2.6	45.9 [13.5] 2.8	45.7 [13.4] 2.8	46.9 [13.7] 2.9	45.7 [13.4] 3.1	45.4 [13.3] 3.1
	25 [-3.9]	Total kBtu/h [kW] Power	53.1 [15.6] 2.2	51.7 [15.2] 2.3	51.4 [15.1] 2.3	52.8 [15.5] 2.5	51.4 [15.1] 2.6	51.1 [15.0] 2.6	52.5 [15.4] 2.8	51.1 [15.0] 2.9	50.8 [14.9] 3.0
	30 [-1.1]	Total kBtu/h [kW] Power	58.7 [17.2] 2.2	57.1 [16.7] 2.3	56.8 [16.6] 2.3	58.4 [17.1] 2.5	56.8 [16.6] 2.6	56.5 [16.6] 2.6	58.1 [17.0] 2.8	56.6 [16.6] 2.9	56.2 [16.5] 2.9
	35 [1.7]	Total kBtu/h [kW] Power	64.3 [18.8] 2.2	62.6 [18.3] 2.4	62.2 [18.2] 2.4	64.0 [18.8] 2.5	62.3 [18.3] 2.7	62.0 [18.2] 2.7	63.7 [18.7] 2.8	62.0 [18.2] 3.0	61.7 [18.1] 3.0
	40 [4.4]	Total kBtu/h [kW] Power	69.9 [20.5] 2.4	68.0 [19.9] 2.6	67.7 [19.8] 2.6	69.6 [20.4] 2.7	67.8 [19.9] 2.9	67.4 [19.8] 2.9	69.3 [20.3] 3.0	67.5 [19.8] 3.2	67.1 [19.7] 3.2
	45 [7.2]	Total kBtu/h [kW] Power	75.5 [22.1] 2.8	73.5 [21.5] 2.9	73.1 [21.4] 2.9	75.2 [22.0] 3.1	73.2 [21.5] 3.2	72.8 [21.3] 3.2	74.9 [22.0] 3.4	72.9 [21.4] 3.5	72.5 [21.2] 3.6
50 [10.0]	Total kBtu/h [kW] Power	81.1 [23.8] 3.2	78.9 [23.1] 3.4	78.5 [23] 3.4	80.8 [23.7] 3.5	78.7 [23.1] 3.7	78.2 [22.9] 3.7	80.6 [23.6] 3.8	78.4 [23.0] 4.0	77.9 [22.8] 4.0	

IDB—Indoor air dry bulb

HEATING PERFORMANCE DATA—RHPDYC090

IDB		60°F [15.6°C]			70°F [21.1°C]			80°F [26.7°C]			
CFM [L/s]		3600 [1699]	2550 [1203]	2400 [1133]	3600 [1699]	2550 [1203]	2400 [1133]	3600 [1699]	2550 [1203]	2400 [1133]	
OUTDOOR DRY BULB TEMPERATURE °F [°C]	0 [-17.8]	Total kBtu/h [kW] Power	38.4 [11.3] 2.6	37.3 [10.9] 2.7	37.2 [10.9] 2.8	36.5 [10.7] 2.9	35.5 [10.4] 3.0	35.3 [10.3] 3.0	34.6 [10.1] 3.1	33.6 [9.8] 3.3	33.5 [9.8] 3.3
	5 [-15.0]	Total kBtu/h [kW] Power	44.2 [13.0] 2.6	42.9 [12.6] 2.7	42.7 [12.5] 2.7	42.3 [12.4] 2.8	41.1 [12.0] 3.0	40.9 [12.0] 3.0	40.4 [11.8] 3.1	39.2 [11.5] 3.3	39.1 [11.5] 3.3
	10 [-12.2]	Total kBtu/h [kW] Power	49.9 [14.6] 2.6	48.5 [14.2] 2.7	48.3 [14.2] 2.7	48.1 [14.1] 2.8	46.7 [13.7] 3.0	46.5 [13.6] 3.0	46.2 [13.5] 3.1	44.8 [13.1] 3.2	44.6 [13.1] 3.3
	15 [-9.4]	Total kBtu/h [kW] Power	55.7 [16.3] 2.6	54.1 [15.9] 2.7	53.9 [15.8] 2.7	53.8 [15.8] 2.8	52.3 [15.3] 3.0	52.1 [15.3] 3.0	51.9 [15.2] 3.1	50.4 [14.8] 3.2	50.2 [14.7] 3.3
	20 [-6.7]	Total kBtu/h [kW] Power	61.5 [18.0] 2.6	59.7 [17.5] 2.7	59.5 [17.4] 2.7	59.6 [17.5] 2.8	57.9 [17.0] 3.0	57.6 [16.9] 3.0	57.7 [16.9] 3.1	5.06 [16.4] 3.2	55.8 [16.4] 3.3
	25 [-3.9]	Total kBtu/h [kW] Power	67.2 [19.7] 2.6	65.3 [19.1] 2.7	65.0 [19.1] 2.7	65.3 [19.1] 2.8	63.5 [18.6] 3.0	63.2 [18.5] 3.0	63.4 [18.6] 3.1	61.6 [18.1] 3.3	61.4 [18.0] 3.3
	30 [-1.1]	Total kBtu/h [kW] Power	73.0 [21.4] 2.6	70.9 [20.8] 2.7	70.6 [20.7] 2.8	71.1 [20.8] 2.9	69.1 [20.3] 3.0	68.8 [20.2] 3.0	69.2 [20.3] 3.1	67.2 [19.7] 3.3	66.9 [19.6] 3.3
	35 [1.7]	Total kBtu/h [kW] Power	78.8 [23.1] 2.6	76.5 [22.4] 2.8	76.2 [22.3] 2.8	76.9 [22.5] 2.9	74.7 [21.9] 3.0	74.4 [21.8] 3.1	75.0 [22.0] 3.1	72.8 [21.3] 3.3	72.5 [21.2] 3.3
	40 [4.4]	Total kBtu/h [kW] Power	84.5 [24.8] 2.7	82.1 [24.1] 2.8	81.8 [24.0] 2.8	82.6 [24.2] 2.9	80.3 [23.5] 3.1	79.9 [23.4] 3.1	80.7 [23.7] 3.2	78.4 [23.0] 3.4	78.1 [22.9] 3.4
	45 [7.2]	Total kBtu/h [kW] Power	90.3 [26.5] 2.7	87.7 [25.7] 2.9	87.3 [25.6] 2.9	88.4 [25.9] 3	85.9 [25.2] 3.1	85.5 [25.1] 3.2	86.5 [25.4] 3.2	84.0 [24.6] 3.4	83.7 [24.5] 3.4
50 [10.0]	Total kBtu/h [kW] Power	96.1 [28.2] 2.8	93.3 [27.3] 2.9	92.9 [27.2] 3.0	94.2 [27.6] 3.0	91.5 [26.8] 3.2	91.1 [26.7] 3.2	92.3 [27.1] 3.3	89.6 [26.3] 3.5	89.2 [26.1] 3.5	

IDB—Indoor air dry bulb

[] Designates Metric Conversions

HEATING PERFORMANCE DATA—RHPDYC102

IDB		60°F [15.6°C]			70°F [21.1°C]			80°F [26.7°C]			
CFM [L/s]		4075 [1923]	3350 [1581]	2725 [1286]	4075 [1923]	3350 [1581]	2725 [1286]	4075 [1923]	3350 [1581]	2725 [1286]	
OUTDOOR DRY BULB TEMPERATURE °F [°C]	0 [-17.8]	Total kBtu/h [kW] Power	41.3 [12.1] 3.9	40.7 [11.9] 4.1	40.1 [11.8] 4.1	39.4 [11.5] 4.2	38.8 [11.4] 4.3	38.3 [11.2] 4.4	37.5 [11.0] 4.7	36.9 [10.8] 4.8	36.4 [10.7] 4.9
	5 [-15.0]	Total kBtu/h [kW] Power	48.2 [14.1] 4.0	47.4 [13.9] 4.1	46.8 [13.7] 4.2	46.3 [13.6] 4.3	45.6 [13.4] 4.4	45.0 [13.2] 4.5	44.4 [13.0] 4.7	43.7 [12.8] 4.9	43.1 [12.6] 5.0
	10 [-12.2]	Total kBtu/h [kW] Power	55.1 [16.1] 4.0	54.2 [15.9] 4.2	53.5 [15.7] 4.2	53.2 [15.6] 4.3	52.3 [15.3] 4.4	51.6 [15.1] 4.5	51.3 [15.0] 4.8	50.5 [14.8] 4.9	49.8 [14.6] 5.0
	15 [-9.4]	Total kBtu/h [kW] Power	61.9 [18.1] 4.1	61.0 [17.9] 4.2	60.2 [17.6] 4.3	60.0 [17.6] 4.4	59.1 [17.3] 4.5	58.3 [17.1] 4.6	58.1 [17.0] 4.8	57.3 [16.8] 5.0	56.5 [16.6] 5.1
	20 [-6.7]	Total kBtu/h [kW] Power	68.8 [20.2] 4.1	67.8 [19.9] 4.3	66.9 [19.6] 4.4	66.9 [19.6] 4.4	65.9 [19.3] 4.5	65.0 [19.1] 4.6	65.0 [19.1] 4.9	64.0 [18.8] 5.0	63.2 [18.5] 5.1
	25 [-3.9]	Total kBtu/h [kW] Power	75.7 [22.2] 4.2	74.5 [21.8] 4.3	73.5 [21.5] 4.4	73.8 [21.6] 4.5	72.7 [21.3] 4.6	71.7 [21.0] 4.7	71.9 [21.1] 4.9	70.8 [20.8] 5.1	69.9 [20.5] 5.2
	30 [-1.1]	Total kBtu/h [kW] Power	82.6 [24.2] 4.2	81.3 [23.8] 4.4	80.2 [23.5] 4.5	80.7 [23.7] 4.5	79.5 [23.3] 4.6	78.4 [23.0] 4.7	78.8 [23.1] 5.0	77.6 [22.7] 5.1	76.6 [22.5] 5.2
	35 [1.7]	Total kBtu/h [kW] Power	89.5 [26.2] 4.3	88.1 [25.8] 4.4	86.9 [25.5] 4.5	87.6 [25.7] 4.5	86.2 [25.3] 4.7	85.1 [24.9] 4.8	85.7 [25.1] 5.0	84.4 [24.7] 5.2	83.2 [24.4] 5.3
	40 [4.4]	Total kBtu/h [kW] Power	96.3 [28.2] 4.3	94.9 [27.8] 4.5	93.6 [27.4] 4.6	94.4 [27.7] 4.6	93.0 [27.3] 4.7	91.8 [26.9] 4.8	92.5 [27.1] 5.1	91.1 [26.7] 5.2	89.9 [26.3] 5.3
	45 [7.2]	Total kBtu/h [kW] Power	103.2 [30.2] 4.4	101.6 [29.8] 4.5	100.3 [29.4] 4.6	101.3 [29.7] 4.6	99.8 [29.2] 4.8	98.5 [28.9] 4.9	99.4 [29.1] 5.1	97.9 [28.7] 5.3	96.6 [28.3] 5.4
50 [10.0]	Total kBtu/h [kW] Power	110.1 [32.3] 4.4	108.4 [31.8] 4.6	107.0 [31.4] 4.7	108.2 [31.7] 4.7	106.6 [31.2] 4.8	105.1 [30.8] 4.9	106.3 [31.2] 5.2	104.7 [30.7] 5.3	103.3 [30.3] 5.4	

IDB—Indoor air dry bulb

HEATING PERFORMANCE DATA—RHPDYC120

IDB		60°F [15.6°C]			70°F [21.1°C]			80°F [26.7°C]			
CFM [L/s]		4800 [2265]	4750 [2242]	3200 [1510]	4800 [2265]	4750 [2242]	3200 [1510]	4800 [2265]	4750 [2242]	3200 [1510]	
OUTDOOR DRY BULB TEMPERATURE °F [°C]	0 [-17.8]	Total kBtu/h [kW] Power	42.5 [12.5] 4.6	42.4 [12.4] 4.6	41.4 [12.1] 4.8	40.4 [11.8] 5.4	40.3 [11.8] 5.4	39.4 [11.5] 5.6	38.3 [11.2] 5.4	38.2 [11.2] 5.4	37.3 [10.9] 5.6
	5 [-15.0]	Total kBtu/h [kW] Power	49.7 [14.6] 4.7	49.7 [14.6] 4.7	48.5 [14.2] 4.9	47.6 [14.0] 5.5	47.6 [14.0] 5.5	46.5 [13.6] 5.7	45.5 [13.3] 5.4	45.5 [13.3] 5.4	44.4 [13.0] 5.6
	10 [-12.2]	Total kBtu/h [kW] Power	57.0 [16.7] 4.7	56.9 [16.7] 4.7	55.6 [16.3] 4.9	54.9 [16.1] 5.5	54.8 [16.1] 5.5	53.6 [15.7] 5.7	52.8 [15.5] 5.4	52.7 [15.4] 5.5	51.5 [15.1] 5.7
	15 [-9.4]	Total kBtu/h [kW] Power	64.2 [18.8] 4.8	64.2 [18.8] 4.8	62.7 [18.4] 5.0	62.1 [18.2] 5.5	62.1 [18.2] 5.6	60.6 [17.8] 5.8	60.0 [17.6] 5.5	60.0 [17.6] 5.5	58.6 [17.2] 5.7
	20 [-6.7]	Total kBtu/h [kW] Power	71.5 [21.0] 4.8	71.4 [20.9] 4.8	69.8 [20.5] 5.0	69.4 [20.3] 5.6	69.3 [20.3] 5.6	67.7 [19.8] 5.8	67.3 [19.7] 5.5	67.3 [19.7] 5.5	65.7 [19.3] 5.8
	25 [-3.9]	Total kBtu/h [kW] Power	78.8 [23.1] 4.8	78.7 [23.1] 4.9	76.9 [22.5] 5.0	76.7 [22.5] 5.6	76.6 [22.5] 5.6	74.8 [21.9] 5.9	74.6 [21.9] 5.6	74.5 [21.8] 5.6	72.8 [21.3] 5.8
	30 [-1.1]	Total kBtu/h [kW] Power	86.0 [25.2] 4.9	86.0 [25.2] 4.9	83.9 [24.6] 5.1	83.9 [24.6] 5.7	83.9 [24.6] 5.7	81.9 [24.0] 5.9	81.8 [24.0] 5.6	81.8 [24.0] 5.6	79.9 [23.4] 5.9
	35 [1.7]	Total kBtu/h [kW] Power	93.3 [27.3] 4.9	93.2 [27.3] 4.9	91.0 [26.7] 5.1	91.2 [26.7] 5.7	91.1 [26.7] 5.7	89.0 [26.1] 6.0	89.1 [26.1] 5.7	89.0 [26.1] 5.7	86.9 [25.5] 5.9
	40 [4.4]	Total kBtu/h [kW] Power	100.5 [29.5] 5.0	100.5 [29.5] 5.0	98.1 [28.8] 5.2	98.4 [28.8] 5.8	98.4 [28.8] 5.8	96.1 [28.2] 6.0	96.3 [28.2] 5.7	96.3 [28.2] 5.7	94.0 [27.5] 5.9
	45 [7.2]	Total kBtu/h [kW] Power	107.8 [31.6] 5.0	107.7 [31.6] 5.0	105.2 [30.8] 5.2	105.7 [31.0] 5.8	105.6 [30.9] 5.8	103.2 [30.2] 6.1	103.6 [30.4] 5.7	103.5 [30.3] 5.8	101.1 [29.6] 6.0
50 [10.0]	Total kBtu/h [kW] Power	115.1 [33.7] 5.1	115.0 [33.7] 5.1	112.3 [32.9] 5.3	113.0 [33.1] 5.9	112.9 [33.1] 5.9	110.2 [32.3] 6.1	110.9 [32.5] 5.8	110.8 [32.5] 5.8	108.2 [31.7] 6.0	

IDB—Indoor air dry bulb

[] Designates Metric Conversions

AIRFLOW PERFORMANCE — 6.5 TON — 60 Hz — 208/230V — DOWNFLOW

Air Flow	Model RHPDYC078 Voltage 208/230V — 3 phase 60 Hz																																
	External Static Pressure—Inches of Water [kPa]																																
	0.1 [.02]			0.2 [.05]			0.3 [.07]			0.4 [.10]			0.5 [.12]			0.6 [.15]			0.7 [.17]			0.8 [.20]			0.9 [.22]			1.0 [.25]					
	RPM	W	%	RPM	W	%	RPM	W	%	RPM	W	%	RPM	W	%	RPM	W	%	RPM	W	%	RPM	W	%	RPM	W	%	RPM	W	%	RPM	W	%
2100 [991]	679	175	29.1	732	222	31.6	780	266	33.7	821	307	35.4	858	348	37.0	903	403	39.0	936	445	40.4	973	497	42.0	999	535	43.1	1033	586	44.5			
2200 [1038]	704	194	30.2	755	242	32.6	803	288	34.7	841	328	36.3	880	375	38.0	925	431	40.0	953	468	41.1	995	531	43.0	1020	571	44.0	1048	614	45.2			
2300 [1085]	733	216	31.6	779	262	33.7	824	310	35.7	861	351	37.2	903	402	39.0	945	459	40.9	973	497	42.0	1014	560	43.8	1043	610	45.0	1068	652	46.1			
2400 [1133]	762	239	32.8	804	284	34.8	847	333	36.6	883	376	38.2	925	430	40.0	965	486	41.7	995	531	43.0	1030	587	44.5	1066	647	46.0	1089	691	47.0			
2500 [1180]	787	259	33.9	827	307	35.8	869	357	37.6	905	402	39.1	948	460	41.0	982	511	42.4	1019	567	44.0	1046	614	45.1	1086	683	46.9	1109	729	48.0			
2600 [1227]	812	282	35.0	853	332	36.9	892	383	38.5	927	431	40.1	971	491	42.0	999	537	43.2	1041	604	44.9	1067	650	46.1	1103	715	47.7	1130	770	49.0			
2700 [1274]	833	303	36.0	877	358	37.9	914	409	39.5	951	462	41.1	993	525	42.9	1021	569	44.1	1062	639	45.8	1089	689	47.0	1122	751	48.6	1149	808	49.9			
2800 [1321]	858	328	37.0	901	386	38.9	939	439	40.5	973	493	42.1	1016	559	43.9	1043	605	45.0	1080	670	46.6	1110	728	48.0	1142	792	49.5	1169	851	50.9			
2900 [1368]	883	354	38.1	925	414	40.0	963	469	41.5	995	525	43.0	1038	594	44.8	1067	644	46.0	1101	708	47.6	1132	769	49.0	1161	830	50.5	1189	894	51.8			
3000 [1416]	909	383	39.2	948	442	41.0	986	501	42.5	1020	559	44.0	1058	628	45.7	1089	683	47.0	1122	747	48.5	1152	809	50.0	1179	869	51.3	1208	938	52.8			
3100 [1463]	938	419	40.5	972	473	42.0	1011	536	43.6	1044	595	45.0	1078	661	46.5	1110	722	48.0	1143	787	49.5	1172	849	51.0	1198	910	52.2	1228	982	53.7			

Air Flow	Model RHPDYC078 Voltage 208/230V — 3 phase 60 Hz																																			
	External Static Pressure—Inches of Water [kPa]																																			
	1.1 [.27]			1.2 [.30]			1.3 [.32]			1.4 [.35]			1.5 [.37]			1.6 [.40]			1.7 [.42]			1.8 [.45]			1.9 [.47]			2.0 [.50]								
	RPM	W	%	RPM	W	%	RPM	W	%	RPM	W	%	RPM	W	%	RPM	W	%	RPM	W	%	RPM	W	%	RPM	W	%	RPM	W	%	RPM	W	%	RPM	W	%
2100 [991]	1065	639	45.9	1088	680	47.0	1112	718	48.0	1142	774	49.5	1172	831	50.9	1195	876	52.0	1220	923	53.1	1247	978	54.3	1277	1045	55.6	1304	1109	56.7						
2200 [1038]	1081	672	46.7	1106	718	47.9	1132	762	49.0	1157	807	50.2	1189	873	51.8	1214	924	53.0	1239	973	54.0	1264	1025	55.0	1287	1075	56.0	1312	1133	57.0						
2300 [1085]	1097	703	47.4	1124	758	48.8	1150	805	50.0	1174	849	51.1	1202	905	52.4	1233	972	53.8	1260	1029	55.0	1284	1083	56.0	1309	1140	57.0	1337	1209	58.0						
2400 [1133]	1114	739	48.2	1142	797	49.6	1169	850	50.9	1193	897	52.1	1218	946	53.2	1247	1008	54.5	1275	1073	55.7	1303	1138	56.8	1329	1200	57.8	1342	1226	58.2						
2500 [1180]	1135	781	49.2	1161	840	50.6	1189	899	51.9	1212	945	53.0	1237	996	54.1	1263	1053	55.2	1286	1104	56.2	1310	1158	57.1	1335	1219	58.0	1363	1293	59.0						
2600 [1227]	1154	822	50.2	1180	882	51.5	1208	944	52.8	1233	998	54.0	1257	1052	55.0	1281	1105	56.0	1306	1162	57.0	1332	1227	58.0	1362	1304	59.0	1388	1375	59.8						
2700 [1274]	1171	859	51.1	1197	920	52.3	1227	990	53.7	1255	1054	54.9	1278	1107	55.9	1302	1168	57.0	1330	1236	58.0	1356	1304	58.9	1369	1328	59.2	1393	1392	60.0						
2800 [1321]	1191	902	52.0	1214	956	53.1	1243	1029	54.4	1272	1100	55.7	1298	1166	56.8	1325	1234	57.9	1348	1293	58.6	1361	1320	59.1	1391	1401	60.0	1419	1482	61.3						
2900 [1368]	1212	949	53.0	1234	1005	54.0	1259	1067	55.1	1287	1137	56.3	1313	1210	57.4	1337	1271	58.3	1359	1324	59.0	1389	1411	60.0	1417	1490	61.3	1431	1517	62.3						
3000 [1416]	1233	999	54.0	1256	1058	55.0	1279	1115	56.0	1303	1180	57.0	1328	1251	58.0	1356	1326	59.0	1388	1418	60.0	1413	1490	61.1	1426	1514	62.1	1452	1590	63.5						
3100 [1463]	1254	1051	54.9	1277	1112	55.9	1302	1178	57.0	1328	1248	58.0	1356	1325	59.0	1385	1411	59.9	1406	1472	60.7	1421	1512	61.8	1448	1590	63.3	1471	1662	64.7						

NOTES: 1. Factory airflow setting of VDC (%) at AHRI minimum External Static Pressure. Adjust VDC (%) value to achieve desire airflow.
 2. Do not set outside range of VDC (%) values from the values shown in Table
 3. Drive data is for Sideflow/Downflow with dry coil. Add component resistance (below) to determine total External Static Pressure

Airflow	AIRFLOW CORRECTION FACTORS*			COMPONENT AIRFLOW RESISTANCE					
				Wet Coil	Horizontal Economizer RA Damper Open	Concentric Diffuser RXRN-AEF2000 & Concentric Adapter RXMC-DD01 (Flush)	Concentric Diffuser RXRN-AED2000 & Concentric Adapter RXMC-DD01 (Drop)	Pressure Drop MERV 8	Pressure Drop MERV 13
CFM [L/s]	Total kBtu/h	Sensible kBtu/h	Power kW	Resistance — Inches of Water [kPa]					
2400 [1133]	0.97	0.92	0.99	0.06 [.01]	0.21 [0.05]	0.66 [.16]	0.53 [.13]	0.093 [.02]	0.047 [.01]
2500 [1180]	0.97	0.93	0.99	0.06 [.01]	0.25 [0.06]	0.71 [.18]	0.57 [.14]	0.098 [.02]	0.055 [.01]
2600 [1227]	0.98	0.95	0.99	0.06 [.02]	0.28 [0.07]	0.75 [.19]	0.60 [.15]	0.103 [.02]	0.062 [.01]
2700 [1274]	0.99	0.96	0.99	0.07 [.02]	0.32 [0.08]	0.80 [.20]	0.65 [.16]	0.108 [.03]	0.070 [.02]
2800 [1321]	0.99	0.98	1.00	0.07 [.02]	0.36 [0.09]	0.85 [.21]	0.69 [.17]	0.113 [.03]	0.078 [.02]
2900 [1368]	1.00	1.00	1.00	0.08 [.02]	0.39 [0.10]	0.91 [.23]	0.74 [.18]	0.117 [.03]	0.085 [.02]
3000 [1416]	1.01	1.01	1.00	0.08 [.02]	0.43 [0.11]	0.96 [.24]	0.79 [.20]	0.122 [.03]	0.093 [.02]
3100 [1463]	1.01	1.03	1.00	0.09 [.02]	0.47 [0.12]	1.02 [.25]	0.86 [.21]	0.127 [.03]	0.100 [.02]

*Multiply correction factor times gross performance data resulting sensible capacity cannot exceed total capacity.

[] Designates Metric Conversions

AIRFLOW PERFORMANCE — 6.5 TON — 60 Hz — 208/230V — SIDEFLOW

Air Flow	Model RHPDYC078 Voltage 208/230V — 3 phase 60 Hz																																
	External Static Pressure—Inches of Water [kPa]																																
	0.1 [.02]			0.2 [.05]			0.3 [.07]			0.4 [.10]			0.5 [.12]			0.6 [.15]			0.7 [.17]			0.8 [.20]			0.9 [.22]			1.0 [.25]					
	RPM	W	%	RPM	W	%	RPM	W	%	RPM	W	%	RPM	W	%	RPM	W	%	RPM	W	%	RPM	W	%	RPM	W	%	RPM	W	%	RPM	W	%
2100 [991]	654	156	28.0	704	195	30.3	757	242	32.5	805	289	34.6	841	329	36.3	883	378	38.0	923	428	39.8	952	466	41.0	994	526	43.0	1023	568	44.0			
2200 [1038]	677	171	29.0	727	211	31.3	778	260	33.4	820	304	35.3	859	349	37.0	904	404	39.0	935	444	40.3	974	497	42.0	1005	543	43.4	1044	605	44.9			
2300 [1085]	702	187	30.1	752	230	32.3	799	278	34.4	837	322	36.1	882	374	38.0	925	431	39.9	953	469	41.1	996	530	42.9	1020	566	44.0	1051	618	45.2			
2400 [1133]	724	203	31.1	775	249	33.4	821	298	35.3	859	345	37.0	904	401	39.0	941	451	40.6	974	499	42.0	1007	549	43.4	1044	606	45.0	1069	650	46.0			
2500 [1180]	749	221	32.1	797	267	34.3	842	318	36.3	882	370	38.0	925	426	39.8	955	470	41.2	997	532	43.0	1024	575	44.1	1063	641	45.8	1091	689	47.0			
2600 [1227]	775	242	33.3	822	289	35.4	865	341	37.2	905	395	39.0	942	448	40.6	975	497	42.0	1017	563	43.8	1045	611	45.0	1077	666	46.4	1110	726	47.9			
2700 [1274]	803	266	34.6	847	313	36.4	887	365	38.1	928	421	40.0	958	469	41.3	998	530	43.0	1030	583	44.4	1068	648	46.0	1093	694	47.1	1128	761	48.7			
2800 [1321]	828	288	35.7	871	337	37.5	910	390	39.1	949	448	40.9	977	494	42.1	1021	564	44.0	1047	609	45.1	1087	680	46.8	1112	729	48.0	1143	791	49.5			
2900 [1368]	854	313	36.8	894	362	38.5	932	415	40.1	972	476	41.9	1000	524	43.0	1040	593	44.8	1068	644	46.0	1103	708	47.5	1133	769	49.0	1161	827	50.4			
3000 [1416]	879	338	37.9	921	392	39.6	956	443	41.1	996	507	42.8	1023	556	44.0	1056	618	45.5	1091	683	47.0	1120	739	48.3	1152	806	50.0	1179	864	51.2			
3100 [1463]	903	363	38.9	946	421	40.7	979	472	42.1	1017	536	43.7	1046	590	45.0	1076	649	46.3	1111	718	47.9	1138	773	49.2	1173	845	50.9	1197	900	52.1			

Air Flow	Model RHPDYC078 Voltage 208/230V — 3 phase 60 Hz																																
	External Static Pressure—Inches of Water [kPa]																																
	1.1 [.27]			1.2 [.30]			1.3 [.32]			1.4 [.35]			1.5 [.37]			1.6 [.40]			1.7 [.42]			1.8 [.45]			1.9 [.47]			2.0 [.50]					
	RPM	W	%	RPM	W	%	RPM	W	%	RPM	W	%	RPM	W	%	RPM	W	%	RPM	W	%	RPM	W	%	RPM	W	%	RPM	W	%	RPM	W	%
2100 [991]	1047	609	45.1	1082	666	46.5	1111	716	47.8	1140	765	49.1	1174	831	50.8	1198	881	52.0	1222	931	53.1	1247	983	54.1	1273	1038	55.2	1295	1085	56.1			
2200 [1038]	1069	647	46.0	1095	692	47.1	1131	758	48.8	1157	804	50.0	1183	853	51.3	1215	923	52.8	1241	977	53.9	1265	1029	55.0	1291	1089	56.0	1316	1152	57.0			
2300 [1085]	1090	685	46.9	1113	727	48.0	1143	783	49.4	1176	846	51.0	1200	896	52.1	1226	951	53.3	1257	1018	54.6	1285	1086	55.9	1308	1144	56.8	1334	1203	57.7			
2400 [1133]	1104	713	47.6	1133	769	49.0	1158	815	50.1	1194	888	51.9	1218	939	53.0	1243	993	54.1	1267	1046	55.1	1291	1103	56.1	1313	1161	57.0	1342	1225	58.0			
2500 [1180]	1116	735	48.2	1151	804	49.9	1176	854	51.0	1205	915	52.4	1238	988	53.9	1262	1044	55.0	1286	1103	56.0	1311	1165	57.0	1337	1234	58.0	1369	1313	59.0			
2600 [1227]	1134	772	49.0	1168	838	50.7	1196	898	52.0	1220	953	53.1	1249	1015	54.4	1279	1090	55.7	1304	1153	56.7	1331	1223	57.8	1345	1258	58.3	1370	1315	59.0			
2700 [1274]	1154	812	50.0	1181	868	51.3	1216	943	52.9	1240	997	54.0	1264	1056	55.0	1289	1115	56.1	1314	1180	57.2	1337	1240	58.0	1367	1319	59.0	1399	1412	60.0			
2800 [1321]	1173	852	51.0	1197	904	52.1	1229	973	53.5	1261	1049	54.9	1284	1109	56.0	1309	1173	57.0	1336	1241	58.0	1365	1320	59.0	1389	1390	59.7	1402	1423	60.1			
2900 [1368]	1193	896	51.9	1217	949	53.0	1244	1008	54.1	1275	1086	55.6	1304	1158	56.8	1328	1225	57.7	1355	1295	58.6	1367	1325	59.0	1398	1416	60.0	1425	1498	61.4			
3000 [1416]	1211	935	52.7	1239	998	54.0	1263	1056	55.0	1286	1114	56.1	1314	1183	57.2	1337	1250	58.0	1365	1324	59.0	1397	1423	60.0	1424	1494	61.2	1440	1536	62.5			
3100 [1463]	1226	970	53.4	1258	1046	54.8	1284	1109	56.0	1310	1175	57.0	1337	1245	58.0	1363	1323	59.0	1392	1407	59.9	1408	1453	60.5	1430	1507	61.8	1458	1596	63.6			

- NOTES: 1. Factory airflow setting of VDC (%) at AHRI minimum External Static Pressure. Adjust VDC (%) value to achieve desire airflow.
 2. Do not set outside range of VDC (%) values from the values shown in Table
 3. Drive data is for Sideflow/Downflow with dry coil. Add component resistance (below) to determine total External Static Pressure

Airflow	AIRFLOW CORRECTION FACTORS*			COMPONENT AIRFLOW RESISTANCE					
				Wet Coil	Horizontal Economizer RA Damper Open	Concentric Diffuser RXRN-AEF2000 & Concentric Adapter RXMC-DD01 (Flush)	Concentric Diffuser RXRN-AED2000 & Concentric Adapter RXMC-DD01 (Drop)	Pressure Drop MERV 8	Pressure Drop MERV 13
CFM [L/s]	Total kBtu/h	Sensible kBtu/h	Power kW	Resistance — Inches of Water [kPa]					
2400 [1133]	0.97	0.92	0.99	0.06 [.01]	0.21 [0.05]	0.66 [.16]	0.53 [.13]	0.093 [.02]	0.047 [.01]
2500 [1180]	0.97	0.93	0.99	0.06 [.01]	0.25 [0.06]	0.71 [.18]	0.57 [.14]	0.098 [.02]	0.055 [.01]
2600 [1227]	0.98	0.95	0.99	0.06 [.02]	0.28 [0.07]	0.75 [.19]	0.60 [.15]	0.103 [.02]	0.062 [.01]
2700 [1274]	0.99	0.96	0.99	0.07 [.02]	0.32 [0.08]	0.80 [.20]	0.65 [.16]	0.108 [.03]	0.070 [.02]
2800 [1321]	0.99	0.98	1.00	0.07 [.02]	0.36 [0.09]	0.85 [.21]	0.69 [.17]	0.113 [.03]	0.078 [.02]
2900 [1368]	1.00	1.00	1.00	0.08 [.02]	0.39 [0.10]	0.91 [.23]	0.74 [.18]	0.117 [.03]	0.085 [.02]
3000 [1416]	1.01	1.01	1.00	0.08 [.02]	0.43 [0.11]	0.96 [.24]	0.79 [.20]	0.122 [.03]	0.093 [.02]
3100 [1463]	1.01	1.03	1.00	0.09 [.02]	0.47 [0.12]	1.02 [.25]	0.86 [.21]	0.127 [.03]	0.100 [.02]

*Multiply correction factor times gross performance data resulting sensible capacity cannot exceed total capacity.

[] Designates Metric Conversions

AIRFLOW PERFORMANCE — 6.5 TON — 60 Hz — 460V — DOWNFLOW

Air Flow	Model RHPDYC078 Voltage 460V — 3 phase 60 Hz																													
	External Static Pressure—Inches of Water [kPa]																													
	0.1 [.02]			0.2 [.05]			0.3 [.07]			0.4 [.10]			0.5 [.12]			0.6 [.15]			0.7 [.17]			0.8 [.20]			0.9 [.22]			1.0 [.25]		
	RPM	W	%	RPM	W	%	RPM	W	%	RPM	W	%	RPM	W	%	RPM	W	%	RPM	W	%	RPM	W	%	RPM	W	%	RPM	W	%
2100 [991]	675	205	25.70	724	249	27.7	767	290	29.6	810	334	31.3	856	385	33.1	896	432	34.9	936	486	36.5	972	533	37.9	1009	588	39.3	1043	638	40.7
2200 [1038]	701	224	26.70	749	271	28.7	788	311	30.5	831	357	32.2	871	404	33.8	912	455	35.6	952	508	37.2	991	563	38.7	1028	619	40.1	1060	670	41.4
2300 [1085]	725	243	27.70	767	288	29.5	812	335	31.5	850	379	33.0	892	430	34.7	926	476	36.2	969	533	37.9	1008	591	39.4	1049	654	40.9	1080	707	42.2
2400 [1133]	747	261	28.60	790	307	30.5	833	355	32.4	876	408	34.0	912	455	35.5	943	501	36.9	984	557	38.5	1026	622	40.1	1068	687	41.7	1098	741	43.0
2500 [1180]	773	283	29.60	813	331	31.5	852	377	33.2	898	436	34.9	931	481	36.3	965	535	37.8	1002	588	39.2	1045	655	40.8	1086	722	42.4	1120	784	43.9
2600 [1227]	800	309	30.70	837	355	32.5	882	411	34.3	916	459	35.7	954	516	37.2	983	561	38.5	1018	615	39.9	1062	686	41.5	1104	759	43.2	1139	820	44.7
2700 [1274]	821	330	31.60	859	378	33.4	905	440	35.2	941	493	36.7	977	547	38.1	1003	594	39.3	1037	649	40.7	1076	714	42.1	1120	788	43.9	1155	854	45.4
2800 [1321]	847	355	32.70	886	408	34.5	927	470	36.1	962	522	37.5	998	580	39.0	1023	625	40.1	1055	681	41.4	1095	751	42.9	1136	824	44.6	1171	892	46.1
2900 [1368]	873	383	33.80	908	436	35.4	947	496	36.9	984	554	38.4	1018	611	39.8	1043	659	40.9	1083	728	42.4	1115	790	43.7	1152	860	45.3	1187	932	46.8
3000 [1416]	899	415	34.90	936	471	36.5	974	533	38.0	1007	589	39.3	1041	647	40.7	1062	693	41.7	1104	766	43.2	1136	830	44.6	1173	902	46.2	1205	971	47.5
3100 [1463]	922	441	35.80	959	500	37.4	991	558	38.7	1025	621	40.1	1061	682	41.5	1094	745	42.8	1124	806	44.1	1158	875	45.5	1191	944	47.0	1226	1021	48.4

Air Flow	Model RHPDYC078 Voltage 460V — 3 phase 60 Hz																													
	External Static Pressure—Inches of Water [kPa]																													
	1.1 [.27]			1.2 [.30]			1.3 [.32]			1.4 [.35]			1.5 [.37]			1.6 [.40]			1.7 [.42]			1.8 [.45]			1.9 [.47]			2.0 [.50]		
	RPM	W	%	RPM	W	%	RPM	W	%	RPM	W	%	RPM	W	%	RPM	W	%	RPM	W	%	RPM	W	%	RPM	W	%	RPM	W	%
2100 [991]	1074	688	41.9	1105	744	43.1	1134	799	44.3	1154	841	45.4	1188	902	46.7	1208	952	47.6	1231	1007	48.5	1246	1047	49.3	1271	1100	50.3	1303	1167	51.4
2200 [1038]	1095	730	42.8	1123	781	43.9	1153	840	45.2	1170	878	46.1	1207	948	47.5	1221	987	48.2	1245	1042	49.1	1261	1084	49.9	1287	1145	51.0	1317	1213	52.0
2300 [1085]	1113	767	43.6	1142	820	44.7	1171	879	46.0	1188	920	46.9	1224	988	48.3	1239	1033	48.9	1261	1085	49.8	1278	1134	50.6	1302	1188	51.6	1337	1269	52.7
2400 [1133]	1132	805	44.4	1164	865	45.6	1189	918	46.8	1208	964	47.7	1241	1036	49.0	1256	1079	49.6	1278	1135	50.5	1294	1177	51.3	1318	1237	52.2	1349	1310	53.2
2500 [1180]	1150	842	45.2	1183	907	46.5	1207	963	47.6	1224	1005	48.4	1260	1083	49.8	1273	1124	50.3	1295	1182	51.2	1310	1226	51.9	1336	1292	52.9	1367	1368	53.8
2600 [1227]	1169	884	46.0	1202	950	47.3	1226	1004	48.4	1246	1058	49.3	1279	1128	50.5	1289	1172	51.0	1313	1233	51.9	1327	1279	52.6	1359	1352	53.6	1385	1426	54.4
2700 [1274]	1188	925	46.8	1222	995	48.2	1244	1052	49.2	1265	1106	50.1	1296	1178	51.3	1310	1228	51.8	1329	1281	52.5	1343	1328	53.2	1379	1412	54.2	1401	1476	54.9
2800 [1321]	1207	968	47.6	1242	1040	49.0	1264	1100	50.0	1283	1153	50.8	1316	1231	52.0	1329	1281	52.5	1344	1333	53.2	1364	1388	53.9	1398	1473	54.8	1418	1534	55.5
2900 [1368]	1223	1008	48.3	1258	1083	49.7	1281	1145	50.7	1303	1205	51.6	1329	1276	52.6	1345	1330	53.1	1359	1382	53.7	1382	1443	54.5	1413	1525	55.3	1438	1599	56.2
3000 [1416]	1238	1043	48.9	1274	1125	50.4	1298	1191	51.4	1321	1255	52.3	1347	1328	53.3	1365	1386	53.7	1376	1434	54.3	1399	1497	55.0	1432	1586	56.0	1455	1662	57.0
3100 [1463]	1257	1094	49.7	1287	1168	51.0	1321	1248	52.2	1338	1302	52.9	1366	1383	53.9	1382	1441	54.3	1394	1490	54.9	1419	1560	55.7	1452	1654	56.8	1473	1723	57.9

NOTES: 1. Factory airflow setting of VDC (%) at AHRI minimum External Static Pressure. Adjust VDC (%) value to achieve desire airflow.
 2. Do not set outside range of VDC (%) values from the values shown in Table
 3. Drive data is for Sideflow/Downflow with dry coil. Add component resistance (below) to determine total External Static Pressure

Airflow	AIRFLOW CORRECTION FACTORS*			COMPONENT AIRFLOW RESISTANCE					
				Wet Coil	Horizontal Economizer RA Damper Open	Concentric Diffuser RXRN-AEF2000 & Concentric Adapter RXMC-DD01 (Flush)	Concentric Diffuser RXRN-AED2000 & Concentric Adapter RXMC-DD01 (Drop)	Pressure Drop MERV 8	Pressure Drop MERV 13
	CFM [L/s]	Total kBtu/h	Sensible kBtu/h	Power kW	Resistance — Inches of Water [kPa]				
2400 [1133]	0.97	0.92	0.99	0.06 [.01]	0.21 [0.05]	0.66 [.16]	0.53 [.13]	0.093 [.02]	0.047 [.01]
2500 [1180]	0.97	0.93	0.99	0.06 [.01]	0.25 [0.06]	0.71 [.18]	0.57 [.14]	0.098 [.02]	0.055 [.01]
2600 [1227]	0.98	0.95	0.99	0.06 [.02]	0.28 [0.07]	0.75 [.19]	0.60 [.15]	0.103 [.02]	0.062 [.01]
2700 [1274]	0.99	0.96	0.99	0.07 [.02]	0.32 [0.08]	0.80 [.20]	0.65 [.16]	0.108 [.03]	0.070 [.02]
2800 [1321]	0.99	0.98	1.00	0.07 [.02]	0.36 [0.09]	0.85 [.21]	0.69 [.17]	0.113 [.03]	0.078 [.02]
2900 [1368]	1.00	1.00	1.00	0.08 [.02]	0.39 [0.10]	0.91 [.23]	0.74 [.18]	0.117 [.03]	0.085 [.02]
3000 [1416]	1.01	1.01	1.00	0.08 [.02]	0.43 [0.11]	0.96 [.24]	0.79 [.20]	0.122 [.03]	0.093 [.02]
3100 [1463]	1.01	1.03	1.00	0.09 [.02]	0.47 [0.12]	1.02 [.25]	0.86 [.21]	0.127 [.03]	0.100 [.02]

*Multiply correction factor times gross performance data resulting sensible capacity cannot exceed total capacity.

[] Designates Metric Conversions

AIRFLOW PERFORMANCE — 6.5 TON — 60 Hz — 460V — SIDEFLOW

Air Flow	Model RHPDYC078 Voltage 460V — 3 phase 60 Hz																															
	External Static Pressure—Inches of Water [kPa]																															
	0.1 [.02]			0.2 [.05]			0.3 [.07]			0.4 [.10]			0.5 [.12]			0.6 [.15]			0.7 [.17]			0.8 [.20]			0.9 [.22]			1.0 [.25]				
RPM	W	%	RPM	W	%	RPM	W	%	RPM	W	%	RPM	W	%	RPM	W	%	RPM	W	%	RPM	W	%	RPM	W	%	RPM	W	%	RPM	W	%
2100 [991]	667	194	25.4	723	240	27.7	760	275	29.3	803	319	31.00	842	364	32.60	874	404	34.00	918	455	35.70	960	513	37.40	994	562	38.70	1026	612	40.00		
2200 [1038]	688	208	26.2	746	258	28.6	783	295	30.3	823	339	31.80	859	382	33.30	893	428	34.80	934	479	36.40	974	533	38.00	1009	586	39.40	1042	641	40.70		
2300 [1085]	712	225	27.2	768	276	29.5	804	315	31.2	842	359	32.60	873	402	33.90	914	454	35.70	948	500	37.00	985	554	38.50	1027	616	40.10	1057	665	41.30		
2400 [1133]	741	245	28.3	789	295	30.3	828	338	32.1	863	382	33.40	894	427	34.80	927	471	36.20	968	529	37.80	1004	586	39.20	1041	643	40.70	1073	695	42.00		
2500 [1180]	763	264	29.2	808	312	31.2	847	359	32.9	881	405	34.20	912	449	35.60	947	498	37.00	985	554	38.50	1023	617	40.00	1054	670	41.20	1088	726	42.60		
2600 [1227]	785	282	30.1	830	333	32.1	873	388	33.9	902	428	35.00	932	474	36.40	970	529	37.90	1003	582	39.20	1041	644	40.70	1070	699	41.90	1099	753	43.10		
2700 [1274]	812	306	31.2	852	354	33.0	894	412	34.7	924	455	35.90	952	502	37.20	988	557	38.60	1026	617	40.10	1059	675	41.40	1091	736	42.70	1114	786	43.80		
2800 [1321]	838	330	32.3	876	381	34.0	919	440	35.7	945	484	36.80	972	530	38.00	1009	587	39.40	1043	644	40.80	1079	709	42.20	1108	768	43.40	1134	825	44.60		
2900 [1368]	864	355	33.3	899	407	34.9	943	468	36.6	968	513	37.70	990	556	38.70	1031	620	40.30	1066	682	41.70	1098	744	43.00	1125	800	44.10	1151	859	45.30		
3000 [1416]	890	382	34.4	925	437	36.0	963	494	37.4	991	547	38.60	1012	588	39.60	1052	654	41.10	1082	712	42.40	1116	779	43.80	1147	841	45.10	1172	901	46.20		
3100 [1463]	914	408	35.4	948	466	36.9	985	526	38.3	1014	579	39.50	1035	622	40.50	1072	686	41.90	1102	747	43.20	1136	817	44.60	1167	882	45.90	1194	943	47.10		

Air Flow	Model RHPDYC078 Voltage 460V — 3 phase 60 Hz																															
	External Static Pressure—Inches of Water [kPa]																															
	1.1 [.27]			1.2 [.30]			1.3 [.32]			1.4 [.35]			1.5 [.37]			1.6 [.40]			1.7 [.42]			1.8 [.45]			1.9 [.47]			2.0 [.50]				
RPM	W	%	RPM	W	%	RPM	W	%	RPM	W	%	RPM	W	%	RPM	W	%	RPM	W	%	RPM	W	%	RPM	W	%	RPM	W	%	RPM	W	%
2100 [991]	1053	656	41.10	1089	722	42.50	1110	758	43.40	1132	801	44.60	1159	853	45.60	1187	906	46.70	1214	964	47.80	1238	1013	48.80	1264	1071	49.80	1286	1129	50.80		
2200 [1038]	1069	687	41.80	1099	741	43.00	1123	787	44.00	1148	839	45.20	1175	890	46.30	1203	946	47.40	1226	999	48.40	1252	1054	49.50	1280	1116	50.50	1301	1169	51.40		
2300 [1085]	1088	720	42.50	1115	775	43.70	1139	820	44.70	1164	873	45.80	1190	925	47.00	1219	986	48.10	1242	1040	49.10	1266	1092	50.10	1294	1156	51.10	1317	1214	52.00		
2400 [1133]	1104	752	43.20	1130	804	44.30	1154	855	45.40	1180	911	46.50	1207	967	47.70	1236	1028	48.80	1258	1082	49.70	1283	1141	50.80	1308	1199	51.70	1329	1256	52.50		
2500 [1180]	1120	785	43.90	1147	840	45.10	1171	893	46.10	1198	950	47.30	1223	1008	48.40	1250	1066	49.40	1274	1124	50.40	1304	1195	51.60	1327	1255	52.40	1346	1306	53.10		
2600 [1227]	1137	820	44.60	1164	876	45.80	1189	933	46.90	1213	988	48.00	1239	1048	49.10	1269	1114	50.20	1292	1173	51.10	1322	1245	52.20	1344	1305	53.00	1360	1352	53.60		
2700 [1274]	1149	851	45.20	1177	908	46.40	1206	971	47.60	1232	1033	48.80	1255	1086	49.70	1286	1161	50.90	1307	1218	51.70	1336	1286	52.70	1357	1348	53.50	1377	1404	54.20		
2800 [1321]	1163	885	45.80	1190	943	47.00	1221	1008	48.30	1249	1075	49.50	1272	1129	50.40	1302	1202	51.50	1322	1259	52.30	1355	1343	53.40	1375	1402	54.10	1394	1458	54.70		
2900 [1368]	1181	924	46.60	1203	977	47.50	1232	1045	48.80	1266	1117	50.20	1293	1183	51.20	1317	1244	52.10	1342	1313	53.00	1370	1389	53.90	1391	1452	54.60	1412	1514	55.30		
3000 [1416]	1198	962	47.30	1219	1018	48.30	1246	1081	49.40	1276	1151	50.60	1309	1228	51.80	1336	1297	52.80	1360	1369	53.60	1385	1437	54.40	1406	1500	55.10	1428	1569	55.90		
3100 [1463]	1214	997	48.00	1237	1059	49.00	1262	1123	50.10	1289	1192	51.20	1319	1267	52.20	1349	1338	53.30	1374	1410	54.10	1401	1484	54.90	1423	1555	55.70	1443	1621	56.50		

- NOTES:** 1. Factory airflow setting of VDC (%) at AHRI minimum External Static Pressure. Adjust VDC (%) value to achieve desire airflow.
 2. Do not set outside range of VDC (%) values from the values shown in Table
 3. Drive data is for Sideflow/Downflow with dry coil. Add component resistance (below) to determine total External Static Pressure

Airflow	AIRFLOW CORRECTION FACTORS*			COMPONENT AIRFLOW RESISTANCE					
				Wet Coil	Horizontal Economizer RA Damper Open	Concentric Diffuser RXRN-AEF2000 & Concentric Adapter RXMC-DD01 (Flush)	Concentric Diffuser RXRN-AED2000 & Concentric Adapter RXMC-DD01 (Drop)	Pressure Drop MERV 8	Pressure Drop MERV 13
CFM [L/s]	Total kBtu/h	Sensible kBtu/h	Power kW	Resistance — Inches of Water [kPa]					
2400 [1133]	0.97	0.92	0.99	0.06 [.01]	0.21 [0.05]	0.66 [.16]	0.53 [.13]	0.093 [.02]	0.047 [.01]
2500 [1180]	0.97	0.93	0.99	0.06 [.01]	0.25 [0.06]	0.71 [.18]	0.57 [.14]	0.098 [.02]	0.055 [.01]
2600 [1227]	0.98	0.95	0.99	0.06 [.02]	0.28 [0.07]	0.75 [.19]	0.60 [.15]	0.103 [.02]	0.062 [.01]
2700 [1274]	0.99	0.96	0.99	0.07 [.02]	0.32 [0.08]	0.80 [.20]	0.65 [.16]	0.108 [.03]	0.070 [.02]
2800 [1321]	0.99	0.98	1.00	0.07 [.02]	0.36 [0.09]	0.85 [.21]	0.69 [.17]	0.113 [.03]	0.078 [.02]
2900 [1368]	1.00	1.00	1.00	0.08 [.02]	0.39 [0.10]	0.91 [.23]	0.74 [.18]	0.117 [.03]	0.085 [.02]
3000 [1416]	1.01	1.01	1.00	0.08 [.02]	0.43 [0.11]	0.96 [.24]	0.79 [.20]	0.122 [.03]	0.093 [.02]
3100 [1463]	1.01	1.03	1.00	0.09 [.02]	0.47 [0.12]	1.02 [.25]	0.86 [.21]	0.127 [.03]	0.100 [.02]

*Multiply correction factor times gross performance data resulting sensible capacity cannot exceed total capacity.

[] Designates Metric Conversions

AIRFLOW PERFORMANCE — 7.5 TON — 60 Hz — 208/230V — DOWNFLOW

Air Flow	Model RHPDYC090 Voltage 208/230V — 3 phase 60 Hz																															
	External Static Pressure—Inches of Water [kPa]																															
	0.1 [.02]			0.2 [.05]			0.3 [.07]			0.4 [.10]			0.5 [.12]			0.6 [.15]			0.7 [.17]			0.8 [.20]			0.9 [.22]			1.0 [.25]				
RPM	W	%	RPM	W	%	RPM	W	%	RPM	W	%	RPM	W	%	RPM	W	%	RPM	W	%	RPM	W	%	RPM	W	%	RPM	W	%	RPM	W	%
2400 [1133]	723	207	30.8	774	258	33.2	821	308	35.1	864	360	36.8	906	413	38.7	946	469	40.4	981	524	41.9	1012	577	43.6	1047	638	45.3	1081	698	46.8		
2500 [1180]	748	223	31.9	797	276	34.2	844	329	36.1	886	382	37.8	927	437	39.6	966	495	41.3	1000	551	42.8	1030	606	44.4	1065	668	46.1	1099	730	47.5		
2600 [1227]	772	241	32.9	820	296	35.1	867	351	37.1	908	406	38.8	948	463	40.6	986	523	42.3	1020	580	43.7	1049	636	45.2	1083	699	46.8	1117	763	48.2		
2700 [1274]	796	261	34.0	843	317	36.1	889	375	38.1	930	432	39.8	969	490	41.6	1007	552	43.2	1039	611	44.6	1068	668	46.0	1102	732	47.6	1135	798	48.9		
2800 [1321]	821	282	35.0	866	340	37.2	912	400	39.1	952	459	40.8	991	520	42.5	1027	583	44.1	1059	643	45.5	1088	702	46.9	1121	767	48.3	1153	834	49.7		
2900 [1368]	845	305	36.1	890	365	38.2	935	427	40.1	974	488	41.8	1012	550	43.5	1048	615	45.0	1078	676	46.4	1107	737	47.7	1139	804	49.1	1172	873	50.5		
3000 [1416]	869	330	37.1	913	391	39.2	958	456	41.1	997	518	42.8	1034	583	44.4	1069	649	46.0	1098	712	47.3	1127	774	48.6	1159	842	49.9	1190	913	51.3		
3100 [1463]	894	356	38.2	936	418	40.2	981	486	42.1	1019	550	43.8	1055	616	45.4	1090	685	46.9	1118	748	48.2	1146	812	49.5	1178	882	50.8	1209	954	52.1		
3200 [1510]	918	383	39.3	960	447	41.2	1004	517	43.1	1041	584	44.8	1077	652	46.4	1111	722	47.8	1138	787	49.1	1166	852	50.4	1197	923	51.6	1228	997	52.9		
3300 [1557]	943	412	40.3	983	478	42.2	1027	551	44.1	1064	619	45.8	1099	689	47.3	1132	761	48.8	1158	826	50.0	1186	894	51.3	1217	966	52.5	1247	1042	53.8		
3400 [1604]	967	443	41.4	1006	510	43.2	1050	585	45.1	1086	656	46.7	1121	728	48.3	1154	802	49.7	1179	868	50.9	1207	937	52.2	1237	1011	53.4	1267	1089	54.6		
3500 [1652]	992	475	42.5	1030	544	44.2	1073	622	46.1	1109	694	47.7	1143	768	49.2	1175	844	50.7	1199	911	51.9	1227	982	53.1	1257	1057	54.2	1286	1137	55.5		
3600 [1699]	1016	509	43.5	1054	579	45.3	1096	659	47.1	1132	734	48.7	1165	810	50.2	1197	888	51.6	1220	955	52.8	1248	1029	54.0	1277	1105	55.2	1306	1186	56.5		

Air Flow	Model RHPDYC090 Voltage 208/230V — 3 phase 60 Hz																																		
	External Static Pressure—Inches of Water [kPa]																																		
	1.1 [.27]			1.2 [.30]			1.3 [.32]			1.4 [.35]			1.5 [.37]			1.6 [.40]			1.7 [.42]			1.8 [.45]			1.9 [.47]			2.0 [.50]							
RPM	W	%	RPM	W	%	RPM	W	%	RPM	W	%	RPM	W	%	RPM	W	%	RPM	W	%	RPM	W	%	RPM	W	%	RPM	W	%	RPM	W	%	RPM	W	%
2400 [1133]	1115	766	48.7	1147	826	50.0	1177	885	51.2	1206	953	52.5	1235	1016	53.5	1265	1082	54.5	1294	1155	55.2	1320	1227	55.0	1347	1291	56.4	1371	1352	57.9					
2500 [1180]	1132	798	49.2	1164	860	50.5	1193	921	51.7	1222	990	53.1	1251	1055	54.1	1282	1123	55.2	1311	1197	56.0	1336	1270	56.1	1362	1337	57.5	1387	1403	58.9					
2600 [1227]	1149	831	49.8	1181	896	51.1	1210	959	52.4	1239	1028	53.7	1268	1095	54.8	1298	1166	56.0	1327	1241	56.8	1352	1315	57.1	1379	1385	58.6	1403	1455	60.0					
2700 [1274]	1167	867	50.5	1198	933	51.8	1227	998	53.0	1256	1068	54.3	1284	1138	55.5	1315	1211	56.7	1343	1287	57.7	1368	1361	58.1	1395	1436	59.6	1420	1509	61.1					
2800 [1321]	1185	904	51.2	1215	972	52.5	1244	1040	53.7	1273	1110	55.0	1301	1182	56.2	1332	1258	57.5	1360	1335	58.5	1385	1410	59.2	1411	1488	60.7	1436	1565	62.1					
2900 [1368]	1202	943	51.9	1233	1013	53.2	1262	1083	54.4	1290	1154	55.7	1318	1228	57.0	1349	1307	58.3	1377	1385	59.4	1401	1461	60.2	1428	1542	61.7	1453	1623	63.2					
3000 [1416]	1221	984	52.6	1251	1056	53.9	1279	1127	55.1	1307	1200	56.5	1335	1276	57.7	1367	1357	59.1	1393	1436	60.3	1418	1514	61.2	1444	1597	62.8	1470	1682	64.3					
3100 [1463]	1239	1026	53.4	1269	1101	54.7	1297	1174	55.9	1325	1248	57.3	1353	1325	58.5	1384	1410	60.0	1411	1490	61.2	1435	1569	62.3	1461	1655	63.8	1487	1743	65.3					
3200 [1510]	1257	1071	54.1	1287	1147	55.5	1315	1222	56.7	1343	1298	58.1	1370	1377	59.4	1402	1464	60.9	1428	1545	62.1	1452	1625	63.3	1478	1715	64.9	1504	1806	66.4					
3300 [1557]	1276	1117	55.0	1306	1195	56.3	1333	1272	57.6	1361	1349	58.9	1388	1430	60.2	1420	1520	61.8	1445	1603	63.1	1469	1684	64.3	1495	1776	65.9	1521	1870	67.4					
3400 [1604]	1295	1165	55.8	1324	1245	57.1	1352	1324	58.4	1379	1403	59.8	1406	1486	61.1	1438	1578	62.7	1463	1662	64.0	1487	1745	65.4	1512	1840	66.9	1538	1936	68.5					
3500 [1652]	1314	1214	56.7	1343	1296	58.0	1370	1377	59.3	1398	1458	60.7	1424	1543	62.1	1456	1638	63.6	1481	1723	65.0	1504	1807	66.4	1530	1905	68.0	1556	2004	69.5					
3600 [1699]	1334	1266	57.6	1362	1350	59.0	1389	1433	60.3	1416	1515	61.6	1442	1602	63.0	1474	1700	64.6	1499	1786	66.0	1522	1872	67.5	1547	1972	69.0	1573	2074	70.5					

- NOTES: 1. Factory airflow setting of VDC (%) at AHRI minimum External Static Pressure. Adjust VDC (%) value to achieve desire airflow.
 2. Do not set outside range of VDC (%) values from the values shown in Table
 3. Drive data is for Sideflow/Downflow with dry coil. Add component resistance (below) to determine total External Static Pressure

Airflow	COMPONENT AIRFLOW RESISTANCE									
	AIRFLOW CORRECTION FACTORS*				Wet Coil	Horizontal Economizer RA Damper Open	Concentric Diffuser RXRN-AEF2000 & Concentric Adapter RXMC-DD01 (Flush)	Concentric Diffuser RXRN-AED2000 & Concentric Adapter RXMC-DD01 (Drop)	Pressure Drop MERV 8	Pressure Drop MERV 13
	CFM [L/s]	Total kBtu/h	Sensible kBtu/h	Power kW						
2400 [1133]	0.97	0.92	0.99	0.06 [.01]	0.21 [0.05]	0.66 [.16]	0.53 [.13]	0.093 [.02]	0.047 [.01]	
2500 [1180]	0.97	0.93	0.99	0.06 [.01]	0.25 [0.06]	0.71 [.18]	0.57 [.14]	0.098 [.02]	0.055 [.01]	
2600 [1227]	0.98	0.95	0.99	0.06 [.02]	0.28 [0.07]	0.75 [.19]	0.60 [.15]	0.103 [.02]	0.062 [.01]	
2700 [1274]	0.99	0.96	0.99	0.07 [.02]	0.32 [0.08]	0.80 [.20]	0.65 [.16]	0.108 [.03]	0.070 [.02]	
2800 [1321]	0.99	0.98	1.00	0.07 [.02]	0.36 [0.09]	0.85 [.21]	0.69 [.17]	0.113 [.03]	0.078 [.02]	
2900 [1368]	1.00	1.00	1.00	0.08 [.02]	0.39 [0.10]	0.91 [.23]	0.74 [.18]	0.117 [.03]	0.085 [.02]	
3000 [1416]	1.01	1.01	1.00	0.08 [.02]	0.43 [0.11]	0.96 [.24]	0.79 [.20]	0.122 [.03]	0.093 [.02]	
3100 [1463]	1.01	1.03	1.00	0.09 [.02]	0.47 [0.12]	1.02 [.25]	0.86 [.21]	0.127 [.03]	0.100 [.02]	
3200 [1510]	1.02	1.04	1.01	0.10 [.02]	0.51 [0.13]	1.08 [.27]	0.92 [.23]	0.132 [.03]	0.108 [.03]	
3300 [1557]	1.02	1.06	1.01	0.10 [.03]	0.54 [0.14]	1.15 [.29]	0.99 [.25]	0.137 [.03]	0.115 [.03]	
3400 [1604]	1.03	1.08	1.01	0.11 [.03]	0.58 [0.14]	1.21 [.30]	1.05 [.26]	0.142 [.03]	0.123 [.03]	
3500 [1652]	1.04	1.09	1.01	0.11 [.03]	0.62 [0.15]	1.29 [.32]	1.09 [.27]	0.147 [.04]	0.131 [.03]	
3600 [1699]	1.04	1.11	1.02	0.12 [.03]	0.66 [0.16]	1.36 [.34]	1.13 [.28]	0.152 [.04]	0.138 [.03]	

*Multiply correction factor times gross performance data resulting sensible capacity cannot exceed total capacity.

[] Designates Metric Conversions

AIRFLOW PERFORMANCE — 7.5 TON — 60 Hz — 208/230V — SIDEFLOW

Air Flow	Model RHPDYC090 Voltage 208/230V — 3 phase 60 Hz																																
	External Static Pressure—Inches of Water [kPa]																																
	0.1 [.02]			0.2 [.05]			0.3 [.07]			0.4 [.10]			0.5 [.12]			0.6 [.15]			0.7 [.17]			0.8 [.20]			0.9 [.22]			1.0 [.25]					
	RPM	W	%	RPM	W	%	RPM	W	%	RPM	W	%	RPM	W	%	RPM	W	%	RPM	W	%	RPM	W	%	RPM	W	%	RPM	W	%	RPM	W	%
2400 [1133]	709	197	30.5	755	241	32.5	795	284	34.0	837	332	35.9	872	374	37.4	915	428	39.1	952	478	40.6	990	532	42.4	1024	587	43.9	1054	641	45.5			
2500 [1180]	733	212	31.5	777	258	33.4	817	302	35.0	858	352	36.8	892	396	38.3	934	451	40.0	971	503	41.5	1008	558	43.2	1041	614	44.7	1070	667	46.2			
2600 [1227]	757	229	32.5	800	276	34.4	839	322	35.9	880	374	37.8	912	418	39.2	954	476	40.9	989	529	42.4	1025	585	44.0	1058	642	45.4	1086	695	46.8			
2700 [1274]	781	248	33.5	823	296	35.4	861	343	36.9	901	397	38.7	933	443	40.1	974	502	41.9	1008	557	43.3	1044	614	44.8	1076	673	46.2	1102	725	47.5			
2800 [1321]	806	268	34.5	846	317	36.3	883	366	37.9	923	422	39.7	953	469	41.0	994	530	42.8	1028	586	44.2	1062	645	45.7	1094	705	47.0	1119	756	48.2			
2900 [1368]	830	289	35.5	868	340	37.3	905	391	38.8	944	448	40.6	974	496	42.0	1014	560	43.7	1047	617	45.1	1080	677	46.5	1112	738	47.8	1136	790	49.0			
3000 [1416]	854	312	36.6	891	364	38.3	928	417	39.8	966	476	41.5	995	525	42.9	1034	591	44.6	1067	649	45.9	1099	711	47.3	1130	773	48.7	1153	825	49.7			
3100 [1463]	878	337	37.6	914	390	39.3	950	445	40.8	988	505	42.5	1016	556	43.8	1054	623	45.5	1086	684	46.8	1118	747	48.2	1148	810	49.5	1171	862	50.5			
3200 [1510]	902	363	38.6	938	417	40.2	973	474	41.8	1010	536	43.5	1037	588	44.7	1075	657	46.4	1106	719	47.7	1138	784	49.0	1167	848	50.3	1189	900	51.2			
3300 [1557]	927	390	39.6	961	446	41.2	996	505	42.8	1032	569	44.4	1058	622	45.7	1096	693	47.3	1127	757	48.6	1157	822	49.9	1186	888	51.2	1207	941	52.0			
3400 [1604]	951	420	40.7	984	477	42.2	1019	538	43.8	1054	603	45.4	1080	658	46.6	1117	730	48.2	1147	796	49.5	1177	863	50.8	1205	930	52.0	1225	983	52.9			
3500 [1652]	975	450	41.7	1008	509	43.2	1042	572	44.8	1076	638	46.3	1101	695	47.5	1138	769	49.2	1167	836	50.4	1197	905	51.6	1225	973	52.9	1244	1027	53.7			
3600 [1699]	1000	483	42.8	1031	542	44.3	1066	608	45.8	1099	675	47.3	1123	733	48.5	1159	810	50.1	1188	878	51.3	1217	948	52.5	1244	1018	53.8	1263	1073	54.6			

Air Flow	Model RHPDYC090 Voltage 208/230V — 3 phase 60 Hz																																			
	External Static Pressure—Inches of Water [kPa]																																			
	1.1 [.27]			1.2 [.30]			1.3 [.32]			1.4 [.32]			1.5 [.37]			1.6 [.40]			1.7 [.42]			1.8 [.45]			1.9 [.47]			2.0 [.50]								
	RPM	W	%	RPM	W	%	RPM	W	%	RPM	W	%	RPM	W	%	RPM	W	%	RPM	W	%	RPM	W	%	RPM	W	%	RPM	W	%	RPM	W	%	RPM	W	%
2400 [1133]	1090	706	47.1	1122	771	48.8	1154	833	50.1	1180	895	51.6	1202	949	52.6	1235	1014	53.5	1260	1075	54.3	1285	1136	55.1	1308	1194	55.8	1323	1232	56.4						
2500 [1180]	1106	734	47.7	1137	799	49.4	1169	862	50.6	1196	925	52.0	1217	980	53.0	1250	1048	54.1	1275	1111	55.0	1301	1175	55.8	1324	1236	56.6	1339	1279	57.3						
2600 [1227]	1122	764	48.4	1153	829	49.9	1185	893	51.2	1212	958	52.5	1232	1014	53.5	1266	1084	54.6	1291	1149	55.6	1316	1216	56.6	1340	1280	57.4	1355	1328	58.2						
2700 [1274]	1139	796	49.1	1169	860	50.5	1200	927	51.7	1228	993	53.1	1248	1050	54.1	1281	1122	55.2	1307	1189	56.3	1332	1258	57.3	1356	1325	58.2	1372	1378	59.0						
2800 [1321]	1156	829	49.8	1185	894	51.1	1217	962	52.3	1244	1029	53.6	1263	1087	54.6	1297	1162	55.8	1323	1231	57.0	1348	1302	58.1	1372	1372	59.1	1388	1429	59.9						
2900 [1368]	1173	865	50.5	1202	929	51.8	1233	999	53.0	1260	1068	54.2	1279	1126	55.2	1313	1203	56.5	1339	1275	57.7	1364	1348	58.8	1388	1421	60.0	1404	1482	60.8						
3000 [1416]	1190	902	51.2	1218	967	52.4	1249	1038	53.7	1277	1108	54.9	1295	1168	55.9	1329	1247	57.2	1355	1320	58.4	1380	1396	59.6	1404	1472	60.8	1421	1536	61.8						
3100 [1463]	1208	941	52.0	1236	1006	53.1	1266	1079	54.4	1293	1151	55.6	1312	1211	56.5	1346	1293	57.9	1371	1368	59.2	1397	1446	60.5	1421	1524	61.7	1437	1591	62.7						
3200 [1510]	1226	981	52.8	1253	1048	53.9	1283	1122	55.1	1310	1195	56.3	1328	1256	57.2	1362	1341	58.7	1388	1417	60.0	1413	1498	61.3	1438	1578	62.6	1454	1648	63.6						
3300 [1557]	1244	1024	53.6	1271	1091	54.7	1301	1167	55.9	1328	1241	57.0	1345	1303	58.0	1379	1390	59.5	1404	1468	60.8	1430	1551	62.2	1454	1634	63.5	1470	1706	64.5						
3400 [1604]	1262	1068	54.4	1289	1137	55.5	1318	1214	56.7	1345	1290	57.8	1362	1352	58.8	1396	1442	60.3	1421	1521	61.7	1446	1606	63.1	1471	1692	64.5	1487	1765	65.5						
3500 [1652]	1281	1114	55.2	1307	1184	56.3	1336	1262	57.5	1363	1340	58.7	1379	1403	59.6	1413	1495	61.2	1438	1577	62.6	1463	1663	64.0	1488	1751	65.4	1503	1825	66.4						
3600 [1699]	1299	1162	56.1	1326	1234	57.2	1354	1313	58.4	1380	1392	59.5	1396	1455	60.4	1431	1551	62.1	1455	1633	63.5	1480	1722	64.9	1505	1812	66.3	1520	1887	67.4						

- NOTES:** 1. Factory airflow setting of VDC (%) at AHRI minimum External Static Pressure. Adjust VDC (%) value to achieve desire airflow.
 2. Do not set outside range of VDC (%) values from the values shown in Table
 3. Drive data is for Sideflow/Downflow with dry coil. Add component resistance (below) to determine total External Static Pressure

Airflow	AIRFLOW CORRECTION FACTORS *			COMPONENT AIRFLOW RESISTANCE					
				Wet Coil	Horizontal Economizer RA Damper Open	Concentric Diffuser RXRN-AEF2000 & Concentric Adapter RXMC-DD01 (Flush)	Concentric Diffuser RXRN-AED2000 & Concentric Adapter RXMC-DD01 (Drop)	Pressure Drop MERV 8	Pressure Drop MERV 13
CFM [L/s]	Total kBtu/h	Sensible kBtu/h	Power kW	Resistance — Inches of Water [kPa]					
2700 [1274]	0.99	0.96	0.99	0.07 [.02]	0.32 [0.08]	0.80 [.20]	0.65 [.16]	0.108 [.03]	0.070 [.02]
2800 [1321]	0.99	0.98	1.00	0.07 [.02]	0.36 [0.09]	0.85 [.21]	0.69 [.17]	0.113 [.03]	0.078 [.02]
2900 [1368]	1.00	1.00	1.00	0.08 [.02]	0.39 [0.10]	0.91 [.23]	0.74 [.18]	0.117 [.03]	0.085 [.02]
3000 [1416]	1.01	1.01	1.00	0.08 [.02]	0.43 [0.11]	0.96 [.24]	0.79 [.20]	0.122 [.03]	0.093 [.02]
3100 [1463]	1.01	1.03	1.00	0.09 [.02]	0.47 [0.12]	1.02 [.25]	0.86 [.21]	0.127 [.03]	0.100 [.02]
3200 [1510]	1.02	1.04	1.01	0.10 [.02]	0.51 [0.13]	1.08 [.27]	0.92 [.23]	0.132 [.03]	0.108 [.03]
3300 [1557]	1.02	1.06	1.01	0.10 [.03]	0.54 [0.14]	1.15 [.29]	0.99 [.25]	0.137 [.03]	0.115 [.03]
3400 [1604]	1.03	1.08	1.01	0.11 [.03]	0.58 [0.14]	1.21 [.30]	1.05 [.26]	0.142 [.03]	0.123 [.03]
3500 [1652]	1.04	1.09	1.01	0.11 [.03]	0.62 [0.15]	1.29 [.32]	1.09 [.27]	0.147 [.04]	0.131 [.03]
3600 [1699]	1.04	1.11	1.02	0.12 [.03]	0.66 [0.16]	1.36 [.34]	1.13 [.28]	0.152 [.04]	0.138 [.03]

*Multiply correction factor times gross performance data resulting sensible capacity cannot exceed total capacity.

[] Designates Metric Conversions

AIRFLOW PERFORMANCE — 7.5 TON — 60 Hz — 460V — DOWNFLOW

Air Flow	Model RHPDYC090 Voltage 460V — 3 phase 60 Hz																																
	External Static Pressure—Inches of Water [kPa]																																
	0.1 [.02]			0.2 [.05]			0.3 [.07]			0.4 [.10]			0.5 [.12]			0.6 [.15]			0.7 [.17]			0.8 [.20]			0.9 [.22]			1.0 [.25]					
	RPM	W	%	RPM	W	%	RPM	W	%	RPM	W	%	RPM	W	%	RPM	W	%	RPM	W	%	RPM	W	%	RPM	W	%	RPM	W	%	RPM	W	%
2400 [1133]	739	248	28.1	789	302	30.0	829	348	31.8	861	389	33.2	899	438	34.7	933	483	36.3	976	545	37.7	1012	602	39.1	1040	646	40.6	1069	695	41.7			
2500 [1180]	760	264	29.0	807	319	30.8	846	364	32.6	883	414	34.2	916	460	35.5	953	510	37.1	992	568	38.5	1024	620	39.7	1050	669	40.8	1079	724	41.8			
2600 [1227]	786	285	30.0	829	340	31.7	869	390	33.5	903	437	35.0	937	487	36.4	971	537	37.8	1012	600	39.3	1041	651	40.5	1069	704	41.7	1097	758	42.7			
2700 [1274]	809	307	31.0	849	358	32.5	891	414	34.4	923	462	35.8	959	516	37.3	995	570	38.7	1030	628	40.0	1062	685	41.3	1089	736	42.4	1116	794	43.6			
2800 [1321]	834	329	32.0	873	385	33.5	914	440	35.3	943	487	36.6	980	546	38.1	1014	600	39.5	1050	661	40.8	1082	719	42.1	1109	775	43.3	1134	828	44.3			
2900 [1368]	859	354	33.0	895	408	34.5	937	468	36.2	967	519	37.6	1000	573	38.9	1036	635	40.4	1069	694	41.6	1100	752	42.8	1128	812	44.1	1155	872	45.2			
3000 [1416]	881	378	33.9	918	434	35.4	960	497	37.1	989	548	38.4	1022	607	39.8	1057	669	41.2	1083	721	42.2	1120	790	43.7	1147	851	44.9	1172	906	45.9			
3100 [1463]	903	402	34.8	946	468	36.5	982	527	38.0	1011	580	39.3	1045	641	40.7	1077	702	42.0	1104	759	43.1	1141	832	44.6	1168	893	45.8	1191	947	46.8			
3200 [1510]	929	432	35.8	965	493	37.3	1005	558	38.9	1033	613	40.2	1066	675	41.5	1100	742	42.9	1126	802	44.0	1160	868	45.4	1187	933	46.6	1210	989	47.6			
3300 [1557]	952	459	36.7	988	522	38.2	1028	592	39.8	1063	657	41.3	1088	711	42.4	1121	779	43.8	1145	836	44.8	1182	913	46.3	1206	975	47.4	1229	1033	48.4			
3400 [1604]	979	494	37.8	1013	557	39.2	1051	625	40.7	1085	691	42.1	1112	752	43.4	1143	819	44.7	1168	881	45.8	1203	959	47.2	1230	1028	48.4	1251	1084	49.3			
3500 [1652]	1004	528	38.8	1037	590	40.1	1073	660	41.6	1108	729	43.0	1131	788	44.2	1164	860	45.6	1189	923	46.7	1222	1000	48.0	1250	1073	49.2	1272	1133	50.1			
3600 [1699]	1028	559	39.7	1060	625	41.0	1096	697	42.5	1132	772	44.0	1155	831	45.2	1186	901	46.5	1210	967	47.6	1237	1037	48.7	1271	1122	50.0	1293	1183	50.9			

Air Flow	Model RHPDYC090 Voltage 460V — 3 phase 60 Hz																																
	External Static Pressure—Inches of Water [kPa]																																
	1.1 [.27]			1.2 [.30]			1.3 [.32]			1.4 [.35]			1.5 [.37]			1.6 [.40]			1.7 [.42]			1.8 [.45]			1.9 [.47]			2.0 [.50]					
	RPM	W	%	RPM	W	%	RPM	W	%	RPM	W	%	RPM	W	%	RPM	W	%	RPM	W	%	RPM	W	%	RPM	W	%	RPM	W	%	RPM	W	%
2400 [1133]	1099	751	42.9	1133	818	44.2	1164	876	45.3	1191	928	46.5	1219	986	47.6	1243	1040	48.6	1267	1094	49.5	1283	1132	50.6	1308	1190	51.5	1335	1255	52.4			
2500 [1180]	1110	784	43.2	1149	852	44.9	1181	913	46.2	1208	970	47.4	1238	1030	48.6	1260	1085	49.5	1286	1148	50.5	1305	1194	51.2	1324	1242	51.9	1349	1305	52.6			
2600 [1227]	1131	822	44.2	1164	887	45.6	1198	953	47.0	1226	1013	48.2	1257	1078	49.4	1277	1130	50.2	1303	1195	51.2	1324	1250	52.0	1341	1297	52.6	1364	1356	53.3			
2700 [1274]	1148	855	44.9	1179	921	46.3	1215	990	47.7	1246	1062	49.0	1275	1123	50.1	1294	1178	50.9	1321	1247	51.9	1341	1300	52.6	1360	1358	53.3	1382	1416	53.9			
2800 [1321]	1166	894	45.7	1195	955	47.0	1234	1034	48.5	1263	1103	49.7	1293	1169	50.8	1312	1227	51.6	1338	1298	52.5	1355	1347	53.1	1376	1406	53.8	1401	1478	54.5			
2900 [1368]	1185	933	46.5	1214	998	47.8	1251	1076	49.2	1284	1152	50.5	1313	1222	51.6	1330	1276	52.2	1359	1358	53.2	1375	1409	53.7	1395	1470	54.4	1418	1535	55.1			
3000 [1416]	1203	975	47.3	1233	1041	48.6	1268	1118	49.9	1303	1203	51.3	1330	1269	52.2	1346	1323	52.8	1375	1405	53.7	1392	1458	54.2	1414	1528	55.0	1435	1592	55.7			
3100 [1463]	1222	1018	48.1	1251	1084	49.3	1289	1170	50.7	1320	1245	51.9	1348	1317	52.8	1365	1376	53.4	1392	1454	54.2	1407	1510	54.8	1430	1581	55.6	1450	1648	56.4			
3200 [1510]	1241	1062	48.9	1270	1132	50.1	1302	1209	51.3	1341	1300	52.6	1368	1372	53.4	1380	1421	53.9	1410	1509	54.8	1424	1562	55.3	1447	1637	56.3	1469	1712	57.3			
3300 [1557]	1261	1109	49.7	1291	1184	50.9	1319	1257	52.0	1361	1357	53.3	1388	1432	54.1	1396	1474	54.4	1424	1558	55.3	1443	1625	56.1	1464	1700	57.1	1487	1776	58.3			
3400 [1604]	1281	1158	50.5	1308	1228	51.6	1337	1302	52.6	1380	1411	53.9	1404	1478	54.6	1416	1532	55.1	1439	1609	56.0	1460	1678	56.8	1481	1758	58.0	1506	1843	59.4			
3500 [1652]	1301	1209	51.3	1329	1281	52.3	1357	1360	53.3	1400	1468	54.5	1422	1533	55.2	1437	1593	55.8	1459	1670	56.8	1477	1738	57.7	1502	1826	59.2	1525	1909	60.5			
3600 [1699]	1321	1257	52.0	1353	1343	53.1	1377	1413	53.9	1418	1519	55.1	1442	1597	56.0	1457	1660	56.7	1479	1735	57.8	1498	1809	58.9	1521	1893	60.3	1543	1976	61.6			

- NOTES:** 1. Factory airflow setting of VDC (%) at AHRI minimum External Static Pressure. Adjust VDC (%) value to achieve desire airflow.
 2. Do not set outside range of VDC (%) values from the values shown in Table
 3. Drive data is for Sideflow/Downflow with dry coil. Add component resistance (below) to determine total External Static Pressure

Airflow	AIRFLOW CORRECTION FACTORS*			COMPONENT AIRFLOW RESISTANCE					
				Wet Coil	Horizontal Economizer RA Damper Open	Concentric Diffuser RXRN-AEF2000 & Concentric Adapter RXMC-DD01 (Flush)	Concentric Diffuser RXRN-AED2000 & Concentric Adapter RXMC-DD01 (Drop)	Pressure Drop MERV 8	Pressure Drop MERV 13
	CFM [L/s]	Total kBtu/h	Sensible kBtu/h	Power kW	Resistance — Inches of Water [kPa]				
2400 [1133]	0.97	0.92	0.99	0.06 [.01]	0.21 [0.05]	0.66 [.16]	0.53 [.13]	0.093 [.02]	0.047 [.01]
2500 [1180]	0.97	0.93	0.99	0.06 [.01]	0.25 [0.06]	0.71 [.18]	0.57 [.14]	0.098 [.02]	0.055 [.01]
2600 [1227]	0.98	0.95	0.99	0.06 [.02]	0.28 [0.07]	0.75 [.19]	0.60 [.15]	0.103 [.02]	0.062 [.01]
2700 [1274]	0.99	0.96	0.99	0.07 [.02]	0.32 [0.08]	0.80 [.20]	0.65 [.16]	0.108 [.03]	0.070 [.02]
2800 [1321]	0.99	0.98	1.00	0.07 [.02]	0.36 [0.09]	0.85 [.21]	0.69 [.17]	0.113 [.03]	0.078 [.02]
2900 [1368]	1.00	1.00	1.00	0.08 [.02]	0.39 [0.10]	0.91 [.23]	0.74 [.18]	0.117 [.03]	0.085 [.02]
3000 [1416]	1.01	1.01	1.00	0.08 [.02]	0.43 [0.11]	0.96 [.24]	0.79 [.20]	0.122 [.03]	0.093 [.02]
3100 [1463]	1.01	1.03	1.00	0.09 [.02]	0.47 [0.12]	1.02 [.25]	0.86 [.21]	0.127 [.03]	0.100 [.02]
3200 [1510]	1.02	1.04	1.01	0.10 [.02]	0.51 [0.13]	1.08 [.27]	0.92 [.23]	0.132 [.03]	0.108 [.03]
3300 [1557]	1.02	1.06	1.01	0.10 [.03]	0.54 [0.14]	1.15 [.29]	0.99 [.25]	0.137 [.03]	0.115 [.03]
3400 [1604]	1.03	1.08	1.01	0.11 [.03]	0.58 [0.14]	1.21 [.30]	1.05 [.26]	0.142 [.03]	0.123 [.03]
3500 [1652]	1.04	1.09	1.01	0.11 [.03]	0.62 [0.15]	1.29 [.32]	1.09 [.27]	0.147 [.04]	0.131 [.03]
3600 [1699]	1.04	1.11	1.02	0.12 [.03]	0.66 [0.16]	1.36 [.34]	1.13 [.28]	0.152 [.04]	0.138 [.03]

*Multiply correction factor times gross performance data resulting sensible capacity cannot exceed total capacity.

[] Designates Metric Conversions

AIRFLOW PERFORMANCE — 7.5 TON — 60 Hz — 460V — SIDEFLOW

Air Flow	Model RHPDYC090 Voltage 460V — 3 phase 60 Hz																																
	External Static Pressure—Inches of Water [kPa]																																
	0.1 [.02]			0.2 [.05]			0.3 [.07]			0.4 [.10]			0.5 [.12]			0.6 [.15]			0.7 [.17]			0.8 [.20]			0.9 [.22]			1.0 [.25]					
	RPM	W	%	RPM	W	%	RPM	W	%	RPM	W	%	RPM	W	%	RPM	W	%	RPM	W	%	RPM	W	%	RPM	W	%	RPM	W	%	RPM	W	%
2400 [1133]	719	231	27.3	767	278	29.4	812	326	31.1	854	374	32.8	892	424	34.4	923	468	35.7	953	510	36.9	987	560	38.5	1023	618	39.5	1056	672	40.8			
2500 [1180]	741	246	28.2	789	295	30.3	834	349	32.1	872	396	33.6	911	447	35.2	943	494	36.5	970	536	37.7	1006	591	39.2	1040	646	40.3	1075	703	41.7			
2600 [1227]	768	269	29.3	816	320	31.4	857	371	33.0	894	420	34.5	933	474	36.1	961	518	37.3	989	563	38.5	1024	620	39.9	1055	672	41.0	1091	734	42.4			
2700 [1274]	790	286	30.2	841	344	32.4	875	390	33.8	916	447	35.4	952	498	36.8	981	547	38.1	1009	594	39.3	1046	654	40.7	1071	701	41.7	1109	768	43.2			
2800 [1321]	814	307	31.2	863	365	33.3	898	416	34.7	937	472	36.2	973	528	37.7	1002	577	38.9	1034	630	40.2	1064	684	41.4	1090	737	42.5	1129	805	44.0			
2900 [1368]	845	335	32.4	886	389	34.2	922	443	35.6	956	497	37.0	993	554	38.5	1022	608	39.7	1055	664	41.0	1085	720	42.2	1108	771	43.3	1147	841	44.8			
3000 [1416]	868	358	33.3	909	414	35.1	944	470	36.5	977	524	37.8	1014	585	39.3	1042	638	40.5	1073	694	41.7	1104	755	43.0	1125	804	44.0	1166	880	45.6			
3100 [1463]	890	380	34.2	941	450	36.3	966	498	37.4	1000	555	38.7	1038	618	40.2	1062	671	41.3	1094	729	42.5	1124	790	43.8	1144	839	44.8	1185	920	46.4			
3200 [1510]	917	411	35.3	963	475	37.1	989	528	38.3	1021	584	39.5	1060	654	41.1	1083	704	42.1	1115	766	43.4	1145	831	44.7	1165	881	45.7	1204	962	47.2			
3300 [1557]	943	440	36.3	985	504	38.0	1011	558	39.2	1047	622	40.5	1081	686	41.9	1101	735	42.8	1135	802	44.2	1160	863	45.4	1184	920	46.5	1223	1003	48.0			
3400 [1604]	968	471	37.3	1007	535	38.9	1034	590	40.1	1066	653	41.3	1106	726	42.9	1124	776	43.8	1155	841	45.1	1182	904	46.3	1202	958	47.3	1240	1041	48.7			
3500 [1652]	986	492	38.0	1034	569	39.9	1062	629	41.1	1090	690	42.2	1131	767	43.9	1143	809	44.6	1177	882	46.0	1208	954	47.3	1224	1005	48.2	1260	1087	49.5			
3600 [1699]	1014	529	39.1	1059	605	40.9	1085	664	42.0	1115	730	43.2	1152	804	44.8	1165	851	45.5	1195	921	46.8	1228	996	48.2	1245	1050	49.0	1277	1129	50.2			

Air Flow	Model RHPDYC090 Voltage 460V — 3 phase 60 Hz																																
	External Static Pressure—Inches of Water [kPa]																																
	1.1 [.27]			1.2 [.30]			1.3 [.32]			1.4 [.35]			1.5 [.37]			1.6 [.40]			1.7 [.42]			1.8 [.45]			1.9 [.47]			2.0 [.50]					
	RPM	W	%	RPM	W	%	RPM	W	%	RPM	W	%	RPM	W	%	RPM	W	%	RPM	W	%	RPM	W	%	RPM	W	%	RPM	W	%	RPM	W	%
2400 [1133]	1083	721	42.0	1112	777	43.2	1142	833	44.3	1169	881	45.6	1194	932	46.6	1221	987	47.7	1248	1044	48.9	1269	1101	49.7	1289	1145	50.5	1324	1224	51.8			
2500 [1180]	1100	752	42.8	1128	809	44.0	1155	861	45.1	1182	917	46.3	1209	968	47.4	1233	1021	48.5	1265	1089	49.7	1279	1129	50.3	1306	1192	51.4	1338	1267	52.4			
2600 [1227]	1119	789	43.7	1143	842	44.7	1174	903	45.9	1198	954	47.0	1225	1012	48.1	1247	1059	49.1	1279	1130	50.3	1294	1171	51.0	1322	1235	52.0	1353	1320	53.0			
2700 [1274]	1134	820	44.4	1161	877	45.5	1190	938	46.6	1217	1001	47.8	1243	1059	48.9	1264	1107	49.8	1294	1173	50.9	1309	1216	51.6	1339	1285	52.6	1368	1371	53.5			
2800 [1321]	1157	864	45.3	1177	914	46.2	1206	975	47.3	1233	1039	48.5	1260	1102	49.6	1282	1156	50.5	1311	1227	51.6	1329	1273	52.3	1357	1338	53.2	1384	1420	54.0			
2900 [1368]	1177	905	46.1	1195	953	47.0	1224	1018	48.1	1248	1076	49.1	1278	1148	50.3	1299	1204	51.2	1330	1283	52.3	1347	1330	52.9	1372	1392	53.7	1403	1483	54.6			
3000 [1416]	1193	940	46.8	1213	990	47.7	1241	1057	48.8	1268	1123	49.9	1294	1191	51.0	1315	1247	51.8	1346	1325	52.8	1366	1382	53.4	1389	1451	54.3	1414	1526	55.0			
3100 [1463]	1213	982	47.6	1231	1035	48.5	1258	1098	49.5	1286	1169	50.6	1310	1232	51.6	1335	1302	52.5	1361	1369	53.3	1383	1435	54.0	1408	1508	54.9	1429	1579	55.6			
3200 [1510]	1231	1026	48.4	1249	1076	49.2	1275	1142	50.2	1303	1212	51.3	1330	1284	52.3	1349	1341	53.0	1379	1423	53.9	1399	1483	54.5	1426	1566	55.5	1444	1636	56.3			
3300 [1557]	1252	1072	49.2	1265	1115	49.9	1293	1187	50.9	1322	1262	52.0	1347	1330	52.9	1367	1395	53.6	1399	1482	54.5	1419	1547	55.2	1442	1630	56.2	1462	1697	57.1			
3400 [1604]	1268	1113	49.9	1287	1167	50.7	1311	1233	51.6	1339	1308	52.6	1366	1384	53.5	1387	1450	54.2	1414	1527	55.0	1434	1593	55.7	1460	1689	57.0	1481	1764	58.1			
3500 [1652]	1289	1163	50.7	1305	1213	51.4	1330	1286	52.3	1358	1358	53.2	1383	1430	54.0	1405	1501	54.8	1431	1580	55.6	1453	1653	56.5	1482	1754	58.1	1499	1823	59.1			
3600 [1699]	1307	1208	51.4	1324	1264	52.1	1348	1333	52.9	1377	1413	53.8	1402	1486	54.6	1423	1553	55.3	1448	1633	56.3	1469	1708	57.3	1499	1815	59.1	1512	1875	59.9			

- NOTES:** 1. Factory airflow setting of VDC (%) at AHRI minimum External Static Pressure. Adjust VDC (%) value to achieve desire airflow.
 2. Do not set outside range of VDC (%) values from the values shown in Table
 3. Drive data is for Sideflow/Downflow with dry coil. Add component resistance (below) to determine total External Static Pressure

Airflow	AIRFLOW CORRECTION FACTORS *			COMPONENT AIRFLOW RESISTANCE					
				Wet Coil	Horizontal Economizer RA Damper Open	Concentric Diffuser RXRN-AEF2000 & Concentric Adapter RXMC-DD01 (Flush)	Concentric Diffuser RXRN-AED2000 & Concentric Adapter RXMC-DD01 (Drop)	Pressure Drop MERV 8	Pressure Drop MERV 13
CFM [L/s]	Total kBtu/h	Sensible kBtu/h	Power kW	Resistance — Inches of Water [kPa]					
2700 [1274]	0.99	0.96	0.99	0.07 [.02]	0.32 [0.08]	0.80 [.20]	0.65 [.16]	0.108 [.03]	0.070 [.02]
2800 [1321]	0.99	0.98	1.00	0.07 [.02]	0.36 [0.09]	0.85 [.21]	0.69 [.17]	0.113 [.03]	0.078 [.02]
2900 [1368]	1.00	1.00	1.00	0.08 [.02]	0.39 [0.10]	0.91 [.23]	0.74 [.18]	0.117 [.03]	0.085 [.02]
3000 [1416]	1.01	1.01	1.00	0.08 [.02]	0.43 [0.11]	0.96 [.24]	0.79 [.20]	0.122 [.03]	0.093 [.02]
3100 [1463]	1.01	1.03	1.00	0.09 [.02]	0.47 [0.12]	1.02 [.25]	0.86 [.21]	0.127 [.03]	0.100 [.02]
3200 [1510]	1.02	1.04	1.01	0.10 [.02]	0.51 [0.13]	1.08 [.27]	0.92 [.23]	0.132 [.03]	0.108 [.03]
3300 [1557]	1.02	1.06	1.01	0.10 [.03]	0.54 [0.14]	1.15 [.29]	0.99 [.25]	0.137 [.03]	0.115 [.03]
3400 [1604]	1.03	1.08	1.01	0.11 [.03]	0.58 [0.14]	1.21 [.30]	1.05 [.26]	0.142 [.03]	0.123 [.03]
3500 [1652]	1.04	1.09	1.01	0.11 [.03]	0.62 [0.15]	1.29 [.32]	1.09 [.27]	0.147 [.04]	0.131 [.03]
3600 [1699]	1.04	1.11	1.02	0.12 [.03]	0.66 [0.16]	1.36 [.34]	1.13 [.28]	0.152 [.04]	0.138 [.03]

*Multiply correction factor times gross performance data resulting sensible capacity cannot exceed total capacity.

[] Designates Metric Conversions

AIRFLOW PERFORMANCE — 8.5 TON — 60 Hz — 208/230V — DOWNFLOW

Air Flow	Model RHPDYC0102 Voltage 208/230V — 3 phase 60 Hz																																
	External Static Pressure—Inches of Water [kPa]																																
	0.1 [.02]			0.2 [.05]			0.3 [.07]			0.4 [.10]			0.5 [.12]			0.6 [.15]			0.7 [.17]			0.8 [.20]			0.9 [.22]			1.0 [.25]					
	RPM	W	%	RPM	W	%	RPM	W	%	RPM	W	%	RPM	W	%	RPM	W	%	RPM	W	%	RPM	W	%	RPM	W	%	RPM	W	%	RPM	W	%
2700 [1274]	796	261	34.0	843	317	36.1	889	375	38.1	930	432	39.8	969	490	41.6	1007	552	43.2	1039	611	44.6	1068	668	46.0	1102	732	47.6	1135	798	48.9			
2800 [1321]	821	282	35.0	866	340	37.2	912	400	39.1	952	459	40.8	991	520	42.5	1027	583	44.1	1059	643	45.5	1088	702	46.9	1121	767	48.3	1153	834	49.7			
2900 [1368]	845	305	36.1	890	365	38.2	935	427	40.1	974	488	41.8	1012	550	43.5	1048	615	45.0	1078	676	46.4	1107	737	47.7	1139	804	49.1	1172	873	50.5			
3000 [1416]	869	330	37.1	913	391	39.2	958	456	41.1	997	518	42.8	1034	583	44.4	1069	649	46.0	1098	712	47.3	1127	774	48.6	1159	842	49.9	1190	913	51.3			
3100 [1463]	894	356	38.2	936	418	40.2	981	486	42.1	1019	550	43.8	1055	616	45.4	1090	685	46.9	1118	748	48.2	1146	812	49.5	1178	882	50.8	1209	954	52.1			
3200 [1510]	918	383	39.3	960	447	41.2	1004	517	43.1	1041	584	44.8	1077	652	46.4	1111	722	47.8	1138	787	49.1	1166	852	50.4	1197	923	51.6	1228	997	52.9			
3300 [1557]	943	412	40.3	983	478	42.2	1027	551	44.1	1064	619	45.8	1099	689	47.3	1132	761	48.8	1158	826	50.0	1186	894	51.3	1217	966	52.5	1247	1042	53.8			
3400 [1604]	967	443	41.4	1006	510	43.2	1050	585	45.1	1086	656	46.7	1121	728	48.3	1154	802	49.7	1179	868	50.9	1207	937	52.2	1237	1011	53.4	1267	1089	54.6			
3500 [1652]	992	475	42.5	1030	544	44.2	1073	622	46.1	1109	694	47.7	1143	768	49.2	1175	844	50.7	1199	911	51.9	1227	982	53.1	1257	1057	54.2	1286	1137	55.5			
3600 [1699]	1016	509	43.5	1054	579	45.3	1096	659	47.1	1132	734	48.7	1165	810	50.2	1197	888	51.6	1220	955	52.8	1248	1029	54.0	1277	1105	55.2	1306	1186	56.5			
3700 [1746]	1041	545	44.6	1077	616	46.3	1120	699	48.1	1155	776	49.7	1188	854	51.1	1219	933	52.5	1241	1001	53.7	1269	1077	54.9	1297	1155	56.1	1326	1238	57.4			
3800 [1793]	1065	582	45.7	1101	655	47.3	1143	740	49.1	1177	819	50.7	1210	899	52.1	1241	980	53.5	1262	1048	54.6	1290	1126	55.9	1318	1206	57.0	1346	1291	58.3			
3900 [1840]	1090	621	46.7	1124	695	48.3	1166	782	50.1	1200	864	51.6	1233	946	53.0	1263	1029	54.4	1283	1098	55.6	1311	1178	56.8	1339	1259	58.0	1367	1346	59.3			
4000 [1888]	1114	661	47.8	1148	736	49.4	1189	826	51.1	1223	911	52.6	1255	994	54.0	1285	1079	55.4	1305	1148	56.5	1332	1231	57.8	1359	1314	59.0	1387	1402	60.3			
4100 [1935]	1139	703	48.9	1172	779	50.4	1213	871	52.1	1247	959	53.6	1278	1045	54.9	1308	1130	56.3	1326	1200	57.4	1354	1285	58.7	1381	1371	60.0	1408	1460	61.3			

Air Flow	Model RHPDYC102 Voltage 208/230V — 3 phase 60 Hz																																
	External Static Pressure—Inches of Water [kPa]																																
	1.1 [.27]			1.2 [.30]			1.3 [.32]			1.4 [.35]			1.5 [.37]			1.6 [.40]			1.7 [.42]			1.8 [.45]			1.9 [.47]			2.0 [.50]					
	RPM	W	%	RPM	W	%	RPM	W	%	RPM	W	%	RPM	W	%	RPM	W	%	RPM	W	%	RPM	W	%	RPM	W	%	RPM	W	%	RPM	W	%
2700 [1274]	1167	867	50.5	1198	933	51.8	1227	998	53.0	1256	1068	54.3	1284	1138	55.5	1315	1211	56.7	1343	1287	57.7	1368	1361	58.1	1395	1436	59.6	1420	1509	61.1			
2800 [1321]	1185	904	51.2	1215	972	52.5	1244	1040	53.7	1273	1110	55.0	1301	1182	56.2	1332	1258	57.5	1360	1335	58.5	1385	1410	59.2	1411	1488	60.7	1436	1565	62.1			
2900 [1368]	1202	943	51.9	1233	1013	53.2	1262	1083	54.4	1290	1154	55.7	1318	1228	57.0	1349	1307	58.3	1377	1385	59.4	1401	1461	60.2	1428	1542	61.7	1453	1623	63.2			
3000 [1416]	1221	984	52.6	1251	1056	53.9	1279	1127	55.1	1307	1200	56.5	1335	1276	57.7	1367	1357	59.1	1393	1436	60.3	1418	1514	61.2	1444	1597	62.8	1470	1682	64.3			
3100 [1463]	1239	1026	53.4	1269	1101	54.7	1297	1174	55.9	1325	1248	57.3	1353	1325	58.5	1384	1410	60.0	1411	1490	61.2	1435	1569	62.3	1461	1655	63.8	1487	1743	65.3			
3200 [1510]	1257	1071	54.1	1287	1147	55.5	1315	1222	56.7	1343	1298	58.1	1370	1377	59.4	1402	1464	60.9	1428	1545	62.1	1452	1625	63.3	1478	1715	64.9	1504	1806	66.4			
3300 [1557]	1276	1117	55.0	1306	1195	56.3	1333	1272	57.6	1361	1349	58.9	1388	1430	60.2	1420	1520	61.8	1445	1603	63.1	1469	1684	64.3	1495	1776	65.9	1521	1870	67.4			
3400 [1604]	1295	1165	55.8	1324	1245	57.1	1352	1324	58.4	1379	1403	59.8	1406	1486	61.1	1438	1578	62.7	1463	1662	64.0	1487	1745	65.4	1512	1840	66.9	1538	1936	68.5			
3500 [1652]	1314	1214	56.7	1343	1296	58.0	1370	1377	59.3	1398	1458	60.7	1424	1543	62.1	1456	1638	63.6	1481	1723	65.0	1504	1807	66.4	1530	1905	68.0	1556	2004	69.5			
3600 [1699]	1334	1266	57.6	1362	1350	59.0	1389	1433	60.3	1416	1515	61.6	1442	1602	63.0	1474	1700	64.6	1499	1786	66.0	1522	1872	67.5	1547	1972	69.0	1573	2074	70.5			
3700 [1746]	1353	1319	58.5	1382	1405	59.9	1408	1490	61.2	1435	1574	62.6	1461	1663	64.0	1493	1763	65.6	1517	1851	67.0	1540	1938	68.5	1565	2041	70.0	1591	2146	71.6			
3800 [1793]	1373	1374	59.5	1401	1462	60.9	1428	1548	62.2	1454	1635	63.6	1479	1725	65.0	1511	1829	66.7	1535	1918	68.1	1558	2007	69.6	1583	2112	71.1	1609	2219	72.6			
3900 [1840]	1393	1431	60.5	1421	1521	61.9	1447	1609	63.3	1473	1698	64.6	1498	1790	66.1	1530	1896	67.7	1553	1987	69.1	1576	2077	70.6	1601	2184	72.1	1627	2294	73.6			
4000 [1888]	1413	1489	61.5	1441	1581	62.9	1467	1671	64.3	1493	1763	65.7	1517	1856	67.1	1549	1965	68.8	1572	2058	70.2	1594	2150	71.7	1619	2259	73.1	1645	2370	74.6			
4100 [1935]	1434	1550	62.6	1461	1643	64.0	1486	1735	65.4	1512	1829	66.8	1537	1925	68.2	1568	2036	69.9	1591	2131	71.3	1613	2224	72.7	1637	2335	74.2	1663	2449	75.7			

- NOTES:** 1. Factory airflow setting of VDC (%) at AHRI minimum External Static Pressure. Adjust VDC (%) value to achieve desire airflow.
 2. Do not set outside range of VDC (%) values from the values shown in Table
 3. Drive data is for Sideflow/Downflow with dry coil. Add component resistance (below) to determine total External Static Pressure

Airflow	AIRFLOW CORRECTION FACTORS*			COMPONENT AIRFLOW RESISTANCE					
				Wet Coil	Horizontal Economizer RA Damper Open	Concentric Diffuser RXRN-AEF2000 & Concentric Adapter RXMC-DD01 (Flush)	Concentric Diffuser RXRN-AED2000 & Concentric Adapter RXMC-DD01 (Drop)	Pressure Drop MERV 8	Pressure Drop MERV 13
	CFM [L/s]	Total kBtu/h	Sensible kBtu/h	Power kW	Resistance — Inches of Water [kPa]				
2400 [1133]	0.97	0.92	0.99	0.06 [.01]	0.21 [0.05]	0.66 [.16]	0.53 [.13]	0.093 [.02]	0.047 [.01]
2500 [1180]	0.97	0.93	0.99	0.06 [.01]	0.25 [0.06]	0.71 [.18]	0.57 [.14]	0.098 [.02]	0.055 [.01]
2600 [1227]	0.98	0.95	0.99	0.06 [.02]	0.28 [0.07]	0.75 [.19]	0.60 [.15]	0.103 [.02]	0.062 [.01]
2700 [1274]	0.99	0.96	0.99	0.07 [.02]	0.32 [0.08]	0.80 [.20]	0.65 [.16]	0.108 [.03]	0.070 [.02]
2800 [1321]	0.99	0.98	1.00	0.07 [.02]	0.36 [0.09]	0.85 [.21]	0.69 [.17]	0.113 [.03]	0.078 [.02]
2900 [1368]	1.00	1.00	1.00	0.08 [.02]	0.39 [0.10]	0.91 [.23]	0.74 [.18]	0.117 [.03]	0.085 [.02]
3000 [1416]	1.01	1.01	1.00	0.08 [.02]	0.43 [0.11]	0.96 [.24]	0.79 [.20]	0.122 [.03]	0.093 [.02]
3100 [1463]	1.01	1.03	1.00	0.09 [.02]	0.47 [0.12]	1.02 [.25]	0.86 [.21]	0.127 [.03]	0.100 [.02]
3200 [1510]	1.02	1.04	1.01	0.10 [.02]	0.51 [0.13]	1.08 [.27]	0.92 [.23]	0.132 [.03]	0.108 [.03]
3300 [1557]	1.02	1.06	1.01	0.10 [.03]	0.54 [0.14]	1.15 [.29]	0.99 [.25]	0.137 [.03]	0.115 [.03]
3400 [1604]	1.03	1.08	1.01	0.11 [.03]	0.58 [0.14]	1.21 [.30]	1.05 [.26]	0.142 [.03]	0.123 [.03]
3500 [1652]	1.04	1.09	1.01	0.11 [.03]	0.62 [0.15]	1.29 [.32]	1.09 [.27]	0.147 [.04]	0.131 [.03]
3600 [1699]	1.04	1.11	1.02	0.12 [.03]	0.66 [0.16]	1.36 [.34]	1.13 [.28]	0.152 [.04]	0.138 [.03]

*Multiply correction factor times gross performance data resulting sensible capacity cannot exceed total capacity

[] Designates Metric Conversions

AIRFLOW PERFORMANCE— 8.5 TON — 60 Hz — 208/230V — SIDEFLOW

Air Flow	Model RHPDYC0102 Voltage 208/230V — 3 phase 60 Hz																																
	External Static Pressure—Inches of Water [kPa]																																
	0.1 [.02]			0.2 [.05]			0.3 [.07]			0.4 [.10]			0.5 [.12]			0.6 [.15]			0.7 [.17]			0.8 [.20]			0.9 [.22]			1.0 [.25]					
	RPM	W	%	RPM	W	%	RPM	W	%	RPM	W	%	RPM	W	%	RPM	W	%	RPM	W	%	RPM	W	%	RPM	W	%	RPM	W	%	RPM	W	%
2700 [1274]	781	248	33.5	823	296	35.4	861	343	36.9	901	397	38.7	933	443	40.1	974	502	41.9	1008	557	43.3	1044	614	44.8	1076	673	46.2	1102	725	47.5			
2800 [1321]	806	268	34.5	846	317	36.3	883	366	37.9	923	422	39.7	953	469	41.0	994	530	42.8	1028	586	44.2	1062	645	45.7	1094	705	47.0	1119	756	48.2			
2900 [1368]	830	289	35.5	868	340	37.3	905	391	38.8	944	448	40.6	974	496	42.0	1014	560	43.7	1047	617	45.1	1080	677	46.5	1112	738	47.8	1136	790	49.0			
3000 [1416]	854	312	36.6	891	364	38.3	928	417	39.8	966	476	41.5	995	525	42.9	1034	591	44.6	1067	649	45.9	1099	711	47.3	1130	773	48.7	1153	825	49.7			
3100 [1463]	878	337	37.6	914	390	39.3	950	445	40.8	988	505	42.5	1016	556	43.8	1054	623	45.5	1086	684	46.8	1118	747	48.2	1148	810	49.5	1171	862	50.5			
3200 [1510]	902	363	38.6	938	417	40.2	973	474	41.8	1010	536	43.5	1037	588	44.7	1075	657	46.4	1106	719	47.7	1138	784	49.0	1167	848	50.3	1189	900	51.2			
3300 [1557]	927	390	39.6	961	446	41.2	996	505	42.8	1032	569	44.4	1058	622	45.7	1096	693	47.3	1127	757	48.6	1157	822	49.9	1186	888	51.2	1207	941	52.0			
3400 [1604]	951	420	40.7	984	477	42.2	1019	538	43.8	1054	603	45.4	1080	658	46.6	1117	730	48.2	1147	796	49.5	1177	863	50.8	1205	930	52.0	1225	983	52.9			
3500 [1652]	975	450	41.7	1008	509	43.2	1042	572	44.8	1076	638	46.3	1101	695	47.5	1138	769	49.2	1167	836	50.4	1197	905	51.6	1225	973	52.9	1244	1027	53.7			
3600 [1699]	1000	483	42.8	1031	542	44.3	1066	608	45.8	1099	675	47.3	1123	733	48.5	1159	810	50.1	1188	878	51.3	1217	948	52.5	1244	1018	53.8	1263	1073	54.6			
3700 [1746]	1024	517	43.8	1055	577	45.3	1089	646	46.8	1121	714	48.3	1145	774	49.4	1180	852	51.0	1209	922	52.2	1237	993	53.4	1264	1065	54.7	1283	1121	55.4			
3800 [1793]	1049	552	44.9	1078	614	46.3	1113	685	47.8	1143	754	49.2	1167	815	50.4	1202	895	51.9	1230	967	53.1	1258	1040	54.3	1285	1113	55.6	1302	1171	56.3			
3900 [1840]	1073	589	46.0	1102	652	47.3	1136	726	48.9	1166	795	50.2	1189	859	51.3	1224	940	52.8	1252	1014	54.0	1279	1088	55.2	1305	1163	56.5	1322	1222	57.3			
4000 [1888]	1098	628	47.0	1126	692	48.4	1160	768	49.9	1189	838	51.2	1211	904	52.3	1246	987	53.7	1273	1062	55.0	1300	1138	56.1	1326	1214	57.4	1343	1275	58.2			
4100 [1935]	1122	668	48.1	1150	733	49.4	1184	812	50.9	1211	883	52.2	1233	950	53.2	1268	1035	54.6	1295	1113	55.9	1321	1190	57.1	1347	1267	58.3	1363	1330	59.1			

Air Flow	Model RHPDYC102 Voltage 208/230V — 3 phase 60 Hz																																
	External Static Pressure—Inches of Water [kPa]																																
	1.1 [.27]			1.2 [.30]			1.3 [.32]			1.4 [.35]			1.5 [.37]			1.6 [.40]			1.7 [.42]			1.8 [.45]			1.9 [.47]			2.0 [.50]					
	RPM	W	%	RPM	W	%	RPM	W	%	RPM	W	%	RPM	W	%	RPM	W	%	RPM	W	%	RPM	W	%	RPM	W	%	RPM	W	%	RPM	W	%
2700 [1274]	1139	796	49.1	1169	860	50.5	1200	927	51.7	1228	993	53.1	1248	1050	54.1	1281	1122	55.2	1307	1189	56.3	1332	1258	57.3	1356	1325	58.2	1372	1378	59.0			
2800 [1321]	1156	829	49.8	1185	894	51.1	1217	962	52.3	1244	1029	53.6	1263	1087	54.6	1297	1162	55.8	1323	1231	57.0	1348	1302	58.1	1372	1372	59.1	1388	1429	59.9			
2900 [1368]	1173	865	50.5	1202	929	51.8	1233	999	53.0	1260	1068	54.2	1279	1126	55.2	1313	1203	56.5	1339	1275	57.7	1364	1348	58.8	1388	1421	60.0	1404	1482	60.8			
3000 [1416]	1190	902	51.2	1218	967	52.4	1249	1038	53.7	1277	1108	54.9	1295	1168	55.9	1329	1247	57.2	1355	1320	58.4	1380	1396	59.6	1404	1472	60.8	1421	1536	61.8			
3100 [1463]	1208	941	52.0	1236	1006	53.1	1266	1079	54.4	1293	1151	55.6	1312	1211	56.5	1346	1293	57.9	1371	1368	59.2	1397	1446	60.5	1421	1524	61.7	1437	1591	62.7			
3200 [1510]	1226	981	52.8	1253	1048	53.9	1283	1122	55.1	1310	1195	56.3	1328	1256	57.2	1362	1341	58.7	1388	1417	60.0	1413	1498	61.3	1438	1578	62.6	1454	1648	63.6			
3300 [1557]	1244	1024	53.6	1271	1091	54.7	1301	1167	55.9	1328	1241	57.0	1345	1303	58.0	1379	1390	59.5	1404	1468	60.8	1430	1551	62.2	1454	1634	63.5	1470	1706	64.5			
3400 [1604]	1262	1068	54.4	1289	1137	55.5	1318	1214	56.7	1345	1290	57.8	1362	1352	58.8	1396	1442	60.3	1421	1521	61.7	1446	1606	63.1	1471	1692	64.5	1487	1765	65.5			
3500 [1652]	1281	1114	55.2	1307	1184	56.3	1336	1262	57.5	1363	1340	58.7	1379	1403	59.6	1413	1495	61.2	1438	1577	62.6	1463	1663	64.0	1488	1751	65.4	1503	1825	66.4			
3600 [1699]	1299	1162	56.1	1326	1234	57.2	1354	1313	58.4	1380	1392	59.5	1396	1455	60.4	1431	1551	62.1	1455	1633	63.5	1480	1722	64.9	1505	1812	66.3	1520	1887	67.4			
3700 [1746]	1318	1211	57.0	1344	1285	58.1	1373	1366	59.3	1398	1446	60.4	1414	1510	61.3	1448	1608	63.0	1473	1692	64.4	1497	1782	65.9	1522	1874	67.3	1537	1950	68.3			
3800 [1793]	1338	1262	57.9	1364	1339	59.0	1391	1420	60.2	1417	1501	61.4	1432	1567	62.3	1466	1667	64.0	1490	1753	65.4	1515	1845	66.8	1539	1938	68.3	1554	2015	69.3			
3900 [1840]	1357	1316	58.8	1383	1394	59.9	1410	1477	61.2	1435	1559	62.3	1450	1625	63.2	1484	1729	65.0	1508	1816	66.4	1532	1909	67.8	1556	2004	69.3	1570	2081	70.3			
4000 [1888]	1377	1371	59.8	1403	1451	60.9	1429	1536	62.2	1454	1619	63.4	1468	1686	64.2	1502	1792	66.0	1525	1880	67.4	1550	1975	68.8	1574	2072	70.3	1587	2148	71.3			
4100 [1935]	1397	1427	60.7	1423	1511	62.0	1449	1596	63.2	1473	1680	64.4	1486	1748	65.3	1520	1857	67.1	1543	1947	68.5	1567	2043	69.9	1591	2141	71.3	1604	2216	72.3			

- NOTES:** 1. Factory airflow setting of VDC (%) at AHRI minimum External Static Pressure. Adjust VDC (%) value to achieve desire airflow.
2. Do not set outside range of VDC (%) values from the values shown in Table
3. Drive data is for Sideflow/Downflow with dry coil. Add component resistance (below) to determine total External Static Pressure

AIRFLOW PERFORMANCE — 8.5 TON — 60 Hz — 208/230V — SIDEFLOW (CONTINUED)

Airflow	AIRFLOW CORRECTION FACTORS*			COMPONENT AIRFLOW RESISTANCE					
				Wet Coil	Horizontal Economizer RA Damper Open	Concentric Diffuser RXRN-AEF2000 & Concentric Adapter RXMC-DD01 (Flush)	Concentric Diffuser RXRN-AED2000 & Concentric Adapter RXMC-DD01 (Drop)	Pressure Drop MERV 8	Pressure Drop MERV 13
CFM [L/s]	Total kBtu/h	Sensible kBtu/h	Power kW	Resistance — Inches of Water [kPa]					
2700 [1274]	0.99	0.96	0.99	0.07 [.02]	0.32 [0.08]	0.80 [.20]	0.65 [.16]	0.108 [.03]	0.070 [.02]
2800 [1321]	0.99	0.98	1.00	0.07 [.02]	0.36 [0.09]	0.85 [.21]	0.69 [.17]	0.113 [.03]	0.078 [.02]
2900 [1368]	1.00	1.00	1.00	0.08 [.02]	0.39 [0.10]	0.91 [.23]	0.74 [.18]	0.117 [.03]	0.085 [.02]
3000 [1416]	1.01	1.01	1.00	0.08 [.02]	0.43 [0.11]	0.96 [.24]	0.79 [.20]	0.122 [.03]	0.093 [.02]
3100 [1463]	1.01	1.03	1.00	0.09 [.02]	0.47 [0.12]	1.02 [.25]	0.86 [.21]	0.127 [.03]	0.100 [.02]
3200 [1510]	1.02	1.04	1.01	0.10 [.02]	0.51 [0.13]	1.08 [.27]	0.92 [.23]	0.132 [.03]	0.108 [.03]
3300 [1557]	1.02	1.06	1.01	0.10 [.03]	0.54 [0.14]	1.15 [.29]	0.99 [.25]	0.137 [.03]	0.115 [.03]
3400 [1604]	1.03	1.08	1.01	0.11 [.03]	0.58 [0.14]	1.21 [.30]	1.05 [.26]	0.142 [.03]	0.123 [.03]
3500 [1652]	1.04	1.09	1.01	0.11 [.03]	0.62 [0.15]	1.29 [.32]	1.09 [.27]	0.147 [.04]	0.131 [.03]
3600 [1699]	1.04	1.11	1.02	0.12 [.03]	0.66 [0.16]	1.36 [.34]	1.13 [.28]	0.152 [.04]	0.138 [.03]
3700 [1746]	1.05	1.12	1.02	0.13 [.03]	0.70 [0.17]	1.43 [.36]	1.18 [.29]	0.157 [.04]	0.146 [.04]
3800 [1793]	1.05	1.14	1.02	0.13 [.03]	0.74 [0.18]	1.50 [.37]	1.23 [.31]	0.162 [.04]	0.153 [.04]
3900 [1840]	1.06	1.16	1.02	0.14 [.04]	0.77 [0.19]	1.59 [.40]	1.31 [.33]	0.167 [.04]	0.161 [.04]
4000 [1888]	1.07	1.17	1.02	0.15 [.04]	0.81 [0.20]	1.68 [.42]	1.38 [.34]	0.171 [.04]	0.169 [.04]
4100 [1935]	1.07	1.19	1.03	0.15 [.04]	0.85 [0.21]	1.74 [.43]	1.44 [.36]	0.176 [.04]	0.176 [.04]

*Multiply correction factor times gross performance data resulting sensible capacity cannot exceed total capacity.

[] Designates Metric Conversions

AIRFLOW PERFORMANCE— 8.5 TON — 60 Hz — 460V — DOWNFLOW

Air Flow	Model RHPDYC0102 Voltage 460V — 3 phase 60 Hz																													
	External Static Pressure—Inches of Water [kPa]																													
	0.1 [.02]			0.2 [.05]			0.3 [.07]			0.4 [.10]			0.5 [.12]			0.6 [.15]			0.7 [.17]			0.8 [.20]			0.9 [.22]			1.0 [.25]		
	RPM	W	%	RPM	W	%	RPM	W	%	RPM	W	%	RPM	W	%	RPM	W	%	RPM	W	%	RPM	W	%	RPM	W	%	RPM	W	%
2700 [1274]	809	307	31.0	849	358	32.5	891	414	34.4	923	462	35.8	959	516	37.3	995	570	38.7	1030	628	40.0	1062	685	40.0	1089	736	42.4	1116	794	43.6
2800 [1321]	834	329	32.0	873	385	33.5	914	440	35.3	943	487	36.6	980	546	38.1	1014	600	39.5	1050	661	40.8	1082	719	40.8	1109	775	43.3	1134	828	44.3
2900 [1368]	859	354	33.0	895	408	34.5	937	468	36.2	967	519	37.6	1000	573	38.9	1036	635	40.4	1069	694	41.6	1100	752	41.6	1128	812	44.1	1155	872	45.2
3000 [1416]	881	378	33.9	918	434	35.4	960	497	37.1	989	548	38.4	1022	607	39.8	1057	669	41.2	1083	721	42.2	1120	790	42.2	1147	851	44.9	1172	906	45.9
3100 [1463]	903	402	34.8	946	468	36.5	982	527	38.0	1011	580	39.3	1045	641	40.7	1077	702	42.0	1104	759	43.1	1141	832	43.1	1168	893	45.8	1191	947	46.8
3200 [1510]	929	432	35.8	965	493	37.3	1005	558	38.9	1033	613	40.2	1066	675	41.5	1100	742	42.9	1126	802	44.0	1160	868	44.0	1187	933	46.6	1210	989	47.6
3300 [1557]	952	459	36.7	988	522	38.2	1028	592	39.8	1063	657	41.3	1088	711	42.4	1121	779	43.8	1145	836	44.8	1182	913	44.8	1206	975	47.4	1229	1033	48.4
3400 [1604]	979	494	37.8	1013	557	39.2	1051	625	40.7	1085	691	42.1	1112	752	43.4	1143	819	44.7	1168	881	45.8	1203	959	45.8	1230	1028	48.4	1251	1084	49.3
3500 [1652]	1004	528	38.8	1037	590	40.1	1073	660	41.6	1108	729	43.0	1131	788	44.2	1164	860	45.6	1189	923	46.7	1222	1000	46.7	1250	1073	49.2	1272	1133	50.1
3600 [1699]	1028	559	39.7	1060	625	41.0	1096	697	42.5	1132	772	44.0	1155	831	45.2	1186	901	46.5	1210	967	47.6	1237	1037	47.6	1271	1122	50.0	1293	1183	50.9
3700 [1746]	1051	592	40.6	1085	664	42.0	1120	737	43.5	1156	815	45.0	1178	870	46.1	1209	950	47.5	1235	1019	48.6	1256	1080	48.6	1290	1168	50.8	1313	1237	51.7
3800 [1793]	1076	631	41.6	1106	697	42.8	1143	778	44.5	1178	855	45.9	1201	918	47.1	1236	1004	48.6	1255	1062	49.4	1276	1127	49.4	1313	1225	51.7	1335	1289	52.4
3900 [1840]	1103	671	42.6	1132	742	43.9	1167	820	45.5	1203	903	47.0	1225	968	48.1	1260	1057	49.5	1279	1115	50.3	1299	1182	50.3	1333	1274	52.4	1354	1340	53.1
4000 [1888]	1125	708	43.5	1158	787	45.0	1191	866	46.5	1224	946	47.9	1255	1024	49.2	1283	1107	50.4	1300	1164	51.1	1321	1233	51.1	1353	1328	53.1	1376	1399	53.8
4100 [1935]	1148	748	44.5	1184	836	46.1	1213	907	47.4	1247	991	48.8	1278	1075	50.1	1304	1160	51.2	1323	1220	52.0	1344	1292	52.0	1375	1384	53.8	1398	1462	54.5

Air Flow	Model RHPDYC102 Voltage 460V — 3 phase 60 Hz																													
	External Static Pressure—Inches of Water [kPa]																													
	1.1 [.27]			1.2 [.30]			1.3 [.32]			1.4 [.35]			1.5 [.37]			1.6 [.40]			1.7 [.42]			1.8 [.45]			1.9 [.47]			2.0 [.50]		
	RPM	W	%	RPM	W	%	RPM	W	%	RPM	W	%	RPM	W	%	RPM	W	%	RPM	W	%	RPM	W	%	RPM	W	%	RPM	W	%
2700 [1274]	1148	855	44.9	1179	921	46.3	1215	990	47.7	1246	1062	49.0	1275	1123	50.1	1294	1178	50.9	1321	1247	51.9	1341	1300	52.6	1360	1358	53.3	1382	1416	53.9
2800 [1321]	1166	894	45.7	1195	955	47.0	1234	1034	48.5	1263	1103	49.7	1293	1169	50.8	1312	1227	51.6	1338	1298	52.5	1355	1347	53.1	1376	1406	53.8	1401	1478	54.5
2900 [1368]	1185	933	46.5	1214	998	47.8	1251	1076	49.2	1284	1152	50.5	1313	1222	51.6	1330	1276	52.2	1359	1358	53.2	1375	1409	53.7	1395	1470	54.4	1418	1535	55.1
3000 [1416]	1203	975	47.3	1233	1041	48.6	1268	1118	49.9	1303	1203	51.3	1330	1269	52.2	1346	1323	52.8	1375	1405	53.7	1392	1458	54.2	1414	1528	55.0	1435	1592	55.7
3100 [1463]	1222	1018	48.1	1251	1084	49.3	1289	1170	50.7	1320	1245	51.9	1348	1317	52.8	1365	1376	53.4	1392	1454	54.2	1407	1510	54.8	1430	1581	55.6	1450	1648	56.4
3200 [1510]	1241	1062	48.9	1270	1132	50.1	1302	1209	51.3	1341	1300	52.6	1368	1372	53.4	1380	1421	53.9	1410	1509	54.8	1424	1562	55.3	1447	1637	56.3	1469	1712	57.3
3300 [1557]	1261	1109	49.7	1291	1184	50.9	1319	1257	52.0	1361	1357	53.3	1388	1432	54.1	1396	1474	54.4	1424	1558	55.3	1443	1625	56.1	1464	1700	57.1	1487	1776	58.3
3400 [1604]	1281	1158	50.5	1308	1228	51.6	1337	1302	52.6	1380	1411	53.9	1404	1478	54.6	1416	1532	55.1	1439	1609	56.0	1460	1678	56.8	1481	1758	58.0	1506	1843	59.4
3500 [1652]	1301	1209	51.3	1329	1281	52.3	1357	1360	53.3	1400	1468	54.5	1422	1533	55.2	1437	1593	55.8	1459	1670	56.8	1477	1738	57.7	1502	1826	59.2	1525	1909	60.5
3600 [1699]	1321	1257	52.0	1353	1343	53.1	1377	1413	53.9	1418	1519	55.1	1442	1597	56.0	1457	1660	56.7	1479	1735	57.8	1498	1809	58.9	1521	1893	60.3	1543	1976	61.6
3700 [1746]	1343	1317	52.8	1372	1397	53.7	1398	1470	54.5	1438	1578	55.8	1461	1657	56.8	1474	1714	57.5	1498	1799	58.9	1516	1870	59.9	1538	1959	61.3	1561	2003	62.5
3800 [1793]	1365	1374	53.5	1393	1456	54.4	1419	1532	55.2	1456	1637	56.6	1480	1720	57.8	1495	1785	58.7	1519	1872	60.1	1532	1935	60.9	1556	1978	62.2	1581	2073	63.4
3900 [1840]	1388	1436	54.2	1413	1511	55.0	1440	1598	56.0	1471	1690	57.4	1499	1785	58.9	1511	1846	59.7	1537	1937	61.2	1552	2007	62.1	1574	2048	63.1	1598	2137	64.2
4000 [1888]	1413	1508	55.0	1431	1566	55.7	1460	1659	56.9	1491	1755	58.5	1519	1851	60.0	1536	1928	61.1	1557	1968	62.2	1570	2036	62.9	1588	2109	63.8	1619	2217	65.1
4100 [1935]	1431	1557	55.6	1458	1645	56.8	1482	1727	58.0	1511	1824	59.7	1540	1927	61.3	1558	1965	62.2	1576	2036	63.1	1590	2107	63.8	1612	2191	64.8	1636	2291	65.9

NOTES: 1. Factory airflow setting of VDC (%) at AHRI minimum External Static Pressure. Adjust VDC (%) value to achieve desire airflow.
 2. Do not set outside range of VDC (%) values from the values shown in Table
 3. Drive data is for Sideflow/Downflow with dry coil. Add component resistance (below) to determine total External Static Pressure

Airflow	AIRFLOW CORRECTION FACTORS*						COMPONENT AIRFLOW RESISTANCE					
							Wet Coil	Horizontal Economizer RA Damper Open	Concentric Diffuser RXRN-AEF2000 & Concentric Adapter RXMC-DD01 (Flush)	Concentric Diffuser RXRN-AED2000 & Concentric Adapter RXMC-DD01 (Drop)	Pressure Drop MERV 8	Pressure Drop MERV 13
	CFM [L/s]	Total kBtu/h	Sensible kBtu/h	Power kW	Resistance — Inches of Water [kPa]							
2400 [1133]	0.97	0.92	0.99	0.06 [.01]	0.21 [0.05]	0.66 [.16]	0.53 [.13]	0.093 [.02]	0.047 [.01]			
2500 [1180]	0.97	0.93	0.99	0.06 [.01]	0.25 [0.06]	0.71 [.18]	0.57 [.14]	0.098 [.02]	0.055 [.01]			
2600 [1227]	0.98	0.95	0.99	0.06 [.02]	0.28 [0.07]	0.75 [.19]	0.60 [.15]	0.103 [.02]	0.062 [.01]			
2700 [1274]	0.99	0.96	0.99	0.07 [.02]	0.32 [0.08]	0.80 [.20]	0.65 [.16]	0.108 [.03]	0.070 [.02]			
2800 [1321]	0.99	0.98	1.00	0.07 [.02]	0.36 [0.09]	0.85 [.21]	0.69 [.17]	0.113 [.03]	0.078 [.02]			
2900 [1368]	1.00	1.00	1.00	0.08 [.02]	0.39 [0.10]	0.91 [.23]	0.74 [.18]	0.117 [.03]	0.085 [.02]			
3000 [1416]	1.01	1.01	1.00	0.08 [.02]	0.43 [0.11]	0.96 [.24]	0.79 [.20]	0.122 [.03]	0.093 [.02]			
3100 [1463]	1.01	1.03	1.00	0.09 [.02]	0.47 [0.12]	1.02 [.25]	0.86 [.21]	0.127 [.03]	0.100 [.02]			
3200 [1510]	1.02	1.04	1.01	0.10 [.02]	0.51 [0.13]	1.08 [.27]	0.92 [.23]	0.132 [.03]	0.108 [.03]			
3300 [1557]	1.02	1.06	1.01	0.10 [.03]	0.54 [0.14]	1.15 [.29]	0.99 [.25]	0.137 [.03]	0.115 [.03]			
3400 [1604]	1.03	1.08	1.01	0.11 [.03]	0.58 [0.14]	1.21 [.30]	1.05 [.26]	0.142 [.03]	0.123 [.03]			
3500 [1652]	1.04	1.09	1.01	0.11 [.03]	0.62 [0.15]	1.29 [.32]	1.09 [.27]	0.147 [.04]	0.131 [.03]			
3600 [1699]	1.04	1.11	1.02	0.12 [.03]	0.66 [0.16]	1.36 [.34]	1.13 [.28]	0.152 [.04]	0.138 [.03]			

*Multiply correction factor times gross performance data resulting sensible capacity cannot exceed total capacity

[] Designates Metric Conversions

AIRFLOW PERFORMANCE — 8.5 TON — 60 Hz — 460V — SIDEFLOW

Air Flow	Model RHPDYC0102 Voltage 460V — 3 phase 60 Hz																																
	External Static Pressure—Inches of Water [kPa]																																
	0.1 [.02]			0.2 [.05]			0.3 [.07]			0.4 [.10]			0.5 [.12]			0.6 [.15]			0.7 [.17]			0.8 [.20]			0.9 [.22]			1.0 [.25]					
	RPM	W	%	RPM	W	%	RPM	W	%	RPM	W	%	RPM	W	%	RPM	W	%	RPM	W	%	RPM	W	%	RPM	W	%	RPM	W	%	RPM	W	%
2700 [1274]	790	286	30.2	841	344	32.4	875	390	33.8	916	447	35.4	952	498	36.8	981	547	38.1	1009	594	39.3	1046	654	40.7	1071	701	41.7	1109	768	43.2			
2800 [1321]	814	307	31.2	863	365	33.3	898	416	34.7	937	472	36.2	973	528	37.7	1002	577	38.9	1034	630	40.2	1064	684	41.4	1090	737	42.5	1129	805	44.0			
2900 [1368]	845	335	32.4	886	389	34.2	922	443	35.6	956	497	37.0	993	554	38.5	1022	608	39.7	1055	664	41.0	1085	720	42.2	1108	771	43.3	1147	841	44.8			
3000 [1416]	868	358	33.3	909	414	35.1	944	470	36.5	977	524	37.8	1014	585	39.3	1042	638	40.5	1073	694	41.7	1104	755	43.0	1125	804	44.0	1166	880	45.6			
3100 [1463]	890	380	34.2	941	450	36.3	966	498	37.4	1000	555	38.7	1038	618	40.2	1062	671	41.3	1094	729	42.5	1124	790	43.8	1144	839	44.8	1185	920	46.4			
3200 [1510]	917	411	35.3	963	475	37.1	989	528	38.3	1021	584	39.5	1060	654	41.1	1083	704	42.1	1115	766	43.4	1145	831	44.7	1165	881	45.7	1204	962	47.2			
3300 [1557]	943	440	36.3	985	504	38.0	1011	558	39.2	1047	622	40.5	1081	686	41.9	1101	735	42.8	1135	802	44.2	1160	863	45.4	1184	920	46.5	1223	1003	48.0			
3400 [1604]	968	471	37.3	1007	535	38.9	1034	590	40.1	1066	653	41.3	1106	726	42.9	1124	776	43.8	1155	841	45.1	1182	904	46.3	1202	958	47.3	1240	1041	48.7			
3500 [1652]	986	492	38.0	1034	569	39.9	1062	629	41.1	1090	690	42.2	1131	767	43.9	1143	809	44.6	1177	882	46.0	1208	954	47.3	1224	1005	48.2	1260	1087	49.5			
3600 [1699]	1014	529	39.1	1059	605	40.9	1085	664	42.0	1115	730	43.2	1152	804	44.8	1165	851	45.5	1195	921	46.8	1228	996	48.2	1245	1050	49.0	1277	1129	50.2			
3700 [1746]	1042	569	40.2	1082	639	41.8	1107	699	42.9	1135	764	44.0	1175	846	45.8	1179	882	46.2	1218	964	47.7	1249	1040	49.0	1267	1099	49.9	1293	1169	50.9			
3800 [1793]	1066	602	41.1	1105	674	42.7	1131	739	43.9	1158	805	45.0	1196	887	46.7	1203	926	47.2	1242	1015	48.7	1268	1084	49.8	1287	1147	50.7	1312	1218	51.7			
3900 [1840]	1094	644	42.2	1129	712	43.7	1158	784	45.0	1181	848	46.0	1218	930	47.6	1223	969	48.0	1265	1065	49.6	1286	1128	50.5	1309	1196	51.5	1333	1269	52.4			
4000 [1888]	1117	679	43.1	1156	760	44.8	1176	819	45.8	1205	894	47.0	1239	975	48.5	1248	1021	49.0	1284	1105	50.3	1309	1179	51.4	1328	1242	52.2	1353	1320	53.1			
4100 [1935]	1144	724	44.2	1182	809	45.9	1203	870	46.9	1229	939	48.0	1261	1019	49.3	1269	1065	49.9	1305	1153	51.1	1330	1229	52.1	1351	1300	53.0	1373	1372	53.7			

Air Flow	Model RHPDYC102 Voltage 460V — 3 phase 60 Hz																																
	External Static Pressure—Inches of Water [kPa]																																
	1.1 [.27]			1.2 [.30]			1.3 [.32]			1.4 [.35]			1.5 [.37]			1.6 [.40]			1.7 [.42]			1.8 [.45]			1.9 [.47]			2.0 [.50]					
	RPM	W	%	RPM	W	%	RPM	W	%	RPM	W	%	RPM	W	%	RPM	W	%	RPM	W	%	RPM	W	%	RPM	W	%	RPM	W	%	RPM	W	%
2700 [1274]	1134	820	44.4	1161	877	45.5	1190	938	46.6	1217	1001	47.8	1243	1059	48.9	1264	1107	49.8	1294	1173	50.9	1309	1216	51.6	1339	1285	52.6	1368	1371	53.5			
2800 [1321]	1157	864	45.3	1177	914	46.2	1206	975	47.3	1233	1039	48.5	1260	1102	49.6	1282	1156	50.5	1311	1227	51.6	1329	1273	52.3	1357	1338	53.2	1384	1420	54.0			
2900 [1368]	1177	905	46.1	1195	953	47.0	1224	1018	48.1	1248	1076	49.1	1278	1148	50.3	1299	1204	51.2	1330	1283	52.3	1347	1330	52.9	1372	1392	53.7	1403	1483	54.6			
3000 [1416]	1193	940	46.8	1213	990	47.7	1241	1057	48.8	1268	1123	49.9	1294	1191	51.0	1315	1247	51.8	1346	1325	52.8	1366	1382	53.4	1389	1451	54.3	1414	1526	55.0			
3100 [1463]	1213	982	47.6	1231	1035	48.5	1258	1098	49.5	1286	1169	50.6	1310	1232	51.6	1335	1302	52.5	1361	1369	53.3	1383	1435	54.0	1408	1508	54.9	1429	1579	55.6			
3200 [1510]	1231	1026	48.4	1249	1076	49.2	1275	1142	50.2	1303	1212	51.3	1330	1284	52.3	1349	1341	53.0	1379	1423	53.9	1399	1483	54.5	1426	1566	55.5	1444	1636	56.3			
3300 [1557]	1252	1072	49.2	1265	1115	49.9	1293	1187	50.9	1322	1262	52.0	1347	1330	52.9	1367	1395	53.6	1399	1482	54.5	1419	1547	55.2	1442	1630	56.2	1462	1697	57.1			
3400 [1604]	1268	1113	49.9	1287	1167	50.7	1311	1233	51.6	1339	1308	52.6	1366	1384	53.5	1387	1450	54.2	1414	1527	55.0	1434	1593	55.7	1460	1689	57.0	1481	1764	58.1			
3500 [1652]	1289	1163	50.7	1305	1213	51.4	1330	1286	52.3	1358	1358	53.2	1383	1430	54.0	1405	1501	54.8	1431	1580	55.6	1453	1653	56.5	1482	1754	58.1	1499	1823	59.1			
3600 [1699]	1307	1208	51.4	1324	1264	52.1	1348	1333	52.9	1377	1413	53.8	1402	1486	54.6	1423	1553	55.3	1448	1633	56.3	1469	1708	57.3	1499	1815	59.1	1512	1875	59.9			
3700 [1746]	1327	1258	52.1	1344	1316	52.8	1367	1386	53.5	1393	1462	54.3	1420	1540	55.2	1441	1610	56.0	1464	1690	57.1	1486	1767	58.2	1521	1885	60.3	1529	1936	60.9			
3800 [1793]	1347	1308	52.8	1363	1367	53.4	1386	1439	54.1	1415	1525	55.0	1436	1592	55.8	1460	1671	56.9	1478	1742	57.9	1503	1824	59.2	1539	1948	61.3	1551	2007	62.1			
3900 [1840]	1369	1365	53.5	1385	1424	54.1	1405	1493	54.7	1434	1582	55.7	1456	1653	56.6	1478	1729	57.8	1494	1802	58.8	1522	1891	60.3	1557	1969	62.2	1567	2028	62.8			
4000 [1888]	1388	1414	54.1	1404	1479	54.7	1426	1554	55.4	1450	1634	56.4	1478	1722	57.7	1497	1797	58.9	1510	1854	59.7	1542	1965	61.5	1573	2034	63.0	1583	2091	63.6			
4100 [1935]	1409	1473	54.8	1424	1532	55.3	1446	1613	56.2	1469	1693	57.3	1496	1781	58.7	1514	1857	59.9	1528	1920	60.8	1561	1987	62.4	1590	2097	63.8	1603	2164	64.5			

- NOTES:** 1. Factory airflow setting of VDC (%) at AHRI minimum External Static Pressure. Adjust VDC (%) value to achieve desire airflow.
2. Do not set outside range of VDC (%) values from the values shown in Table
3. Drive data is for Sideflow/Downflow with dry coil. Add component resistance (below) to determine total External Static Pressure

AIRFLOW PERFORMANCE — 8.5 TON — 60 Hz — 460V — SIDEFLOW (CONTINUED)

Airflow	AIRFLOW CORRECTION FACTORS*			COMPONENT AIRFLOW RESISTANCE					
				Wet Coil	Horizontal Economizer RA Damper Open	Concentric Diffuser RXRN-AEF2000 & Concentric Adapter RXMC-DD01 (Flush)	Concentric Diffuser RXRN-AED2000 & Concentric Adapter RXMC-DD01 (Drop)	Pressure Drop MERV 8	Pressure Drop MERV 13
CFM [L/s]	Total kBtu/h	Sensible kBtu/h	Power kW	Resistance — Inches of Water [kPa]					
2700 [1274]	0.99	0.96	0.99	0.07 [.02]	0.32 [0.08]	0.80 [.20]	0.65 [.16]	0.108 [.03]	0.070 [.02]
2800 [1321]	0.99	0.98	1.00	0.07 [.02]	0.36 [0.09]	0.85 [.21]	0.69 [.17]	0.113 [.03]	0.078 [.02]
2900 [1368]	1.00	1.00	1.00	0.08 [.02]	0.39 [0.10]	0.91 [.23]	0.74 [.18]	0.117 [.03]	0.085 [.02]
3000 [1416]	1.01	1.01	1.00	0.08 [.02]	0.43 [0.11]	0.96 [.24]	0.79 [.20]	0.122 [.03]	0.093 [.02]
3100 [1463]	1.01	1.03	1.00	0.09 [.02]	0.47 [0.12]	1.02 [.25]	0.86 [.21]	0.127 [.03]	0.100 [.02]
3200 [1510]	1.02	1.04	1.01	0.10 [.02]	0.51 [0.13]	1.08 [.27]	0.92 [.23]	0.132 [.03]	0.108 [.03]
3300 [1557]	1.02	1.06	1.01	0.10 [.03]	0.54 [0.14]	1.15 [.29]	0.99 [.25]	0.137 [.03]	0.115 [.03]
3400 [1604]	1.03	1.08	1.01	0.11 [.03]	0.58 [0.14]	1.21 [.30]	1.05 [.26]	0.142 [.03]	0.123 [.03]
3500 [1652]	1.04	1.09	1.01	0.11 [.03]	0.62 [0.15]	1.29 [.32]	1.09 [.27]	0.147 [.04]	0.131 [.03]
3600 [1699]	1.04	1.11	1.02	0.12 [.03]	0.66 [0.16]	1.36 [.34]	1.13 [.28]	0.152 [.04]	0.138 [.03]
3700 [1746]	1.05	1.12	1.02	0.13 [.03]	0.70 [0.17]	1.43 [.36]	1.18 [.29]	0.157 [.04]	0.146 [.04]
3800 [1793]	1.05	1.14	1.02	0.13 [.03]	0.74 [0.18]	1.50 [.37]	1.23 [.31]	0.162 [.04]	0.153 [.04]
3900 [1840]	1.06	1.16	1.02	0.14 [.04]	0.77 [0.19]	1.59 [.40]	1.31 [.33]	0.167 [.04]	0.161 [.04]
4000 [1888]	1.07	1.17	1.02	0.15 [.04]	0.81 [0.20]	1.68 [.42]	1.38 [.34]	0.171 [.04]	0.169 [.04]
4100 [1935]	1.07	1.19	1.03	0.15 [.04]	0.85 [0.21]	1.74 [.43]	1.44 [.36]	0.176 [.04]	0.176 [.04]

*Multiply correction factor times gross performance data resulting sensible capacity cannot exceed total capacity.

[] Designates Metric Conversions

AIRFLOW PERFORMANCE — 10 TON — 60 Hz — 208/230V — DOWNFLOW

Air Flow	Model RHPDYC0120 Voltage 208/230 — 3 phase 60 Hz																																
	External Static Pressure—Inches of Water [kPa]																																
	0.1 [.02]			0.2 [.05]			0.3 [.07]			0.4 [.10]			0.5 [.12]			0.6 [.15]			0.7 [.17]			0.8 [.20]			0.9 [.22]			1.0 [.25]					
	RPM	W	%	RPM	W	%	RPM	W	%	RPM	W	%	RPM	W	%	RPM	W	%	RPM	W	%	RPM	W	%	RPM	W	%	RPM	W	%	RPM	W	%
3200 [1510]	918	383	39.3	960	447	41.2	1004	517	43.1	1041	584	44.8	1077	652	46.4	1111	722	47.8	1138	787	49.1	1166	852	50.4	1197	923	51.6	1228	997	52.9			
3300 [1557]	943	412	40.3	983	478	42.2	1027	551	44.1	1064	619	45.8	1099	689	47.3	1132	761	48.8	1158	826	50.0	1186	894	51.3	1217	966	52.5	1247	1042	53.8			
3400 [1604]	967	443	41.4	1006	510	43.2	1050	585	45.1	1086	656	46.7	1121	728	48.3	1154	802	49.7	1179	868	50.9	1207	937	52.2	1237	1011	53.4	1267	1089	54.6			
3500 [1652]	992	475	42.5	1030	544	44.2	1073	622	46.1	1109	694	47.7	1143	768	49.2	1175	844	50.7	1199	911	51.9	1227	982	53.1	1257	1057	54.2	1286	1137	55.5			
3600 [1699]	1016	509	43.5	1054	579	45.3	1096	659	47.1	1132	734	48.7	1165	810	50.2	1197	888	51.6	1220	955	52.8	1248	1029	54.0	1277	1105	55.2	1306	1186	56.5			
3700 [1746]	1041	545	44.6	1077	616	46.3	1120	699	48.1	1155	776	49.7	1188	854	51.1	1219	933	52.5	1241	1001	53.7	1269	1077	54.9	1297	1155	56.1	1326	1238	57.4			
3800 [1793]	1065	582	45.7	1101	655	47.3	1143	740	49.1	1177	819	50.7	1210	899	52.1	1241	980	53.5	1262	1048	54.6	1290	1126	55.9	1318	1206	57.0	1346	1291	58.3			
3900 [1840]	1090	621	46.7	1124	695	48.3	1166	782	50.1	1200	864	51.6	1233	946	53.0	1263	1029	54.4	1283	1098	55.6	1311	1178	56.8	1339	1259	58.0	1367	1346	59.3			
4000 [1888]	1114	661	47.8	1148	736	49.4	1189	826	51.1	1223	911	52.6	1255	994	54.0	1285	1079	55.4	1305	1148	56.5	1332	1231	57.8	1359	1314	59.0	1387	1402	60.3			
4100 [1935]	1139	703	48.9	1172	779	50.4	1213	871	52.1	1247	959	53.6	1278	1045	54.9	1308	1130	56.3	1326	1200	57.4	1354	1285	58.7	1381	1371	60.0	1408	1460	61.3			
4200 [1982]	1164	746	50.0	1196	824	51.4	1236	919	53.1	1270	1008	54.5	1301	1096	55.9	1330	1184	57.3	1348	1254	58.4	1375	1341	59.7	1402	1429	61.0	1429	1520	62.4			
4300 [2029]	1188	791	51.1	1219	870	52.5	1260	967	54.1	1293	1060	55.5	1324	1150	56.8	1353	1239	58.3	1369	1309	59.3	1397	1399	60.7	1423	1488	62.0	1450	1581	63.4			
4400 [2076]	1213	837	52.1	1243	918	53.5	1283	1017	55.1	1317	1113	56.5	1347	1204	57.8	1376	1295	59.2	1391	1366	60.3	1419	1459	61.7	1445	1550	63.1	1471	1644	64.5			
4500 [2123]	1238	885	53.2	1267	967	54.6	1307	1069	56.1	1340	1167	57.4	1370	1261	58.7	1399	1353	60.2	1413	1424	61.2	1442	1520	62.7	1467	1613	64.1	1493	1709	65.6			
4600 [2171]	1262	935	54.3	1291	1018	55.6	1331	1122	57.1	1364	1223	58.4	1393	1319	59.7	1422	1413	61.1	1436	1484	62.2	1464	1582	63.7	1489	1677	65.2	1514	1775	66.7			
4700 [2218]	1287	986	55.4	1315	1070	56.7	1354	1177	58.1	1387	1281	59.3	1417	1379	60.6	1445	1475	62.1	1458	1546	63.1	1487	1647	64.8	1511	1743	66.3	1536	1843	67.9			
4800 [2265]	1312	1039	56.5	1339	1124	57.7	1378	1233	59.1	1411	1340	60.3	1440	1440	61.5	1468	1538	63.1	1480	1609	64.1	1510	1713	65.8	1534	1811	67.4	1558	1912	69.0			

Air Flow	Model RHPDYC0120 Voltage 208/230 — 3 phase 60 Hz																																			
	External Static Pressure—Inches of Water [kPa]																																			
	1.1 [.27]			1.2 [.30]			1.3 [.32]			1.4 [.35]			1.5 [.37]			1.6 [.40]			1.7 [.42]			1.8 [.45]			1.9 [.47]			2.0 [.50]								
	RPM	W	%	RPM	W	%	RPM	W	%	RPM	W	%	RPM	W	%	RPM	W	%	RPM	W	%	RPM	W	%	RPM	W	%	RPM	W	%	RPM	W	%	RPM	W	%
3200 [1510]	1257	1071	54.1	1287	1147	55.5	1315	1222	56.7	1343	1298	58.1	1370	1377	59.4	1402	1464	60.9	1428	1545	62.1	1452	1625	63.3	1478	1715	64.9	1504	1806	66.4						
3300 [1557]	1276	1117	55.0	1306	1195	56.3	1333	1272	57.6	1361	1349	58.9	1388	1430	60.2	1420	1520	61.8	1445	1603	63.1	1469	1684	64.3	1495	1776	65.9	1521	1870	67.4						
3400 [1604]	1295	1165	55.8	1324	1245	57.1	1352	1324	58.4	1379	1403	59.8	1406	1486	61.1	1438	1578	62.7	1463	1662	64.0	1487	1745	65.4	1512	1840	66.9	1538	1936	68.5						
3500 [1652]	1314	1214	56.7	1343	1296	58.0	1370	1377	59.3	1398	1458	60.7	1424	1543	62.1	1456	1638	63.6	1481	1723	65.0	1504	1807	66.4	1530	1905	68.0	1556	2004	69.5						
3600 [1699]	1334	1266	57.6	1362	1350	59.0	1389	1433	60.3	1416	1515	61.6	1442	1602	63.0	1474	1700	64.6	1499	1786	66.0	1522	1872	67.5	1547	1972	69.0	1573	2074	70.5						
3700 [1746]	1353	1319	58.5	1382	1405	59.9	1408	1490	61.2	1435	1574	62.6	1461	1663	64.0	1493	1763	65.6	1517	1851	67.0	1540	1938	68.5	1565	2041	70.0	1591	2146	71.6						
3800 [1793]	1373	1374	59.5	1401	1462	60.9	1428	1548	62.2	1454	1635	63.6	1479	1725	65.0	1511	1829	66.7	1535	1918	68.1	1558	2007	69.6	1583	2112	71.1	1609	2219	72.6						
3900 [1840]	1393	1431	60.5	1421	1521	61.9	1447	1609	63.3	1473	1698	64.6	1498	1790	66.1	1530	1896	67.7	1553	1987	69.1	1576	2077	70.6	1601	2184	72.1	1627	2294	73.6						
4000 [1888]	1413	1489	61.5	1441	1581	62.9	1467	1671	64.3	1493	1763	65.7	1517	1856	67.1	1549	1965	68.8	1572	2058	70.2	1594	2150	71.7	1619	2259	73.1	1645	2370	74.6						
4100 [1935]	1434	1550	62.6	1461	1643	64.0	1486	1735	65.4	1512	1829	66.8	1537	1925	68.2	1568	2036	69.9	1591	2131	71.3	1613	2224	72.7	1637	2335	74.2	1663	2449	75.7						
4200 [1982]	1455	1612	63.7	1481	1707	65.1	1506	1801	66.5	1532	1898	67.9	1556	1995	69.4	1587	2109	71.0	1610	2205	72.4	1631	2300	73.8	1656	2413	75.2	1681	2529	76.7						
4300 [2029]	1475	1676	64.8	1502	1773	66.3	1527	1868	67.7	1552	1968	69.1	1575	2067	70.5	1607	2183	72.2	1629	2282	73.5	1650	2379	74.8	1674	2494	76.2	1699	2611	77.7						
4400 [2076]	1497	1742	65.9	1523	1841	67.4	1547	1937	68.9	1572	2040	70.3	1595	2140	71.7	1626	2260	73.4	1648	2360	74.7	1669	2459	75.9	1693	2576	77.2	1718	2694	78.7						
4500 [2123]	1518	1809	67.1	1544	1910	68.6	1568	2008	70.1	1592	2114	71.5	1615	2216	72.9	1646	2338	74.6	1668	2441	75.8	1688	2541	76.9	1712	2659	78.3	1736	2780	79.7						
4600 [2171]	1539	1878	68.3	1565	1981	69.9	1589	2081	71.3	1613	2190	72.8	1635	2294	74.2	1666	2418	75.8	1687	2523	77.0	1708	2626	78.0	1731	2745	79.3	1755	2867	80.7						
4700 [2218]	1561	1949	69.6	1586	2054	71.1	1610	2156	72.6	1634	2268	74.0	1656	2373	75.4	1686	2500	77.1	1707	2607	78.2	1727	2712	79.1	1750	2833	80.3	1774	2956	81.7						
4800 [2265]	1583	2022	70.8	1608	2129	72.4	1631	2232	73.9	1655	2348	75.4	1676	2454	76.7	1706	2584	78.3	1727	2693	79.4	1747	2800	80.1	1769	2922	81.3	1792	3046	82.6						

NOTES: 1. Factory airflow setting of VDC (%) at AHRI minimum External Static Pressure. Adjust VDC (%) value to achieve desire airflow.
 2. Do not set outside range of VDC (%) values from the values shown in Table
 3. Drive data is for Sideflow/Downflow with dry coil. Add component resistance (below) to determine total External Static Pressure

AIRFLOW PERFORMANCE — 10 TON — 60 Hz — 208/230V — DOWNFLOW (CONTINUED)

Airflow	AIRFLOW CORRECTION FACTORS*			COMPONENT AIRFLOW RESISTANCE					
				Wet Coil	Horizontal Economizer RA Damper Open	Concentric Diffuser RXRN-AEF3415 & Concentric Adapter RXMC-DD02 (Flush)	Concentric Diffuser RXRN-AED3415 & Concentric Adapter RXMC-DD02 (Drop)	Pressure Drop MERV 8	Pressure Drop MERV 13
CFM [L/s]	Total kBtu/h	Sensible kBtu/h	Power kW	Resistance — Inches of Water [kPa]					
3200 [1510]	1.04	1.09	1.03	0.14 [.04]	0.28 [.07]	1.59 [.40]	1.19 [.30]	0.164 [.04]	0.157 [.04]
3300 [1557]	1.03	1.07	1.02	0.13 [.03]	0.24 [.06]	1.48 [.37]	1.11 [.28]	0.156 [.04]	0.145 [.04]
3400 [1604]	1.03	1.08	1.03	0.14 [.03]	0.26 [.06]	1.54 [.38]	1.15 [.29]	0.160 [.04]	0.151 [.04]
3500 [1652]	1.02	1.05	1.02	0.12 [.03]	0.21 [.05]	1.37 [.34]	1.02 [.25]	0.148 [.04]	0.132 [.03]
3600 [1699]	1.02	1.06	1.02	0.13 [.03]	0.23 [.06]	1.43 [.35]	1.07 [.27]	0.152 [.04]	0.138 [.03]
3700 [1746]	1.01	1.02	1.01	0.11 [.03]	0.19 [.05]	1.24 [.31]	0.92 [.23]	0.140 [.03]	0.120 [.03]
3800 [1793]	1.01	1.03	1.01	0.11 [.03]	0.20 [.05]	1.31 [.33]	0.97 [.24]	0.144 [.03]	0.126 [.03]
3900 [1840]	1.00	0.99	1.00	0.09 [.02]	0.15 [.04]	1.09 [.27]	0.80 [.20]	0.128 [.03]	0.102 [.02]
4000 [1888]	1.00	1.00	1.01	0.10 [.02]	0.16 [.04]	1.13 [.28]	0.84 [.21]	0.132 [.03]	0.108 [.03]
4100 [1935]	1.00	1.01	1.01	0.10 [.03]	0.17 [.04]	1.19 [.30]	0.88 [.22]	0.136 [.03]	0.114 [.03]
4200 [1982]	0.99	0.97	1.00	0.09 [.02]	0.12 [.03]	1.00 [.25]	0.73 [.18]	0.120 [.03]	0.089 [.02]
4300 [2029]	0.99	0.98	1.00	0.09 [.02]	0.13 [.03]	1.04 [.26]	0.76 [.19]	0.124 [.03]	0.095 [.02]
4400 [2076]	0.98	0.94	0.99	0.08 [.02]	0.10 [.02]	0.90 [.22]	0.66 [.16]	0.112 [.03]	0.077 [.02]
4500 [2123]	0.98	0.95	0.99	0.08 [.02]	0.11 [.03]	0.95 [.24]	0.69 [.17]	0.116 [.03]	0.083 [.02]
4600 [2171]	0.97	0.92	0.99	0.07 [.02]	0.08 [.02]	0.79 [.20]	0.59 [.15]	0.104 [.03]	0.065 [.02]
4700 [2218]	0.97	0.93	0.99	0.07 [.02]	0.09 [.02]	0.84 [.21]	0.62 [.15]	0.108 [.03]	0.071 [.02]
4800 [2265]	0.96	0.91	0.98	0.07 [.02]	0.07 [.02]	0.74 [.18]	0.56 [.14]	0.100 [.02]	0.058 [.02]

*Multiply correction factor times gross performance data resulting sensible capacity cannot exceed total capacity.

[] Designates Metric Conversions

AIRFLOW PERFORMANCE — 10 TON — 60 Hz — 208/230V — SIDEFLOW

Air Flow	Model RHPDYC0120 Voltage 208/230 — 3 phase 60 Hz																																
	External Static Pressure—Inches of Water [kPa]																																
	0.1 [.02]			0.2 [.05]			0.3 [.07]			0.4 [.010]			0.5 [.12]			0.6 [.15]			0.7 [.17]			0.8 [.20]			0.9 [.22]			1.0 [.25]					
	RPM	W	%	RPM	W	%	RPM	W	%	RPM	W	%	RPM	W	%	RPM	W	%	RPM	W	%	RPM	W	%	RPM	W	%	RPM	W	%	RPM	W	%
3200 [1510]	902	363	38.6	938	417	40.2	973	474	41.8	1010	536	43.5	1037	588	44.7	1075	657	46.4	1106	719	47.7	1138	784	49.0	1167	848	50.3	1189	900	51.2			
3300 [1557]	927	390	39.6	961	446	41.2	996	505	42.8	1032	569	44.4	1058	622	45.7	1096	693	47.3	1127	757	48.6	1157	822	49.9	1186	888	51.2	1207	941	52.0			
3400 [1604]	951	420	40.7	984	477	42.2	1019	538	43.8	1054	603	45.4	1080	658	46.6	1117	730	48.2	1147	796	49.5	1177	863	50.8	1205	930	52.0	1225	983	52.9			
3500 [1652]	975	450	41.7	1008	509	43.2	1042	572	44.8	1076	638	46.3	1101	695	47.5	1138	769	49.2	1167	836	50.4	1197	905	51.6	1225	973	52.9	1244	1027	53.7			
3600 [1699]	1000	483	42.8	1031	542	44.3	1066	608	45.8	1099	675	47.3	1123	733	48.5	1159	810	50.1	1188	878	51.3	1217	948	52.5	1244	1018	53.8	1263	1073	54.6			
3700 [1746]	1024	517	43.8	1055	577	45.3	1089	646	46.8	1121	714	48.3	1145	774	49.4	1180	852	51.0	1209	922	52.2	1237	993	53.4	1264	1065	54.7	1283	1121	55.4			
3800 [1793]	1049	552	44.9	1078	614	46.3	1113	685	47.8	1143	754	49.2	1167	815	50.4	1202	895	51.9	1230	967	53.1	1258	1040	54.3	1285	1113	55.6	1302	1171	56.3			
3900 [1840]	1073	589	46.0	1102	652	47.3	1136	726	48.9	1166	795	50.2	1189	859	51.3	1224	940	52.8	1252	1014	54.0	1279	1088	55.2	1305	1163	56.5	1322	1222	57.3			
4000 [1888]	1098	628	47.0	1126	692	48.4	1160	768	49.9	1189	838	51.2	1211	904	52.3	1246	987	53.7	1273	1062	55.0	1300	1138	56.1	1326	1214	57.4	1343	1275	58.2			
4100 [1935]	1122	668	48.1	1150	733	49.4	1184	812	50.9	1211	883	52.2	1233	950	53.2	1268	1035	54.6	1295	1113	55.9	1321	1190	57.1	1347	1267	58.3	1363	1330	59.1			
4200 [1982]	1147	709	49.2	1174	776	50.5	1208	858	52.0	1234	929	53.1	1256	998	54.2	1290	1085	55.5	1317	1164	56.8	1342	1243	58.0	1368	1322	59.2	1384	1387	60.1			
4300 [2029]	1172	753	50.3	1198	821	51.5	1233	905	53.0	1257	976	54.1	1279	1048	55.1	1312	1137	56.4	1339	1217	57.7	1364	1297	58.9	1389	1378	60.2	1405	1446	61.1			
4400 [2076]	1196	797	51.4	1222	867	52.6	1257	954	54.1	1280	1025	55.1	1302	1099	56.1	1335	1190	57.4	1361	1272	58.6	1386	1354	59.9	1411	1436	61.1	1427	1507	62.1			
4500 [2123]	1221	844	52.5	1246	914	53.7	1282	1005	55.1	1304	1076	56.1	1325	1152	57.0	1358	1244	58.3	1384	1329	59.5	1408	1412	60.8	1433	1496	62.1	1448	1569	63.1			
4600 [2171]	1246	891	53.6	1271	963	54.7	1306	1057	56.2	1327	1128	57.1	1348	1206	58.0	1381	1301	59.2	1407	1387	60.5	1431	1471	61.8	1455	1557	63.1	1470	1633	64.2			
4700 [2218]	1271	941	54.7	1295	1014	55.8	1331	1110	57.3	1350	1181	58.1	1371	1262	58.9	1404	1358	60.1	1430	1446	61.4	1453	1532	62.8	1477	1620	64.1	1493	1699	65.2			
4800 [2265]	1296	992	55.8	1319	1066	56.9	1356	1166	58.3	1373	1237	59.1	1394	1320	59.9	1427	1418	61.0	1453	1507	62.3	1476	1595	63.7	1500	1684	65.1	1515	1767	66.3			

Air Flow	Model RHPDYC0120 Voltage 208/230 — 3 phase 60 Hz																																			
	External Static Pressure—Inches of Water [kPa]																																			
	1.1 [.27]			1.2 [.30]			1.3 [.32]			1.4 [.35]			1.5 [.37]			1.6 [.40]			1.7 [.42]			1.8 [.45]			1.9 [.47]			2.0 [.50]								
	RPM	W	%	RPM	W	%	RPM	W	%	RPM	W	%	RPM	W	%	RPM	W	%	RPM	W	%	RPM	W	%	RPM	W	%	RPM	W	%	RPM	W	%	RPM	W	%
3200 [1510]	1226	981	52.8	1253	1048	53.9	1283	1122	55.1	1310	1195	56.3	1328	1256	57.2	1362	1341	58.7	1388	1417	60.0	1413	1498	61.3	1438	1578	62.6	1454	1648	63.6						
3300 [1557]	1244	1024	53.6	1271	1091	54.7	1301	1167	55.9	1328	1241	57.0	1345	1303	58.0	1379	1390	59.5	1404	1468	60.8	1430	1551	62.2	1454	1634	63.5	1470	1706	64.5						
3400 [1604]	1262	1068	54.4	1289	1137	55.5	1318	1214	56.7	1345	1290	57.8	1362	1352	58.8	1396	1442	60.3	1421	1521	61.7	1446	1606	63.1	1471	1692	64.5	1487	1765	65.5						
3500 [1652]	1281	1114	55.2	1307	1184	56.3	1336	1262	57.5	1363	1340	58.7	1379	1403	59.6	1413	1495	61.2	1438	1577	62.6	1463	1663	64.0	1488	1751	65.4	1503	1825	66.4						
3600 [1699]	1299	1162	56.1	1326	1234	57.2	1354	1313	58.4	1380	1392	59.5	1396	1455	60.4	1431	1551	62.1	1455	1633	63.5	1480	1722	64.9	1505	1812	66.3	1520	1887	67.4						
3700 [1746]	1318	1211	57.0	1344	1285	58.1	1373	1366	59.3	1398	1446	60.4	1414	1510	61.3	1448	1608	63.0	1473	1692	64.4	1497	1782	65.9	1522	1874	67.3	1537	1950	68.3						
3800 [1793]	1338	1262	57.9	1364	1339	59.0	1391	1420	60.2	1417	1501	61.4	1432	1567	62.3	1466	1667	64.0	1490	1753	65.4	1515	1845	66.8	1539	1938	68.3	1554	2015	69.3						
3900 [1840]	1357	1316	58.8	1383	1394	59.9	1410	1477	61.2	1435	1559	62.3	1450	1625	63.2	1484	1729	65.0	1508	1816	66.4	1532	1909	67.8	1556	2004	69.3	1570	2081	70.3						
4000 [1888]	1377	1371	59.8	1403	1451	60.9	1429	1536	62.2	1454	1619	63.4	1468	1686	64.2	1502	1792	66.0	1525	1880	67.4	1550	1975	68.8	1574	2072	70.3	1587	2148	71.3						
4100 [1935]	1397	1427	60.7	1423	1511	62.0	1449	1596	63.2	1473	1680	64.4	1486	1748	65.3	1520	1857	67.1	1543	1947	68.5	1567	2043	69.9	1591	2141	71.3	1604	2216	72.3						
4200 [1982]	1418	1486	61.7	1443	1572	63.0	1468	1659	64.3	1492	1744	65.5	1505	1812	66.3	1538	1924	68.2	1561	2015	69.5	1585	2112	70.9	1609	2213	72.3	1621	2285	73.2						
4300 [2029]	1438	1546	62.7	1464	1635	64.1	1488	1723	65.4	1511	1809	66.6	1524	1878	67.4	1557	1993	69.3	1580	2085	70.6	1603	2184	72.0	1627	2285	73.4	1638	2357	74.2						
4400 [2076]	1459	1608	63.8	1485	1700	65.2	1508	1789	66.5	1530	1877	67.8	1543	1946	68.6	1576	2064	70.5	1598	2157	71.7	1621	2257	73.1	1644	2360	74.4	1655	2429	75.3						
4500 [2123]	1480	1672	64.8	1506	1768	66.3	1529	1858	67.7	1550	1946	69.0	1562	2016	69.8	1595	2137	71.7	1616	2231	72.9	1639	2332	74.2	1662	2436	75.5	1673	2503	76.3						
4600 [2171]	1501	1738	65.9	1527	1837	67.5	1549	1928	68.9	1570	2017	70.2	1581	2088	71.0	1614	2212	73.0	1635	2307	74.1	1658	2409	75.4	1680	2514	76.6	1690	2578	77.3						
4700 [2218]	1523	1805	67.0	1549	1908	68.7	1570	2000	70.1	1590	2090	71.5	1601	2162	72.2	1633	2289	74.2	1654	2385	75.3	1676	2487	76.5	1698	2593	77.7	1707	2654	78.3						
4800 [2265]	1545	1875	68.1	1571	1981	70.0	1592	2074	71.4	1610	2165	72.8	1621	2237	73.5	1653	2367	75.5	1673	2465	76.5	1695	2568	77.7	1717	2675	78.8	1724	2731	79.4						

- NOTES:**
1. Factory airflow setting of VDC (%) at AHRI minimum External Static Pressure. Adjust VDC (%) value to achieve desire airflow.
 2. Do not set outside range of VDC (%) values from the values shown in Table
 3. Drive data is for Sideflow/Downflow with dry coil. Add component resistance (below) to determine total External Static Pressure

AIRFLOW PERFORMANCE — 10 TON — 60 Hz — 208/230V — SIDEFLOW (CONTINUED)

Airflow	AIRFLOW CORRECTION FACTORS*			COMPONENT AIRFLOW RESISTANCE					
				Wet Coil	Horizontal Economizer RA Damper Open	Concentric Diffuser RXRN-AEF3415 & Concentric Adapter RXMC-DD02 (Flush)	Concentric Diffuser RXRN-AED3415 & Concentric Adapter RXMC-DD02 (Drop)	Pressure Drop MERV 8	Pressure Drop MERV 13
CFM [L/s]	Total kBtu/h	Sensible kBtu/h	Power kW	Resistance — Inches of Water [kPa]					
3200 [1510]	0.96	0.91	0.98	0.07 [.02]	0.31 [0.08]	0.74 [.18]	0.56 [.14]	0.100 [.02]	0.058 [.02]
3300 [1557]	0.97	0.92	0.99	0.07 [.02]	0.36 [0.09]	0.79 [.20]	0.59 [.15]	0.104 [.03]	0.065 [.02]
3400 [1604]	0.97	0.93	0.99	0.07 [.02]	0.42 [0.10]	0.84 [.21]	0.62 [.15]	0.108 [.03]	0.071 [.02]
3500 [1652]	0.98	0.94	0.99	0.08 [.02]	0.47 [0.12]	0.90 [.22]	0.66 [.16]	0.112 [.03]	0.077 [.02]
3600 [1699]	0.98	0.95	0.99	0.08 [.02]	0.52 [0.13]	0.95 [.24]	0.69 [.17]	0.116 [.03]	0.083 [.02]
3700 [1746]	0.99	0.97	1.00	0.09 [.02]	0.58 [0.14]	1.00 [.25]	0.73 [.18]	0.120 [.03]	0.089 [.02]
3800 [1793]	0.99	0.98	1.00	0.09 [.02]	0.63 [0.16]	1.04 [.26]	0.76 [.19]	0.124 [.03]	0.095 [.02]
3900 [1840]	1.00	0.99	1.00	0.09 [.02]	0.68 [0.17]	1.09 [.27]	0.80 [.20]	0.128 [.03]	0.102 [.02]
4000 [1888]	1.00	1.00	1.01	0.10 [.02]	0.73 [0.18]	1.13 [.28]	0.84 [.21]	0.132 [.03]	0.108 [.03]
4100 [1935]	1.00	1.01	1.01	0.10 [.03]	0.78 [0.19]	1.19 [.30]	0.88 [.22]	0.136 [.03]	0.114 [.03]
4200 [1982]	1.01	1.02	1.01	0.11 [.03]	0.83 [0.21]	1.24 [.31]	0.92 [.23]	0.140 [.03]	0.120 [.03]
4300 [2029]	1.01	1.03	1.01	0.11 [.03]	0.88 [0.22]	1.31 [.33]	0.97 [.24]	0.144 [.03]	0.126 [.03]
4400 [2076]	1.02	1.05	1.02	0.12 [.03]	0.93 [0.23]	1.37 [.34]	1.02 [.25]	0.148 [.04]	0.132 [.03]
4500 [2123]	1.02	1.06	1.02	0.13 [.03]	0.98 [0.24]	1.43 [.35]	1.07 [.27]	0.152 [.04]	0.138 [.03]
4600 [2171]	1.03	1.07	1.02	0.13 [.03]	1.03 [0.26]	1.48 [.37]	1.11 [.28]	0.156 [.04]	0.145 [.04]
4700 [2218]	1.03	1.08	1.03	0.14 [.03]	1.07 [0.27]	1.54 [.38]	1.15 [.29]	0.160 [.04]	0.151 [.04]
4800 [2265]	1.04	1.09	1.03	0.14 [.04]	1.12 [0.28]	1.59 [.40]	1.19 [.30]	0.164 [.04]	0.157 [.04]

*Multiply correction factor times gross performance data resulting sensible capacity cannot exceed total capacity.

[] Designates Metric Conversions

AIRFLOW PERFORMANCE — 10 TON — 60 Hz — 460V — DOWNFLOW

Air Flow	Model RHPDYC0120 Voltage 460 — 3 phase 60 Hz																																
	External Static Pressure—Inches of Water [kPa]																																
	0.1 [.02]			0.2 [.05]			0.3 [.07]			0.4 [.10]			0.5 [.12]			0.6 [.15]			0.7 [.17]			0.8 [.20]			0.9 [.22]			1.0 [.25]					
	RPM	W	%	RPM	W	%	RPM	W	%	RPM	W	%	RPM	W	%	RPM	W	%	RPM	W	%	RPM	W	%	RPM	W	%	RPM	W	%	RPM	W	%
3200 [1510]	929	432	35.8	965	493	37.3	1005	558	38.9	1033	613	40.2	1066	675	41.5	1100	742	42.9	1126	802	44.0	1160	868	45.4	1187	933	46.6	1210	989	47.6			
3300 [1557]	952	459	36.7	988	522	38.2	1028	592	39.8	1063	657	41.3	1088	711	42.4	1121	779	43.8	1145	836	44.8	1182	913	46.3	1206	975	47.4	1229	1033	48.4			
3400 [1604]	979	494	37.8	1013	557	39.2	1051	625	40.7	1085	691	42.1	1112	752	43.4	1143	819	44.7	1168	881	45.8	1203	959	47.2	1230	1028	48.4	1251	1084	49.3			
3500 [1652]	1004	528	38.8	1037	590	40.1	1073	660	41.6	1108	729	43.0	1131	788	44.2	1164	860	45.6	1189	923	46.7	1222	1000	48.0	1250	1073	49.2	1272	1133	50.1			
3600 [1699]	1028	559	39.7	1060	625	41.0	1096	697	42.5	1132	772	44.0	1155	831	45.2	1186	901	46.5	1210	967	47.6	1237	1037	48.7	1271	1122	50.0	1293	1183	50.9			
3700 [1746]	1051	592	40.6	1085	664	42.0	1120	737	43.5	1156	815	45.0	1178	870	46.1	1209	950	47.5	1235	1019	48.6	1256	1080	49.5	1290	1168	50.8	1313	1237	51.7			
3800 [1793]	1076	631	41.6	1106	697	42.8	1143	778	44.5	1178	855	45.9	1201	918	47.1	1236	1004	48.6	1255	1062	49.4	1276	1127	50.3	1313	1225	51.7	1335	1289	52.4			
3900 [1840]	1103	671	42.6	1132	742	43.9	1167	820	45.5	1203	903	47.0	1225	968	48.1	1260	1057	49.5	1279	1115	50.3	1299	1182	51.2	1333	1274	52.4	1354	1340	53.1			
4000 [1888]	1125	708	43.5	1158	787	45.0	1191	866	46.5	1224	946	47.9	1255	1024	49.2	1283	1107	50.4	1300	1164	51.1	1321	1233	52.0	1353	1328	53.1	1376	1399	53.8			
4100 [1935]	1148	748	44.5	1184	836	46.1	1213	907	47.4	1247	991	48.8	1278	1075	50.1	1304	1160	51.2	1323	1220	52.0	1344	1292	52.8	1375	1384	53.8	1398	1462	54.5			
4200 [1982]	1173	790	45.5	1206	876	47.0	1234	950	48.3	1271	1046	49.8	1302	1129	51.0	1327	1209	52.0	1343	1270	52.7	1366	1348	53.5	1398	1447	54.5	1418	1518	55.2			
4300 [2029]	1199	840	46.6	1229	922	48.0	1251	989	49.1	1295	1096	50.7	1323	1178	51.8	1353	1272	52.9	1368	1334	53.5	1388	1407	54.2	1419	1506	55.2	1440	1581	56.0			
4400 [2076]	1223	884	47.6	1251	964	48.9	1277	1041	50.1	1313	1137	51.4	1349	1242	52.7	1376	1331	53.6	1386	1379	54.1	1409	1464	54.9	1438	1562	55.9	1463	1650	57.0			
4500 [2123]	1251	942	48.8	1276	1015	49.9	1300	1092	51.0	1339	1198	52.3	1372	1297	53.4	1395	1380	54.2	1411	1447	54.9	1431	1523	55.6	1459	1625	56.8	1485	1719	58.2			
4600 [2171]	1275	992	49.8	1304	1079	51.0	1324	1147	51.9	1365	1265	53.2	1392	1351	54.1	1415	1435	54.9	1446	1539	56.1	1455	1593	56.6	1481	1687	57.9	1505	1780	59.3			
4700 [2218]	1301	1046	50.8	1328	1130	51.9	1354	1215	52.9	1388	1317	53.9	1414	1405	54.8	1441	1503	55.8	1471	1614	57.2	1475	1654	57.6	1508	1777	59.4	1528	1859	60.6			
4800 [2265]	1325	1097	51.7	1352	1184	52.7	1371	1257	53.4	1409	1374	54.6	1439	1473	55.7	1466	1574	56.9	1498	1696	58.6	1501	1734	59.0	1528	1840	60.5	1548	1927	61.8			

Air Flow	Model RHPDYC0120 Voltage 460 — 3 phase 60 Hz																																			
	External Static Pressure—Inches of Water [kPa]																																			
	1.1 [.27]			1.2 [.30]			1.3 [.32]			1.4 [.35]			1.5 [.37]			1.6 [.40]			1.7 [.42]			1.8 [.45]			1.9 [.47]			2.0 [.50]								
	RPM	W	%	RPM	W	%	RPM	W	%	RPM	W	%	RPM	W	%	RPM	W	%	RPM	W	%	RPM	W	%	RPM	W	%	RPM	W	%	RPM	W	%	RPM	W	%
3200 [1510]	1241	1062	48.9	1270	1132	50.1	1302	1209	51.3	1341	1300	52.6	1368	1372	53.4	1380	1421	53.9	1410	1509	54.8	1424	1562	55.3	1447	1637	56.3	1469	1712	57.3						
3300 [1557]	1261	1109	49.7	1291	1184	50.9	1319	1257	52.0	1361	1357	53.3	1388	1432	54.1	1396	1474	54.4	1424	1558	55.3	1443	1625	56.1	1464	1700	57.1	1487	1776	58.3						
3400 [1604]	1281	1158	50.5	1308	1228	51.6	1337	1302	52.6	1380	1411	53.9	1404	1478	54.6	1416	1532	55.1	1439	1609	56.0	1460	1678	56.8	1481	1758	58.0	1506	1843	59.4						
3500 [1652]	1301	1209	51.3	1329	1281	52.3	1357	1360	53.3	1400	1468	54.5	1422	1533	55.2	1437	1593	55.8	1459	1670	56.8	1477	1738	57.7	1502	1826	59.2	1525	1909	60.5						
3600 [1699]	1321	1257	52.0	1353	1343	53.1	1377	1413	53.9	1418	1519	55.1	1442	1597	56.0	1457	1660	56.7	1479	1735	57.8	1498	1809	58.9	1521	1893	60.3	1543	1976	61.6						
3700 [1746]	1343	1317	52.8	1372	1397	53.7	1398	1470	54.5	1438	1578	55.8	1461	1657	56.8	1474	1714	57.5	1498	1799	58.9	1516	1870	59.9	1538	1959	61.3	1561	2003	62.5						
3800 [1793]	1365	1374	53.5	1393	1456	54.4	1419	1532	55.2	1456	1637	56.6	1480	1720	57.8	1495	1785	58.7	1519	1872	60.1	1532	1935	60.9	1556	1978	62.2	1581	2073	63.4						
3900 [1840]	1388	1436	54.2	1413	1511	55.0	1440	1598	56.0	1471	1690	57.4	1499	1785	58.9	1511	1846	59.7	1537	1937	61.2	1552	2007	62.1	1574	2048	63.1	1598	2137	64.2						
4000 [1888]	1413	1508	55.0	1431	1566	55.7	1460	1659	56.9	1491	1755	58.5	1519	1851	60.0	1536	1928	61.1	1557	1968	62.2	1570	2036	62.9	1588	2109	63.8	1619	2217	65.1						
4100 [1935]	1431	1557	55.6	1458	1645	56.8	1482	1727	58.0	1511	1824	59.7	1540	1927	61.3	1558	1965	62.2	1576	2036	63.1	1590	2107	63.8	1612	2191	64.8	1636	2291	65.9						
4200 [1982]	1453	1623	56.5	1479	1710	57.9	1509	1809	59.5	1539	1917	61.3	1566	1976	62.6	1578	2039	63.2	1599	2123	64.2	1609	2179	64.6	1629	2263	65.6	1657	2373	66.8						
4300 [2029]	1477	1698	57.7	1501	1778	59.1	1527	1872	60.6	1553	1966	62.1	1579	2023	63.2	1596	2105	64.0	1615	2184	64.9	1628	2251	65.5	1651	2349	66.6	1672	2438	67.5						
4400 [2076]	1497	1758	58.7	1525	1854	60.4	1551	1954	62.0	1577	2009	63.1	1603	2107	64.3	1616	2181	64.9	1635	2261	65.8	1645	2322	66.3	1662	2410	67.1	1692	2520	68.4						
4500 [2123]	1520	1836	60.1	1547	1931	61.7	1573	1984	62.9	1603	2099	64.3	1626	2193	65.3	1639	2267	65.9	1656	2343	66.7	1666	2405	67.2	1687	2503	68.2	1712	2610	69.2						
4600 [2171]	1549	1932	61.8	1569	1964	62.7	1594	2057	63.9	1620	2157	65.0	1636	2237	65.8	1657	2339	66.7	1673	2415	67.5	1689	2500	68.2	1708	2591	69.1	1732	2694	70.0						
4700 [2218]	1571	1963	62.8	1594	2048	63.8	1619	2142	64.9	1643	2239	66.0	1657	2316	66.7	1677	2412	67.6	1693	2496	68.4	1705	2568	68.9	1726	2662	69.8	1751	2779	70.8						
4800 [2265]	1591	2034	63.7	1616	2122	64.7	1639	2215	65.8	1666	2327	67.0	1678	2400	67.6	1701	2506	68.6	1717	2592	69.3	1722	2639	69.6	1749	2761	70.7	1771	2864	71.7						

- NOTES:** 1. Factory airflow setting of VDC (%) at AHRI minimum External Static Pressure. Adjust VDC (%) value to achieve desire airflow.
 2. Do not set outside range of VDC (%) values from the values shown in Table
 3. Drive data is for Sideflow/Downflow with dry coil. Add component resistance (below) to determine total External Static Pressure

AIRFLOW PERFORMANCE — 10 TON — 60 Hz — 460V — DOWNFLOW (CONTINUED)

Airflow	AIRFLOW CORRECTION FACTORS *			COMPONENT AIRFLOW RESISTANCE					
				Wet Coil	Horizontal Economizer RA Damper Open	Concentric Diffuser RXRN-AEF3415 & Concentric Adapter RXMC-DD02 (Flush)	Concentric Diffuser RXRN-AED3415 & Concentric Adapter RXMC-DD02 (Drop)	Pressure Drop MERV 8	Pressure Drop MERV 13
CFM [L/s]	Total kBtu/h	Sensible kBtu/h	Power kW	Resistance — Inches of Water [kPa]					
3200 [1510]	1.04	1.09	1.03	0.14 [.04]	0.28 [.07]	1.59 [.40]	1.19 [.30]	0.164 [.04]	0.157 [.04]
3300 [1557]	1.03	1.07	1.02	0.13 [.03]	0.24 [.06]	1.48 [.37]	1.11 [.28]	0.156 [.04]	0.145 [.04]
3400 [1604]	1.03	1.08	1.03	0.14 [.03]	0.26 [.06]	1.54 [.38]	1.15 [.29]	0.160 [.04]	0.151 [.04]
3500 [1652]	1.02	1.05	1.02	0.12 [.03]	0.21 [.05]	1.37 [.34]	1.02 [.25]	0.148 [.04]	0.132 [.03]
3600 [1699]	1.02	1.06	1.02	0.13 [.03]	0.23 [.06]	1.43 [.35]	1.07 [.27]	0.152 [.04]	0.138 [.03]
3700 [1746]	1.01	1.02	1.01	0.11 [.03]	0.19 [.05]	1.24 [.31]	0.92 [.23]	0.140 [.03]	0.120 [.03]
3800 [1793]	1.01	1.03	1.01	0.11 [.03]	0.20 [.05]	1.31 [.33]	0.97 [.24]	0.144 [.03]	0.126 [.03]
3900 [1840]	1.00	0.99	1.00	0.09 [.02]	0.15 [.04]	1.09 [.27]	0.80 [.20]	0.128 [.03]	0.102 [.02]
4000 [1888]	1.00	1.00	1.01	0.10 [.02]	0.16 [.04]	1.13 [.28]	0.84 [.21]	0.132 [.03]	0.108 [.03]
4100 [1935]	1.00	1.01	1.01	0.10 [.03]	0.17 [.04]	1.19 [.30]	0.88 [.22]	0.136 [.03]	0.114 [.03]
4200 [1982]	0.99	0.97	1.00	0.09 [.02]	0.12 [.03]	1.00 [.25]	0.73 [.18]	0.120 [.03]	0.089 [.02]
4300 [2029]	0.99	0.98	1.00	0.09 [.02]	0.13 [.03]	1.04 [.26]	0.76 [.19]	0.124 [.03]	0.095 [.02]
4400 [2076]	0.98	0.94	0.99	0.08 [.02]	0.10 [.02]	0.90 [.22]	0.66 [.16]	0.112 [.03]	0.077 [.02]
4500 [2123]	0.98	0.95	0.99	0.08 [.02]	0.11 [.03]	0.95 [.24]	0.69 [.17]	0.116 [.03]	0.083 [.02]
4600 [2171]	0.97	0.92	0.99	0.07 [.02]	0.08 [.02]	0.79 [.20]	0.59 [.15]	0.104 [.03]	0.065 [.02]
4700 [2218]	0.97	0.93	0.99	0.07 [.02]	0.09 [.02]	0.84 [.21]	0.62 [.15]	0.108 [.03]	0.071 [.02]
4800 [2265]	0.96	0.91	0.98	0.07 [.02]	0.07 [.02]	0.74 [.18]	0.56 [.14]	0.100 [.02]	0.058 [.02]

*Multiply correction factor times gross performance data resulting sensible capacity cannot exceed total capacity.

[] Designates Metric Conversions

AIRFLOW PERFORMANCE — 10 TON — 60 Hz — 460V — SIDEFLOW

Air Flow	Model RHPDYC0120 Voltage 460 — 3 phase 60 Hz																																
	External Static Pressure—Inches of Water [kPa]																																
	0.1 [.02]			0.2 [.05]			0.3 [.07]			0.4 [.10]			0.5 [.12]			0.6 [.15]			0.7 [.17]			0.8 [.20]			0.9 [.22]			1.0 [.25]					
	RPM	W	%	RPM	W	%	RPM	W	%	RPM	W	%	RPM	W	%	RPM	W	%	RPM	W	%	RPM	W	%	RPM	W	%	RPM	W	%	RPM	W	%
3200 [1510]	917	411	35.3	963	475	37.1	989	528	38.3	1021	584	39.5	1060	654	41.1	1083	704	42.1	1115	766	43.4	1145	831	44.7	1165	881	45.7	1204	962	47.2			
3300 [1557]	943	440	36.3	985	504	38.0	1011	558	39.2	1047	622	40.5	1081	686	41.9	1101	735	42.8	1135	802	44.2	1160	863	45.4	1184	920	46.5	1223	1003	48.0			
3400 [1604]	968	471	37.3	1007	535	38.9	1034	590	40.1	1066	653	41.3	1106	726	42.9	1124	776	43.8	1155	841	45.1	1182	904	46.3	1202	958	47.3	1240	1041	48.7			
3500 [1652]	986	492	38.0	1034	569	39.9	1062	629	41.1	1090	690	42.2	1131	767	43.9	1143	809	44.6	1177	882	46.0	1208	954	47.3	1224	1005	48.2	1260	1087	49.5			
3600 [1699]	1014	529	39.1	1059	605	40.9	1085	664	42.0	1115	730	43.2	1152	804	44.8	1165	851	45.5	1195	921	46.8	1228	996	48.2	1245	1050	49.0	1277	1129	50.2			
3700 [1746]	1042	569	40.2	1082	639	41.8	1107	699	42.9	1135	764	44.0	1175	846	45.8	1179	882	46.2	1218	964	47.7	1249	1040	49.0	1267	1099	49.9	1293	1169	50.9			
3800 [1793]	1066	602	41.1	1105	674	42.7	1131	739	43.9	1158	805	45.0	1196	887	46.7	1203	926	47.2	1242	1015	48.7	1268	1084	49.8	1287	1147	50.7	1312	1218	51.7			
3900 [1840]	1094	644	42.2	1129	712	43.7	1158	784	45.0	1181	848	46.0	1218	930	47.6	1223	969	48.0	1265	1065	49.6	1286	1128	50.5	1309	1196	51.5	1333	1269	52.4			
4000 [1888]	1117	679	43.1	1156	760	44.8	1176	819	45.8	1205	894	47.0	1239	975	48.5	1248	1021	49.0	1284	1105	50.3	1309	1179	51.4	1328	1242	52.2	1353	1320	53.1			
4100 [1935]	1144	724	44.2	1182	809	45.9	1203	870	46.9	1229	939	48.0	1261	1019	49.3	1269	1065	49.9	1305	1153	51.1	1330	1229	52.1	1351	1300	53.0	1373	1372	53.7			
4200 [1982]	1162	757	45.0	1204	846	46.8	1225	910	47.8	1255	990	49.0	1283	1067	50.2	1290	1113	50.7	1329	1208	52.0	1352	1282	52.9	1370	1349	53.6	1396	1430	54.4			
4300 [2029]	1183	798	46.0	1229	895	47.9	1250	960	48.8	1277	1037	49.9	1304	1111	51.0	1311	1160	51.5	1346	1249	52.6	1372	1334	53.5	1389	1398	54.2	1415	1483	55.0			
4400 [2076]	1207	838	47.0	1253	939	48.8	1273	1006	49.7	1300	1087	50.8	1326	1160	51.8	1333	1212	52.3	1368	1304	53.3	1396	1395	54.2	1419	1473	55.1	1437	1544	55.8			
4500 [2123]	1236	893	48.2	1269	977	49.5	1302	1067	50.8	1324	1137	51.7	1349	1216	52.6	1357	1269	53.1	1391	1364	54.0	1416	1445	54.9	1441	1530	55.8	1454	1597	56.6			
4600 [2171]	1259	936	49.1	1291	1022	50.4	1326	1118	51.7	1348	1193	52.5	1369	1268	53.3	1379	1321	53.8	1405	1404	54.6	1436	1505	55.6	1466	1601	56.9	1480	1669	57.8			
4700 [2218]	1290	1001	50.3	1316	1076	51.4	1347	1167	52.4	1376	1260	53.4	1391	1323	54.0	1402	1379	54.5	1426	1461	55.3	1461	1572	56.7	1485	1659	57.9	1501	1736	59.0			
4800 [2265]	1313	1047	51.2	1341	1133	52.3	1373	1226	53.3	1396	1310	54.1	1415	1383	54.8	1422	1434	55.2	1448	1522	56.2	1483	1637	57.8	1507	1725	59.1	1525	1806	60.3			

Air Flow	Model RHPDYC0120 Voltage 460 — 3 phase 60 Hz																																
	External Static Pressure—Inches of Water [kPa]																																
	1.1 [.27]			1.2 [.30]			1.3 [.32]			1.4 [.35]			1.5 [.37]			1.6 [.40]			1.7 [.42]			1.8 [.45]			1.9 [.47]			2.0 [.50]					
	RPM	W	%	RPM	W	%	RPM	W	%	RPM	W	%	RPM	W	%	RPM	W	%	RPM	W	%	RPM	W	%	RPM	W	%	RPM	W	%	RPM	W	%
3200 [1510]	1231	1026	48.4	1249	1076	49.2	1275	1142	50.2	1303	1212	51.3	1330	1284	52.3	1349	1341	53.0	1379	1423	53.9	1399	1483	54.5	1426	1566	55.5	1444	1636	56.3			
3300 [1557]	1252	1072	49.2	1265	1115	49.9	1293	1187	50.9	1322	1262	52.0	1347	1330	52.9	1367	1395	53.6	1399	1482	54.5	1419	1547	55.2	1442	1630	56.2	1462	1697	57.1			
3400 [1604]	1268	1113	49.9	1287	1167	50.7	1311	1233	51.6	1339	1308	52.6	1366	1384	53.5	1387	1450	54.2	1414	1527	55.0	1434	1593	55.7	1460	1689	57.0	1481	1764	58.1			
3500 [1652]	1289	1163	50.7	1305	1213	51.4	1330	1286	52.3	1358	1358	53.2	1383	1430	54.0	1405	1501	54.8	1431	1580	55.6	1453	1653	56.5	1482	1754	58.1	1499	1823	59.1			
3600 [1699]	1307	1208	51.4	1324	1264	52.1	1348	1333	52.9	1377	1413	53.8	1402	1486	54.6	1423	1553	55.3	1448	1633	56.3	1469	1708	57.3	1499	1815	59.1	1512	1875	59.9			
3700 [1746]	1327	1258	52.1	1344	1316	52.8	1367	1386	53.5	1393	1462	54.3	1420	1540	55.2	1441	1610	56.0	1464	1690	57.1	1486	1767	58.2	1521	1885	60.3	1529	1936	60.9			
3800 [1793]	1347	1308	52.8	1363	1367	53.4	1386	1439	54.1	1415	1525	55.0	1436	1592	55.8	1460	1671	56.9	1478	1742	57.9	1503	1824	59.2	1539	1948	61.3	1551	2007	62.1			
3900 [1840]	1369	1365	53.5	1385	1424	54.1	1405	1493	54.7	1434	1582	55.7	1456	1653	56.6	1478	1729	57.8	1494	1802	58.8	1522	1891	60.3	1557	1969	62.2	1567	2028	62.8			
4000 [1888]	1388	1414	54.1	1404	1479	54.7	1426	1554	55.4	1450	1634	56.4	1478	1722	57.7	1497	1797	58.9	1510	1854	59.7	1542	1965	61.5	1573	2034	63.0	1583	2091	63.6			
4100 [1935]	1409	1473	54.8	1424	1532	55.3	1446	1613	56.2	1469	1693	57.3	1496	1781	58.7	1514	1857	59.9	1528	1920	60.8	1561	1987	62.4	1590	2097	63.8	1603	2164	64.5			
4200 [1982]	1431	1532	55.5	1444	1591	56.1	1466	1673	57.1	1490	1761	58.4	1514	1846	59.8	1534	1925	61.1	1546	1988	61.9	1581	2064	63.4	1610	2173	64.7	1621	2232	65.3			
4300 [2029]	1451	1590	56.3	1467	1658	57.1	1488	1741	58.3	1509	1823	59.5	1534	1914	61.0	1557	1958	62.2	1561	2003	62.6	1597	2119	64.1	1627	2239	65.5	1642	2312	66.2			
4400 [2076]	1470	1648	57.2	1487	1722	58.2	1508	1803	59.4	1528	1887	60.6	1554	1981	62.1	1577	2031	63.2	1583	2079	63.6	1620	2201	65.1	1646	2309	66.3	1660	2383	67.0			
4500 [2123]	1490	1712	58.3	1508	1790	59.4	1531	1877	60.7	1548	1957	61.8	1575	2009	63.0	1597	2102	64.1	1603	2152	64.5	1637	2272	65.9	1667	2391	67.2	1679	2458	67.8			
4600 [2171]	1507	1771	59.3	1528	1853	60.5	1547	1935	61.7	1570	1988	62.8	1597	2088	64.0	1615	2171	64.9	1623	2227	65.4	1651	2332	66.6	1686	2473	68.1	1701	2550	68.8			
4700 [2218]	1524	1825	60.3	1549	1921	61.7	1569	1966	62.7	1590	2057	63.7	1617	2162	64.9	1638	2256	65.9	1643	2304	66.3	1667	2405	67.4	1708	2558	69.0	1721	2635	69.6			
4800 [2265]	1545	1894	61.5	1567	1947	62.6	1592	2043	63.7	1610	2128	64.6	1637	2235	65.8	1657	2326	66.7	1662	2379	67.1	1684	2472	68.1	1727	2642	69.8	1739	2712	70.3			

- NOTES:** 1. Factory airflow setting of VDC (%) at AHRI minimum External Static Pressure. Adjust VDC (%) value to achieve desire airflow.
2. Do not set outside range of VDC (%) values from the values shown in Table
3. Drive data is for Sideflow/Downflow with dry coil. Add component resistance (below) to determine total External Static Pressure

AIRFLOW PERFORMANCE — 10 TON — 60 Hz — 460V — SIDEFLOW (CONTINUED)

Airflow	AIRFLOW CORRECTION FACTORS*			COMPONENT AIRFLOW RESISTANCE					
				Wet Coil	Horizontal Economizer RA Damper Open	Concentric Diffuser RXRN-AEF3415 & Concentric Adapter RXMC-DD02 (Flush)	Concentric Diffuser RXRN-AED3415 & Concentric Adapter RXMC-DD02 (Drop)	Pressure Drop MERV 8	Pressure Drop MERV 13
CFM [L/s]	Total kBtu/h	Sensible kBtu/h	Power kW	Resistance — Inches of Water [kPa]					
3200 [1510]	0.96	0.91	0.98	0.07 [0.02]	0.31 [0.08]	0.74 [.18]	0.56 [.14]	0.100 [.02]	0.058 [.02]
3300 [1557]	0.97	0.92	0.99	0.07 [0.02]	0.36 [0.09]	0.79 [.20]	0.59 [.15]	0.104 [.03]	0.065 [.02]
3400 [1604]	0.97	0.93	0.99	0.07 [0.02]	0.42 [0.10]	0.84 [.21]	0.62 [.15]	0.108 [.03]	0.071 [.02]
3500 [1652]	0.98	0.94	0.99	0.08 [0.02]	0.47 [0.12]	0.90 [.22]	0.66 [.16]	0.112 [.03]	0.077 [.02]
3600 [1699]	0.98	0.95	0.99	0.08 [0.02]	0.52 [0.13]	0.95 [.24]	0.69 [.17]	0.116 [.03]	0.083 [.02]
3700 [1746]	0.99	0.97	1.00	0.09 [0.02]	0.58 [0.14]	1.00 [.25]	0.73 [.18]	0.120 [.03]	0.089 [.02]
3800 [1793]	0.99	0.98	1.00	0.09 [0.02]	0.63 [0.16]	1.04 [.26]	0.76 [.19]	0.124 [.03]	0.095 [.02]
3900 [1840]	1.00	0.99	1.00	0.09 [0.02]	0.68 [0.17]	1.09 [.27]	0.80 [.20]	0.128 [.03]	0.102 [.02]
4000 [1888]	1.00	1.00	1.01	0.10 [0.02]	0.73 [0.18]	1.13 [.28]	0.84 [.21]	0.132 [.03]	0.108 [.03]
4100 [1935]	1.00	1.01	1.01	0.10 [0.03]	0.78 [0.19]	1.19 [.30]	0.88 [.22]	0.136 [.03]	0.114 [.03]
4200 [1982]	1.01	1.02	1.01	0.11 [0.03]	0.83 [0.21]	1.24 [.31]	0.92 [.23]	0.140 [.03]	0.120 [.03]
4300 [2029]	1.01	1.03	1.01	0.11 [0.03]	0.88 [0.22]	1.31 [.33]	0.97 [.24]	0.144 [.03]	0.126 [.03]
4400 [2076]	1.02	1.05	1.02	0.12 [0.03]	0.93 [0.23]	1.37 [.34]	1.02 [.25]	0.148 [.04]	0.132 [.03]
4500 [2123]	1.02	1.06	1.02	0.13 [0.03]	0.98 [0.24]	1.43 [.35]	1.07 [.27]	0.152 [.04]	0.138 [.03]
4600 [2171]	1.03	1.07	1.02	0.13 [0.03]	1.03 [0.26]	1.48 [.37]	1.11 [.28]	0.156 [.04]	0.145 [.04]
4700 [2218]	1.03	1.08	1.03	0.14 [0.03]	1.07 [0.27]	1.54 [.38]	1.15 [.29]	0.160 [.04]	0.151 [.04]
4800 [2265]	1.04	1.09	1.03	0.14 [0.04]	1.12 [0.28]	1.59 [.40]	1.19 [.30]	0.164 [.04]	0.157 [.04]

*Multiply correction factor times gross performance data resulting sensible capacity cannot exceed total capacity.

[] Designates Metric Conversions

ELECTRICAL DATA – RHPDYC SERIES

		078ACK	078ADK	090ACK	090ADK	102ACK	102ADK	120ACK	120ADK
Unit Information	Unit Operating Voltage Range	187-253	414-506	187-253	414-506	187-253	414-506	187-253	414-506
	Volts	208/230	460	208/230	460	208/230	460	208/230	460
	Phase	3	3	3	3	3	3	3	3
	Hz	60	60	60	60	60	60	60	60
	Minimum Circuit Ampacity	46/46	25	48/48	26	50/50	25	51/51	25
	Minimum Circuit Ampacity with Power Exhaust	52/52	28	53/53	28	56/56	28	57/57	28
	Minimum Overcurrent Protection Device Size	50/50	30	60/60	30	60/60	30	60/60	30
	Minimum Overcurrent Protection Device Size with Power Exhaust	60/60	30	60/60	30	60/60	30	70/70	30
	Maximum Overcurrent Protection Device Size	50/50	30	60/60	30	60/60	30	60/60	30
	Maximum Overcurrent Protection Device Size with Power Exhaust	60/60	30	60/60	30	60/60	30	70/70	30
Compressor Motor	No.	2	2	2	2	2	2	2	2
	Volts	208/230	460	208/230	460	208/230	460	208/230	460
	Phase	3	3	3	3	3	3	3	3
	Amps (RLA), Comp. 1	11.5	6.5	13.5	6.4	14.0	6.3	14.3	6.3
	Amps (LRA), Comp. 1	114.0	56.0	120.4	50.0	150.0	58.0	150.0	58.0
	Amps (RLA), Comp. 2	12.2	5.8	11.5	6.5	13.5	6.4	13.5	6.4
	Amps (LRA), Comp. 2	102.8	50.0	114.0	56.0	120.4	50.0	120.4	50.0
Condenser Motor	No.	2	2	2	2	2	2	2	2
	Volts	208/230	460	208/230	460	208/230	460	208/230	460
	Phase	1	1	1	1	1	1	1	1
	HP	1/2	1/2	1/2	1/2	1/2	1/2	1/2	1/2
	Amps (FLA, each)	3.8	2.3	3.8	2.3	3.8	2.3	4.2	2.3
Evaporator Fan	No.	1	1	1	1	1	1	1	1
	Volts	208/230	460	208/230	460	208/230	460	208/230	460
	Phase	3	3	3	3	3	3	3	3
	HP	5	5	5	5	5	5	5	5
	Amps (FLA, each)	11.3	6.0	11.3	6.0	11.3	6.0	11.3	6.0

208/230V THREE PHASE, 60 Hz, AUXILIARY ELECTRIC HEATER KITS CHARACTERISTICS AND APPLICATION

Single Power Supply For Both Unit and Heater Kit

Unit Model No. RHPDYC	Heater Kit			Heat Pump			Heater Kit			Heat Pump		
	Model No. RXJJ-	Rated Heater kW @ 208/230V	Heater Kit FLA	Unit Min. Ampacity @208/230V	Unit Min. Ampacity @208/230V W/Powered Exhaust	Max. Fuse or Ckt. Bkr. Size	Max. Fuse or Ckt. Bkr. Size W/Powered Exhaust	Heater Kit Min. Ckt. Ampacity	Max Fuse Size or Ckt. Bkr. Size	Min. Circuit Ampacity W/ Powered Exhaust	Air Cond. Max Fuse or Ckt. Bkt. Size	Air Cond. Max Fuse or Ckt. Bkt. Size W/ Powered Exhaust
078ACK	NONE	—	—	46/46	52/52	50/50	60/60	—	—	46/46	50/50	60/60
	ED10CP	7.4/9.9	20.6/23.8	72/76	77/81	80/80	80/90	26/30	30/30	46/46	52/52	60/60
	ED15CP	10.8/14.4	30.0/34.6	84/89	89/95	90/90	90/100	38/44	40/45	46/46	52/52	60/60
	ED20CP	14.8/19.8	41.2/47.6	98/106	103/111	100/110	110/125	52/60	60/60	46/46	52/52	60/60
	ED30CP	21.6/28.8	60.0/69.3	121/133	127/138	125/150	150/150	75/87	80/90	46/46	52/52	60/60
090ACK	ED40CP	29.7/39.6	82.4/95.2	149/165	155/171	150/175	175/175	103/119	110/125	46/46	52/52	60/60
	NONE	—	—	48/48	53/53	60/60	60/60	—	—	48/48	60/60	60/60
	ED10CP	7.4/9.9	20.6/23.8	74/78	79/83	80/80	80/90	26/30	30/30	48/48	53/53	60/60
	ED15CP	10.8/14.4	30.0/34.6	85/91	91/96	90/100	100/100	38/44	40/45	48/48	53/53	60/60
	ED20CP	14.8/19.8	41.2/47.6	99/107	105/113	100/110	110/125	52/60	60/60	48/48	53/53	60/60
102ACK	ED30CP	21.6/28.8	60.0/69.3	123/134	128/140	125/150	150/150	75/87	80/90	48/48	53/53	60/60
	ED40CP	29.7/39.6	82.4/95.2	151/167	156/172	175/175	175/175	103/119	110/125	48/48	53/53	60/60
	NONE	—	—	50/50	56/56	60/60	60/60	—	—	50/50	60/60	60/60
	ED10CP	7.4/9.9	20.6/23.8	76/80	82/86	80/80	90/90	26/30	30/30	50/50	56/56	60/60
	ED15CP	10.8/14.4	30.0/34.6	88/94	93/99	90/100	100/100	38/44	40/45	50/50	56/56	60/60
120ACK	ED20CP	14.8/19.8	41.2/47.6	102/110	107/115	110/110	110/125	52/60	60/60	50/50	56/56	60/60
	ED30CP	21.6/28.8	60.0/69.3	125/137	131/142	125/150	150/150	75/87	80/90	50/50	56/56	60/60
	ED40CP	29.7/39.6	82.4/95.2	153/169	159/175	175/175	175/175	103/119	110/125	50/50	56/56	60/60
	NONE	—	—	51/51	57/57	60/60	70/70	—	—	51/51	57/57	70/70
	ED10CP	7.4/9.9	20.6/23.8	77/81	83/87	80/90	90/90	26/30	30/30	51/51	57/57	70/70
120ACK	ED15CP	10.8/14.4	30.0/34.6	89/95	94/100	90/100	100/100	38/44	40/45	51/51	57/57	70/70
	ED20CP	14.8/19.8	41.2/47.6	103/111	108/116	110/125	110/125	52/60	60/60	51/51	57/57	70/70
	ED30CP	21.6/28.8	60.0/69.3	126/138	132/143	150/150	150/150	75/87	80/90	51/51	57/57	70/70
	ED40CP	29.7/39.6	82.4/95.2	154/170	160/176	175/175	175/200	103/119	110/125	51/51	57/57	70/70

460V THREE PHASE, 60 Hz, AUXILIARY ELECTRIC HEATER KITS CHARACTERISTICS AND APPLICATION

Single Power Supply For Both Unit and Heater Kit

Unit Model No. RHPDYC	Heater Kit			Heat Pump			Heater Kit			Heat Pump			
	Model No. RXJJ-	Rated Heater kW @ 460V	Heater Kit FLA	Unit Min. Ampacity @460V	Unit Min. Ampacity @460V W/Powered Exhaust	Max. Fuse or Ckt. Bkr. Size	Max. Fuse or Ckt. Bkr. Size W/Powered Exhaust	Heater Kit Min. Ckt. Ampacity	Max Fuse Size or. Ckt. Bkr Size	Min. Circuit Ampacity	Min. Circuit Ampacity W/Powered Exhaust	Air Cond. Max Fuse or Ckt. Bkt. Size	Air Cond. Max Fuse or Ckt. Bkt. Size W/ Powered Exhaust
078ADK	NONE	—	—	25	28	30/30	30/30	—	—	25	28	30/30	30/30
	ED10DNV	9.9	11.9	40	43	40/40	45/45	15	15	25	28	30/30	30/30
	ED15DNV	14.4	17.3	47	49	50/50	60/60	22	25	25	28	30/30	30/30
	ED20DNV	19.8	23.8	55	57	60/60	80/80	30	30	25	28	30/30	30/30
090ADK	ED30DNV	28.8	34.6	68	71	70/70	90/90	44	45	25	28	30/30	30/30
	ED40DNV	39.6	47.6	85	87	90/90	90/90	60	60	25	28	30/30	30/30
	NONE	—	—	26	28	30/30	30/30	—	—	26	28	30/30	30/30
	ED10DNV	9.9	11.9	40	43	40/40	45/45	15	15	26	28	30/30	30/30
102ADK	ED15DNV	14.4	17.3	47	50	50/50	60/60	22	25	26	28	30/30	30/30
	ED20DNV	19.8	23.8	55	58	60/60	80/80	30	30	26	28	30/30	30/30
	ED30DNV	28.8	34.6	69	72	70/70	90/90	44	45	26	28	30/30	30/30
	ED40DNV	39.6	47.6	85	88	90/90	90/90	60	60	26	28	30/30	30/30
120ADK	NONE	—	—	25	28	30/30	30/30	—	—	25	28	30/30	30/30
	ED10DNV	9.9	11.9	40	43	40/40	45/45	15	15	25	28	30/30	30/30
	ED15DNV	14.4	17.3	47	50	50/50	60/60	22	25	25	28	30/30	30/30
	ED20DNV	19.8	23.8	55	58	60/60	80/80	30	30	25	28	30/30	30/30
120ADK	ED30DNV	28.8	34.6	69	71	70/70	90/90	44	45	25	28	30/30	30/30
	ED40DNV	39.6	47.6	85	88	90/90	90/90	60	60	25	28	30/30	30/30
	NONE	—	—	25	28	30/30	30/30	—	—	25	28	30/30	30/30
	ED10DNV	9.9	11.9	40	43	40/40	45/45	15	15	25	28	30/30	30/30
120ADK	ED15DNV	14.4	17.3	47	50	50/50	60/60	22	25	25	28	30/30	30/30
	ED20DNV	19.8	23.8	55	58	60/60	80/80	30	30	25	28	30/30	30/30
	ED30DNV	28.8	34.6	69	71	70/70	90/90	44	45	25	28	30/30	30/30
	ED40DNV	39.6	47.6	85	88	90/90	90/90	60	60	25	28	30/30	30/30

A2L REFRIGERANT INSTALLATION SAFETY DATA

Model		RHPDYC078	RHPDYC090	RHPDYC102	RHPDYC120
Refrigerant Charge Weight (oz)		202	214	204	219
Minimum Circulation Qmin (CFM)		672	712	679	728
Altitude above Sea Level (ft)	Altitude Adjustment Factor	Minimum total space area, T _{Amin} (sq-ft)			
0	1.000	372	394	376	404
1000	1.025	382	404	385	414
2000	1.051	391	415	395	424
3000	1.078	401	425	405	435
4000	1.107	412	437	416	447
5000	1.138	424	449	428	459
6000	1.170	436	462	440	472
6500	1.187	442	468	446	479

UNIT DIMENSIONS—6.5 TON MODELS

TOP VIEW

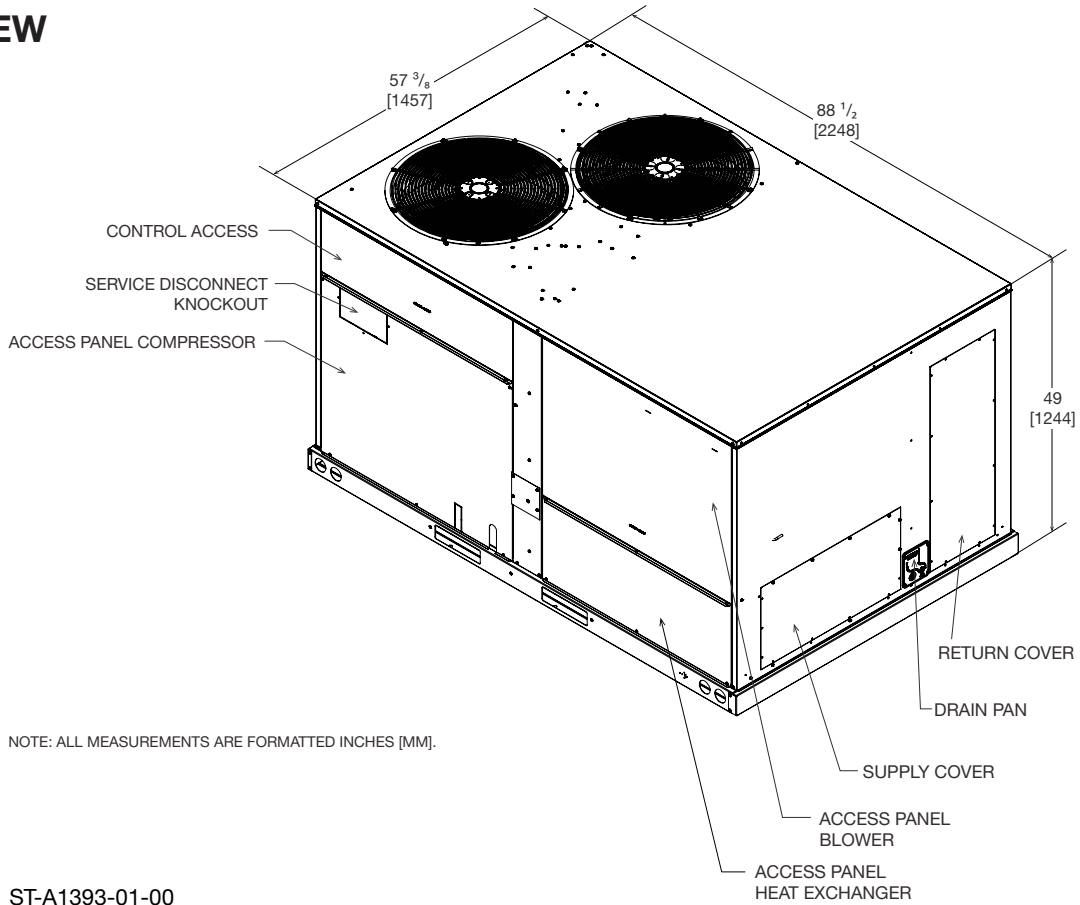

ST-A1393-01-00

BOTTOM VIEW

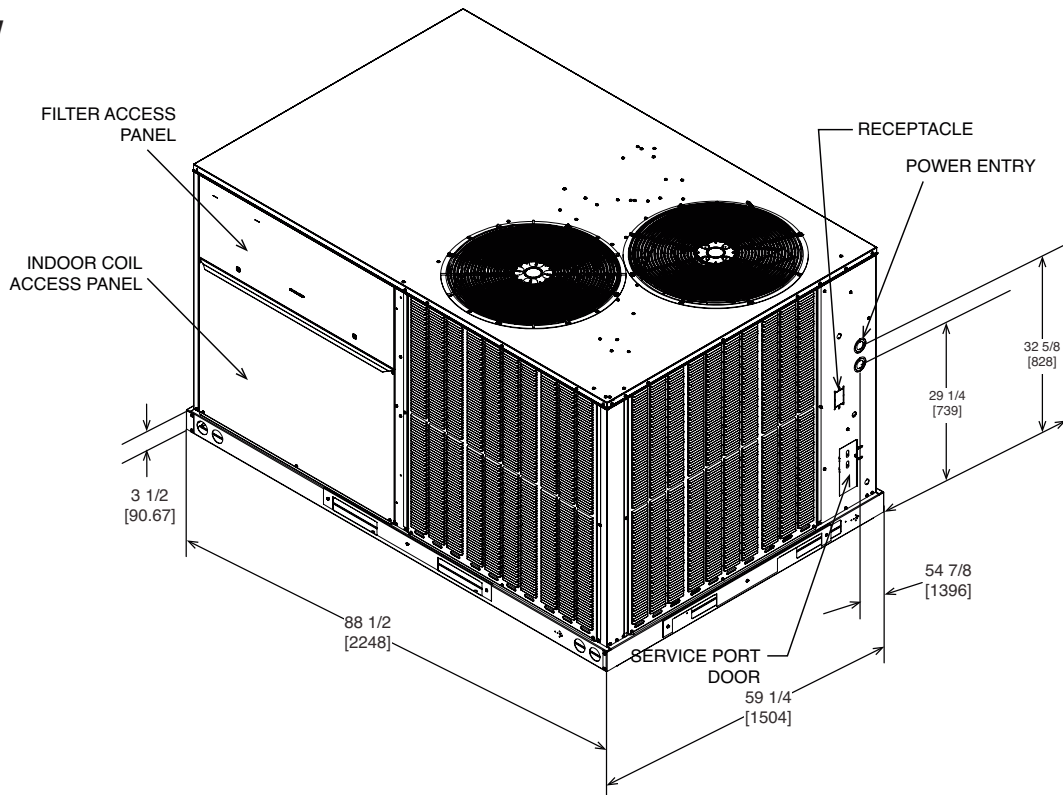

NOTE: ALL MEASUREMENTS ARE FORMATTED INCHES [MM].

ST-A1393-02-00

UNIT DIMENSIONS—7.5, 8.5 & 10 TON MODELS

TOP VIEW

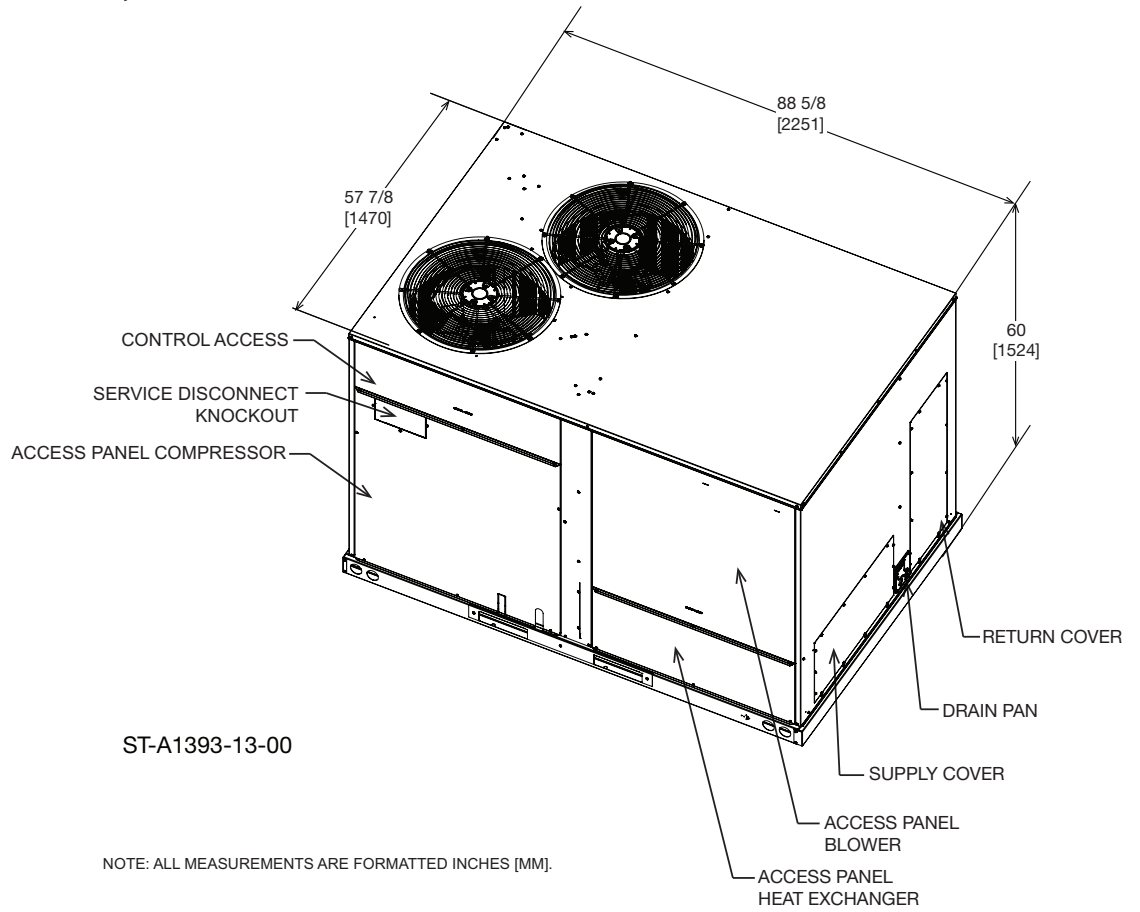

BOTTOM VIEW

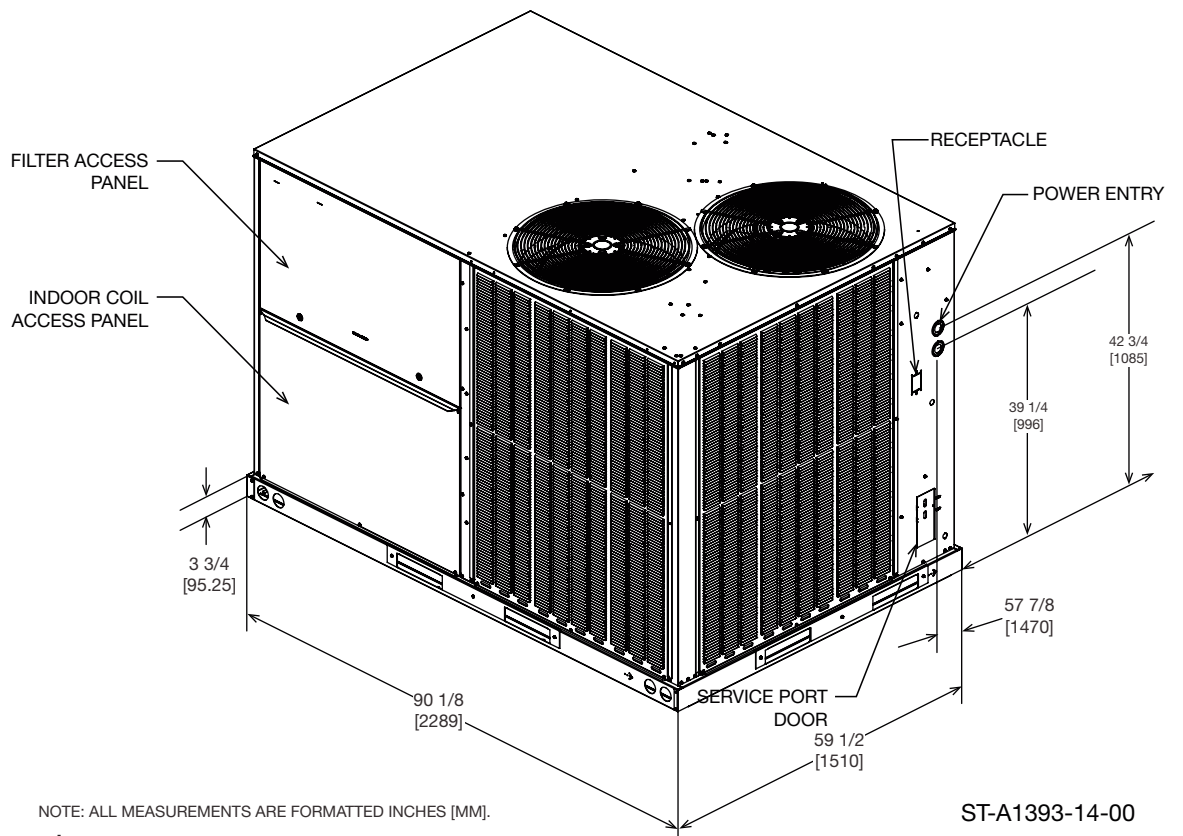

[] Designates Metric Conversions

SUPPLY AND RETURN DIMENSIONS FOR HORIZONTAL APPLICATIONS SIDE VIEW

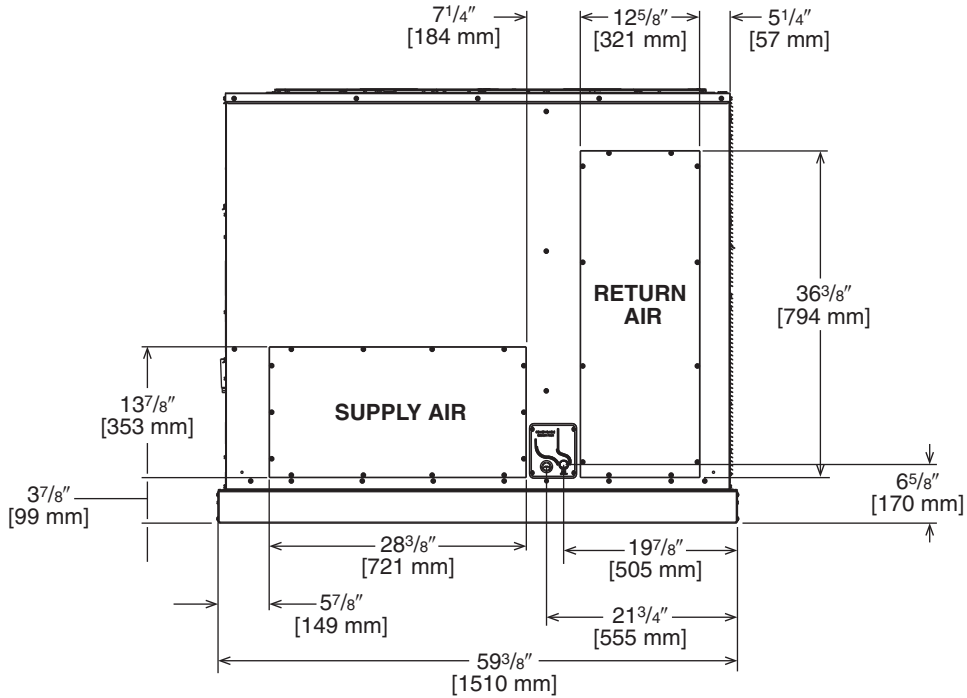
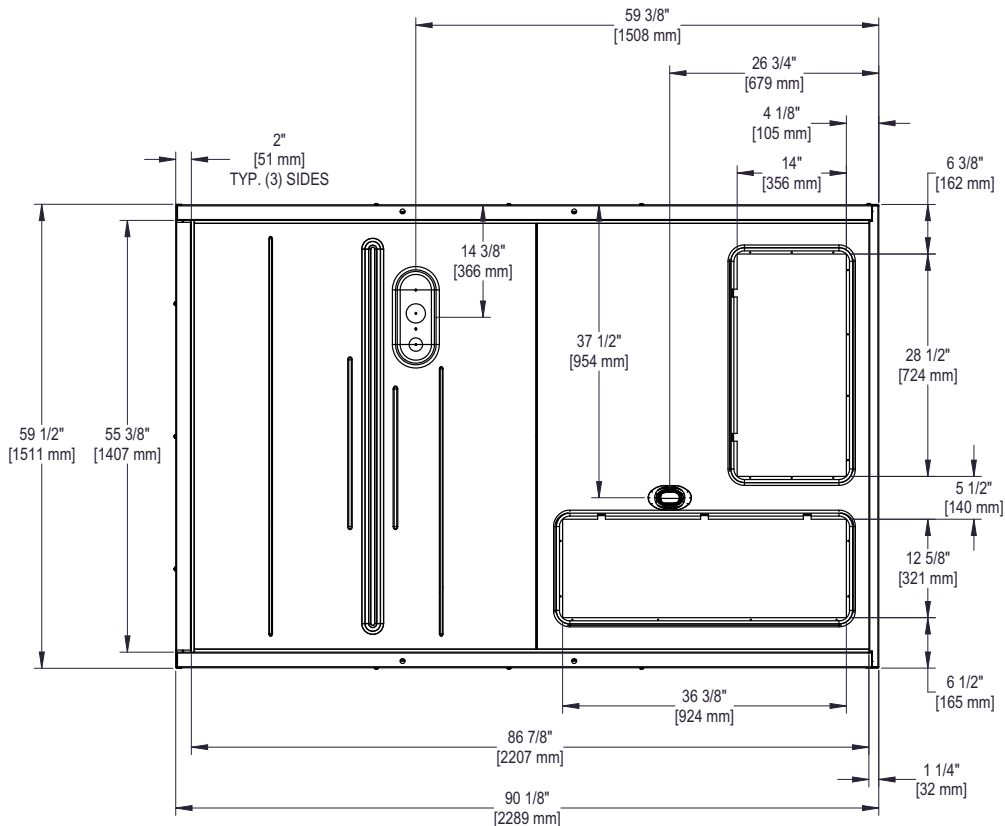

Illustration
00-71-3721A-TS

SUPPLY AND RETURN DIMENSIONS FOR DOWNFLOW APPLICATIONS (VIEW FROM BOTTOM UP)



ST-A1273-01_A

[] Designates Metric Conversions

WEIGHTS

Capacity Tons	Corner Weights by Percentage			
	A	B	C	D
6.5	7%	30%	15%	48%
7.5-10	22%	17%	29%	32%

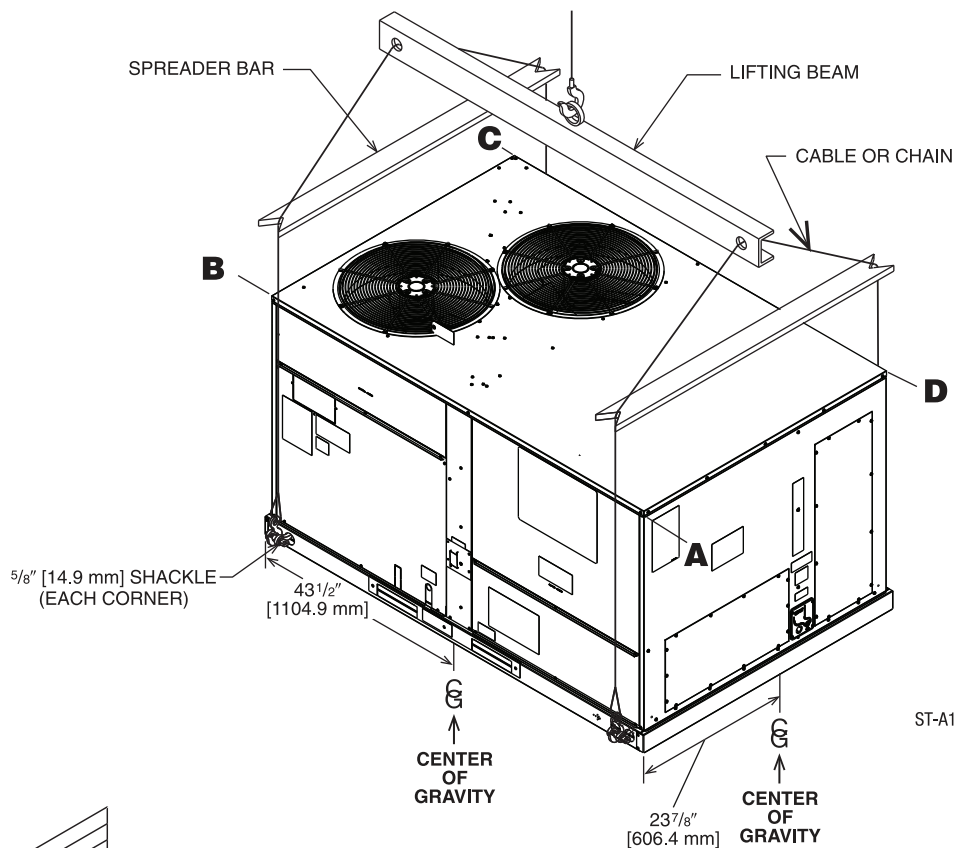

Illustration
ST-A1273-01_J-00

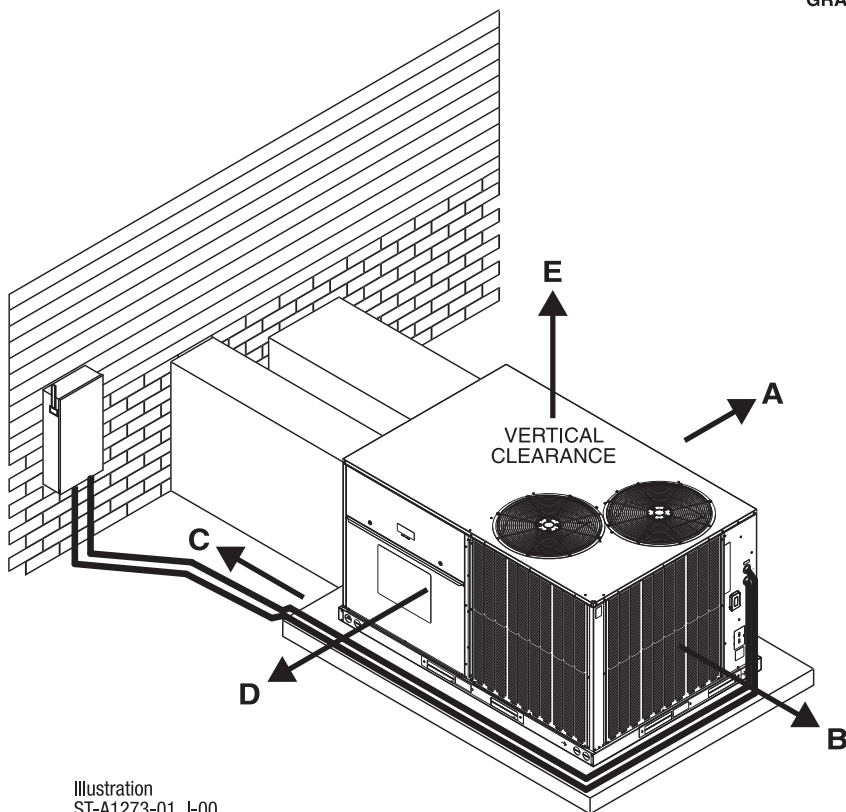

Illustration
ST-A1273-01_I-00

CLEARANCES

The following minimum clearances must be observed for proper unit performance and serviceability.

RECOMMENDED CLEARANCE In. [mm]	LOCATION
48 [1219]	A - FRONT
24 [609]	B - CONDENSER END
48 [1219] ①	C - DUCT END
24 [609] ②	D - FILTER SIDE
60 [1524]	E - ABOVE

① 18" [457 mm] MINIMUM IF DRAINPAN WILL NOT BE REMOVED.

② 48" [1219 MM] MINIMUM IF ECONOMIZER IS INSTALLED.

FIELD-INSTALLED ACCESSORY EQUIPMENT

Accessory	Model Number	Shipping Weight Lbs. [kg]	Installed Weight Lbs. [kg]	Factory Installation Available?
Non-DDC Economizer with Single Enthalpy (Downflow) <i>MicroMetl Economizer with Siemens Controls</i>	RXRD-11MDDAM3	86 [39.0]	57 [25.9]	Yes
Non-DDC Economizer with Single Enthalpy (Downflow) <i>RRS Economizer with Siemens Controller</i>	RXRD-51MDDAM3	86 [39.0]	57 [25.9]	No
Non-DDC Economizer with Single Enthalpy (Horizontal) <i>MicroMetl Economizer with Siemens Controls</i>	RXRD-11MDHAM3	84 [38.1]	55 [24.9]	No
Non-DDC Economizer with Single Enthalpy (Horizontal) <i>RRS Economizer with Siemens Controller</i>	RXRD-51MDHAM3	84 [38.1]	55 [24.9]	No
Power Exhaust (230V) Kit for Downflow Economizer <i>RRS</i>	RXRX-RDF01C	104 [47.2]	94 [42.6]	No
Power Exhaust (230V) Kit for Horizontal Economizer <i>RRS</i>	RXRX-RDF03C	104 [47.2]	94 [42.6]	No
Power Exhaust (230V) Kit, Convertible <i>MicroMetl</i>	RXRX-CDF01C	104 [47.2]	94 [42.6]	No
Power Exhaust (460V) Kit for Downflow Economizer <i>RRS</i>	RXRX-RDF01D	104 [47.2]	94 [42.6]	No
Power Exhaust (460V) Kit for Horizontal Economizer <i>RRS</i>	RXRX-RDF03D	104 [47.2]	94 [42.6]	No
Power Exhaust (460V) Kit, Convertible <i>MicroMetl</i>	RXRX-CDF01D	104 [47.2]	94 [42.6]	No
Convenience Outlet, Non-Powered	RXRX-BN01	2 [1.0]	1.5 [0.7]	Yes
Electric Heater Kit I 208/230V, 3ph, 10kW	RXJJ-ED10CP	30 [13.6]	27.5 [12.5]	Yes
Electric Heater Kit I 208/230V, 3ph, 15kW	RXJJ-ED15CP	32 [14.5]	29.5 [13.4]	Yes
Electric Heater Kit I 208/230V, 3ph, 20kW	RXJJ-ED20CP	34 [15.4]	31.5 [14.3]	Yes
Electric Heater Kit I 208/230V, 3ph, 30kW	RXJJ-ED30CP	37 [16.8]	34.5 [15.6]	Yes
Electric Heater Kit I 208/230V, 3ph, 40kW	RXJJ-ED40CP	40 [18.1]	37.5 [17.0]	Yes
Electric Heater Kit I 460V, 3ph, 10kW	RXJJ-ED10DNV	30 [13.6]	27.5 [12.5]	Yes
Electric Heater Kit I 460V, 3ph, 15kW	RXJJ-ED15DNV	32 [14.5]	29.5 [13.4]	Yes
Electric Heater Kit I 460V, 3ph, 20kW	RXJJ-ED20DNV	34 [15.4]	31.5 [14.3]	Yes
Electric Heater Kit I 460V, 3ph, 30kW	RXJJ-ED30DNV	37 [16.8]	34.5 [15.6]	Yes
Electric Heater Kit I 460V, 3ph, 40kW	RXJJ-ED40DNV	40 [18.1]	37.5 [17.0]	Yes
Fresh Air Damper, Manual	RXRF-ADA1	15 [6.8]	12 [5.4]	No
Fresh Air Damper, Motorized	RXRF-ADB1	38 [17.2]	31 [14.06]	No
Roofcurb Adapter	RXRX-DDCAE	235 [106.6]	215 [97.5]	No
Roofcurb, 14"	RXKG-DDD14	109 [49.4]	104 [47.2]	No
Roofcurb, 24"	RXKG-DDD24	145 [65.8]	140 [63.5]	No
Unfused Service Disconnect	RXRX-BP01	10 [4.5]	9 [4.1]	Yes
UV-C Light Kit 208/230V	RXRX-UVC34D	8 [3.6]	6 [2.7]	No
UV-C Light Kit Transformer 460V/575V	RXRX-UVCTD	12 [5.4]	11 [5.0]	No
Concentric Adapter 6.5, 7.5 & 8.5 Ton Drop	RXMC-DD01	40 [18.1]	34 [15.4]	No
Concentric Adapter 10 Ton Drop	RXMC-DD02	75 [34.0]	65 [29.5]	No
Concentric Diffuser 6.5, 7.5 & 8.5 Ton Drop	RXRN-AED2000	35 [15.9]	30 [13.6]	No
Concentric Diffuser 10 Ton Drop	RXRN-AED3415	170 [77.1]	160 [72.6]	No
Concentric Diffuser 6.5, 7.5 & 8.5 Ton Flush	RXRN-AEF2000	30 [13.6]	25 [11.3]	No
Concentric Diffuser 10 Ton Flush	RXRN-AEF3415	140 [113.4]	130 [59.0]	No
MERV 8 Filter 6.5 Ton	RXMF-M08A22020	2 [0.9]	1 [0.45]	No
MERV 8 Filter 7.5, 8.5 & 10 Ton	RXMF-M08A22520	2 [0.9]	1 [0.45]	No
MERV 13 Filter 6.5 Ton	RXMF-M13A22020	2 [0.9]	1 [0.45]	No
MERV 13 Filter 7.5, 8.5 & 10 Ton	RXMF-M13A22520	2 [0.9]	1 [0.45]	No
Outdoor Coil Louver Kit - 6.5 Ton	RXRX-ADD04A	52 [23.6]	47 [21.3]	Yes
Outdoor Coil Louver Kit - 7.5, 8.5 & 10 Ton	RXRX-ADD04B	43 [19.5]	39 [17.7]	Yes

[] Designates Metric Conversions

FIELD-INSTALLED ACCESSORY EQUIPMENT (CONTINUED)

Accessory	Model Number	Shipping Weight Lbs. [kg]	Installed Weight Lbs. [kg]	Factory Installation Available?
Single Point Wiring Kit 208/230V, 60A, 6.5 Ton	RXJX-AC0605	26 [11.8]	28 [12.7]	No
Single Point Wiring Kit 208/230V, 80A, 6.5 Ton	RXJX-AC0805	26 [11.8]	28 [12.7]	No
Single Point Wiring Kit 460V, 30A, 6.5 Ton	RXJX-AD0305	25 [11.3]	27 [12.2]	No
Single Point Wiring Kit 460V, 60A, 6.5 Ton	RXJX-AD0605	25 [11.3]	27 [12.2]	No
Single Point Wiring Kit 208/230V, 70A, 10 Ton	RXJX-AC0709	26 [11.8]	28 [12.7]	No
Single Point Wiring Kit 208/230V, 90A, 7.5, 8.5 & 10 Ton	RXJX-AC0909	26 [11.8]	28 [12.7]	No
Single Point Wiring Kit 460V, 40A, 7.5, 8.5 & 10 Ton	RXJX-AD0409	25 [11.3]	27 [12.2]	No
Single Point Wiring Kit 460V, 60A, 7.5, 8.5 & 10 Ton	RXJX-AD0609	25 [11.3]	27 [12.2]	No
Dual Enthalpy, Temperature and Humidity Sensor (<i>for Siemens</i>)	PD555460	1 [0.5]	1 [0.5]	No
Low-Ambient Control Kit	RXRZ-A07	4 [1.8]	3 [1.4]	Yes
Sensor, Carbon Dioxide (Wall Mount)	RXRX-AR02	3 [1.4]	2 [1.0]	No
Smoke Detector Kit, Return	RXRX-BS03	5 [2.7]	3.5 [1.6]	No
Smoke Detector Kit, Return/Supply	RXRX-BS04	7 [3.2]	5 [2.7]	No

[] Designates Metric Conversions

NON-DDC ECONOMIZER WITH SINGLE ENTHALPY (DOWNFLOW) MICROMETL ECONOMIZER WITH SIEMENS CONTROLS

Factory or Field-Installed

RXRD-11MDDAM3

PD555460—Dual Enthalpy, Temperature and Humidity Sensor (for Siemens Controller)

RRX-AR02—Sensor, Carbon Dioxide (Wall Mount)

- Features **Siemens** Controls
- Available Factory-Installed or Field Accessory
- Gear Driven Direct Drive Actuator
- Fully Modulating (0-100%)
- Ultra Low Leak Dampers meet California Title 24 requirements and ASHRAE 90.1 2022
- Slip-In Design for Easy Installation
- Standard Barometric Relief Damper
- Single Enthalpy with Dual Enthalpy Upgrade Kit Available
- CO₂ Input Sensor Option
- Field Assembled Hood Ships with Economizer
- Economizer Ships Complete for Downflow Duct Application
- Field-Installed Power Exhaust Option
- Prewired for Smoke Detector
- If connected to a Building Automation System (BAS), all economizer functions can be viewed on the (BAS) or 16 x 2 LCD screen
- If connected to thermostat, all economizer functions can be viewed on 16 x 2 LCD screen

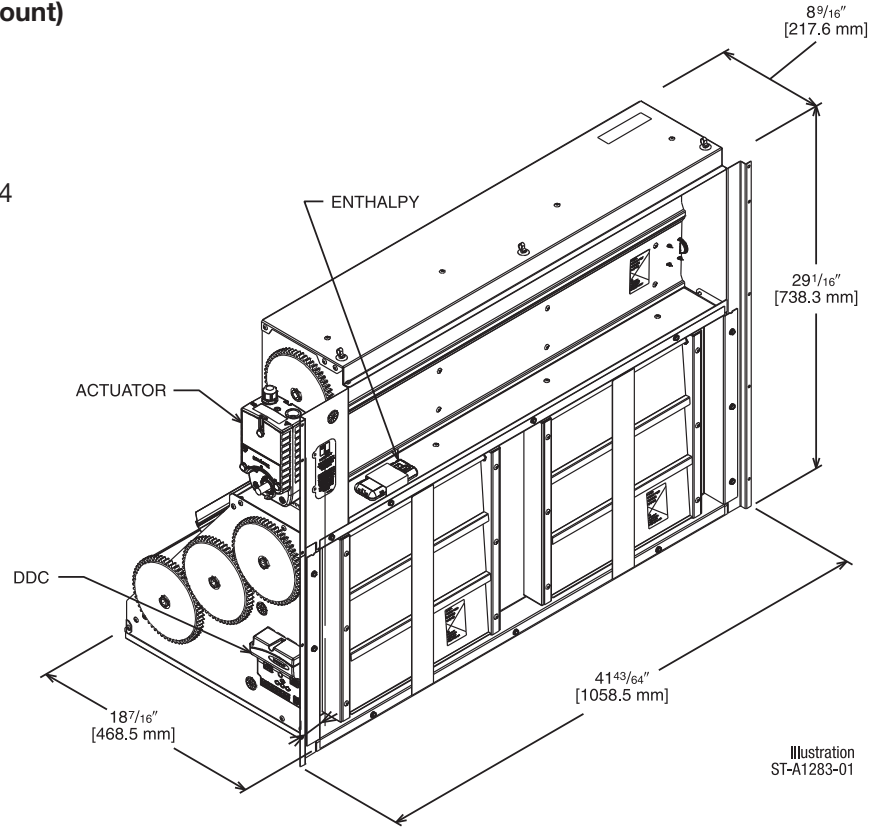

Illustration
ST-A1283-01

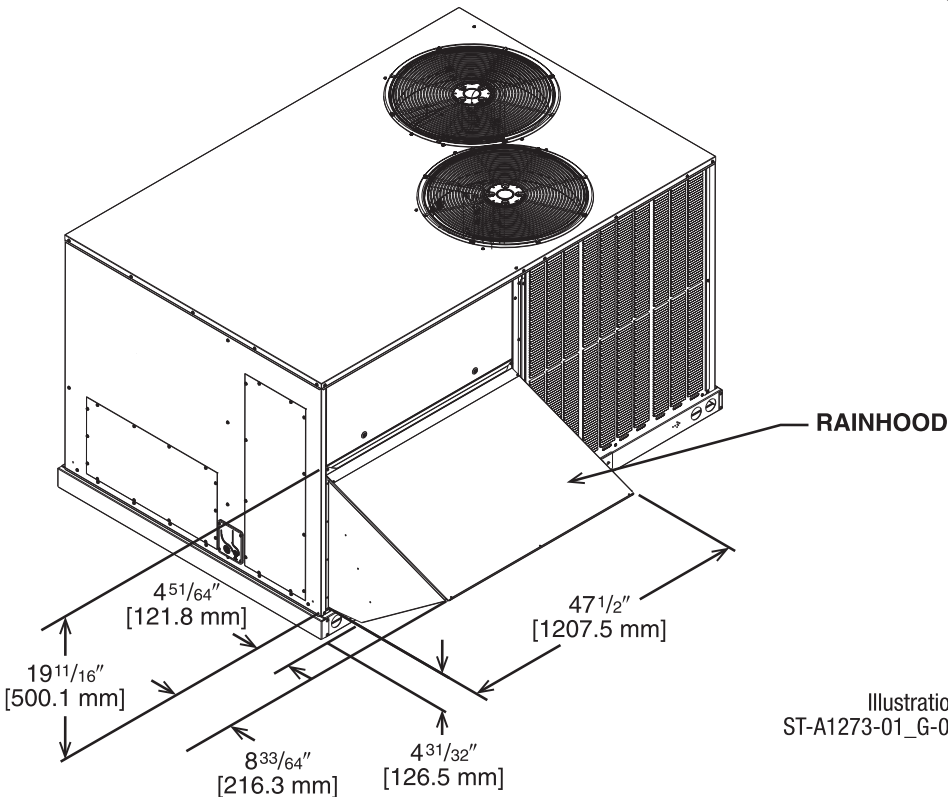

Illustration
ST-A1273-01_G-00

[] Designates Metric Conversions

NON-DDC ECONOMIZER WITH SINGLE ENTHALPY (DOWNFLOW) RRS ECONOMIZER WITH SIEMENS CONTROLLER

Field-Installed Only

RXRD-51MDDAM3

PD555460—Dual Enthalpy, Temperature and Humidity Sensor (for Siemens Controller)

RXXR-AR02—Sensor, Carbon Dioxide (Wall Mount)

These ultra-low leak economizer dampers meet the following minimum construction standards:

1. Frame shall be 14 to 24 gauge galvanized steel channel.
2. Damper blades are galvanized steel airfoil shaped, double skin construction of 14 gauge [2.0] equivalent thickness, 6" [152 mm] wide. Parallel action.
3. Blade edge seals shall be Ruskiprene™ type or equivalent suitable for -72°F [-60°C] to +275°F [+135°C] mechanically locked into the blade edge. Adhesive or clip-on type seals are unacceptable.
4. Jamb seals shall be flexible metal, compression type to prevent leakage between blade end and damper frame. Blade end overlapping frame is unacceptable.
5. Bearings shall be stainless steel or nylon bushing.
6. Axles shall be hexagonal positively locked into the damper blade.
7. Drive mechanism shall be concealed out of airstream to reduce pressure drop and noise.
8. Economizer damper is tested and rated based upon AMCA® Publication 500-D.
9. Controls feature the Siemens controller with Siemens 24V actuator. Controls capable of Economizer Fault Detection and Diagnostics for code compliance.
10. Damper shall meet the leakage requirements of the International Energy Conservation Code by leaking less than 3 CFM/sq. ft. at 1" of static pressure and shall be AMCA licensed as a class 1A damper. Complies with reliability and performance requirements as specified by the California Energy Commission's Title 24 Standard and ASHRAE 90.1 2022. Economizer dampers shall be Ruskin Rooftop Systems ECD60 model.

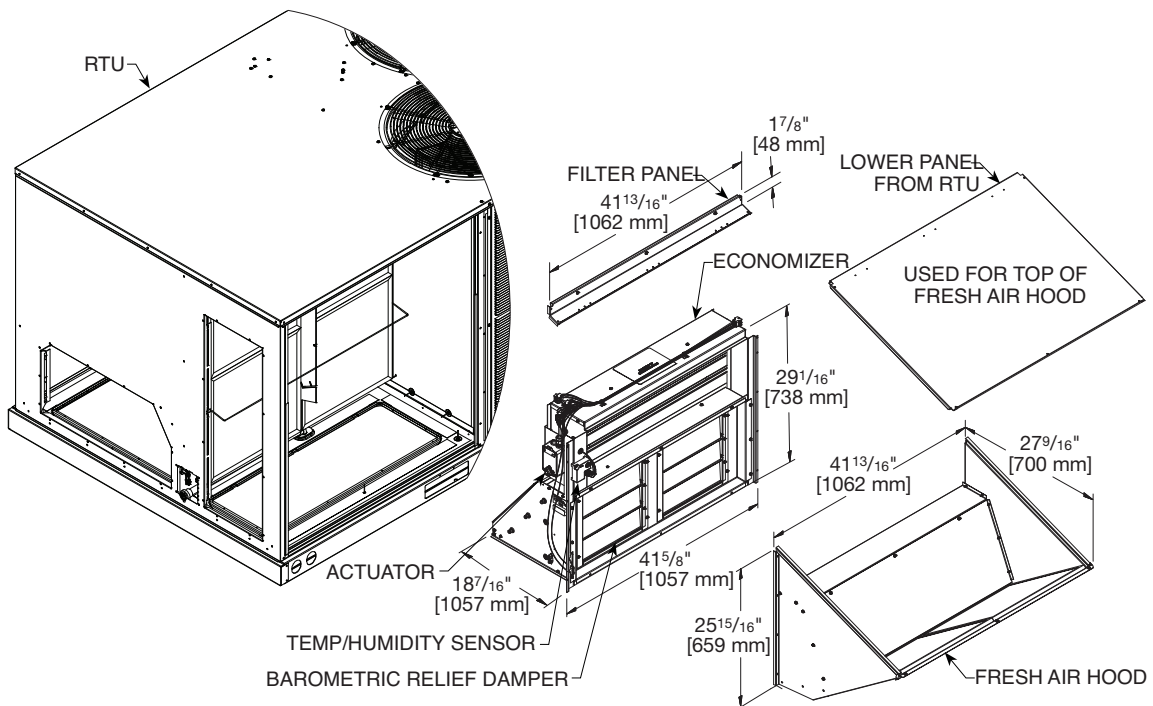

[] Designates Metric Conversions

NON-DDC ECONOMIZER WITH SINGLE ENTHALPY (HORIZONTAL) MICROMETL ECONOMIZER WITH SIEMENS CONTROLS

Field-Installed Only

RXRD-11MDHAM3

PD555460—Dual Enthalpy, Temperature and Humidity Sensor (for Siemens Controller)

RXRX-AR02—Sensor, Carbon Dioxide (Wall Mount)

- Features **Siemens** Controls
- Gear Driven Direct Drive Actuator
- Fully Modulating (0-100%)
- Low Leakage Dampers
- Slip-In Design for Easy Installation
- Standard Barometric Relief Damper
- Single Enthalpy with Dual Enthalpy Upgrade Kit Available
- CO₂ Input Sensor Option
- Field Assembled Hood Ships with Economizer
- Economizer Ships Complete for Horizontal Duct Application
- Field-Installed Power Exhaust Option
- If connected to a Building Automation System (BAS), all economizer functions can be viewed on the (BAS) or 16 x 2 LCD screen
- If connected to thermostat, all economizer functions can be viewed on 16 x 2 LCD screen

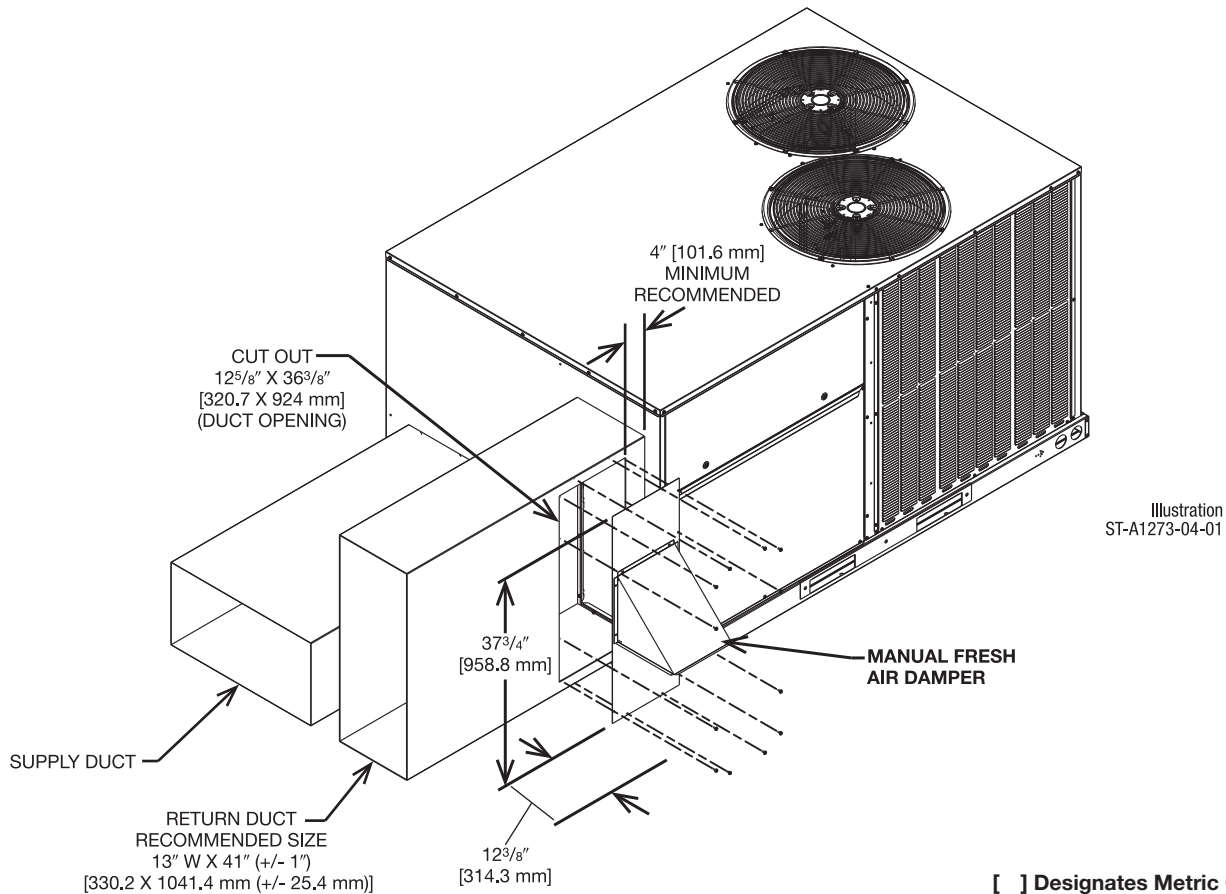
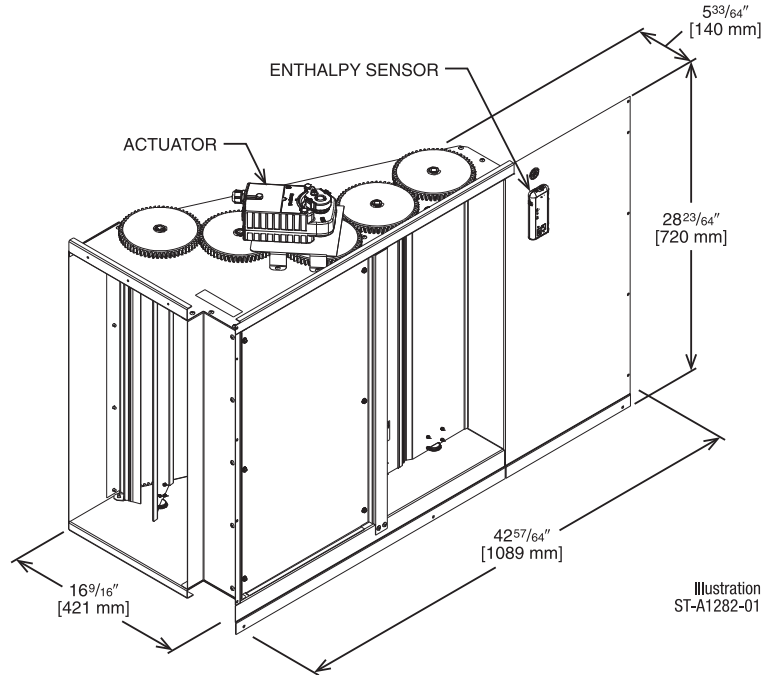

[] Designates Metric Conversions

NON-DDC ECONOMIZER W/SINGLE ENTHALPY (HORIZONTAL) RRS ECONOMIZER WITH SIEMENS CONTROLLER

Field-Installed Only

RXRD-51MDHAM3

PD555460—Dual Enthalpy, Temperature and Humidity Sensor (for Siemens Controller)

RXRX-AR02—Sensor, Carbon Dioxide (Wall Mount)

These ultra-low leak economizer dampers meet the following minimum construction standards:

1. Frame shall be 14 to 24 gauge galvanized steel channel.
2. Damper blades are galvanized steel airfoil shaped, double skin construction of 14 gauge [2.0] equivalent thickness, 6" [152 mm] wide. Parallel action.
3. Blade edge seals shall be Ruskiprene™ type or equivalent suitable for -72°F [-60°C] to +275°F [+135°C] mechanically locked into the blade edge. Adhesive or clip-on type seals are unacceptable.
4. Jamb seals shall be flexible metal, compression type to prevent leakage between blade end and damper frame. Blade end overlapping frame is unacceptable.
5. Bearings shall be stainless steel or nylon bushing.
6. Axles shall be hexagonal positively locked into the damper blade.
7. Drive mechanism shall be concealed out of airstream to reduce pressure drop and noise.
8. Economizer damper is tested and rated based upon AMCA Publication 500-D.
9. Controls feature the Siemens controller with Siemens 24V actuator. Controls capable of Economizer Fault Detection and Diagnostics for code compliance.
10. Damper shall meet the leakage requirements of the International Energy Conservation Code by leaking less than 3 CFM/sq. ft. at 1" of static pressure and shall be AMCA licensed as a class 1A damper. Complies with reliability and performance requirements as specified by the California Energy Commission's Title 24 Standard and ASHRAE 90.1 2022. Economizer dampers shall be Ruskin Rooftop Systems ECD60 model.

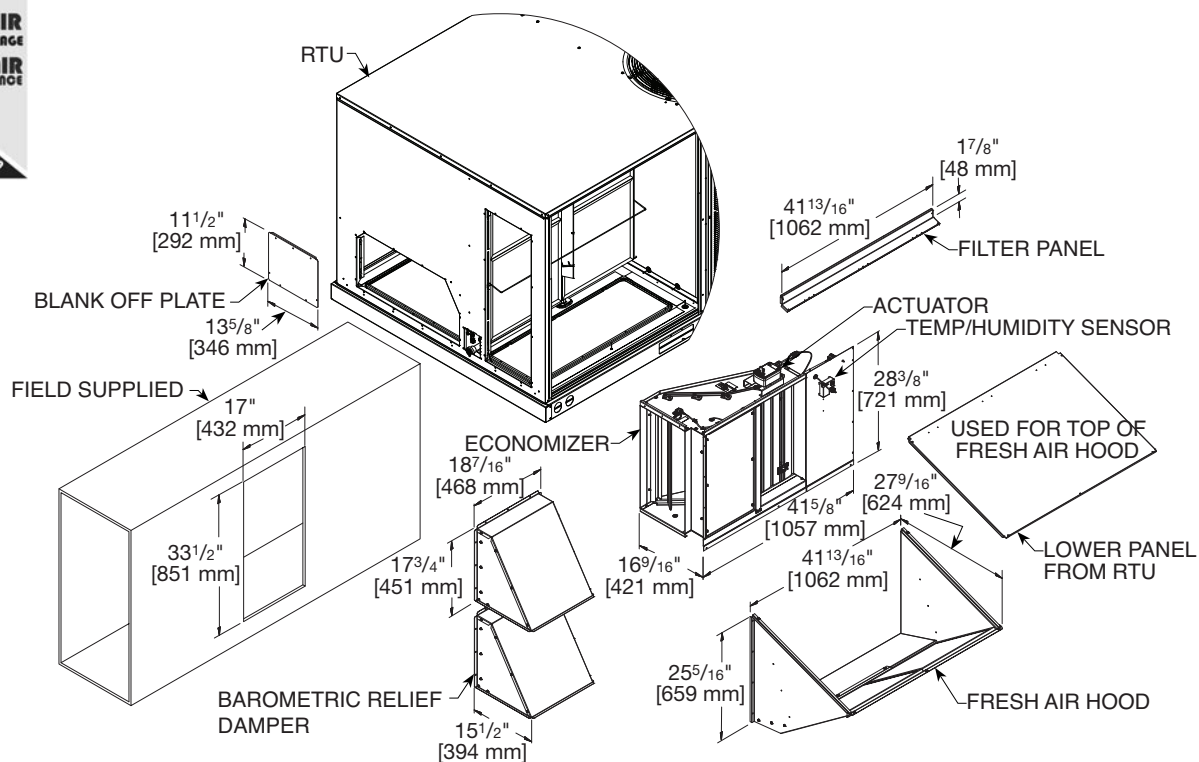

[] Designates Metric Conversions

POWER EXHAUST KIT FOR DOWNFLOW ECONOMIZER

RXXR-RDF01*

*Voltage Code: C or D

- Shipped completely assembled
- All wiring from control box to economizer is supplied
- Color coordinated with the unit
- Fully insulated with 1" 1.5 lb. fiberglass insulation
- Motors are factory wired and tested
- When using this power exhaust system, clearance between the bottom of the unit and finished roof deck should be a minimum of 10 inches. Some applications may require a taller roof curb for proper installation
- **Economizer Sold Separately**

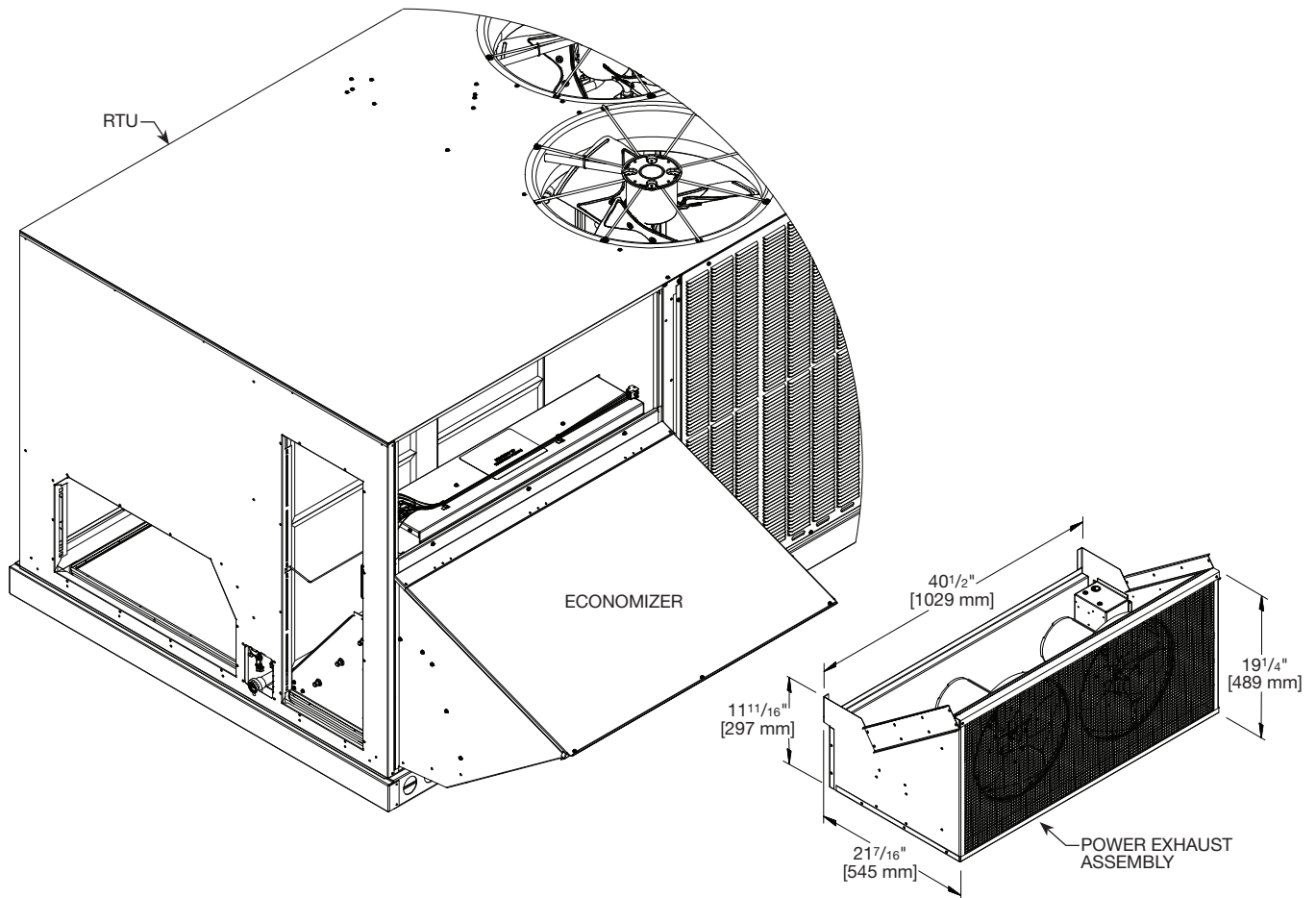

MODEL NO.	VOLT	PHASE	MOTOR				UNIT				@ 0.1 CFM
			HP	RPM	LRA	QTY.	CIR. QTY.	FLA	MCA	FUSE SIZE	
RXXR-RDF01C	208/230	1	1/2	1625	5.86	2	1	5.40	6.75	8	4013
RXXR-RDF01D	460				3.33			2.68	3.35	4	

[] Designates Metric Conversions

POWER EXHAUST KIT FOR HORIZONTAL ECONOMIZER

RXXR-RDF03*

*Voltage Code: C or D

- Shipped completely assembled
- All wiring from control box to economizer is supplied
- Color coordinated with the unit
- Fully insulated with 1" 1.5 lb. fiberglass insulation
- Motors are factory wired and tested
- When using this power exhaust system, clearance between the bottom of the unit and finished roof deck should be a minimum of 10 inches. Some applications may require a taller roof curb for proper installation
- **Economizer with Relief Hood Sold Separately**

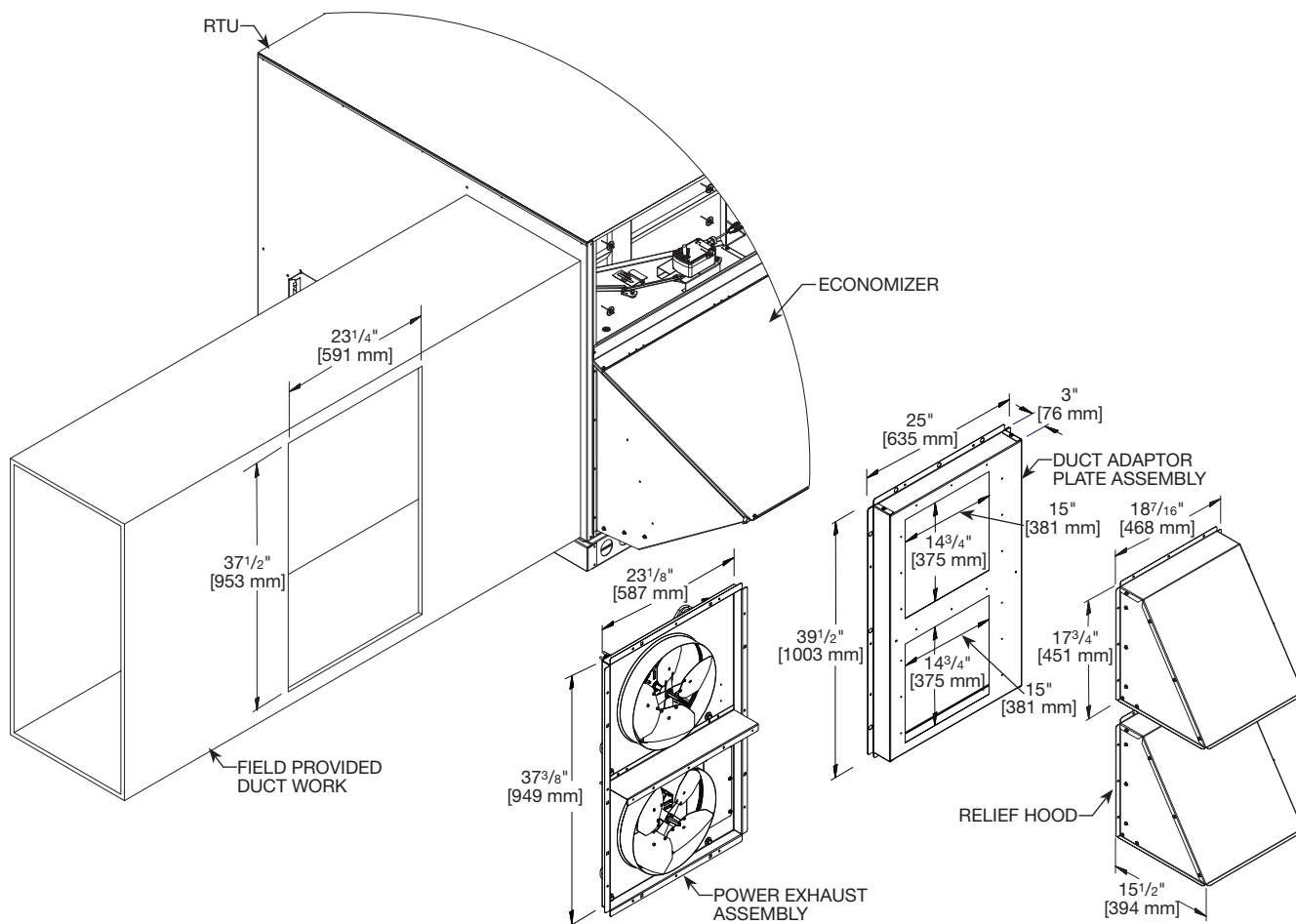

MODEL NO.	VOLT	PHASE	MOTOR				UNIT				@ 0.1 CFM
			HP	RPM	LRA	QTY.	CIR. QTY.	FLA	MCA	FUSE SIZE	
RXXR-RDF03C	208/230	1	1/2	1625	5.86	1	1	2.70	3.38	6	2013
RXXR-RDF03D	460				3.33			1.34	1.68	3	

[] Designates Metric Conversions

POWER EXHAUST KIT, CONVERTIBLE

RXRX-CDF01*

*Voltage Code: C or D

- Convertible between vertical airflow and horizontal airflow
- Compatible with all D-cabinet economizers
- Economizer sold separately

VERTICAL AIRFLOW INSTALLATION

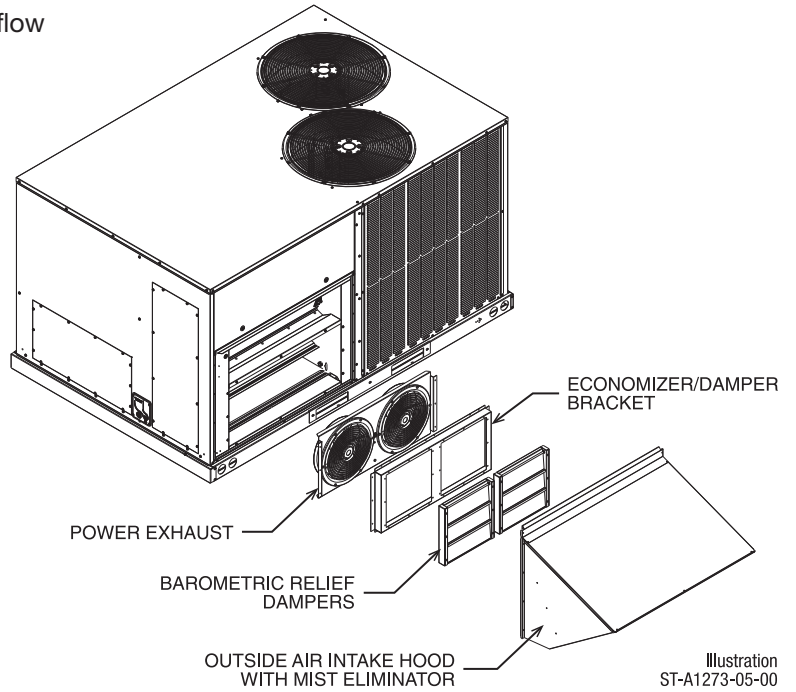

Illustration
ST-A1273-05-00

HORIZONTAL AIRFLOW INSTALLATION

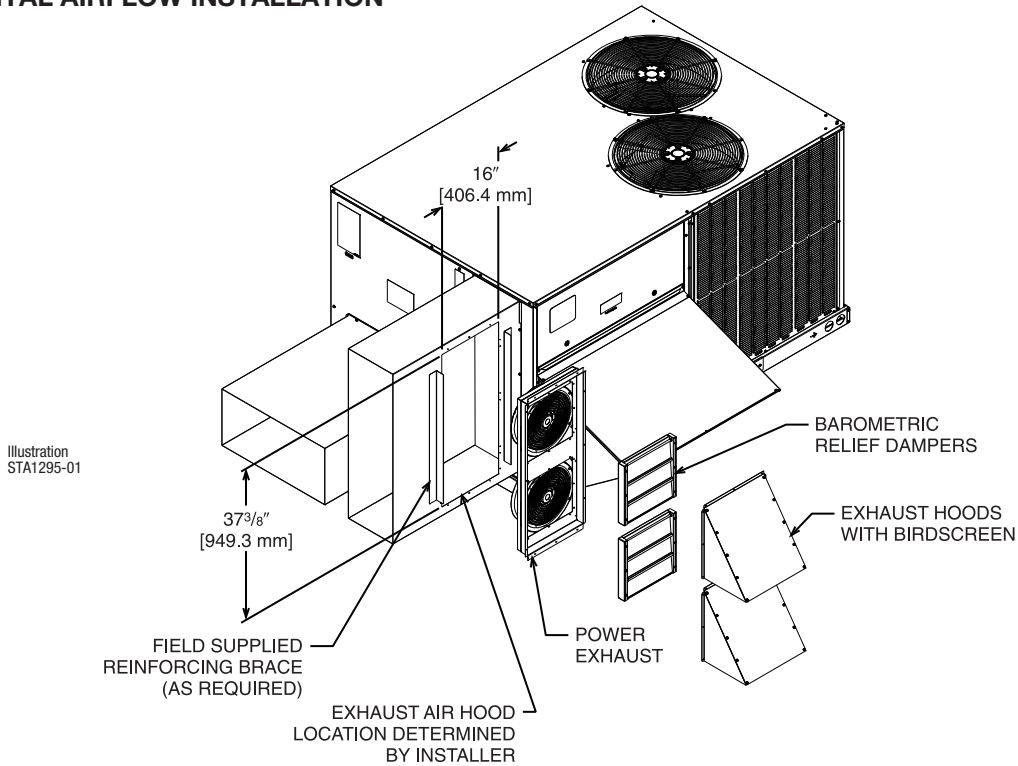

Illustration
STA1295-01

MODEL NO.	NO. OF FANS	VOLTS	PHASE	HP (ea.)	CFM [L/s]*	RPM	FLA (ea.)	LRA (ea.)
RXRX-CDF01C	2	208/230	1	0.47	2200	3000	1.55	1.1
RXRX-CDF01D	2	460	3	0.40	1970	2750	0.51	1.9

*CFM is per fan at 0" w.c. external static pressure.

[] Designates Metric Conversions

FRESH AIR DAMPER

RXRF-ADA1 – Fresh Air Damper, Manual

DOWNFLOW APPLICATION

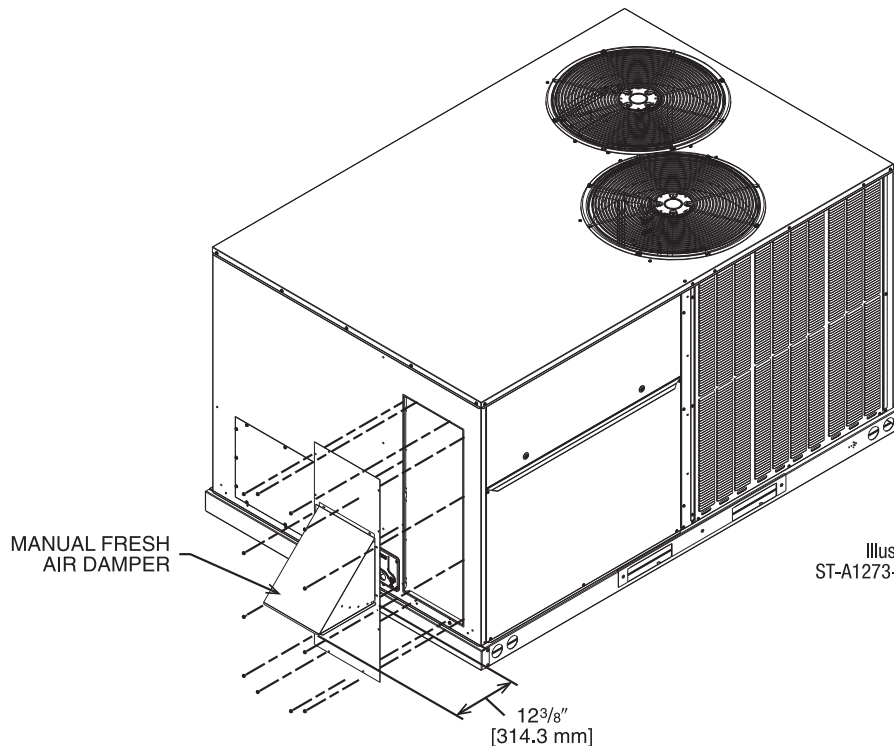

Illustration
ST-A1273-03-00

HORIZONTAL APPLICATION

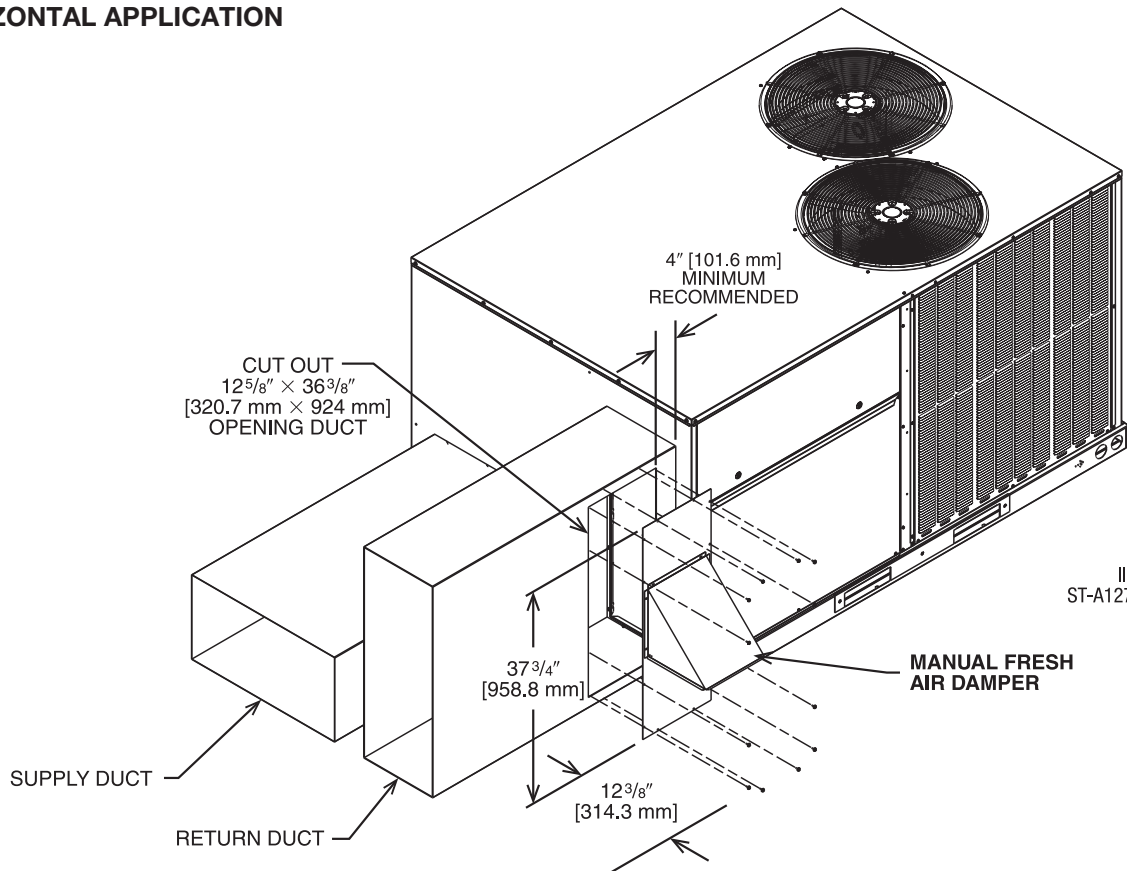

Illustration
ST-A1273-04-00

[] Designates Metric Conversions

FRESH AIR DAMPER (CONTINUED)

RXRF-ADB1 – Fresh Air Damper, Motorized

- Gear Driven Direct Drive Actuator
- Slip-In Design for Easy Installation
- Plug-In Polarized 12-pin

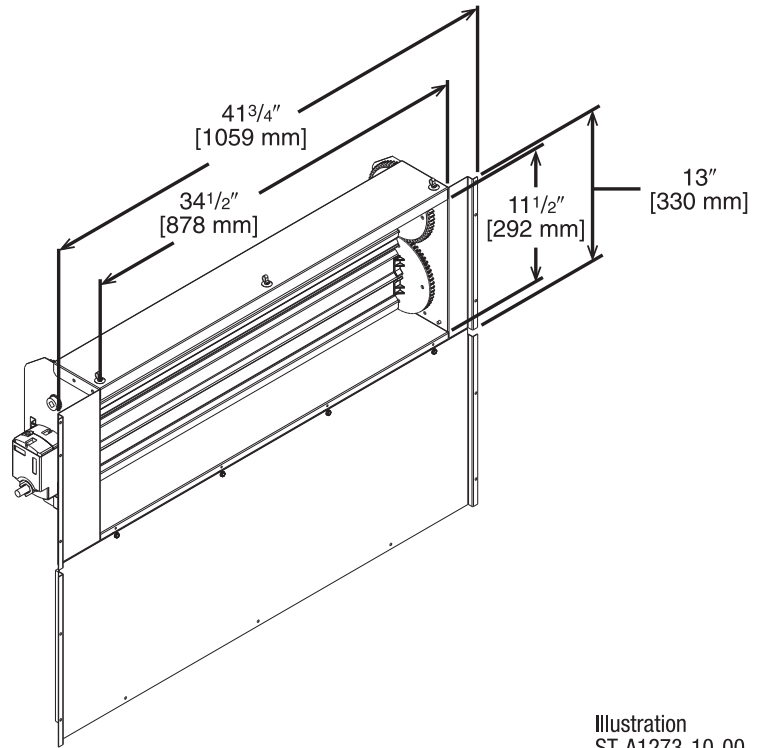

Illustration
ST-A1273-10-00

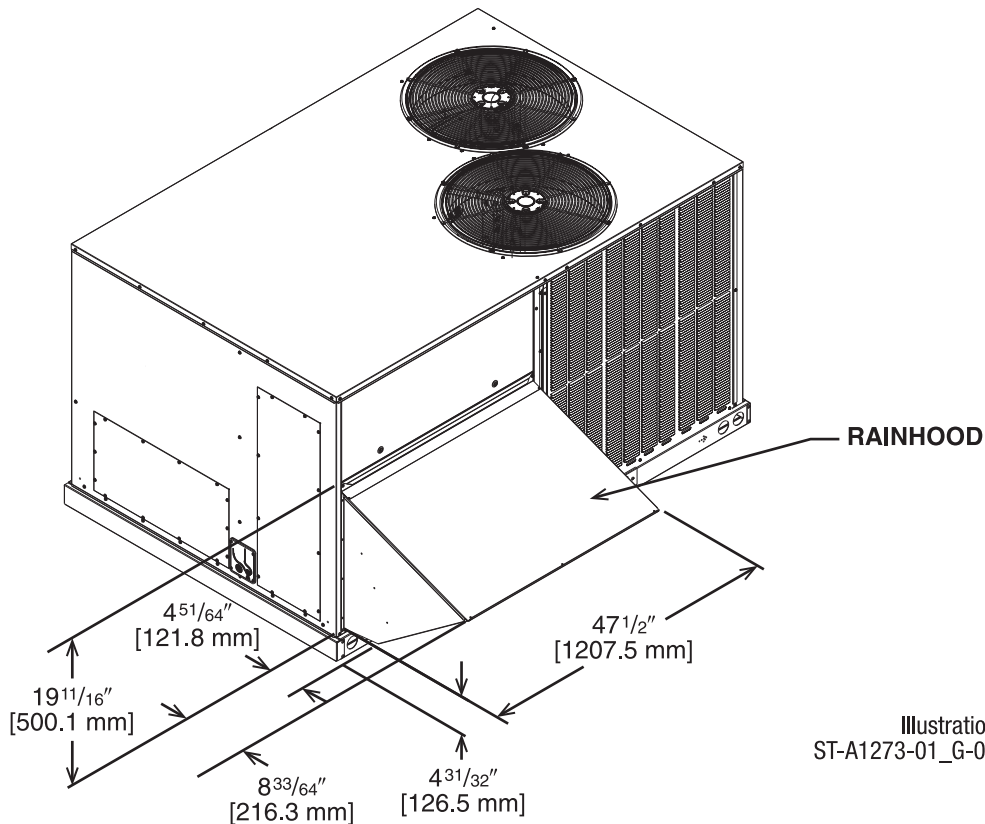

Illustration
ST-A1273-01_G-00

[] Designates Metric Conversions

ROOFCURB ADAPTERS

RXXR-DDCAE

SIDE VIEW

APPROXIMATE STATIC PRESSURE DROP

@2,000 = 0.06" w.g.
@3,000 = 0.12" w.g.
@4,000 = 0.22" w.g.
@5,000 = 0.36" w.g.

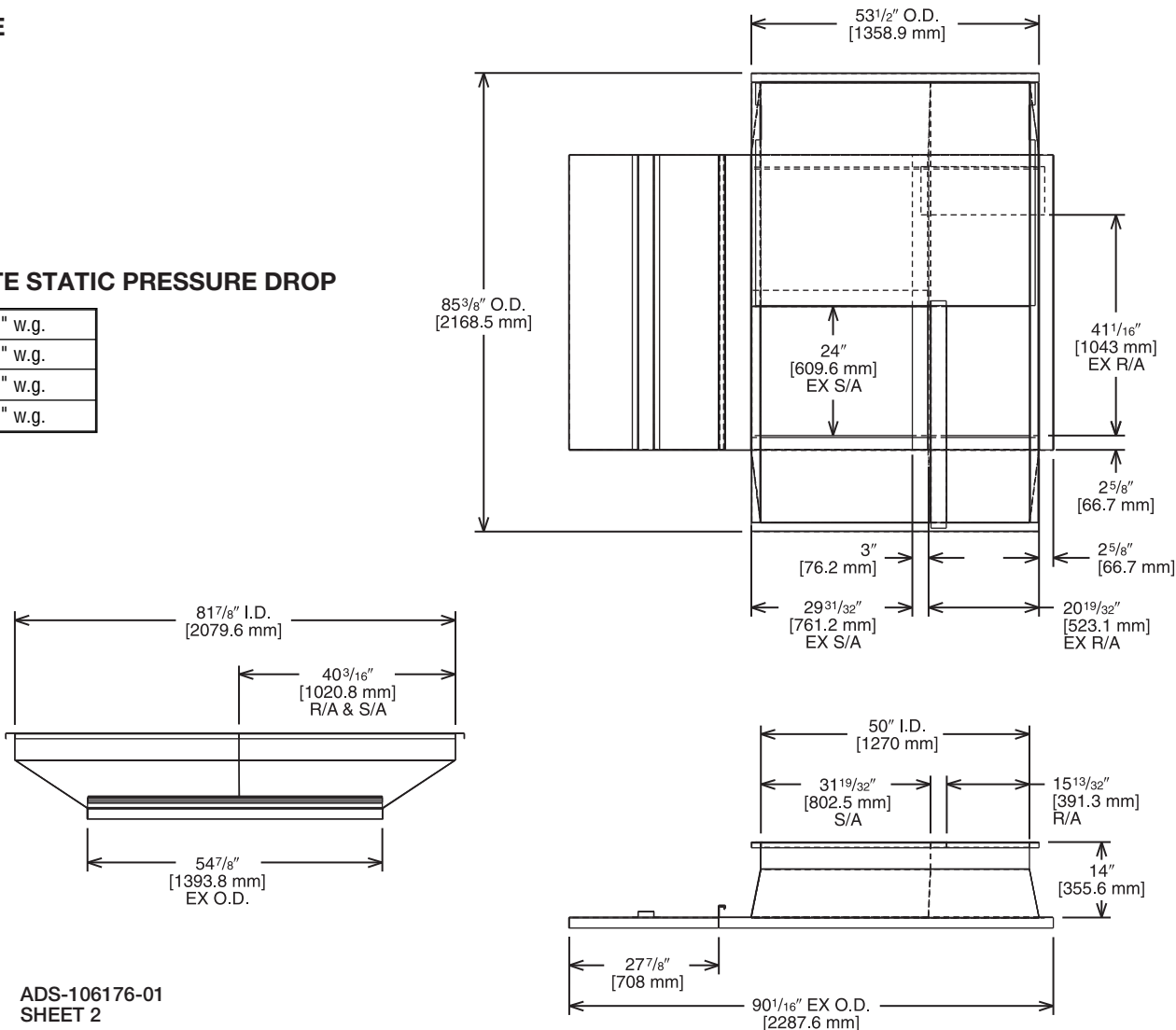

ADS-106176-01
SHEET 2

TOP VIEW

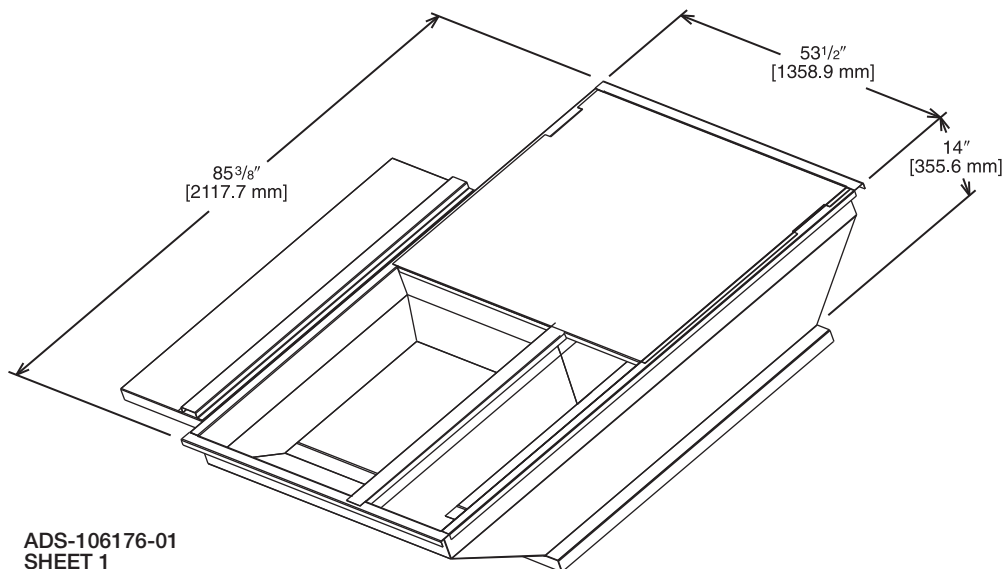

ADS-106176-01
SHEET 1

[] Designates Metric Conversions

ROOFCURBS (Full Perimeter)

- The roofcurb design can be utilized on all 6.5-10 ton RHPDYC models
- Two available heights (14" [356 mm] and 24" [610 mm]) for ALL models
- Quick assembly corners for simple and fast assembly
- Opening provided in bottom pan to match the "Thru the Curb" electrical connection opening provided on the unit base pan
- 1" [25 mm] x 4" [102 mm] Nailer provided
- Insulating panels not required because of insulated outdoor base pan
- Sealing gasket (40' [12.2 m]) provided with Roofcurb
- Packaged for easy field assembly

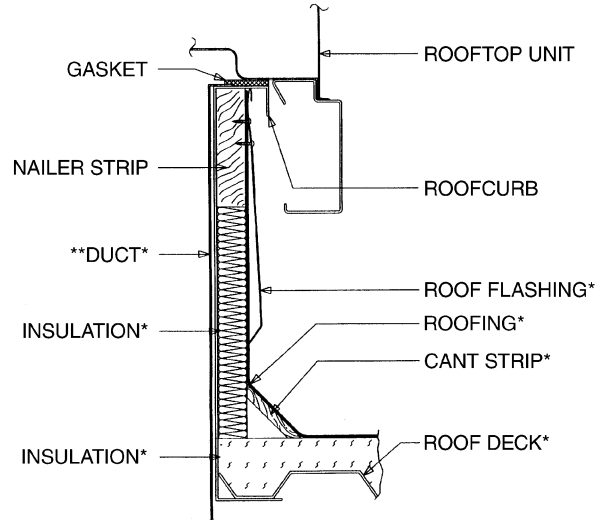

ROOFCURB INSTALLATION—VIEW A

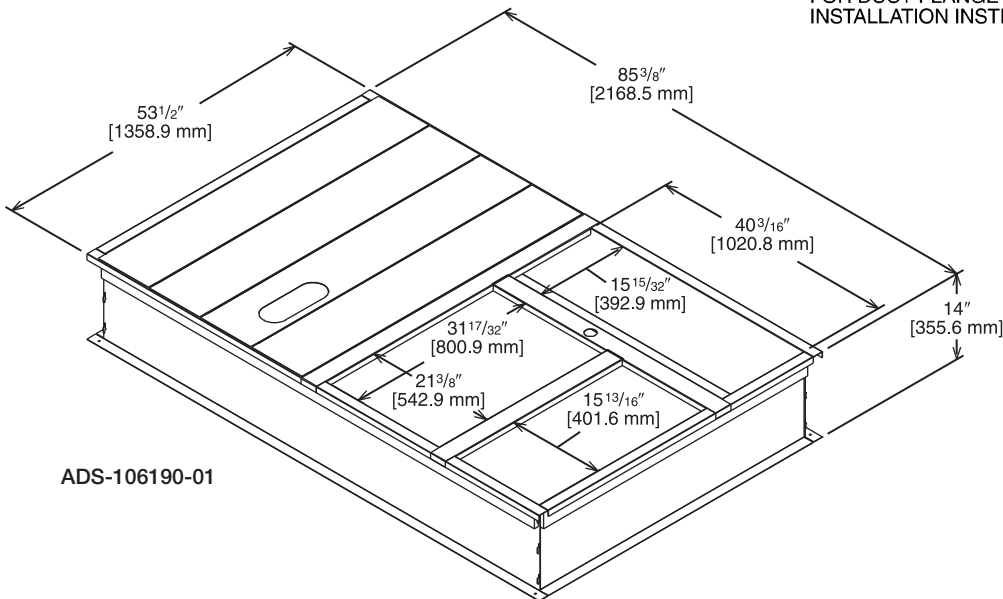

*BY CONTRACTOR

**FOR INSTALLATION OF DUCT AS SHOWN, USE RECOMMENDED DUCT SIZES FROM ROOFCURB INSTALLATION INSTRUCTIONS. FOR DUCT FLANGE ATTACHMENT TO UNIT, SEE UNIT INSTALLATION INSTRUCTIONS FOR RECOMMENDED DUCT SIZES.

ST-A0743-02

View	Roofcurb Model	Height of Curb
A	RXKG-DDD14	14" [356 mm]
A	RXKG-DDD24	24" [610 mm]

• **State of Florida Approved:** Florida approval #26981 and corresponding Technical Evaluation Report (TER) number are available under separate copy. Unit and mounting methods are for high wind resistance and are compliant per Florida Building Code.

[] Designates Metric Conversions

CONCENTRIC DIFFUSER APPLICATION

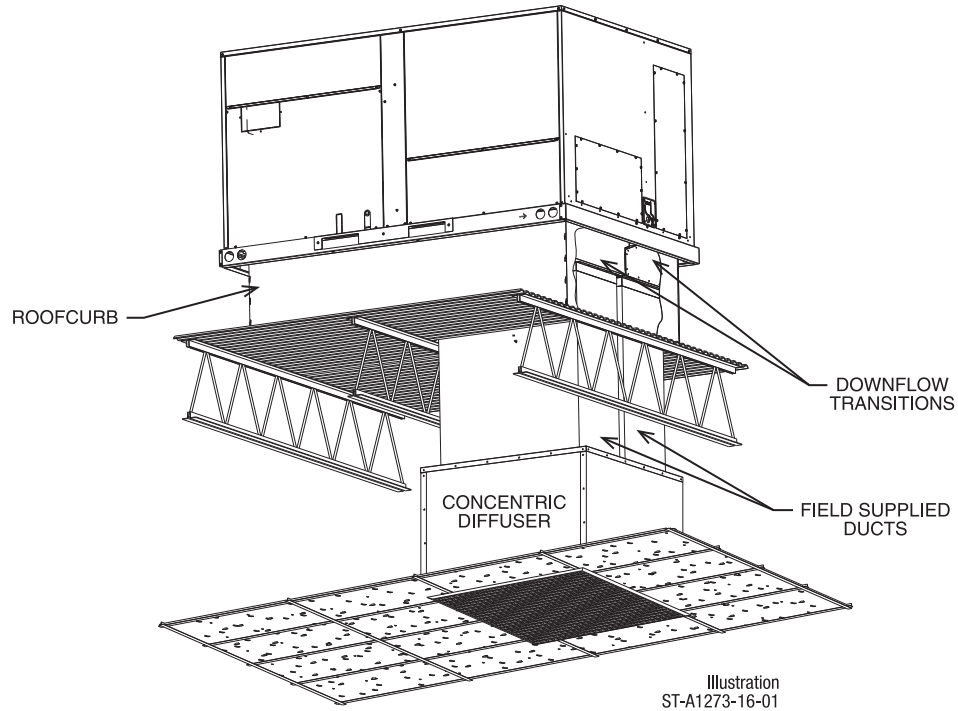

DOWNFLOW TRANSITION DRAWINGS

RXMC-DD01 – Concentric Adapter 6.5, 7.5 & 8.5 Ton Drop

- Used with RXRN-AEF2000 or RXRN-AED2000 Concentric Diffusers

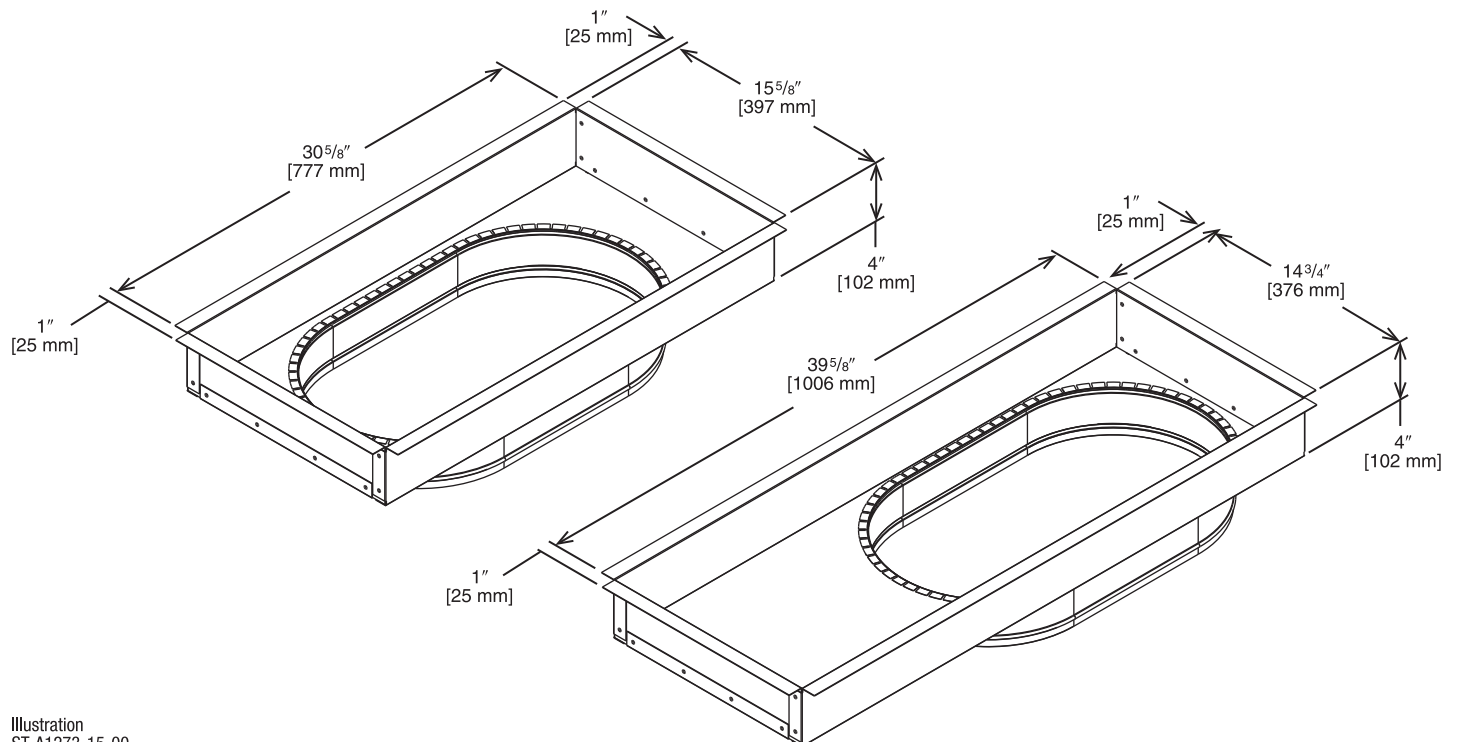

[] Designates Metric Conversions

DOWNFLOW TRANSITION DRAWINGS

RXMC-DD02—Concentric Adapter 10 Ton Drop

- Used with RXRN-AEF3415 or RXRN-AED3415 Concentric Diffusers

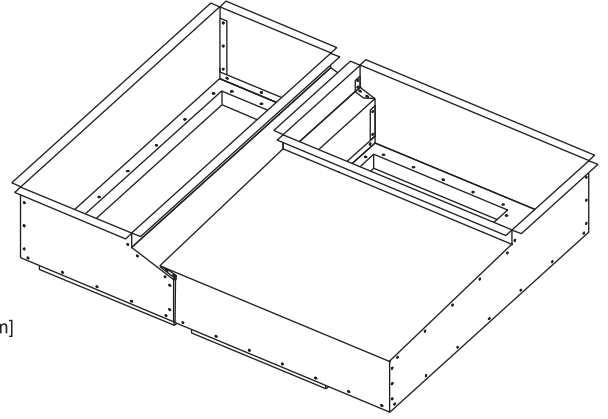
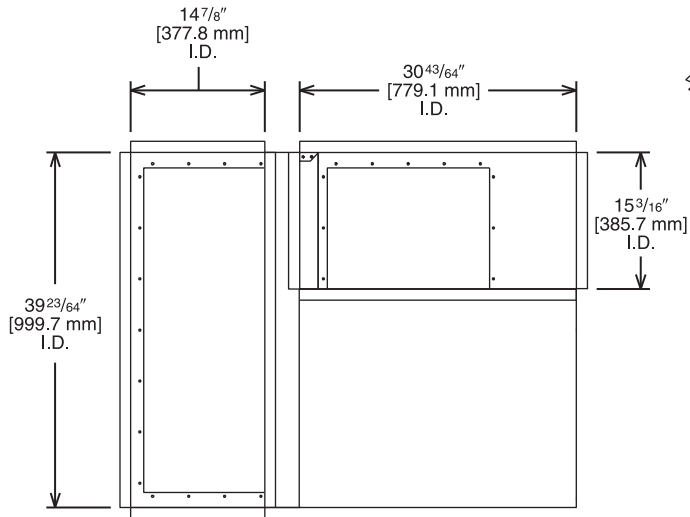
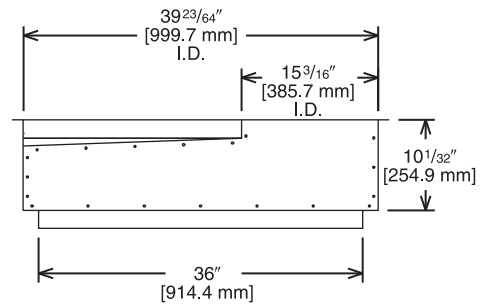
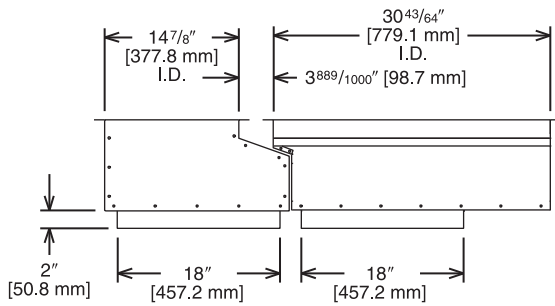

Illustration
 ADS-106193-03



[] Designates Metric Conversions

CONCENTRIC DIFFUSER 6.5, 7.5 & 8.5 TON DROP

RXRN-AED2000

For Use With Downflow Transition (RXMC-DD01) and 20" Round Supply and Return Ducts

- All aluminum diffuser with aluminum return air eggcrate
- Built-in anti-sweat gasket
- Molded fiberglass supports
- Built-in hanging supports
- Diffuser box constructed of sheet metal insulated with 1" [25.4 mm] 1.5 lbs. [.7 kg] duct liner

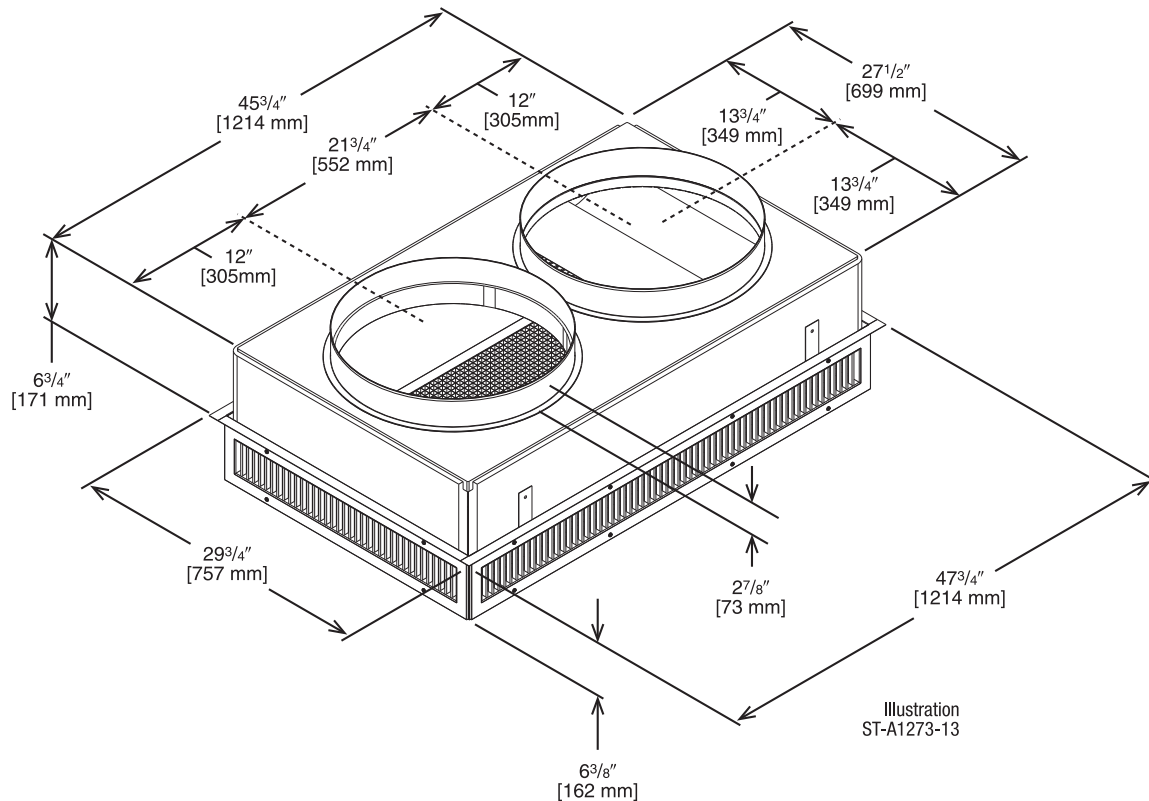

ENGINEERING DATA^①

MODEL NO.	FLOW RATE CFM [L/s]	THROW ^{② ③} FEET [m]	NECK VELOCITY FPM [m/s]	NOISE LEVEL ^④ (dba)
RXRN-AED2000	2600 [1222]	22-39 [6.7-11.9]	669 [3.4]	32
	2800 [1316]	23-40 [7.1-12.2]	720 [3.7]	38
	3000 [1410]	25-42 [7.6-12.8]	772 [3.9]	40
	3200 [1504]	26-43 [7.9-13.1]	823 [4.2]	41
	3400 [1598]	27-45 [8.2-13.7]	874 [4.4]	42
	3600 [1692]	30-50 [9.1-15.2]	925.5 [4.7]	45
	3800 [1786]	32-53 [9.8-16.2]	976.8 [4.9]	48
	4000 [1880]	34-56 [10.4-17.1]	1028.1 [5.2]	50

NOTES: ① All data is based on the air diffusion council guidelines.

② Throw data is based on 75 FPM Terminal Velocities using isothermal air.

③ Throw is based on diffuser blades being directed in a straight pattern.

④ Actual noise levels may vary due to duct design and do not include transmitted unit noise.
Adequate duct attenuation must be provided to reduce sound output from the unit.

[] Designates Metric Conversions

CONCENTRIC DIFFUSER 10 TON DROP

RXRN-AED3415

For Use With Downflow Transition (RXMC-DD02) and 15" x 34" Supply and Return Ducts

- All aluminum diffuser with aluminum return air eggcrate
- Built-in anti-sweat gasket
- Molded fiberglass supports
- Built-in hanging supports
- Diffuser box constructed of sheet metal insulated with 1" [25.4 mm] 1.5 lbs. [.7 kg] duct liner
- Double deflection diffuser with the blades secured by spring steel

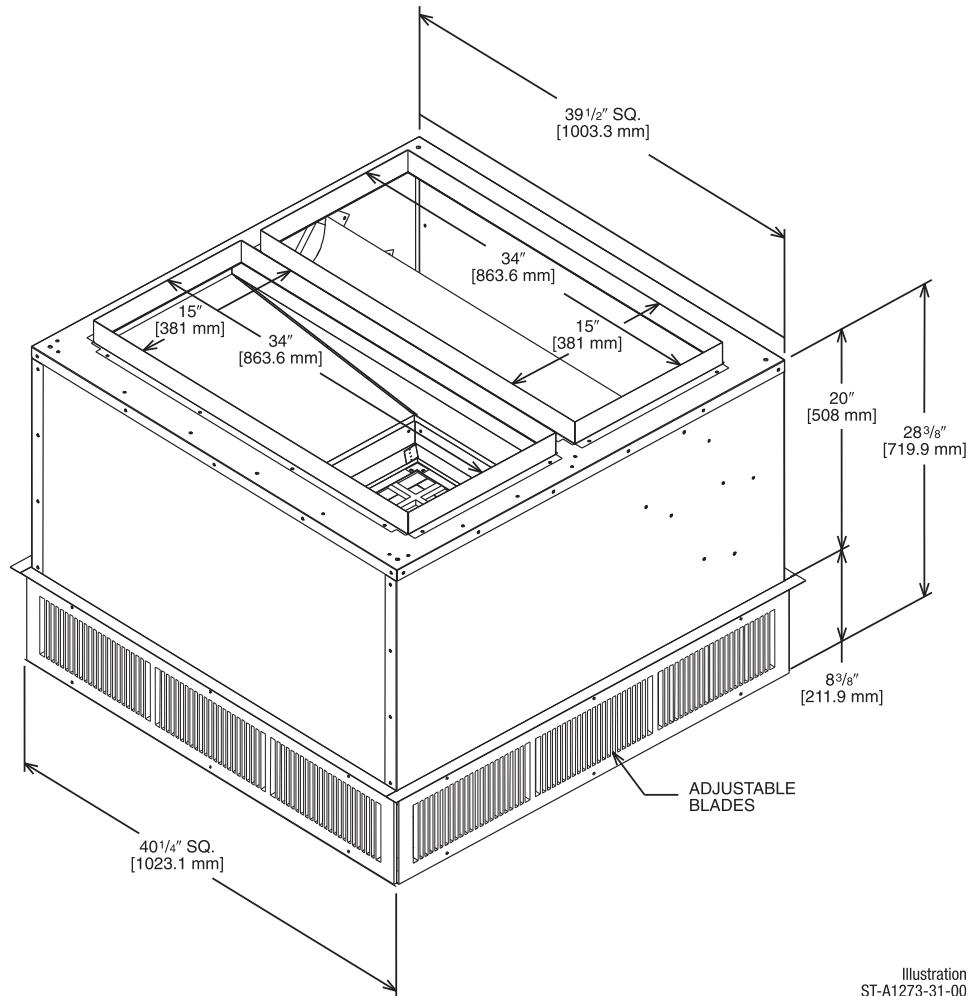

Illustration
ST-A1273-31-00

ENGINEERING DATA^①

MODEL NO.	FLOW RATE CFM [L/s]	THROW ^{② ③} FEET [m]	NECK VELOCITY FPM [m/s]	NOISE LEVEL ^④ (dbA)
RXRN-AED3415	3600 [1692]	26-53 [7.9-16.2]	851 [4.3]	27
	3800 [1786]	27-55 [8.2-16.8]	898 [4.5]	29
	4000 [1880]	29-58 [8.8-17.7]	946 [4.8]	30
	4200 [1974]	31-61 [9.4-18.6]	993 [5.1]	32
	4400 [2068]	32-64 [9.8-19.5]	1040 [5.3]	33
	4600 [2162]	34-66 [10.4-20.1]	1087.5 [5.5]	35

- NOTES:** ① All data is based on the air diffusion council guidelines.
 ② Throw data is based on 75 FPM Terminal Velocities using isothermal air.
 ③ Throw is based on diffuser blades being directed in a straight pattern.
 ④ Actual noise levels may vary due to duct design and do not include transmitted unit noise. Adequate duct attenuation must be provided to reduce sound output from the unit.

[] Designates Metric Conversions

CONCENTRIC DIFFUSER 6.5, 7.5 & 8.5 TON FLUSH

RXRN-AEF2000

For Use With Downflow Transition (RXMC-DD01) 20" Round Supply and Return Ducts

- All aluminum diffuser with aluminum return air eggcrate
- Built-in anti-sweat gasket
- Molded fiberglass supports
- Built-in hanging supports
- Diffuser box constructed of sheet metal insulated with 1" [25.4 mm] 1.5 lbs. [.7 kg] duct liner

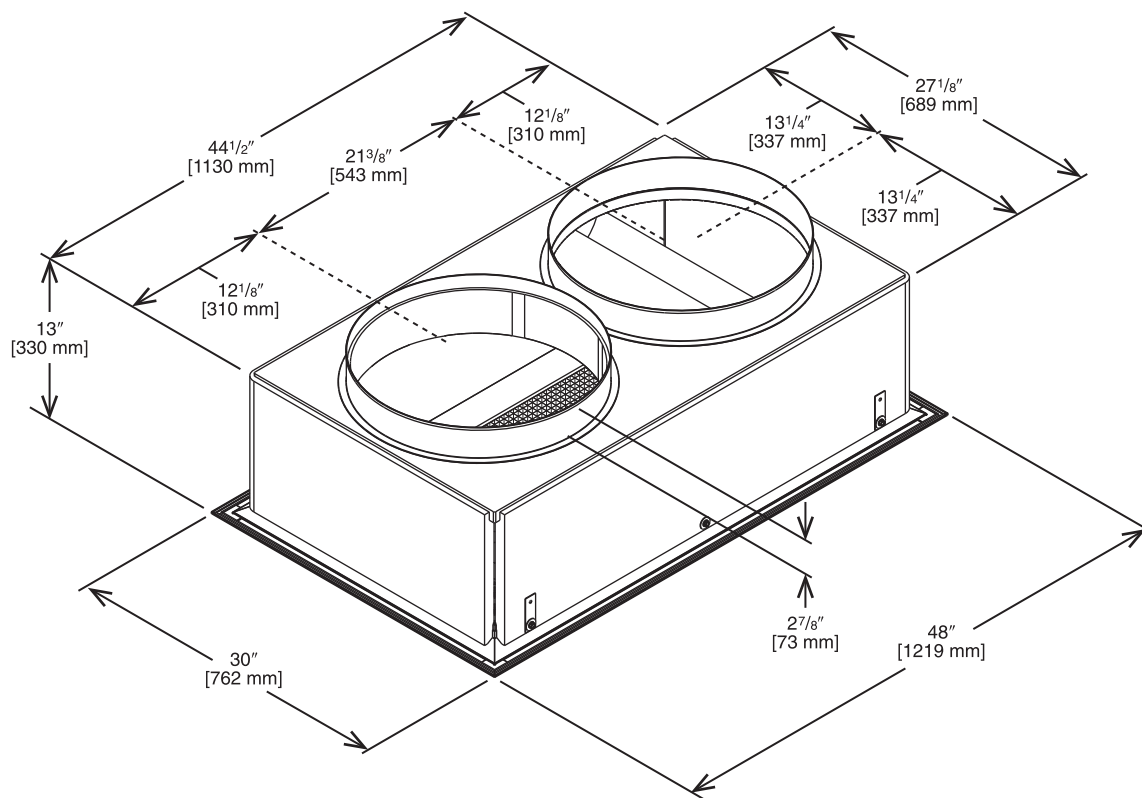

Illustration
ST-A1273-14-00

ENGINEERING DATA^①

MODEL NO.	FLOW RATE CFM [L/s]	THROW ^{② ③} FEET [m]	NECK VELOCITY FPM [m/s]	NOISE LEVEL ^④ (dba)
RXRN-AEF2000	2600 [1222]	17-24 [5.2-7.3]	663 [3.4]	30
	2800 [1316]	18-28 [5.5-8.5]	714 [3.6]	35
	3000 [1410]	20-30 [6.1-9.1]	765 [3.9]	35
	3200 [1504]	22-33 [6.7-10.1]	816 [4.1]	40
	3400 [1598]	23-37 [7-11.3]	867 [4.4]	40
	3600 [1692]	25-38 [7.6-11.6]	918 [4.7]	43
	3800 [1786]	26-39 [7.9-11.9]	969 [4.9]	45
	4000 [1880]	27-40 [8.2-12.2]	1020 [5.2]	48

NOTES: ① All data is based on the air diffusion council guidelines.

② Throw data is based on 75 FPM Terminal Velocities using isothermal air.

③ Throw is based on diffuser blades being directed in a straight pattern.

④ Actual noise levels may vary due to duct design and do not include transmitted unit noise. Adequate duct attenuation must be provided to reduce sound output from the unit.

[] Designates Metric Conversions

CONCENTRIC DIFFUSER 10 TON FLUSH

RXRN-AEF3415

For Use With Downflow Transition (RXMC-DD02) 15" x 34" Supply and Return Ducts

- All aluminum diffuser with aluminum return air eggcrate
- Built-in anti-sweat gasket
- Molded fiberglass supports
- Built-in hanging supports
- Diffuser box constructed of sheet metal insulated with 1" [25.4 mm] 1.5 lbs. [.7 kg] duct liner

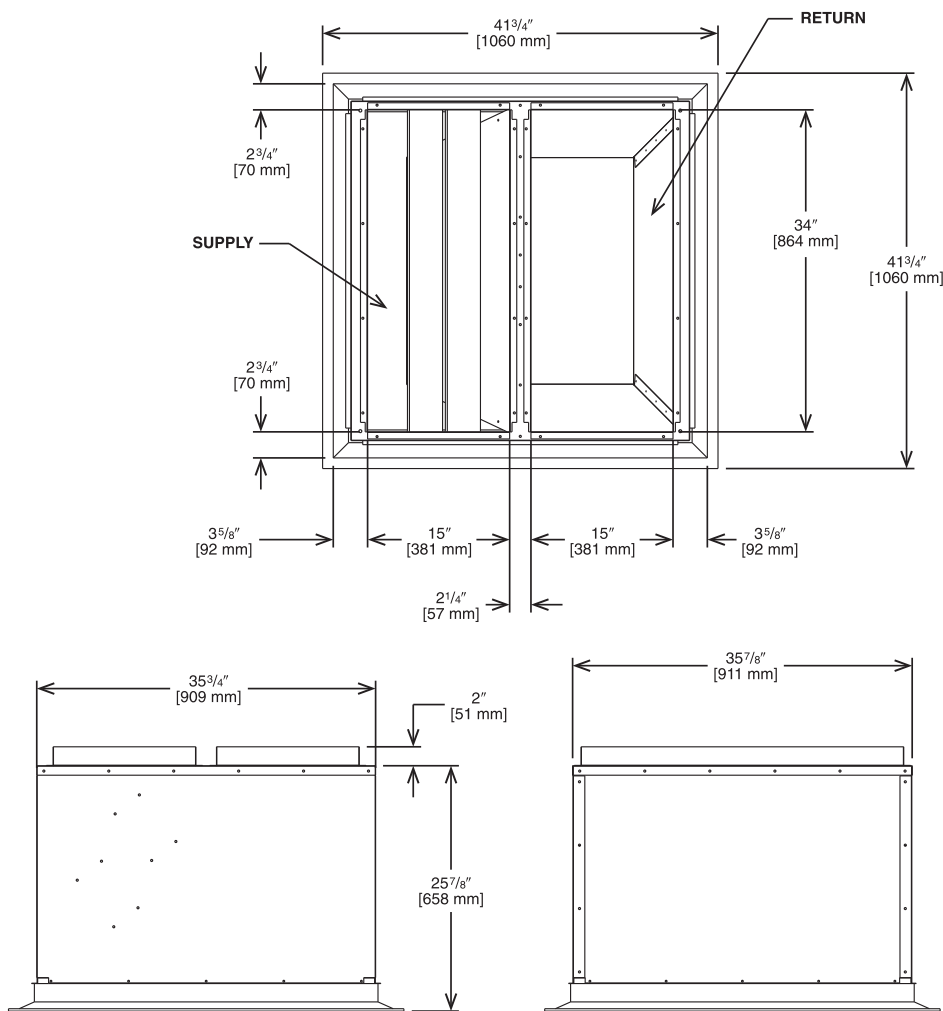

Illustration
ST-A1273-07-00

ENGINEERING DATA^①

MODEL NO.	FLOW RATE CFM [L/s]	THROW ^{② ③} FEET [m]	NECK VELOCITY FPM [m/s]	NOISE LEVEL ^④ (dbA)
RXRN-AEF3415	3600 [1692]	14-34 [4.3-10.4]	844 [4.3]	27
	3800 [1786]	15-36 [4.6-11.1]	891 [4.5]	29
	4000 [1880]	16-37 [4.9-11.3]	938 [4.8]	30
	4200 [1974]	17-39 [5.2-11.9]	985 [5.1]	32
	4400 [2068]	18-41 [5.5-12.5]	1032 [5.2]	33
	4600 [2162]	19-43 [5.8-13.1]	1079 [5.5]	35
	4800 [2256]	20-45 [6.1-13.7]	1126 [5.7]	36

- NOTES:** ① All data is based on the air diffusion council guidelines.
 ② Throw data is based on 75 FPM Terminal Velocities using isothermal air.
 ③ Throw is based on diffuser blades being directed in a straight pattern.
 ④ Actual noise levels may vary due to duct design and do not include transmitted unit noise. Adequate duct attenuation must be provided to reduce sound output from the unit.

[] Designates Metric Conversions

GUIDE SPECIFICATIONS — RHPDYC – 078-120

You may copy this document directly into your building specification. This specification is written to comply with the 2016 version of the “master format” as published by the Construction Specification Institute. www.csinet.org.

ELECTRIC HEAT PUMP PACKAGED ROOFTOP

HVAC Guide Specifications

Size Range: 6.5 to 10 Nominal Tons

1.00 General:

- A. Outdoor, rooftop mounted, electrically controlled, heating and cooling unit utilizing a(n) hermetic scroll compressor(s) for cooling duty and heat pump for heating duty.
- B. Factory assembled, single-piece heating and cooling rooftop unit. Contained within the unit enclosure shall be all factory wiring, piping, controls, and special features required prior to field start-up.
- C. Unit shall use environmentally safe, R-454B refrigerant.
- D. Unit shall be installed in accordance with the manufacturer’s instructions.
- E. Unit must be selected and installed in compliance with local, state, and federal codes.
- F. Model and serial data shall be printed inside the control box.

1.01 Quality Assurance:

- A. Unit meets ASHRAE 90.1 2022 minimum efficiency requirements.
- B. Unit shall be rated in accordance with AHRI Standards 340/360.
- C. Unit shall be designed to conform to ASHRAE 15.
- D. Unit shall be UL-tested and certified in accordance with Standards and UL-listed and certified under Canadian standards as a total package for safety requirements.
- E. Insulation and adhesive shall meet NFPA 90A requirements for flame spread and smoke generation.
- F. Unit casing shall be capable of withstanding 1000-hour salt spray exposure per ASTM® B117 (scribed specimen).
- G. Roof curb shall be designed to conform to NRCA Standards.
- H. Unit shall be subjected to a completely automated run test on the assembly line. The data for each unit will be stored at the factory, and must be available upon request.
- I. Unit shall be designed in accordance with UL Standard 60335-2-40 4th Edition. including tested to withstand rain.
- J. Unit shall be constructed to prevent intrusion of snow and tested to prevent snow intrusion into the control box up to 40 mph.

1.02 Manufacturer Qualifications

- A. Unit shall be designed in accordance with ISO 9001:2015, and shall be manufactured in a facility registered by ISO 9001:2015.

1.03 Installer Qualifications

- A. The installer shall be trained to install and service equipment with A2L refrigerants.

1.04 Delivery, Storage, and Handling:

- A. Unit shall be stored and handled per manufacturer’s recommendations.
- B. Unit lifted by crane requires either shipping top panel or spreader bars.
- C. Unit shall only be stored or positioned in the upright position.

1.05 Unit Cabinet:

- A. Unit cabinet shall be constructed of galvanized steel.
- B. Unit cabinet exterior paint shall be pre-painted steel.
- C. The sheet-metal cabinet shall be constructed of 18-gauge material for structural components with an underlying coat of G90.
- D. Evaporator fan compartment interior cabinet insulation shall conform to AHRI Standards 210/240 or 340/360 minimum exterior sweat criteria. Interior surfaces shall be insulated with a minimum 1/2-in. thick, 1.6 lbs density, flexible fiberglass insulation, foil faced on the air side. Aluminum foil-faced fiberglass insulation shall be used in the gas heat compartment.
- E. Shall utilize uniform screw sizing.
- F. Base of unit shall have a location for thru-the-base gas and electrical connections standard.
- G. Base Rail:
 - i. Unit shall have base rails on a minimum of 4 sides.
 - ii. Holes shall be provided in the base rails for rigging shackles to facilitate maneuvering and overhead rigging.
 - iii. Holes shall be provided in the base rail for moving the rooftop unit with a fork truck.
 - iv. Base rail shall be a minimum of 14 gauge thickness.
- H. Condensate pan and connections:
 - i. Shall be a sloped condensate drain pan made of a non-corrosive material and be removable for cleaning.
 - ii. Shall comply with ASHRAE Standard 62.
 - iii. Shall use a 3/4" NPT drain connection, possible either through the bottom or side of the drain pan. Connection shall be made per manufacturer’s recommendations.
 - iv. Shall be able to be easily removed.
 - v. Shall be separate from the coil.

- I. Standard factory-installed condensate overflow sensor.
- J. Top panel
 - i. Shall be a single piece top panel over indoor section.
- K. Electrical Connections:
 - i. All unit power wiring may enter unit cabinet via a single, factory-prepared, continuous raised flange opening in base pan. Unit power wiring may also enter unit cabinet through a dedicated entry point on the condenser side of the unit.
 - ii. Thru-the-base capability:
 - a. Standard unit shall have a thru-the-base electrical location(s) using a raised, continuous raised flange opening in the basepan.
 - b. No basepan penetration, other than those authorized by the manufacturer, is permitted.
- L. Component access panels (standard):
 - i. Cabinet panels shall be easily opened for servicing.
 - ii. Stainless steel metal hinges are standard on all doors
 - iii. Panels covering control box, indoor fan, indoor fan motor, and electric or gas heater components (where applicable), shall have 1/4 turn latches.

1.06 Operating Characteristics:

- A. Unit shall be capable of starting and running at 115°F (46°C) ambient outdoor temperature, meeting maximum load criteria of AHRI Standard 340/360 at ± 10% voltage.
- B. Compressor with standard controls shall be capable of operation down to 30°F (-1.1°C), ambient outdoor temperatures. Low ambient accessory kit is necessary if mechanically cooling at ambient temperatures to 40°F (4°C).
- C. Unit shall discharge supply air vertically or horizontally as shown on contract drawings.
- D. Unit shall be factory configured for vertical supply & return configurations.
- E. Unit shall be field convertible from vertical to horizontal configuration.
- F. Unit shall be capable of mixed operation: vertical supply with horizontal return or horizontal supply with vertical return.

1.07 Electrical Requirements

- A. Main power supply voltage, phase, and frequency must match those required by the manufacturer.

1.08 Evaporator Fan Compartment:

- A. Interior cabinet surfaces shall be insulated with a minimum 1-in. thick, minimum 1.6 LB density, flexible fiberglass insulation bonded with foil face on the air side.
- B. Insulation and adhesive shall meet NFPA 90A requirements for flame spread and smoke generation.
- C. Insulation shall also be mechanically fastened with welded pin and retainer washer.

1.09 Thermostats

- A. Thermostat must:
 - i. Energize both “W” and “G” when calling for heat.
 - ii. Have capability to energize 1 stage of cooling, and at least 1 stage of heating
 - iii. All units shall have the capability to energize 3 stages.
 - iv. Include capability for occupancy scheduling.

1.10 Electronic Control System for HVAC:

- A. Shall be complete with self-contained low-voltage control circuit protected by a fuse on the 24-V transformer side (090-150 units have a resettable circuit breaker).
- B. Shall utilize color-coded wiring.
- C. Shall include a central control terminal board to conveniently and safely provide connection points for vital control functions such as: smoke detectors, phase monitor, economizer, thermostat, building management systems, loss of charge, freeze sensor, high-pressure switches.
- D. Unit shall include a minimum of one 11-position terminal block for control wiring.
- E. Unit control board incorporates a 22 character LCD display to easily navigate through the Human Machine Interface (HMI) and with easy-to-understand fault codes for status and diagnostics.

1.10.01 Safeties:

- A. Compressor over-temperature, over current.
- B. Standard Low-pressure switch:
 - i. Units shall have low-pressure, loss of charge automatic reset device that will shut off compressor when tripped.
 - ii. Low-pressure control
 - a. Provides active protection in both heating and cooling modes at all outdoor ambient temperatures. The low-pressure control is an automatic reset type and opens at approximately 15 PSIG and closes at approximately 40 PSIG. Operation is slightly different between cooling and heating modes.

- C. Standard High-pressure Switch:
 - i. Unit shall be equipped with high-pressure switch device that will shut off compressor when tripped.
 - ii. High-pressure control.
 - iii. The high-pressure control is an automatic reset type and opens at approximately 610 PSIG and closes at approximately 420 PSIG. The compressor and fan motor will stop when the high-pressure control opens and will start again if the high side pressure drops to approximately 420 PSIG where the automatic reset high-pressure control resets. If the high-pressure control opens 3 times within a particular call for heating or cooling operation, the defrost control will lock out compressor and outdoor fan operation.
- D. Automatic reset, motor thermal overload protector.
- E. The unit must be permanently grounded.
- F. Components are not compatible between different refrigerants. Do not use R-410A service equipment or components on R-454B equipment. System or part failure could occur.
- G. Heating section shall be provided with the following minimum protections.
 - i. High-temperature limit switches.

1.11 Standard Filter Section:

- A. Filters shall consist of factory-installed, low velocity, throwaway 2-in. thick fiberglass filters of commercially available sizes.
- B. Unit will accept both 2-in. and 4-in. filters.
- C. Filter face velocity shall not exceed 365 fpm at nominal airflows.
- D. Filters shall be accessible through an access panel with “no-tool” removal as described in the unit cabinet section of the specification.
- E. Filters access is specified in the unit cabinet section of this specification.
- F. Filters shall be held in place by metal rods, facilitating easy removal and installation.

1.12 Coils

- A. Standard Aluminum/MicroChannel Coils:
 - i. Standard evaporator and condenser coils shall be aluminum.
 - ii. Evaporator and condenser coils shall be leak tested to 150 PSIG, pressure tested to 400 PSIG, and qualified to burst test at 2,200 psi.

1.13 Refrigerant Components:

- A. Refrigerant circuit shall include the following control, safety, and maintenance features:
 - i. TXV metering system shall prevent mal-distribution of two-phase refrigerant.
 - ii. Refrigerant filter drier.
 - iii. Service gauge connections on suction and discharge lines.
 - iv. External pressure gauge ports access shall be located in front exterior of cabinet.
 - v. External gauge ports shall be lockable.
 - vi. TXV refrigerant metering system with two TXVs: one for cooling operation and one for heating operation.
- B. Compressors:
 - i. Unit shall use one Tandem scroll compressors: one two-stage compressor and one single-stage compressor, with internal line break overload and high-pressure protection.
 - ii. Compressor motors shall be cooled by refrigerant gas passing through motor windings.
 - iii. Compressors shall be internally protected from high discharge temperature conditions.
 - iv. Compressors shall be protected from an over-temperature and over-amperage conditions by an internal, motor overload device.
 - v. Compressor shall be factory mounted on rubber grommets.
 - vi. Compressor motors shall have internal line break thermal and current overload protection.
 - vii. Compressor shall have molded electrical plug.

1.14 Evaporator Fan and Motor:

- A. Evaporator Fan Motor:
 - i. Shall have permanently lubricated bearings.
 - ii. Shall have inherent automatic-reset thermal overload protection.
- B. Direct Drive Evaporator Fan:
 - i. Direct drive ECM technology with multiple speed of 0-10Vdc (%) input from the controller.
 - ii. Shall use sealed, permanently lubricated ball-bearing type.
 - iii. Blower fan shall be backward curved centrifugal type.
 - iv. Shall be constructed from steel with a corrosion resistant finish and dynamically balanced.
- C. Blower Assembly:
 - i. Entire assembly shall be able to slide out completely.
 - ii. Shall be able to slide-out without the removal of the roof and condenser fan motors.

1.15 Condenser Fans and Motors:

- A. Condenser Fan Motors:
 - i. Shall be a totally enclosed motor.
 - ii. Shall use permanently lubricated bearings.
 - iii. Shall have inherent thermal overload protection with an automatic reset feature.
 - iv. Shall use a shaft-down design. Shaft-up designs including those with “rain-slinger devices” shall not be allowed.
- B. Condenser Fans:
 - i. Shall be a direct-driven propeller type fan.
 - ii. Shall have blades riveted to corrosion-resistant steel spiders and shall be dynamically balanced.

1.16 RTU-C Controller:

- A. Shall be ASHRAE 62-2001 compliant.
- B. Shall accept 18-32VAC input power.
- C. Shall have an operating temperature range from -40°F (-40°C) to 140°F (60°C), 10%–95% RH (non-condensing).
- D. Controller shall accept the following inputs: space temperature, setpoint adjustment, outdoor air temperature, indoor air quality, outdoor air enthalpy, compressor lock-out, fire shutdown, enthalpy switch and fan status/filter status/humidity/remote occupancy.
- E. Shall accept a CO₂ sensor in the conditioned space, and be Demand Control Ventilation (DCV) ready.
- F. Shall provide the following outputs: Economizer, fan, cooling stage 1, cooling stage 2, cooling stage 3, electric heat stage 1, electric heat stage 2, heat pumping heating stage 1, heat pump heating stage 2, heat pump heating stage 3 exhaust, occupied.
- G. Unit shall provide surge protection for the controller through a circuit breaker.
- H. Shall have a built-in BACnet IP or BACnet MS/TP allowing the unit to be able to communicate at an adjustable Baud rate.
 - I. Shall have an LCD display independently showing the status of activity on the communication bus, and processor operation.
- J. Software upgrades will be accomplished by local download. Software upgrades through chip replacements are not allowed.
- K. Shall be shock resistant in all planes to 5G peak, 11ms during operation, and 100G peak, 11ms during storage.
- L. Shall be vibration resistant in all planes to 1.5G @ 20-300 Hz.
- M. Shall support a bus length of 4000 ft max, 60 devices per 1000 ft section, and 1 RS-485 repeater per 1000 ft sections.
- N. Shall allow access of up to 62 network variables (SNVT). Shall be compatible with all open controllers.
- O. Shall have an LCD display independently showing the status of serial communication, running, errors, power, all digital outputs, and all analog inputs.
- P. Shall be natively equipped with Modbus® communication protocol.

1.17 Special Features:

- A. Integrated Economizers:
 - i. Integrated, parallel modulating blade design type capable of simultaneous economizer and compressor operation.
 - ii. Independent modules for vertical or horizontal return configurations shall be available. Vertical return modules shall be available as a factory-installed option.
 - iii. Damper blades shall be galvanized steel. Plastic or composite blades on intake or return shall not be acceptable.
 - iv. Shall include all hardware and controls to provide free cooling with outdoor air when temperature and/or humidity are below setpoints.
 - v. Shall be equipped with dampers for both the outdoor ventilation air and the return air for positive air stream control.
 - vi. Shall be equipped with low-leakage dampers, not to exceed 2% leakage at 1 in. wg pressure differential.
 - vii. Shall be capable of introducing up to 100% outdoor air.
 - viii. Shall be equipped with a barometric relief damper capable of relieving up to 100% return air.
 - ix. Shall be designed to close damper(s) during loss-of-power situations with spring return built into motor.
 - x. Enthalpy sensor shall be provided as standard. Outdoor air sensor set point shall be adjustable and shall range from 40 to 100°F / 4 to 38°C. Additional sensor options shall be available as accessories.
 - xi. The economizer controller shall also provide control of an accessory power exhaust unit function. Factory set at 60%, with a range of 0% to 100%.
 - xii. The economizer shall maintain minimum airflow into the building during occupied period and provide design ventilation rate for full occupancy.
 - xiii. Dampers shall be completely closed when the unit is in the unoccupied mode.
 - xiv. Economizer controller shall accept a 0-10VDC, 0-5VDC, 2-10Vdc, or 4-20ma CO₂ sensor input for IAQ/DCV control. In this mode, dampers shall modulate the outdoor-air damper to provide ventilation based on the sensor input.
 - xv. Economizer controller shall provide indications when in free cooling mode, in the DCV mode, or the exhaust fan contact is closed.
 - xvi. Economizer wire harness will have provision for smoke detector available in supply and return options.
 - xvii. Shall provide fault detection and diagnostics (FDD) system in accordance with local code. Faults shall be communicated out on an alarm signal.

- B. Two-Position Motorized Damper:
 - i. Damper shall be a Two-Position Motorized Damper. Damper travel shall be from the full closed position to the field adjustable %-open setpoint.
 - ii. Damper shall include adjustable damper travel from 25% to 100% (full open).
 - iii. Damper shall include single or dual blade, gear driven dampers and actuator motor.
 - iv. Actuator shall be direct coupled to damper gear. No linkage arms or control rods shall be acceptable.
 - v. Damper will admit up to 100% outdoor air for applicable rooftop units.
 - vi. Damper shall close upon indoor (evaporator) fan shutoff and/or loss of power.
 - vii. The damper actuator shall plug into the rooftop unit's wiring harness plug. No hard wiring shall be required.
 - viii. Outside air hood shall include aluminum water entrainment filter
- C. Manual Damper
 - i. Manual damper package shall consist of damper, air inlet screen, and rain hood which can be preset to admit up to 50% outdoor air for year-round ventilation.
- D. Condenser Coil Hail Guard Assembly:
 - i. Shall protect against damage from hail.
 - ii. Shall be louvered style.
- E. Unit-Mounted, Non-Fused Disconnect Switch:
 - i. Switch shall be factory-installed, internally mounted.
 - ii. National Electric Code (NEC) and UL approved non-fused switch shall provide unit power shutoff.
 - iii. Shall be accessible from outside the unit.
 - iv. Shall provide local shutdown and lockout capability.
- F. Convenience Outlet:
 - i. Non-Powered convenience outlet.
 - ii. Outlet shall be powered from a separate 115-120V power source.
 - iii. A transformer shall not be included.
 - iv. Outlet shall be field-installed and internally mounted with easily accessible 115V female receptacle.
 - v. Outlet shall include 15 amp GFI receptacle with independent fuse protection.
 - vi. Outlet shall be accessible from outside the unit.
- G. Propeller Power Exhaust:
 - i. Power exhaust shall be used in conjunction with an integrated economizer.
 - ii. Independent modules for vertical or horizontal return configurations shall be available.
 - iii. Horizontal power exhaust shall be mounted in return ductwork.
 - iv. Power exhaust shall be controlled by economizer controller operation.
Exhaust fans shall be energized when dampers are open.
 - v. Capable of adjustable but constant volume.
- H. Roof Curbs (Vertical):
 - i. Formed galvanized steel with wood nailer strip and shall be capable of supporting entire unit weight.
 - ii. Permits installation and securing of ductwork to curb prior to mounting unit on the curb.
- I. Return Air Enthalpy Sensor
 - i. The return air enthalpy sensor shall be used in conjunction with an outdoor air enthalpy sensor to provide differential enthalpy control.
- J. Indoor Air Quality (CO₂) Sensor:
 - i. Shall be able to provide demand ventilation indoor air quality (IAQ) control.
 - ii. The IAQ sensor shall be available in duct mount, wall mount, or wall mount with LED display.
The set point shall have adjustment capability.
- K. Smoke detectors:
 - i. Shall be a Four-Wire Controller and Detector.
 - ii. Shall be environmental compensated with differential sensing for reliable, stable, and drift-free sensitivity.
 - iii. Shall use magnet-activated test/reset sensor switches.
 - iv. Shall have tool-less connection terminal access.
 - v. Shall have a recessed momentary switch for testing and resetting the detector.
 - vi. Controller shall include:
 - a. One set of normally open alarm initiation contacts for connection to an initiating device circuit on a fire alarm control panel
 - b. Two Form-C auxiliary alarm relays for interface with rooftop unit or other equipment
 - c. One Form-C supervision (trouble) relay to control the operation of the Trouble LED on a remote test/reset station
 - d. Capable of direct connection to two individual detector modules.
 - e. Can be wired to up to 14 other duct smoke detectors for multiple fan shutdown applications.

- L. Barometric Relief:
 - i. Shall include damper, seals, hardware, and hoods to relieve excess building pressure.
 - ii. Damper shall gravity-close upon shutdown.
- M. Time Guard:
 - i. Shall prevent compressor short cycling by providing a 5-minute delay (± 2 minutes) before restarting a compressor after shutdown for any reason.
 - ii. One device shall be required per compressor.
- N. Standard Factory-Installed Overflow Switch
 - i. Switch shall monitor the condensate level in drain pan and stops compression operation when overflow conditions occur
- O. Access Panels:
 - i. Hinges with $\frac{1}{4}$ turn fasteners shall be permanently attached.
 - ii. Hinges shall be powder coated and made from stainless steel.
- P. Head Pressure Control Package
 - i. Controller shall control coil head pressure by condenser-fan cycling.
- Q. Fan/Filter Status Switch:
 - i. Switch shall provide status of indoor evaporator fan or filter.
 - ii. Status shall be displayed either over communication bus (when used with direct digital controls) or through the controller LCD display inside the unit control box.
- R. Refrigerant Leak Detection System:
 - i. Shall be standard and factory-installed in every unit.
 - ii. Shall trigger a fault code to the unit controller and initiate mitigation procedures.



FRIEDRICH

1 8 8 3

GENERAL TERMS OF LIMITED WARRANTY*

Friedrich® will furnish a replacement for any part of this product which fails in normal use and service within the applicable periods stated, in accordance with the terms of the limited warranty.

***For complete details of the Limited and Conditional Warranties, including applicable terms and conditions, contact your local contractor or the Manufacturer for a copy of the product warranty certificate.**

Compressor

Commercial ApplicationsFive (5) Years

Parts

Commercial ApplicationsOne (1) Year

Before proceeding with installation, refer to installation instructions packaged with each model, as well as complying with all Federal, State, Provincial, and Local codes, regulations, and practices.

© 2026 Rheem Manufacturing Company. Trademarks are property of their respective owners.

In keeping with its policy of continuous progress and product improvement, manufacturer reserves the right to make changes without notice.

5600 Old Greenwood Road
Fort Smith, Arkansas 72908 • Friedrich.com

125 Edgeware Road, Unit 1
Brampton, Ontario • L6Y 0P5