



**FRIEDRICH**

1 8 8 3

**Friedrich® Resolute™ Line  
Packaged Heat Pump**



**RHPH Standard Efficiency Series**

Nominal Sizes 15 and 20 Ton

[52.8 and 70.3 kW]

ASHRAE 90.1-2019 Compliant Models



## TABLE OF CONTENTS

Unit Features & Benefits .....	3-8
Model Number Identification .....	9
Options .....	10
Selection Procedure .....	11
General Data.....	12-15
General Data Notes .....	16
Gross Systems Performance Data .....	17-20
Airflow Performance .....	21-24
Electrical Data.....	25-28
Electric Heater Kits .....	29-34
Dimensional Data .....	35-38
Accessories .....	39-48
Mechanical Specifications .....	49-55
Limited Warranty .....	56



## RHPH STANDARD FEATURES INCLUDE:

- Unit is assembled, wired, charged with R-410A HFC refrigerant and run tested at the factory.
- Scroll compressors with internal line break overload and high-pressure protection.
- Two independent refrigerant circuits each with a scroll compressor provide two stage cooling/heating operation.
- TXV refrigerant metering system on each circuit.
- High Pressure and Low Pressure/Loss of charge protection standard on all models.
- Solid Core liquid line filter drier on each circuit.
- Each evaporator and condenser coil is constructed as a single slab to facilitate easy cleaning for maintaining high efficiencies.
- Cooling operation up to 125 degree F ambient.
- Foil faced insulation encapsulated throughout entire unit minimizes airborne fibers from the air stream.
- Hinged major access door with heavy-duty gasketing with 1/4 latches and door retainers are optional.
- Slide Out Indoor fan assembly for added service convenience.
- Powder Paint Finish meets ASTM B117 G90 galvanized steel coated on each side for maximum protection.
- Base pan with drain supply and return opening for superior water management.
- Convertible airflow – vertical downflow or horizontal sideflow.
- Forkable base rails for easy handling and lifting.
- Single point electrical connections.
- Internally sloped slide out condensate pan conforms to ASHRAE 62 standards.
- High performance belt drive motor with variable pitch pulleys and quick adjust belt system.
- Permanently lubricated evaporator, and condenser motors.
- Condenser motors are internally protected, totally enclosed with shaft down design.
- 2 inch filter standard with slide out design.
- 24 volt control system with resettable circuit breakers.
- Colored and labeled wiring.
- Copper tube/Aluminum Fin coils.
- Supplemental electric heat provides 100% efficient heating.
- Variable Frequency Drive (VFD).
- MERV 8 and MERV 13 filters available as an option.
- Compliant with ASHRAE 90.1-2019 and California Title 24.

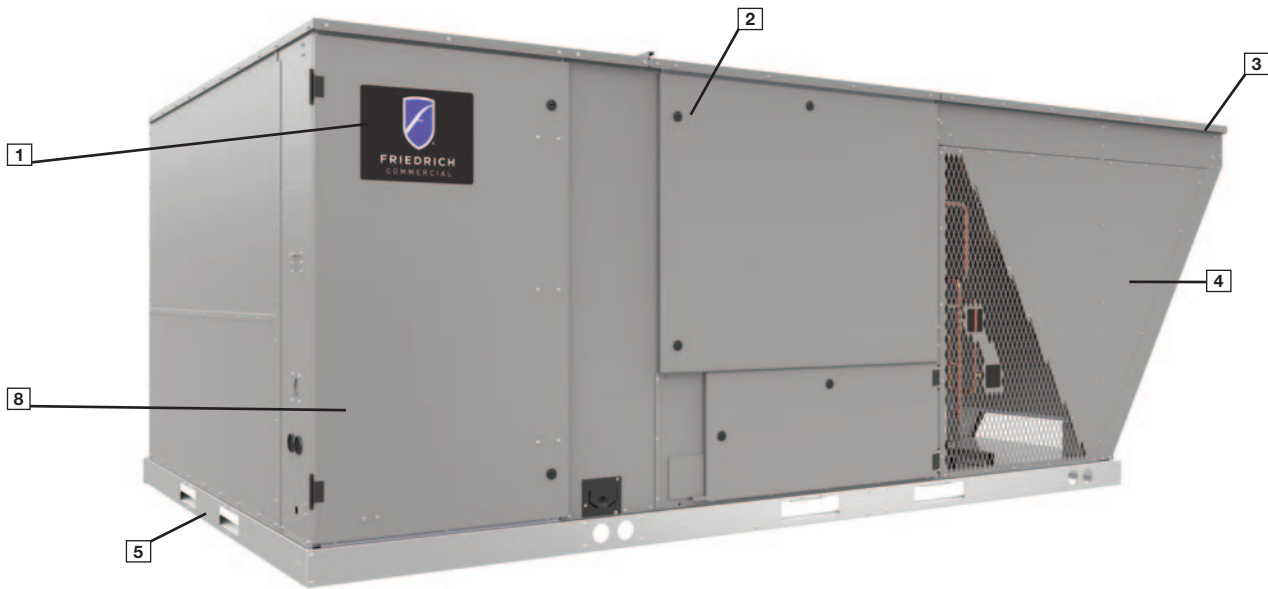

### Cabinet and Foundation

Resolute™ Packaged equipment is designed from the ground up with the latest features and benefits required to compete in today’s market. The clean design stands alone in the industry and is a testament to the quality, reliability, ease of installation and serviceability that goes into each unit. Outwardly, the large Friedrich® label (1) identifies the brand to the customer. The sheet-metal cabinet (2) uses nothing less than 20-gauge material for structural components with an underlying coat of G90. To ensure the leak-proof integrity of these units, the design utilizes a top with a 1/8 drip lip (3), gasket-protected panels and screws. (4) The outdoor coil is slanted to protect from hail. Every Friedrich packaged unit uses the toughest finish in the industry, using electro deposition baked-on enamel tested to withstand a rigorous 1000-hour salt spray test, per ASTM B117.

### Base Pan and Foundation

Anything built to last must start with the right foundation. In this case, the foundation is 14-gauge, commercial-grade, full-perimeter base rails (5), which integrate fork slots and rigging holes to save set-up time on the job site. The base pan is stamped, which forms a 1-1/8 flange around the supply and return cover and has eliminated the worry of water entering the conditioned space (6). The drainpan (7) is made of plastic that resists the growth of harmful bacteria and is sloped for the latest IAQ benefits. Furthermore, the drain pan slides out for easy cleaning. The insulation has been placed on the underside of the basepan, removing areas that would allow for potential moisture accumulation, which can facilitate growth of harmful bacteria. All insulation is secured with both adhesive and mechanical fasteners, and all edges are hidden.

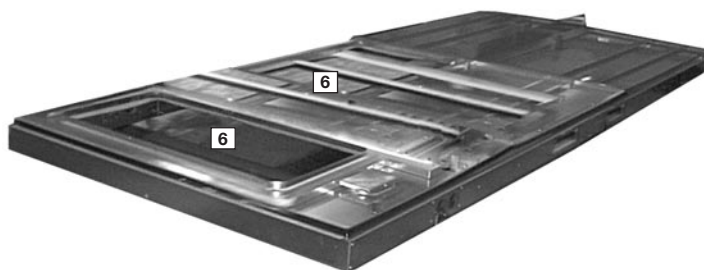

### Test Standards

During development, each unit was tested to U.L. 1995, AHRI 340/360 and other Friedrich-required reliability tests. Friedrich adheres to stringent ISO 9001:2015 quality procedures, and each unit bears the U.L. and AHRI certification labels located on the unit nameplate (8). Contractors can rest assured that when a Friedrich packaged unit arrives at the job, it is ready to go with a factory charge and quality checks.

### Easy Access

Access to all major compartments is from the front of the unit, including the filter and electrical compartment, blower compartment, heating section, and outdoor section. Each panel is permanently embossed with the compartment name (control/filter access, blower access and furnace access).

### Charging Charts, Wiring Diagrams and Labels

Electrical and filter compartment access is through a large, hinged-access panel with 1/4 turn latches. On the outside of the panel is the unit nameplate, which contains the model and serial number, electrical data and other important unit information.

The unit charging chart is located on the inside of the electrical and filter compartment door. Electrical wiring diagrams are found on the control box cover, which allows contractors to move them to more readable locations. To the right of the control box the model and serial number can be found. Having this information on the inside will assure model identification for the life of the product. The production line quality test assurance label is also placed in this location (9). The two-inch throwaway filters (10) are easily removed on a tracked system for easy replacement.

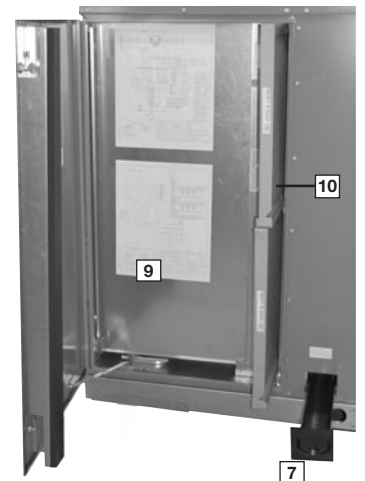



### Control Box

In the control compartment, components are organized centrally for ease of trouble-shooting (11). Wiring is numbered on each end of the termination and color-coded to match the wiring diagram. The control transformer has a low voltage circuit breaker that trips if a low voltage electrical short occurs. There is a blower contactor and contactor for each compressor.

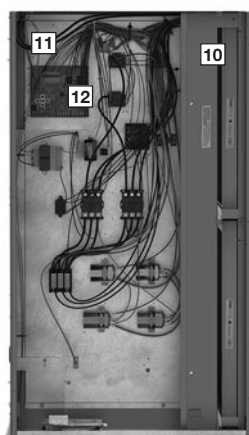

### Defrost Control

Enhanced feature demand defrost control has high and low pressure control inputs with unique pressure switch logic built into the micro-processor to provide compressor and system protection without nuisance lock-outs. LED's on the defrost control provide diagnostic information for service personnel (12).

### Convenience Outlet and Disconnect Switch

For added convenience in the field, a factory-installed convenience outlet (13) is available. Low and High voltage can enter either from the side or through the base. Low-voltage connections are made through the low-voltage terminal strip. For ease of access, the U.L.-required low voltage barrier can be temporarily removed for low-voltage termination and then reinstalled. The high-voltage connection is terminated at the high voltage terminal block. The suggested mounting for the field-installed disconnect is on the exterior side of the electrical control box.



### Blower Assembly

The blower compartment is to the right of the control box and can be accessed by 1/4 turn latches. To allow easy maintenance of the blower assembly, the entire assembly easily slides out by removing four #10 screws from the blower assembly. The adjustable motor pulley (14) can easily be adjusted by loosening the bolts on either side of the motor mount. Removing the bolts allows for easy removal of the blower pulley by pushing the blower assembly up to loosen the belt. Once the pulley is removed, the motor sheave can be adjusted to the desired number of turns, ranging from 0 to 6 turns open. Where the demands for the job require high static, Friedrich® has high-static drives available that deliver nominal airflow up to 2 inches of static. By referring to the airflow performance tables listed in the installation instructions, proper static pressure and CFM requirements can be dialed in. The scroll housing (15) and blower scroll provide quiet and efficient airflow. The blower sheave is secured by an H bushing which firmly secures the pulley to the blower shaft for years of trouble-free operation. The H bushing allows for easy removal of the blower pulley from the shaft, as opposed to the use of a set screw, which can score the shaft, creating burrs that make blower-pulley removal difficult.

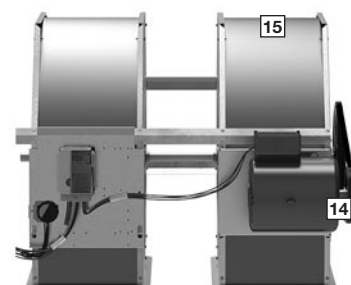

## Evaporator Coil

Inside the blower compartment the interlaced evaporator can also be viewed. The evaporator uses enhanced fin technology for maximum heat transfer.

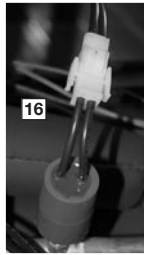

## Freezestats

Also in the blower compartment, the optional freezestats (16) protect the compressors if the evaporator gets too cold (below freezing) due to low airflow. The optional freezestats clip on the suction lines near the indoor coil and connect to the low voltage circuit with the use of polarized plugs and removable jumper for easy field or factory installation.

## Wire Routing

Wiring throughout the unit is neatly bundled and routed. Where wire harnesses go through the condenser bulkhead or blower deck, a molded wire harness assembly (17) provides an air-tight and water-tight seal, and provides strain relief. Care is also taken to tuck raw edges of insulation behind sheet metal to improve indoor air quality.

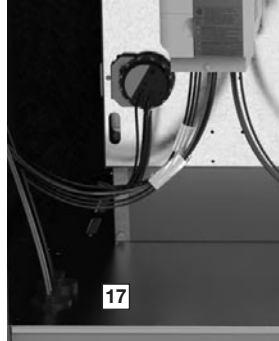

## Heater Compartment

The auxillary heating compartment contains the latest electric furnace technology on the market. The 100% efficient electric furnace can be factory-installed or easily field-installed. Built with ease-of-installation in mind, the electric furnace is completely wired up for slide-in, plug-and-play installation in the field. With choices that range from 18 to 72kW, the contractor is assured to get the correct amount of heating output to meet the designed heating load.

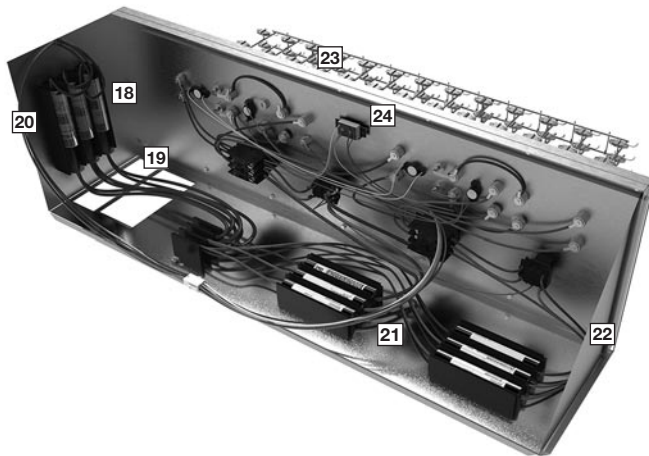

Power hook-up in the field is easy with single-point wiring to a terminal block (18) and a polarized plug for the low-voltage connection (19). The electric furnace comes with fuses for the unit (20) and for the electric furnace (21). For increased serviceability, the entire heat kit section is an assembly that can be removed in one piece. (22). The electric heating elements are of a wound-wire construction (23) and isolated with ceramic bushings. The limit switch (24) protects the design from over-temperature conditions.

## Compressor

The compressor compartment houses the heartbeat of the unit. The scroll compressor (25) is known for its long life, and for reliable, quiet, and efficient operation. The suction and discharge lines are designed with shock loops (26) to absorb the strain and stress that the starting torque, steady state operation, and shut down cycle impose on the refrigerant tubing. Each compressor and circuit is independent for built-in redundancy, and each circuit is clearly marked throughout the system. Each unit has two stages of efficient cooling operation, first stage is approximately 50% of second stage.

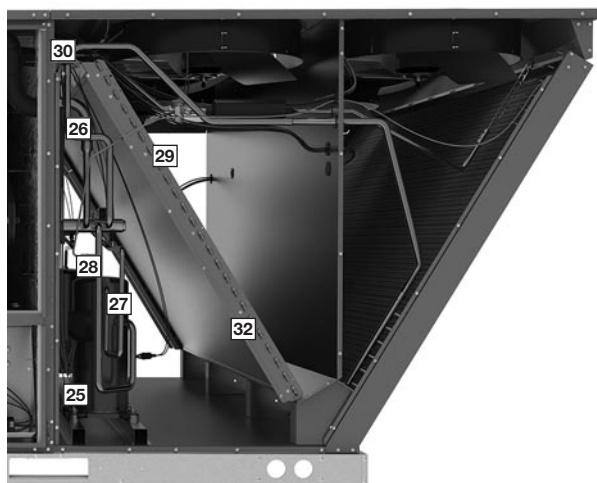

### External Gauge Ports

In the outdoor section are the external gauge ports (27). With the gauge ports mounted externally, an accurate diagnosis of system operation can be performed quickly and easily. Also located in this area are the refrigerant safety devices: the low-pressure switches (28), and the high-pressure switches (29). The high-pressure switches will shut off the compressors if pressures exceeding 610 psig are detected as may occur if the outdoor fan motor fails. The low pressure switches shut off the compressors if low pressure is detected due to loss of refrigerant charge. Each factory-installed option is brazed into the appropriate high or low side and wired appropriately. The optional low ambient controls (30) screw to schrader valves on the discharge line. The low-ambient controls allow cooling mode operation of the compressors down to 0 degrees ambient temperature by cycling the outdoor fans based on discharge pressure.

### Condenser Fans

The condenser fan motor (31) can easily be accessed and maintained by removing the protective fan grille. The polarized plug connection allows the motor to be changed quickly and eliminates the need to snake wires through the unit.

### Condenser Technology

The outdoor coil uses the latest enhanced fin design (32) for the most effective method of heat transfer. The outdoor coil is slanted to protect the unit from hail.



### Economizers and Dampers

Each unit is designed for both downflow or horizontal applications (33) for job configuration flexibility. The return air compartment can also contain an economizer (34). Two models exist, one for downflow applications, and one for horizontal applications. Each unit is pre-wired for the economizer to allow quick plug-in installation. The downflow economizer is also available as a factory-installed option. Power Exhaust is easily field-installed. The economizer, which provides free cooling when outdoor conditions are suitable and also provides fresh air to meet local requirements, comes standard with single enthalpy controls. The controls can be upgraded to dual enthalpy easily in the field. The direct drive actuator combined with gear drive dampers has eliminated the need for linkage adjustment in the field. The economizer control has a minimum position setpoint, an outdoor-air setpoint, a mix-air setpoint, and a CO<sub>2</sub> setpoint. Barometric relief is standard on all economizers. The power exhaust is housed in the barometric relief opening and is easily slipped in with a plug-in assembly.

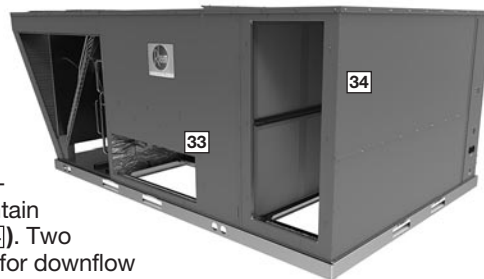

### Roofcurb

The Friedrich® roofcurb (35) is made for toolless assembly at the jobsite by inserting a pin into the hinged corners (36), which makes the assembly process quick and easy.

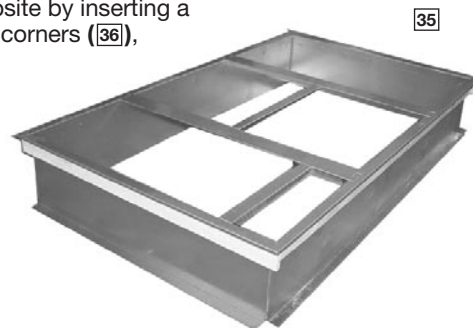

## ClearControl™

The optional ClearControl™ system consisting of a rooftop unit controller, temperature sensors, and pressure sensors, allows real-time monitoring and communication between rooftop units. The Rooftop Unit Controller (RTU-C) that is factory mounted and wired into the control panel. The RTU-C is a solid-state, micro-processor-based control board that provides flexible control and extensive diagnostics for all unit functions. The RTU-C, using proportional/integral control algorithms, performs specific unit functions that govern unit operation in response to zone conditions, system temperatures, system pressures, ambient conditions, and electrical inputs. The RTU-C features a 16 x 2 character LCD display and a five-button keypad for local configuration and direct diagnosis of the system (37). Features include a clogged filter switch (CFS), fan proving switch (FPS), return air temperature sensor (RAT), discharge air temperature sensor (DAT), and outdoor air temperature sensor (OAT). Freeze sensors (FS) are used in place of freeze stats to allow measurement of refrigerant suction line temperatures.

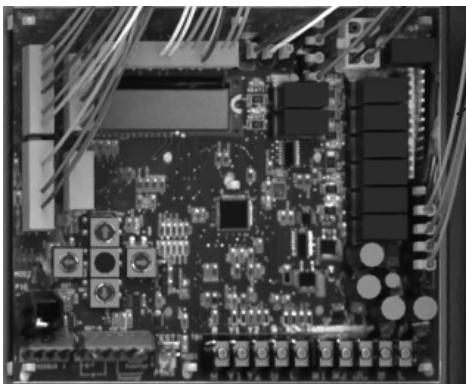

37

The unit with the RTU-C is specifically designed to be applied in four distinct applications:

**1. BACnet Communication** — The unit is compatible with a third party building management system that supports the BACnet Application Specific Controller device profile, with the use of a field installed BACnet Communication Module. The BACnet Communication Module plugs onto the unit RTU-C controller and allows communication between the RTU-C and the BACnet MSTP network. A zone sensor, a BACnet network zone sensor, a BACnet thermostat, or DDC controller may be used to send the zone temperature or thermostat demands to the RTU-C. The BACnet Communication Module is compatible with MSTP EIA-485 daisy chain networks communicating at 38.4 bps. It is compatible with twisted pair, shielded cables.

**2. LonWorks Communication** — The unit is compatible with a third party building management system that supports the LonMark Space Comfort Controller (SCC) functional profile or LonMark Discharge Air Controller (DAC) functional profile. This is accomplished with a field installed LonMark communication module. The LonMark Communication Module plugs onto the RTU-C controller and allows communication between the RTU-C and a LonWorks network. A zone sensor, a LonTalk network zone sensor, or a LonTalk thermostat or DDC controller may be used to send the zone temperature or thermostat demands to the RTU-C. The LonMark Communication Module utilizes an FTT-10A free topology transceiver communicating at 78.8 kbps. It is compatible with Echelon qualified, twisted pair cable, Belden 8471, or NEMA Level 4 cables. The module can communicate up to 1640 feet with no repeater. The LonWorks limit of 64 nodes per segment applies to this device.

**3. 24V Thermostat Compatibility** — The unit is compatible with a programmable 24 volt thermostat. Connections are made via conventional thermostat screw terminals. Extensive unit status and diagnostics are displayed on the LCD screen of the RTU-C.

**4. Zone Sensor Compatibility** — The unit is compatible with a zone sensor and a mechanical or solid state time clock connected to the RTU-C. Extensive unit status and diagnostics are displayed on the LCD screen of the RTU-C.

## ComfortAlert®

A factory or field installed Comfort Alert® module is available for power phase-monitoring protection and additional compressor diagnostics. The alarms can be displayed on the RTU-C display or through the (BAS) network.

## Variable Frequency Drive

The supply fan Variable Frequency Drive (VFD) (38) optimizes energy usage year round by providing a lower speed for first stage cooling operation, improving IEER's over the conventional constant fan system. Operating in the constant fan mode at the reduced speed can use as little as 1/5 of the energy of a conventional constant fan system. Also, by operating at a lower speed on first stage cooling, up to 51% more moisture is removed, improving comfort during low load operation. The VFD supply fan meets California Title 24 and ASHRAE 90.1-2016 requirements for multi blower speed control. VFD also ramps up to the desired speed, reducing stress on the supply fan components and noise from a sudden inrush of air. Because the airflow is cut in half during first stage cooling and constant fan operation, noise is much less during these modes of operation.

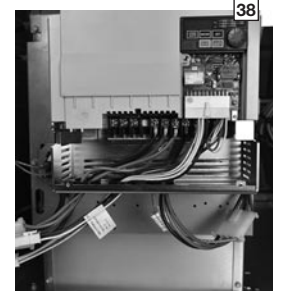

38



**R** **HP** **H** **2** **T** **180** **A** **C** **F** **00** **2** **B** **A** **\*\*\*\***  
**1** **23** **4** **5** **6** **789** **10** **11** **12** **13 14** **15** **16** **17** **18 19 20 21**

---

**1—Brand**

R = Friedrich®

**2, 3—Unit Type**

HP = Packaged HP

**4—Cabinet Type**

H = Large Commercial

**5—Cooling Stages**

2 = 2 Stages of Cooling

**6—Efficiency Tier**

T = Standard Efficiency

**7, 8, 9—Capacity**

180 = 15 ton

240 = 20 ton

**10—Major Series**

A = 410A

**11—Voltage**

C = 3 phase 208-230/60

D = 3 phase 460/60

Y = 3 phase 575/60

**12—Drive**

F = Belt Drive-VFD Low

G = Belt Drive-VFD Medium

H = Belt Drive-VFD High

**13, 14—Supplemental Heat Capacity**

00 = No Heat

20 = 20kw

40 = 40kw

60 = 60kw

75 = 75kw

**15—Supplemental Heat Configuration**

0 = No heat

1 = 1-Stage

2 = 2-Stage

**16—Control**

B = Core Command™ & Phase Monitor

C = Clear Control™ & Phase Monitor

D = Clear Control™ & Comfort Alert®

**17 —Minor Series**

A = 1st design

**18, 19, 20, 21—Option Code**

See next page

## FACTORY INSTALLED OPTION CODES FOR RHPH

18				19			20			21	
LV = Louver protection				NP = Non-Powered Convenience Outlet			EC = Economizer			M8 = MERV 8 Filter	
HA = Hinged Access				LF = Low Ambient & Freeze Stat			SS = Supply & Return Smoke			M13 = MERV 13 Filter	
							RS = Return Smoke				
OPTION CODE CHARACTER HIGHLIGHTED											
OPT				OPT			OPT			OPT	
<b>C</b>	HA			<b>A</b>	None		<b>0</b>	None		<b>A</b>	None
<b>D</b>	LV	HA		<b>B</b>	LF		<b>1</b>	EC		<b>D</b>	M8
				<b>C</b>	NP		<b>2</b>	RS		<b>G</b>	M13
				<b>D</b>	LF	NP	<b>3</b>	EC	RS		
							<b>4</b>	SS			
							<b>5</b>	EC	SS		

Example: RHPH2T 180ACG000BAXXXX (where XXXX is factory installed options)

Example: No Options

RHPH2T180ACG000BACA0A

Example: No options except factory installed economizer

RHPH2T180ACG000BACA1A

Example: Options with low ambient/freezestat and no factory installed economizer

RHPH2T180ACG000BACBOA

Example: Options same as above with factory installed economizer

RHPH2T180ACG000BACB1A

To select an RHPH Cooling and Heating unit to meet a job requirement, follow this procedure, with example, using data supplied in this specification sheet.

### 1. DETERMINE COOLING AND HEATING REQUIREMENTS AND SPECIFIC OPERATING CONDITIONS FROM PLANS AND SPECS.

**Example:**

Voltage—	460 V — 3 Phase — 60 Hz
Total Cooling Capacity—	170,000 BTUH [49.8 kW]
Sensible Cooling Capacity—	140,000 BTUH [41.0 kW]
Heating Capacity—	140,000 BTUH [41.0 kW]
*Condenser Entering Air—	95°F [35.0 °C] DB
*Evaporator Mixed Air Entering—	67°F [19.4 °C] WB 78°F [25.6 °C] DB
*Winter Entering Air (for Heating)	20°F [-6.6 °C] DB
*Indoor Air Flow (vertical)—	6,000 CFM [3020 L/s]
External Static Pressure—	1.2 in. WG [.30 kPa]

### 2. SELECT UNIT TO MEET COOLING REQUIREMENTS.

Since total cooling is within the range of a nominal 15 ton [52.7 kW] unit, use the cooling performance table at 95°F [35.0 °C] DB condenser inlet air. Interpolate between 6025 CFM [2843 L/s] and 4800 CFM [2265 L/s] to determine total and sensible capacity and Depression Ratio for inlet air at 6000 CFM [2843 L/s] indoor air flow (table basis):

Interpolation Formula:

$$BTUH_1 + \left[ (CFM - CFM_1) \times \left( \frac{BTUH_2 - BTUH_1}{CFM_2 - CFM_1} \right) \right] = BTUH$$

Total Cooling Capacity=

$$177,900 + \left[ (6,000 - 6,025) \times \left( \frac{169,600 - 177,900}{4,800 - 6,025} \right) \right] = 177,731 \text{ BTUH}$$

Total Cooling Capacity = 177,731 BTUH [52.1 kW]

Sensible Cooling Capacity = 149,535 BTUH [43.8 kW]

DR = 0.018

When the entering dry bulb temperature (dbE) is not 80°F [26.7°C], the sensible capacity needs to be adjusted.

Note: total capacity is unaffected

Sensible Capacity Depression Formula:

$$Cap_{sensible} + [1.10 \times CFM \times (1 - DR) \times (dbE - 80)]$$

$$149,535 + [1.10 \times 6,000 \times (1 + 0.018) \times (78 - 80)]$$

$$\text{Sensible Cooling Capacity} = 136,097 \text{ BTUH [39.9 kW]}$$

### 3. DETERMINE BLOWER SPEED AND BHP TO MEET SYSTEM DESIGN.

Total ESP (external static pressure) per the spec of 1.2 in WG [.30 kPa] includes the system duct and grilles. Add from the table “Component Air Resistance”, 0.08 in. WG [.02 kPa] for wet coil and 0.05 in. WG [.01 kPa] for downflow to get an ESP of 1.33 in. WG [.33 kPa]. Using the “Airflow Performance Table”, at the specified 6,000 CFM and 1.33 in. WG [.33 kPa] ESP, determine blower motor wattage.

RPM = 785

Motor Wattage = 2731 W

DRIVE = G

### 4. CALCULATE INDOOR BLOWER BTUH HEAT EFFECT FROM MOTOR BHP IN STEP 3.

Assuming an average of 85% motor efficiency, determine the amount of heat generated by the blower motor at the specified CFM and ESP by dividing the BHP by the motor efficiency and solving for the difference. Convert this value from Watt to BTUH, multiplying by 3.41 BTUH/Watt:

Motor Wattage = 2731 W

AVG MOTOR EFFICIENCY = 85%

INDOOR BLOWER MOTOR HEAT =

$$\left[ \left( \frac{\text{Watt}}{0.85} - \text{Watt} \right) \right] \times 3.41$$

$$= [(2731/0.85) - 2731] \times 3.41 = 1643 \text{ BTUH [.4 kW]}$$

### 5. CALCULATE THE NET COOLING CAPACITIES

Net cooling capacities can be calculated by subtracting the motor heat from the gross cooling capacities.

Net Total Capacity = Gross Total Capacity – Indoor Blower Motor Heat

$$= 177,731 - 1,643 = 176,088 \text{ BTUH [51.6 kW]}$$

Net Sensible Capacity = Gross Sensible Capacity – Indoor Blower Motor Heat

$$= 136,097 - 1,643 = 134,454 \text{ BTUH [39.4 kW]}$$

### 6. SELECT UNIT HEATING CAPACITY

Determine if an auxiliary electric heater is required to meet the heat requirements. Use the heating performance table at 20°F DB Winter Entering Air to determine the heat pump heating capacity. Interpolate between 6025 CFM [2843 L/s] and 4,800 CFM [2265 L/s] to determine the capacity at 6,000 CFM [2831 L/s].

$$\text{Heating Capacity} = 97,809 \text{ BTUH [28.6 kW]}$$

The required heating capacity is 140,000 BTUH [41.0 kW]. An additional electric heater is required to meet this heating requirement. From “Heater Kit” Table, select kW to meet heating capacity requirement; multiply kW by 3412 to convert to BTUH.

Use 20 kW Heater Kit

Heater Kit Model:  
RXJJCE20D+

Heater Kit Capacity:  
68,242 BTUH [19.9 kW]

Add Heating Capacity and Indoor Blower Motor Heat (step 4) to Heater Kit Capacity to get net total heating capacity:  
68,242 + 97,809 + 1,643 = 167,694 BTUH [49.1 kW]

### 7. CHOOSE MODEL RHPH2T180A with 20kW Electric Heater

[ ] Designates Metric Conversions

## NOM. SIZES 15 TON [52.8 kW] ASHRAE 90.1-2019 COMPLIANT MODELS

Model RHPH2T- Series	180ACF	180ACG	180ADF	180ADG
<b>Cooling Performance<sup>A</sup></b>				<b>CONTINUED</b> →
Gross Cooling Capacity Btu [kW]	178,000 [52.15]	178,000 [52.15]	178,000 [52.15]	178,000 [52.15]
EER	10.6	10.6	10.6	10.6
IEER <sup>B</sup>	13.5	13.5	13.5	13.5
Nominal CFM/AHRI Rated CFM [L/s]	6000/6450 [2831/3044]	6000/6450 [2831/3044]	6000/6450 [2831/3044]	6000/6450 [2831/3044]
AHRI Net Cooling Capacity Btu [kW]	172,000 [50.4]	172,000 [50.4]	172,000 [50.4]	172,000 [50.4]
Net Sensible Capacity Btu [kW]	144,000 [42.19]	144,000 [42.19]	144,000 [42.19]	144,000 [42.19]
Net Latent Capacity Btu [kW]	28,000 [8.2]	28,000 [8.2]	28,000 [8.2]	28,000 [8.2]
Net System Power [kW]	16.71	16.71	16.71	16.71
<b>Heating Performance (Heat Pumps)</b>				
High Temp. Btuh [kW] Rating	162,000 [47.47]	162,000 [47.47]	162,000 [47.47]	162,000 [47.47]
System Power KW / COP	13.66/3.3	13.66/3.3	13.66/3.3	13.66/3.3
Low Temp. Btuh [kW] Rating	94,000 [27.54]	94,000 [27.54]	94,000 [27.54]	94,000 [27.54]
System Power KW / COP	12.48/2.1	12.48/2.1	12.48/2.1	12.48/2.1
<b>Compressor</b>				
No./Type	2/Scroll	2/Scroll	2/Scroll	2/Scroll
<b>Outdoor Sound Rating (dB)<sup>C</sup></b>				
	91	91	91	91
<b>Outdoor Coil—Fin Type</b>				
Tube Type	Louvered	Louvered	Louvered	Louvered
Tube Size in. [mm]	Rifled	Rifled	Rifled	Rifled
Tube Size in. [mm]	0.375 [9.5]	0.375 [9.5]	0.375 [9.5]	0.375 [9.5]
Face Area sq. ft. [sq. m]	53.3 [4.95]	53.3 [4.95]	53.3 [4.95]	53.3 [4.95]
Rows / FPI [FPcm]	1 / 22 [9]	1 / 22 [9]	1 / 22 [9]	1 / 22 [9]
Refrigerant Control	TX Valves	TX Valves	TX Valves	TX Valves
<b>Indoor Coil—Fin Type</b>				
Tube Type	Louvered	Louvered	Louvered	Louvered
Tube Type	Rifled	Rifled	Rifled	Rifled
Tube Size in. [mm]	0.375 [9.5]	0.375 [9.5]	0.375 [9.5]	0.375 [9.5]
Face Area sq. ft. [sq. m]	26.67 [2.48]	26.67 [2.48]	26.67 [2.48]	26.67 [2.48]
Rows / FPI [FPcm]	2 / 18 [7]	2 / 18 [7]	2 / 18 [7]	2 / 18 [7]
Refrigerant Control	TX Valves	TX Valves	TX Valves	TX Valves
Drain Connection No./Size in. [mm]	1/1 [25.4]	1/1 [25.4]	1/1 [25.4]	1/1 [25.4]
<b>Outdoor Fan—Type</b>				
Propeller	Propeller	Propeller	Propeller	Propeller
No. Used/Diameter in. [mm]	4/24 [609.6]	4/24 [609.6]	4/24 [609.6]	4/24 [609.6]
Drive Type/No. Speeds	Direct/1	Direct/1	Direct/1	Direct/1
CFM [L/s]	6000 [2831]	6000 [2831]	6000 [2831]	6000 [2831]
No. Motors/HP	4 at 1/3 HP	4 at 1/3 HP	4 at 1/3 HP	4 at 1/3 HP
Motor RPM	1075	1075	1075	1075
<b>Indoor Fan—Type</b>				
FC Centrifugal	FC Centrifugal	FC Centrifugal	FC Centrifugal	FC Centrifugal
No. Used/Diameter in. [mm]	2/18x9 [457x229]	2/18x9 [457x229]	2/18x9 [457x229]	2/18x9 [457x229]
Drive Type/No. Speeds	Belt (Adjustable)	Belt (Adjustable)	Belt (Adjustable)	Belt (Adjustable)
No. Speeds	Single	Single	Single	Single
No. Motors	1	1	1	1
Motor HP	3	5	3	5
Motor RPM	1725	1755	1725	1755
Motor Frame Size	56	184	56	184
<b>Filter—Type</b>				
Disposable	Disposable	Disposable	Disposable	Disposable
Furnished	Yes	Yes	Yes	Yes
(NO.) Size Recommended in. [mm x mm x mm]	(8)2x25x20 [51x635x508]	(8)2x25x20 [51x635x508]	(8)2x25x20 [51x635x508]	(8)2x25x20 [51x635x508]
<b>Refrigerant Charge Oz. (Sys. 1/Sys. 2) [g]</b>				
	204/200 [5783/5670]	204/200 [5783/5670]	204/200 [5783/5670]	204/200 [5783/5670]
<b>Weights</b>				
Net Weight lbs. [kg]	1826 [828]	1855 [841]	1958 [888]	1987 [901]
Ship Weight lbs. [kg]	1926 [874]	1955 [887]	2058 [934]	2087 [947]

See Page 16 for Notes.

[ ] Designates Metric Conversions

## NOM. SIZES 15 TON [52.8 kW] ASHRAE 90.1-2019 COMPLIANT MODELS

Model RHPH2T- Series	180AYF	180AYG	240ACF	240ACG
<b>Cooling Performance<sup>A</sup></b>				
	<b>CONTINUED →</b>			
Gross Cooling Capacity Btu [kW]	178,000 [52.15]	178,000 [52.15]	246,000 [72.08]	246,000 [72.08]
EER	10.6	10.6	9.5	9.5
IEER <sup>B</sup>	13.5	13.5	12.5	12.5
Nominal CFM/AHRI Rated CFM [L/s]	6000/6450 [2831/3044]	6000/6450 [2831/3044]	8000/8200 [3775/3870]	8000/8200 [3775/3870]
AHRI Net Cooling Capacity Btu [kW]	172,000 [50.4]	172,000 [50.4]	240,000 [70.32]	240,000 [70.32]
Net Sensible Capacity Btu [kW]	144,000 [42.19]	144,000 [42.19]	188,000 [55.08]	188,000 [55.08]
Net Latent Capacity Btu [kW]	28,000 [8.2]	28,000 [8.2]	52,000 [15.24]	52,000 [15.24]
Net System Power [kW]	16.71	16.71	22.86	22.86
<b>Heating Performance (Heat Pumps)</b>				
High Temp. Btuh [kW] Rating	162,000 [47.47]	162,000 [47.47]	236,000 [69.15]	236,000 [69.15]
System Power KW / COP	13.66/3.3	13.66/3.3	19.66/3.3	19.66/3.3
Low Temp. Btuh [kW] Rating	94,000 [27.54]	94,000 [27.54]	136,000 [39.85]	136,000 [39.85]
System Power KW / COP	12.48/2.1	12.48/2.1	17.63/2.1	17.63/2.1
<b>Compressor</b>				
No./Type	2/Scroll	2/Scroll	2/Scroll	2/Scroll
<b>Outdoor Sound Rating (dB)<sup>C</sup></b>				
	91	91	91	91
<b>Outdoor Coil—Fin Type</b>				
Tube Type	Louvered	Louvered	Louvered	Louvered
Tube Size in. [mm]	Rifled	Rifled	Rifled	Rifled
Tube Size in. [mm]	0.375 [9.5]	0.375 [9.5]	0.375 [9.5]	0.375 [9.5]
Face Area sq. ft. [sq. m]	53.3 [4.95]	53.3 [4.95]	53.3 [4.95]	53.3 [4.95]
Rows / FPI [FPcm]	1 / 22 [9]	1 / 22 [9]	2 / 18 [7]	2 / 18 [7]
Refrigerant Control	TX Valves	TX Valves	TX Valves	TX Valves
<b>Indoor Coil—Fin Type</b>				
Tube Type	Louvered	Louvered	Louvered	Louvered
Tube Type	Rifled	Rifled	Rifled	Rifled
Tube Size in. [mm]	0.375 [9.5]	0.375 [9.5]	0.375 [9.5]	0.375 [9.5]
Face Area sq. ft. [sq. m]	26.67 [2.48]	26.67 [2.48]	26.67 [2.48]	26.67 [2.48]
Rows / FPI [FPcm]	2 / 18 [7]	2 / 18 [7]	3 / 13 [5]	3 / 13 [5]
Refrigerant Control	TX Valves	TX Valves	TX Valves	TX Valves
Drain Connection No./Size in. [mm]	1/1 [25.4]	1/1 [25.4]	1/1 [25.4]	1/1 [25.4]
<b>Outdoor Fan—Type</b>				
Propeller	Propeller	Propeller	Propeller	Propeller
No. Used/Diameter in. [mm]	4/24 [609.6]	4/24 [609.6]	6/24 [609.6]	6/24 [609.6]
Drive Type/No. Speeds	Direct/1	Direct/1	Direct/1	Direct/1
CFM [L/s]	6000 [2831]	6000 [2831]	6000 [2831]	6000 [2831]
No. Motors/HP	4 at 1/3 HP	4 at 1/3 HP	6 at 1/3 HP	6 at 1/3 HP
Motor RPM	1075	1075	1075	1075
<b>Indoor Fan—Type</b>				
FC Centrifugal	FC Centrifugal	FC Centrifugal	FC Centrifugal	FC Centrifugal
No. Used/Diameter in. [mm]	2/18x9 [457x229]	2/18x9 [457x229]	2/18x9 [457x229]	2/18x9 [457x229]
Drive Type/No. Speeds	Belt (Adjustable)	Belt (Adjustable)	Belt (Adjustable)	Belt (Adjustable)
No. Speeds	Single	Single	Single	Single
No. Motors	1	1	1	1
Motor HP	3	5	5	7 1/2
Motor RPM	1725	1755	1755	1760
Motor Frame Size	56	184	184	213
<b>Filter—Type</b>				
Disposable	Disposable	Disposable	Disposable	Disposable
Furnished	Yes	Yes	Yes	Yes
(NO.) Size Recommended in. [mm x mm x mm]	(8)2x25x20 [51x635x508]	(8)2x25x20 [51x635x508]	(8)2x25x20 [51x635x508]	(8)2x25x20 [51x635x508]
<b>Refrigerant Charge Oz. (Sys. 1/Sys. 2) [g]</b>				
	204/200 [5783/5670]	204/200 [5783/5670]	340/328 [9639/9299]	340/328 [9639/9299]
<b>Weights</b>				
Net Weight lbs. [kg]	1826 [828]	1855 [841]	1865 [846]	1894 [859]
Ship Weight lbs. [kg]	1926 [874]	1955 [887]	1965 [891]	1994 [904]

See Page 16 for Notes.

[ ] Designates Metric Conversions

## NOM. SIZES 15 TON [52.8 kW] ASHRAE 90.1-2019 COMPLIANT MODELS

Model RHPH2T- Series	240ACH	240ADF	240ADG	240ADH
<b>Cooling Performance<sup>A</sup></b>				<b>CONTINUED</b> →
Gross Cooling Capacity Btu [kW]	246,000 [72.08]	246,000 [72.08]	246,000 [72.08]	246,000 [72.08]
EER	9.5	9.5	9.5	9.5
IEER <sup>B</sup>	12.5	12.5	12.5	12.5
Nominal CFM/AHRI Rated CFM [L/s]	8000/8200 [3775/3870]	8000/8200 [3775/3870]	8000/8200 [3775/3870]	8000/8200 [3775/3870]
AHRI Net Cooling Capacity Btu [kW]	240,000 [70.32]	240,000 [70.32]	240,000 [70.32]	240,000 [70.32]
Net Sensible Capacity Btu [kW]	188,000 [55.08]	188,000 [55.08]	188,000 [55.08]	188,000 [55.08]
Net Latent Capacity Btu [kW]	52,000 [15.24]	52,000 [15.24]	52,000 [15.24]	52,000 [15.24]
Net System Power [kW]	22.86	22.86	22.86	22.86
<b>Heating Performance (Heat Pumps)</b>				
High Temp. Btuh [kW] Rating	236,000 [69.15]	236,000 [69.15]	236,000 [69.15]	236,000 [69.15]
System Power KW / COP	19.66/3.3	19.66/3.3	19.66/3.3	19.66/3.3
Low Temp. Btuh [kW] Rating	136,000 [39.85]	136,000 [39.85]	136,000 [39.85]	136,000 [39.85]
System Power KW / COP	17.63/2.1	17.63/2.1	17.63/2.1	17.63/2.1
<b>Compressor</b>				
No./Type	2/Scroll	2/Scroll	2/Scroll	2/Scroll
<b>Outdoor Sound Rating (dB)<sup>C</sup></b>				
	91	91	91	91
<b>Outdoor Coil—Fin Type</b>				
Tube Type	Louvered	Louvered	Louvered	Louvered
Tube Size in. [mm]	Rifled	Rifled	Rifled	Rifled
Tube Size in. [mm]	0.375 [9.5]	0.375 [9.5]	0.375 [9.5]	0.375 [9.5]
Face Area sq. ft. [sq. m]	53.3 [4.95]	53.3 [4.95]	53.3 [4.95]	53.3 [4.95]
Rows / FPI [FPcm]	2 / 18 [7]	2 / 18 [7]	2 / 18 [7]	2 / 18 [7]
Refrigerant Control	TX Valves	TX Valves	TX Valves	TX Valves
<b>Indoor Coil—Fin Type</b>				
Tube Type	Louvered	Louvered	Louvered	Louvered
Tube Type	Rifled	Rifled	Rifled	Rifled
Tube Size in. [mm]	0.375 [9.5]	0.375 [9.5]	0.375 [9.5]	0.375 [9.5]
Face Area sq. ft. [sq. m]	26.67 [2.48]	26.67 [2.48]	26.67 [2.48]	26.67 [2.48]
Rows / FPI [FPcm]	3 / 13 [5]	3 / 13 [5]	3 / 13 [5]	3 / 13 [5]
Refrigerant Control	TX Valves	TX Valves	TX Valves	TX Valves
Drain Connection No./Size in. [mm]	1/1 [25.4]	1/1 [25.4]	1/1 [25.4]	1/1 [25.4]
<b>Outdoor Fan—Type</b>				
	Propeller	Propeller	Propeller	Propeller
No. Used/Diameter in. [mm]	6/24 [609.6]	6/24 [609.6]	6/24 [609.6]	6/24 [609.6]
Drive Type/No. Speeds	Direct/1	Direct/1	Direct/1	Direct/1
CFM [L/s]	6000 [2831]	6000 [2831]	6000 [2831]	6000 [2831]
No. Motors/HP	6 at 1/3 HP	6 at 1/3 HP	6 at 1/3 HP	6 at 1/3 HP
Motor RPM	1075	1075	1075	1075
<b>Indoor Fan—Type</b>				
	FC Centrifugal	FC Centrifugal	FC Centrifugal	FC Centrifugal
No. Used/Diameter in. [mm]	2/18x9 [457x229]	2/18x9 [457x229]	2/18x9 [457x229]	2/18x9 [457x229]
Drive Type/No. Speeds	Belt (Adjustable)	Belt (Adjustable)	Belt (Adjustable)	Belt (Adjustable)
No. Speeds	Single	Single	Single	Single
No. Motors	1	1	1	1
Motor HP	7 1/2	5	7 1/2	7 1/2
Motor RPM	1760	1755	1760	1760
Motor Frame Size	213	184	213	213
<b>Filter—Type</b>				
	Disposable	Disposable	Disposable	Disposable
Furnished	Yes	Yes	Yes	Yes
(NO.) Size Recommended in. [mm x mm x mm]	(8)2x25x20 [51x635x508]	(8)2x25x20 [51x635x508]	(8)2x25x20 [51x635x508]	(8)2x25x20 [51x635x508]
<b>Refrigerant Charge Oz. (Sys. 1/Sys. 2) [g]</b>				
	340/328 [9639/9299]	340/328 [9639/9299]	340/328 [9639/9299]	340/328 [9639/9299]
<b>Weights</b>				
Net Weight lbs. [kg]	1894 [859]	1865 [846]	1894 [859]	1894 [859]
Ship Weight lbs. [kg]	1994 [904]	1965 [891]	1994 [904]	1994 [904]

See Page 16 for Notes.

[ ] Designates Metric Conversions

## NOM. SIZES 15 TON [52.8 kW] ASHRAE 90.1-2019 COMPLIANT MODELS

Model RHPH2T- Series	240AYF	240AYG	240AYH
<b>Cooling Performance<sup>A</sup></b>			
Gross Cooling Capacity Btu [kW]	246,000 [72.08]	246,000 [72.08]	246,000 [72.08]
EER	9.5	9.5	9.5
IEER <sup>B</sup>	12.5	12.5	12.5
Nominal CFM/AHRI Rated CFM [L/s]	8000/8200 [3775/3870]	8000/8200 [3775/3870]	8000/8200 [3775/3870]
AHRI Net Cooling Capacity Btu [kW]	240,000 [70.32]	240,000 [70.32]	240,000 [70.32]
Net Sensible Capacity Btu [kW]	188,000 [55.08]	188,000 [55.08]	188,000 [55.08]
Net Latent Capacity Btu [kW]	52,000 [15.24]	52,000 [15.24]	52,000 [15.24]
Net System Power [kW]	22.86	22.86	22.86
<b>Heating Performance (Heat Pumps)</b>			
High Temp. Btuh [kW] Rating	236,000 [69.15]	236,000 [69.15]	236,000 [69.15]
System Power KW / COP	19.66/3.3	19.66/3.3	19.66/3.3
Low Temp. Btuh [kW] Rating	136,000 [39.85]	136,000 [39.85]	136,000 [39.85]
System Power KW / COP	17.63/2.1	17.63/2.1	17.63/2.1
<b>Compressor</b>			
No./Type	2/Scroll	2/Scroll	2/Scroll
<b>Outdoor Sound Rating (dB)<sup>C</sup></b>			
	91	91	91
<b>Outdoor Coil—Fin Type</b>			
Tube Type	Louvered	Louvered	Louvered
Tube Type	Rifled	Rifled	Rifled
Tube Size in. [mm]	0.375 [9.5]	0.375 [9.5]	0.375 [9.5]
Face Area sq. ft. [sq. m]	53.3 [4.95]	53.3 [4.95]	53.3 [4.95]
Rows / FPI [FPcm]	2 / 18 [7]	2 / 18 [7]	2 / 18 [7]
Refrigerant Control	TX Valves	TX Valves	TX Valves
<b>Indoor Coil—Fin Type</b>			
Tube Type	Louvered	Louvered	3 / 13 [5]
Tube Type	Rifled	Rifled	Rifled
Tube Size in. [mm]	0.375 [9.5]	0.375 [9.5]	0.375 [9.5]
Face Area sq. ft. [sq. m]	26.67 [2.48]	26.67 [2.48]	26.67 [2.48]
Rows / FPI [FPcm]	3 / 13 [5]	3 / 13 [5]	3 / 13 [5]
Refrigerant Control	TX Valves	TX Valves	TX Valves
Drain Connection No./Size in. [mm]	1/1 [25.4]	1/1 [25.4]	1/1 [25.4]
<b>Outdoor Fan—Type</b>			
	Propeller	Propeller	Propeller
No. Used/Diameter in. [mm]	6/24 [609.6]	6/24 [609.6]	6/24 [609.6]
Drive Type/No. Speeds	Direct/1	Direct/1	Direct/1
CFM [L/s]	6000 [2831]	6000 [2831]	6000 [2831]
No. Motors/HP	6 at 1/3 HP	6 at 1/3 HP	6 at 1/3 HP
Motor RPM	1075	1075	1075
<b>Indoor Fan—Type</b>			
	FC Centrifugal	FC Centrifugal	FC Centrifugal
No. Used/Diameter in. [mm]	2/18x9 [457x229]	2/18x9 [457x229]	2/18x9 [457x229]
Drive Type/No. Speeds	Belt (Adjustable)	Belt (Adjustable)	Belt (Adjustable)
No. Speeds	Single	Single	Single
No. Motors	1	1	1
Motor HP	5	7 1/2	7 1/2
Motor RPM	1755	1760	1760
Motor Frame Size	184	213	213
<b>Filter—Type</b>			
	Disposable	Disposable	Disposable
Furnished	Yes	Yes	Yes
(NO.) Size Recommended in. [mm x mm x mm]	(8)2x25x20 [51x635x508]	(8)2x25x20 [51x635x508]	(8)2x25x20 [51x635x508]
<b>Refrigerant Charge Oz. (Sys. 1/Sys. 2) [g]</b>			
	340/328 [9639/9299]	340/328 [9639/9299]	340/328 [9639/9299]
<b>Weights</b>			
Net Weight lbs. [kg]	1865 [846]	1894 [859]	1894 [859]
Ship Weight lbs. [kg]	1965 [891]	1994 [904]	1994 [904]

See Page 16 for Notes.

[ ] Designates Metric Conversions

**NOTES:**

- A. Cooling Performance is rated at 95° F ambient, 80° F entering dry bulb, 67° F entering wet bulb. Gross capacity does not include the effect of fan motor heat. AHRI capacity is net and includes the effect of fan motor heat. Units are suitable for operation to  $\pm 20\%$  of nominal cfm. Units are certified in accordance with the Unitary Air Source Heat Pump Equipment certification program, which is based on AHRI Standard 210/240 or 340/360.
- B. EER and Integrated Energy Efficiency Ratio (IEER) are rated in accordance with AHRI Standard 340/360.
- C. Outdoor Sound Rating shown is tested in accordance with AHRI Standard 270.



# COOLING PERFORMANCE DATA — RHPH2T180A

wbE		ENTERING INDOOR AIR @ 80°F [26.7°C] dbE ①											
		71°F [21.7°C]		67°F [19.4°C]		63°F [17.2°C]		61°F [16.1°C]		59°F [15.0°C]			
CFM [L/s]		7200 [3398]	6025 [2843]	4800 [2265]	7200 [3398]	6025 [2843]	4800 [2265]	7200 [3398]	6025 [2843]	4800 [2265]	7200 [3398]	6025 [2843]	4800 [2265]
DR ①		0.05	0.02	-0.07	0.05	0.02	-0.07	0.05	0.02	-0.07	0.05	0.02	-0.07
75 [23.9]	Total BTUH [kW]	211.4 [61.9]	207.0 [60.7]	197.4 [57.8]	203.0 [59.5]	198.8 [58.3]	189.6 [55.5]	198.4 [58.2]	194.3 [56.9]	185.3 [54.3]	197.6 [57.9]	193.5 [56.7]	184.5 [54.1]
	Sens BTUH [kW]	141.1 [41.3]	133.8 [39.2]	117.8 [34.5]	167.6 [49.1]	159.0 [46.6]	140.0 [41.0]	187.0 [54.8]	177.4 [52.0]	156.2 [45.8]	162.1 [47.5]	194.0 [56.9]	184.0 [53.9]
	Power	12.5	12.4	12.1	12.4	12.2	12.0	12.2	12.1	11.8	12.2	12.1	11.7
80 [26.7]	Total BTUH [kW]	206.7 [60.6]	202.5 [59.3]	193.1 [56.6]	198.4 [58.1]	194.3 [56.9]	185.2 [54.3]	193.8 [56.8]	189.8 [55.6]	181.0 [53.0]	193.1 [56.6]	189.0 [55.4]	180.3 [52.8]
	Sens BTUH [kW]	139.0 [40.7]	131.8 [38.6]	116.1 [34.0]	165.5 [48.5]	157.0 [46.0]	138.3 [40.5]	184.9 [54.2]	175.4 [51.4]	154.5 [45.3]	160.3 [47.0]	191.9 [56.2]	182.0 [53.3]
	Power	13.1	13.0	12.7	13.0	12.9	12.6	12.9	12.7	12.5	12.8	12.7	12.3
85 [29.4]	Total BTUH [kW]	201.6 [59.1]	197.5 [57.9]	188.3 [55.2]	193.2 [56.6]	189.2 [55.5]	180.4 [52.9]	188.7 [55.3]	184.8 [54.1]	176.2 [51.6]	188.0 [55.1]	184.0 [53.9]	175.5 [51.4]
	Sens BTUH [kW]	136.7 [40.0]	129.6 [38.0]	114.2 [33.5]	163.2 [47.8]	154.8 [45.4]	136.3 [40.0]	182.6 [53.5]	173.2 [50.8]	152.5 [44.7]	158.4 [46.4]	187.8 [55.0]	181.1 [53.9]
	Power	13.8	13.6	13.3	13.7	13.5	13.2	13.5	13.4	13.1	13.5	13.3	13.0
90 [32.2]	Total BTUH [kW]	196.1 [57.5]	192.0 [56.3]	183.1 [53.6]	187.7 [55.0]	183.8 [53.9]	175.2 [51.3]	183.1 [53.7]	179.3 [52.5]	171.0 [50.1]	182.3 [53.4]	178.5 [52.3]	170.3 [49.9]
	Sens BTUH [kW]	134.1 [39.3]	127.2 [37.3]	112.1 [32.8]	160.7 [47.1]	152.4 [44.7]	134.2 [39.3]	180.1 [52.8]	170.8 [50.1]	150.4 [44.1]	156.3 [45.8]	182.4 [53.4]	178.6 [52.3]
	Power	14.5	14.4	14.0	14.4	14.2	13.9	14.3	14.1	13.8	14.2	14.1	13.7
95 [35]	Total BTUH [kW]	190.0 [55.7]	186.1 [54.5]	177.4 [52.0]	181.6 [53.2]	177.9 [52.1]	169.6 [49.7]	177.1 [51.9]	173.4 [50.8]	165.3 [48.4]	176.2 [51.6]	172.6 [50.6]	164.6 [48.2]
	Sens BTUH [kW]	131.4 [38.5]	124.7 [36.5]	109.8 [32.2]	158.0 [46.3]	149.9 [43.9]	132.0 [38.7]	177.1 [51.9]	168.2 [49.3]	148.1 [43.4]	154.0 [45.1]	176.3 [51.7]	172.7 [50.6]
	Power	15.3	15.1	14.8	15.1	15.0	14.7	15.0	14.9	14.5	15	14.8	14.4
100 [37.8]	Total BTUH [kW]	183.5 [53.8]	179.7 [52.7]	171.3 [50.2]	175.1 [51.3]	171.5 [50.2]	163.5 [47.9]	170.5 [50.0]	167.0 [48.9]	159.2 [46.7]	169.7 [49.7]	166.2 [48.7]	158.5 [46.5]
	Sens BTUH [kW]	128.5 [37.7]	121.9 [35.7]	107.3 [31.5]	155.1 [45.4]	147.1 [43.1]	129.5 [38.0]	170.5 [50.0]	165.5 [48.5]	145.7 [42.7]	151.5 [44.4]	169.8 [49.8]	166.3 [48.7]
	Power	16.1	15.9	15.6	16	15.8	15.4	15.8	15.7	15.3	15.8	15.6	15.2
105 [40.6]	Total BTUH [kW]	176.5 [51.7]	172.8 [50.6]	164.8 [48.3]	168.1 [49.3]	164.6 [48.2]	157.0 [46.0]	163.5 [47.9]	160.2 [46.9]	152.7 [44.7]	162.7 [47.7]	159.3 [46.7]	152.0 [44.5]
	Sens BTUH [kW]	125.4 [36.7]	118.9 [34.8]	104.7 [30.7]	151.9 [44.5]	144.1 [42.2]	126.9 [37.2]	163.5 [47.9]	160.2 [46.9]	143.1 [41.9]	148.9 [43.6]	162.8 [47.7]	159.4 [46.7]
	Power	16.9	16.8	16.4	16.8	16.7	16.3	16.7	16.5	16.2	16.6	16.6	16.0
110 [43.3]	Total BTUH [kW]	169.0 [49.5]	165.5 [48.5]	157.8 [46.3]	160.6 [47.1]	157.3 [46.1]	150.0 [44.0]	156.1 [45.7]	152.8 [44.8]	145.7 [42.7]	155.2 [45.5]	152.1 [44.6]	145.1 [42.5]
	Sens BTUH [kW]	122.0 [35.8]	115.8 [33.9]	101.9 [29.9]	148.6 [43.5]	141.0 [41.3]	124.1 [36.4]	156.1 [45.7]	152.8 [44.8]	140.3 [41.1]	144.9 [42.5]	155.3 [45.5]	152.1 [44.6]
	Power	17.9	17.7	17.3	17.7	17.6	17.2	17.6	17.4	17.0	17.5	17.3	16.9
115 [46.1]	Total BTUH [kW]	161.1 [47.2]	157.8 [46.2]	150.4 [44.1]	152.7 [44.8]	149.5 [43.8]	142.6 [41.8]	148.1 [43.4]	145.1 [42.5]	138.3 [40.5]	147.3 [43.2]	144.3 [42.3]	137.7 [40.3]
	Sens BTUH [kW]	118.5 [34.7]	112.4 [32.9]	99.0 [29.0]	145.1 [42.5]	137.6 [40.3]	121.2 [35.5]	148.1 [43.4]	145.1 [42.5]	137.4 [40.3]	143.3 [42.3]	144.4 [42.3]	137.7 [40.3]
	Power	18.8	18.6	18.2	18.7	18.5	18.1	18.6	18.4	18.0	18.5	18.3	17.8
120 [48.9]	Total BTUH [kW]	152.7 [44.7]	149.5 [43.8]	142.6 [41.8]	144.3 [42.3]	141.3 [41.4]	134.8 [39.5]	139.7 [41.0]	136.9 [40.1]	130.5 [38.2]	138.9 [40.7]	136.0 [39.9]	129.8 [38.0]
	Sens BTUH [kW]	114.8 [33.6]	108.9 [31.9]	95.9 [28.1]	141.3 [41.4]	134.1 [39.3]	118.1 [34.6]	139.7 [41.0]	136.9 [40.1]	130.5 [38.2]	129.7 [38.0]	139.0 [40.7]	136.1 [39.9]
	Power	19.8	19.6	19.2	19.7	19.5	19.0	19.6	19.4	18.9	19.4	19.2	18.8
125 [51.7]	Total BTUH [kW]	143.8 [42.1]	140.9 [41.3]	134.3 [39.4]	135.4 [39.7]	132.6 [38.9]	126.5 [37.1]	130.9 [38.4]	128.2 [37.6]	122.2 [35.8]	130.0 [38.1]	127.3 [37.3]	121.5 [35.6]
	Sens BTUH [kW]	110.8 [32.5]	105.1 [30.8]	92.6 [27.1]	135.4 [39.7]	130.3 [38.2]	114.8 [33.6]	130.9 [38.4]	128.2 [37.6]	122.2 [35.8]	130.0 [38.1]	127.3 [37.3]	121.5 [35.6]
	Power	20.9	20.7	20.2	20.7	20.5	20.1	20.6	20.4	19.9	20.5	20.3	19.8

DR — Depression ratio  
dbE — Entering air dry bulb  
wbE — Entering air wet bulb

Total — Total capacity x 1000 BTUH  
Sens — Sensible capacity x 1000 BTUH  
Power — kW input

NOTES:  
① When the entering air dry bulb is other than 80°F [27°C], adjust the sensible capacity from the table by adding [1.10 x CFM x (1 - DR) x (dbE - 80)].

[ ] Designates Metric Conversions

## HEATING PERFORMANCE DATA—RHPH2T180A

IDB		60°F [15.5°C]			70°F [21.1°C]			80°F [26.7°C]			
		CFM [L/s]	7200 [3398]	6450 [3044]	4800 [2265]	7200 [3398]	6450 [3044]	4800 [2265]	7200 [3398]	6450 [3044]	4800 [2265]
OUTDOOR DRY BULB TEMPERATURE	0 [-17.8]	Total BTUH [kW] Power	60.0 [17.6] 8.5	59.5 [17.4] 8.6	58.4 [17.1] 8.9	55.9 [16.4] 9.7	55.4 [16.2] 9.8	54.4 [15.9] 10.2	51.7 [15.2] 10.8	51.3 [15.0] 11.0	50.3 [14.8] 11.4
	5 [-15]	Total BTUH [kW] Power	70.8 [20.8] 8.7	70.2 [20.6] 8.8	69.0 [20.2] 9.1	66.7 [19.5] 9.9	66.1 [19.4] 10.1	64.9 [19.0] 10.4	62.5 [18.3] 11.1	62.0 [18.2] 11.2	60.9 [17.8] 11.6
	10 [-12.2]	Total BTUH [kW] Power	81.6 [23.9] 8.9	81.0 [23.7] 9.1	79.5 [23.3] 9.4	77.5 [22.7] 10.1	76.8 [22.5] 10.3	75.4 [22.1] 10.6	73.3 [21.5] 11.3	72.7 [21.3] 11.5	71.4 [20.9] 11.8
	15 [-9.4]	Total BTUH [kW] Power	92.4 [27.1] 9.2	91.7 [26.9] 9.3	90.0 [26.4] 9.6	88.3 [25.9] 10.4	87.6 [25.7] 10.5	86.0 [25.2] 10.9	84.1 [24.7] 11.5	83.4 [24.4] 11.7	81.9 [24.0] 12.0
	20 [-6.7]	Total BTUH [kW] Power	103.2 [30.3] 9.4	102.4 [30.0] 9.5	100.5 [29.5] 9.8	99.1 [29.0] 10.6	98.3 [28.8] 10.7	96.5 [28.3] 11.1	94.9 [27.8] 11.7	94.2 [27.6] 11.9	92.4 [27.1] 12.3
	25 [-3.9]	Total BTUH [kW] Power	114.1 [33.4] 9.6	113.1 [33.1] 9.7	111.1 [32.5] 10.0	109.9 [32.2] 10.8	109.0 [31.9] 11.0	107.0 [31.4] 11.3	105.7 [31.0] 11.9	104.9 [30.7] 12.1	103.0 [30.2] 12.5
	30 [-1.1]	Total BTUH [kW] Power	124.9 [36.6] 9.8	123.8 [36.3] 10.0	121.6 [35.6] 10.3	120.7 [35.4] 11.0	119.7 [35.1] 11.2	117.5 [34.4] 11.5	116.5 [34.2] 12.2	115.6 [33.9] 12.3	113.5 [33.3] 12.7
	35 [1.7]	Total BTUH [kW] Power	135.7 [39.8] 10.0	134.6 [39.4] 10.2	132.1 [38.7] 10.5	131.5 [38.5] 11.2	130.4 [38.2] 11.4	128.0 [37.5] 11.8	127.4 [37.3] 12.4	126.3 [37.0] 12.6	124.0 [36.3] 13.0
	40 [4.4]	Total BTUH [kW] Power	146.5 [42.9] 10.2	145.3 [42.6] 10.4	142.6 [41.8] 10.7	142.3 [41.7] 11.5	141.1 [41.4] 11.6	138.6 [40.6] 12.0	138.2 [40.5] 12.6	137.0 [40.2] 12.8	134.5 [39.4] 13.2
	45 [7.2]	Total BTUH [kW] Power	157.3 [46.1] 10.5	156.0 [45.7] 10.6	153.1 [44.9] 11.0	153.1 [44.9] 11.7	151.9 [44.5] 11.9	149.1 [43.7] 12.2	149.0 [43.7] 12.8	147.7 [43.3] 13.0	145.0 [42.5] 13.4
50 [10]	Total BTUH [kW] Power	168.1 [49.3] 10.7	166.7 [48.9] 10.8	163.7 [48.0] 11.2	163.9 [48.0] 11.9	162.6 [47.6] 12.1	159.6 [46.8] 12.5	159.8 [46.8] 13.0	158.5 [46.4] 13.2	155.6 [45.6] 13.7	

IDB—Indoor air dry bulb

[ ] Designates Metric Conversions

# COOLING PERFORMANCE DATA — RHPH2T240A

wB/E		ENTERING INDOOR AIR @ 80°F [26.7°C] dbE ①														
		71°F [21.7°C]			67°F [19.4°C]			63°F [17.2°C]			61°F [16.1°C]			59°F [15.0°C]		
CFM [L/s]		9600 [453.1]	8200 [387.0]	6400 [302.0]	9600 [453.1]	8200 [387.0]	6400 [302.0]	9600 [453.1]	8200 [387.0]	6400 [302.0]	9600 [453.1]	8200 [387.0]	6400 [302.0]	9600 [453.1]	8200 [387.0]	6400 [302.0]
DR ①		0.09	0.06	-0.01	0.09	0.06	-0.01	0.09	0.06	-0.01	0.09	0.06	-0.01	0.09	0.06	-0.01
75 [23.9]	Total BTUH [kW]	292.2 [85.6]	283.4 [83.1]	272.1 [79.7]	280.9 [82.3]	272.4 [79.8]	261.5 [76.6]	275.3 [80.7]	267.0 [78.3]	256.4 [75.1]	275.5 [80.7]	267.3 [78.3]	256.6 [75.2]	278.4 [81.6]	270.0 [79.1]	259.2 [76.0]
	Sens BTUH [kW]	249.9 [73.2]	231.4 [67.8]	207.7 [60.9]	238.0 [69.7]	220.4 [64.6]	197.8 [58.0]	232.2 [68.0]	215.0 [63.0]	193.0 [56.6]	232.4 [68.1]	215.3 [63.1]	193.2 [56.6]	235.3 [69.0]	218.0 [63.9]	195.6 [57.3]
	Power	18.4	18.1	17.7	18.1	17.8	17.5	17.8	17.6	17.2	17.7	17.4	17.1	17.6	17.3	17.0
80 [26.7]	Total BTUH [kW]	286.5 [83.9]	277.8 [81.4]	266.7 [78.2]	275.1 [80.6]	266.8 [78.2]	256.2 [75.1]	269.5 [79.0]	261.4 [76.6]	251.0 [73.5]	269.8 [79.1]	261.6 [76.7]	251.2 [73.6]	272.6 [79.9]	264.4 [77.5]	253.8 [74.4]
	Sens BTUH [kW]	243.8 [71.4]	225.8 [66.2]	202.7 [59.4]	231.9 [68.0]	214.8 [62.9]	192.8 [56.5]	226.1 [66.3]	209.4 [61.4]	188.0 [55.1]	226.3 [66.3]	209.6 [61.4]	188.2 [55.1]	229.3 [67.2]	212.4 [62.2]	190.6 [55.9]
	Power	19.1	18.9	18.5	18.9	18.6	18.2	18.6	18.3	18.0	18.5	18.2	17.8	18.3	18.1	17.7
85 [29.4]	Total BTUH [kW]	280.0 [82.0]	271.5 [79.6]	260.7 [76.4]	268.6 [78.7]	260.5 [76.3]	250.1 [73.3]	263.0 [77.1]	255.1 [74.8]	244.9 [71.8]	263.3 [77.1]	255.3 [74.8]	245.2 [71.8]	266.1 [78.0]	258.1 [75.6]	247.8 [72.6]
	Sens BTUH [kW]	237.0 [69.5]	219.5 [64.3]	197.0 [57.7]	225.1 [66.0]	208.5 [61.1]	187.1 [54.8]	219.3 [64.3]	203.1 [59.5]	182.3 [53.4]	219.5 [64.3]	203.3 [59.6]	182.5 [53.5]	222.5 [65.2]	206.1 [60.4]	185.0 [54.2]
	Power	20.0	19.7	19.3	19.7	19.4	19.0	19.4	19.1	18.8	19.3	19.0	18.6	19.1	18.9	18.5
90 [32.2]	Total BTUH [kW]	272.8 [79.9]	264.5 [77.5]	254.0 [74.4]	261.4 [76.6]	253.5 [74.3]	243.4 [71.3]	255.8 [75.0]	248.1 [72.7]	238.2 [69.8]	256.1 [75.0]	248.4 [72.8]	238.5 [69.9]	258.9 [75.9]	251.1 [73.6]	241.1 [70.6]
	Sens BTUH [kW]	229.5 [67.2]	212.5 [62.3]	190.8 [55.9]	217.6 [63.8]	201.5 [59.1]	180.9 [53.0]	211.8 [62.1]	196.1 [57.5]	176.0 [51.6]	212.0 [62.1]	196.4 [57.5]	176.2 [51.6]	215.0 [63.0]	199.1 [58.3]	178.7 [52.4]
	Power	20.8	20.5	20.1	20.6	20.2	19.9	20.3	20.0	19.6	20.1	19.9	19.5	20.0	19.7	19.3
95 [35]	Total BTUH [kW]	264.9 [77.6]	256.9 [75.3]	246.6 [72.3]	253.5 [74.3]	245.9 [72.0]	236.0 [69.2]	247.9 [72.7]	240.5 [70.5]	230.9 [67.7]	248.2 [72.7]	240.7 [70.5]	231.1 [67.7]	251.0 [73.5]	243.4 [71.3]	233.7 [68.5]
	Sens BTUH [kW]	221.2 [64.8]	204.9 [60.0]	183.9 [53.9]	209.3 [61.3]	193.9 [56.8]	174.0 [51.0]	203.5 [59.6]	188.5 [55.2]	169.2 [49.6]	203.7 [59.7]	188.7 [55.3]	169.4 [49.6]	206.7 [60.6]	191.4 [56.1]	171.8 [50.3]
	Power	22.7	22.4	21.9	22.4	22.1	21.7	22.2	21.8	21.4	22.0	21.7	21.3	21.9	21.6	21.2
100 [37.8]	Total BTUH [kW]	256.2 [75.1]	248.5 [72.8]	238.6 [69.9]	244.9 [71.8]	237.5 [69.6]	228.0 [66.8]	239.3 [70.1]	232.1 [68.0]	222.9 [65.3]	239.6 [70.2]	232.3 [68.1]	223.1 [65.4]	242.4 [71.0]	235.1 [68.9]	225.7 [66.1]
	Sens BTUH [kW]	212.2 [62.2]	196.5 [57.6]	176.4 [51.7]	200.3 [58.7]	185.5 [54.4]	166.5 [48.8]	194.5 [57.0]	180.1 [52.8]	161.7 [47.4]	194.7 [57.1]	180.3 [52.8]	161.9 [47.4]	197.7 [57.9]	183.1 [53.6]	164.3 [48.2]
	Power	22.7	22.4	21.9	22.4	22.1	21.7	22.2	21.8	21.4	22.0	21.7	21.3	21.9	21.6	21.2
105 [40.6]	Total BTUH [kW]	246.9 [72.4]	239.5 [70.2]	229.9 [67.4]	235.6 [69.0]	228.5 [66.9]	219.3 [64.3]	230.0 [67.4]	223.1 [65.4]	214.2 [62.8]	230.2 [67.5]	223.3 [65.4]	214.4 [62.8]	233.0 [68.3]	226.0 [66.2]	217.0 [63.6]
	Sens BTUH [kW]	202.4 [59.3]	187.5 [54.9]	168.3 [49.3]	190.5 [55.8]	176.5 [51.7]	158.4 [46.4]	184.7 [54.1]	171.1 [50.1]	153.6 [45.0]	185.0 [54.2]	171.3 [50.2]	153.8 [45.1]	187.9 [55.1]	174.0 [51.0]	156.2 [45.8]
	Power	23.7	23.4	22.9	23.4	23.1	22.7	23.2	22.8	22.4	23.0	22.7	22.3	22.9	22.6	22.1
110 [43.3]	Total BTUH [kW]	236.9 [69.4]	229.8 [67.3]	220.6 [64.6]	225.5 [66.1]	218.7 [64.1]	210.0 [61.5]	220.0 [64.5]	213.4 [62.5]	204.8 [60.0]	220.2 [64.5]	213.6 [62.6]	205.1 [60.1]	223.0 [65.4]	216.3 [63.4]	207.7 [60.9]
	Sens BTUH [kW]	191.9 [56.2]	177.8 [52.1]	159.6 [46.8]	180.0 [52.8]	166.7 [48.9]	149.7 [43.9]	174.2 [51.1]	161.4 [47.3]	144.8 [42.4]	174.5 [51.1]	161.6 [47.4]	145.0 [42.5]	177.4 [52.0]	164.3 [48.1]	147.5 [43.2]
	Power	24.8	24.4	23.9	24.5	24.1	23.7	24.2	23.9	23.4	24.1	23.8	23.3	24.0	23.6	23.2
115 [46.1]	Total BTUH [kW]	226.2 [66.3]	219.4 [64.3]	210.6 [61.7]	214.8 [62.9]	208.3 [61.1]	200.0 [58.6]	209.3 [61.3]	203.0 [59.5]	194.9 [57.1]	209.5 [61.4]	203.2 [59.5]	195.1 [57.2]	212.3 [62.2]	205.9 [60.3]	197.7 [57.9]
	Sens BTUH [kW]	180.7 [53.0]	167.4 [49.0]	150.2 [44.0]	168.8 [49.5]	156.3 [45.8]	140.3 [41.1]	163.0 [47.8]	151.0 [44.2]	135.5 [39.7]	163.2 [47.8]	151.2 [44.3]	135.7 [39.8]	166.2 [48.7]	153.9 [45.1]	138.1 [40.5]
	Power	25.9	25.5	25.0	25.6	25.2	24.8	25.4	25.0	24.5	25.2	24.8	24.4	25.1	24.7	24.2
120 [48.9]	Total BTUH [kW]	214.7 [62.9]	208.3 [61.0]	200.0 [58.6]	203.4 [59.6]	197.2 [57.8]	189.4 [55.5]	197.8 [58.0]	191.9 [56.2]	184.2 [54.0]	198.1 [58.0]	192.1 [56.3]	184.4 [54.0]	200.9 [58.9]	194.8 [57.1]	187.0 [54.8]
	Sens BTUH [kW]	168.7 [49.4]	156.3 [45.8]	140.3 [41.1]	156.8 [46.0]	145.2 [42.6]	130.4 [38.2]	151.0 [44.3]	139.9 [41.0]	125.5 [36.8]	151.3 [44.3]	140.1 [41.1]	125.7 [36.8]	154.2 [45.2]	142.8 [41.9]	128.2 [37.6]
	Power	27.1	26.7	26.1	26.8	26.4	25.9	26.5	26.1	25.6	26.4	26.0	25.5	26.3	25.9	25.4
125 [51.7]	Total BTUH [kW]	202.6 [59.4]	196.5 [57.6]	188.7 [55.3]	191.2 [56.0]	185.5 [54.4]	178.1 [52.2]	185.7 [54.4]	180.1 [52.8]	172.9 [50.7]	185.9 [54.5]	180.3 [52.8]	173.1 [50.7]	188.7 [55.3]	183.0 [53.6]	175.7 [51.5]
	Sens BTUH [kW]	156.0 [45.7]	144.5 [42.3]	129.7 [38.0]	144.1 [42.2]	133.5 [39.1]	119.8 [35.1]	138.3 [40.5]	128.1 [37.5]	115.0 [33.7]	138.5 [40.6]	128.3 [37.6]	115.2 [33.7]	141.5 [41.5]	131.0 [38.4]	117.6 [34.5]
	Power	28.3	27.8	27.3	28.0	27.6	27.0	27.7	27.3	26.8	27.6	27.2	26.7	27.5	27.1	26.5

DR — Depression ratio  
dbE — Entering air dry bulb  
wB/E — Entering air wet bulb

Total — Total capacity x 1000 BTUH  
Sens — Sensible capacity x 1000 BTUH  
Power — kW input

NOTES:  
① When the entering air dry bulb is other than 80°F [27°C], adjust the sensible capacity from the table by adding [1.10 x CFM x (1 - DR) x (dbE - 80)].

[ ] Designates Metric Conversions

## HEATING PERFORMANCE DATA—RHPH2T240A

IDB		60°F [15.5°C]			70°F [21.1°C]			80°F [26.7°C]			
		CFM [L/s]	9600 [4531]	8200 [3870]	6400 [3020]	9600 [4531]	8200 [3870]	6400 [3020]	9600 [4531]	8200 [3870]	6400 [3020]
O U T D O O R  D R Y  B U L B  T E M P E R A T U R E  ° F [ ° C]	0 [-17.8]	Total BTUH [kW] Power	74.9 [21.9] 12.4	74.0 [21.7] 12.6	72.8 [21.3] 13.0	67.3 [19.7] 13.9	66.5 [19.5] 14.2	65.5 [19.2] 14.6	59.7 [17.5] 15.4	59.0 [17.3] 15.8	58.1 [17.0] 16.2
	5 [-15]	Total BTUH [kW] Power	92.5 [27.1] 12.8	91.4 [26.8] 13.0	90.0 [26.4] 13.4	84.9 [24.9] 14.3	83.9 [24.6] 14.6	82.6 [24.2] 15.0	77.3 [22.7] 15.8	76.4 [22.4] 16.2	75.2 [22.0] 16.6
	10 [-12.2]	Total BTUH [kW] Power	110.1 [32.3] 13.2	108.8 [31.9] 13.4	107.1 [31.4] 13.8	102.5 [30.1] 14.7	101.3 [29.7] 15.0	99.7 [29.2] 15.4	95.0 [27.8] 16.2	93.8 [27.5] 16.5	92.3 [27.1] 17.0
	15 [-9.4]	Total BTUH [kW] Power	127.8 [37.4] 13.5	126.2 [37.0] 13.8	124.2 [36.4] 14.2	120.2 [35.2] 15.1	118.7 [34.8] 15.4	116.9 [34.2] 15.8	112.6 [33.0] 16.6	111.2 [32.6] 16.9	109.5 [32.1] 17.4
	20 [-6.7]	Total BTUH [kW] Power	145.4 [42.6] 13.9	143.6 [42.1] 14.2	141.4 [41.4] 14.6	137.8 [40.4] 15.5	136.1 [39.9] 15.8	134.0 [39.3] 16.2	130.2 [38.2] 17.0	128.6 [37.7] 17.3	126.6 [37.1] 17.8
	25 [-3.9]	Total BTUH [kW] Power	163.0 [47.8] 14.3	161.0 [47.2] 14.6	158.5 [46.5] 15.0	155.4 [45.5] 15.9	153.5 [45.0] 16.2	151.1 [44.3] 16.6	147.8 [43.3] 17.4	146.0 [42.8] 17.7	143.7 [42.1] 18.2
	30 [-1.1]	Total BTUH [kW] Power	180.6 [52.9] 14.7	178.5 [52.3] 15.0	175.7 [51.5] 15.4	173.0 [50.7] 16.2	171.0 [50.1] 16.6	168.3 [49.3] 17.1	165.4 [48.5] 17.7	163.4 [47.9] 18.1	160.9 [47.1] 18.6
	35 [1.7]	Total BTUH [kW] Power	198.3 [58.1] 15.1	195.9 [57.4] 15.4	192.8 [56.5] 15.8	190.7 [55.9] 16.6	188.4 [55.2] 17.0	185.4 [54.3] 17.5	183.1 [53.6] 18.1	180.9 [53.0] 18.5	178.0 [52.2] 19.0
	40 [4.4]	Total BTUH [kW] Power	215.9 [63.3] 15.5	213.3 [62.5] 15.8	209.9 [61.5] 16.3	208.3 [61.0] 17.0	205.8 [60.3] 17.4	202.5 [59.4] 17.9	200.7 [58.8] 18.5	198.3 [58.1] 18.9	195.2 [57.2] 19.4
	45 [7.2]	Total BTUH [kW] Power	233.5 [68.4] 15.9	230.7 [67.6] 16.2	227.1 [66.5] 16.7	225.9 [66.2] 17.4	223.2 [65.4] 17.8	219.7 [64.4] 18.3	218.3 [64.0] 18.9	215.7 [63.2] 19.3	212.3 [62.2] 19.9
50 [10]	Total BTUH [kW] Power	251.1 [73.6] 16.3	248.1 [72.7] 16.6	244.2 [71.6] 17.1	243.5 [71.4] 17.8	240.6 [70.5] 18.2	236.8 [69.4] 18.7	235.9 [69.1] 19.3	233.1 [68.3] 19.7	229.4 [67.2] 20.3	

IDB—Indoor air dry bulb

[ ] Designates Metric Conversions

# AIRFLOW PERFORMANCE — 15 TON [52.8 kW]—SIDEFLOW

Air Flow CFM [L/s]	Model RHPH2180A Voltage 208/230, 460, 575 — 3 Phase																																										
	External Static Pressure—Inches of Water [kPa]																																										
	0.1 [1.02]	0.2 [1.05]	0.3 [1.07]	0.4 [1.10]	0.5 [1.12]	0.6 [1.15]	0.7 [1.17]	0.8 [1.20]	0.9 [1.22]	1.0 [1.25]	1.1 [1.27]	1.2 [1.30]	1.3 [1.32]	1.4 [1.35]	1.5 [1.37]	1.6 [1.40]	1.7 [1.42]	1.8 [1.45]	1.9 [1.47]	2.0 [1.50]																							
4800 [2265]	—	—	—	—	—	583	1393	608	1508	632	1621	656	1732	679	1841	701	1947	723	2052	744	2154	764	2254	785	2326	805	2430	825	2537	844	2647	863	2761	881	2878								
5000 [2359]	—	—	—	—	—	591	1476	616	1593	640	1707	663	1820	686	1930	708	2038	729	2145	750	2248	771	2350	791	2420	811	2528	830	2640	850	2755	868	2873	887	2995								
5200 [2454]	—	—	—	—	—	575	1442	600	1562	624	1681	648	1797	671	1911	693	2023	715	2133	736	2241	757	2346	777	2410	797	2520	817	2633	836	2749	855	2869	874	2992	892	3118						
5400 [2548]	—	—	—	—	—	583	1530	608	1652	632	1772	655	1890	678	2005	701	2119	722	2231	743	2340	764	2447	784	2512	804	2626	823	2744	842	2865	861	2989	879	3117	897	3248						
5600 [2643]	—	—	—	—	—	592	1621	616	1745	640	1866	663	1986	686	2103	708	2218	729	2331	750	2442	770	2551	791	2620	810	2739	830	2861	849	2987	867	3116	885	3248	903	3384						
5800 [2737]	—	—	—	—	—	576	1588	601	1715	625	1840	649	1964	672	2085	694	2204	716	2321	737	2436	757	2548	778	2614	798	2735	817	2858	836	2985	855	3116	873	3249	891	3386	909	3527				
6000 [2831]	—	—	—	—	—	585	1683	610	1813	634	1940	657	2065	680	2187	702	2308	724	2426	744	2543	765	2657	785	2731	805	2856	824	2984	843	3116	861	3251	879	3389	897	3531	914	3676				
6200 [2926]	—	—	—	—	—	570	1650	595	1783	619	1913	643	2042	666	2169	688	2293	710	2415	731	2535	752	2653	773	2728	792	2854	812	2984	831	3116	850	3253	868	3392	886	3535	903	3682	920	3832		
6400 [3020]	—	—	—	—	—	579	1750	604	1885	628	2017	652	2148	674	2276	697	2402	718	2526	739	2648	760	2767	780	2852	800	2983	819	3118	838	3255	856	3396	875	3541	892	3688	909	3839	926	3994		
6600 [3114]	—	—	—	—	—	589	1854	614	1991	637	2125	661	2257	683	2386	705	2514	727	2640	748	2763	768	2884	788	2984	808	3119	827	3258	845	3400	863	3546	881	3695	899	3847	916	4003	—	—		
6800 [3209]	—	—	—	—	—	574	1822	599	1961	623	2099	647	2235	670	2369	692	2500	714	2629	735	2756	756	2882	776	2984	796	3121	815	3262	834	3405	853	3552	871	3702	888	3856	905	4013	922	4173	—	—
7000 [3303]	—	—	—	—	—	584	1930	609	2072	633	2211	656	2349	679	2484	701	2617	723	2748	744	2877	764	3003	785	3124	804	3265	823	3410	842	3559	860	3710	878	3865	895	4024	912	4185	929	4350	—	—
7200 [3398]	570	1897	595	2042	619	2185	643	2327	666	2466	689	2602	711	2737	732	2870	753	3000	773	3127	793	3270	812	3416	831	3566	849	3719	868	3875	885	4035	902	4198	919	4364	—	—	—	—	—	—	

NOTE: F- Drive left of the bold line, G-Drive right of the bold line.

Drive Package	F						G					
Motor H.P. [W]	3.0 [2237.1]						5.0 [3728.5]					
Blower Sheave	BK105H						BK105H					
Motor Sheave	1VP-44						1VP-56					
Turns Open	1	2	3	4	5	6	1	2	3	4	5	6
RPM	<b>733</b>	701	669	640	605	572	927	903	873	<b>840</b>	808	775

- NOTES: 1. Factory sheave settings are shown in bold type.  
 2. Do not set motor sheave below minimum turns open shown.  
 3. Re-adjustment of sheave required to achieve rated airflow at AHRI minimum External Static Pressure.  
 4. Drive data shown is for horizontal airflow with dry coil. Add component resistance (below) to duct resistance to determine total External Static Pressure.

### COMPONENT AIR RESISTANCE — 15 TON [52.8 kW]

CFM [L/s]	Resistance — Inches of Water [kPa]													
	4800 [2265]	5000 [2360]	5200 [2454]	5400 [2549]	5600 [2643]	5800 [2737]	6000 [2832]	6200 [2926]	6400 [3020]	6600 [3115]	6800 [3209]	7000 [3304]	7200 [3398]	
Wet Coil	0.03 [0.01]	0.04 [0.01]	0.05 [0.01]	0.06 [0.01]	0.06 [0.01]	0.07 [0.02]	0.08 [0.02]	0.09 [0.02]	0.10 [0.02]	0.10 [0.02]	0.11 [0.03]	0.12 [0.03]	0.13 [0.03]	
Downflow	0.05 [0.01]	0.05 [0.01]	0.05 [0.01]	0.05 [0.01]	0.05 [0.01]	0.05 [0.01]	0.06 [0.01]	0.06 [0.01]	0.06 [0.01]	0.06 [0.01]	0.07 [0.02]	0.08 [0.02]	0.08 [0.02]	
Downflow Economizer R.A. Damper Open	0.09 [0.02]	0.10 [0.02]	0.10 [0.02]	0.11 [0.03]	0.12 [0.03]	0.13 [0.03]	0.13 [0.03]	0.14 [0.03]	0.15 [0.04]	0.16 [0.04]	0.16 [0.04]	0.17 [0.04]	0.18 [0.04]	
Horizontal Economizer R.A. Damper Open	0.00 [0.00]	0.01 [0.00]	0.01 [0.00]	0.02 [0.00]	0.02 [0.00]	0.03 [0.01]	0.03 [0.01]	0.04 [0.01]	0.04 [0.01]	0.05 [0.01]	0.05 [0.01]	0.06 [0.01]	0.06 [0.01]	
Concentric Grill RXRN-AD80 or RXRN-AD81 & Transition RXMC-CJ07	0.21 [0.05]	0.25 [0.06]	0.28 [0.07]	0.32 [0.08]	0.35 [0.09]	0.39 [0.10]	0.43 [0.11]	0.46 [0.11]	0.50 [0.12]	0.54 [0.13]	0.57 [0.14]	0.61 [0.15]	0.64 [0.16]	
Pressure Drop MERV 8	0.068 [0.02]	0.072 [0.02]	0.076 [0.02]	0.08 [0.02]	0.084 [0.02]	0.088 [0.02]	0.092 [0.02]	0.096 [0.02]	0.1 [0.02]	0.104 [0.02]	0.108 [0.03]	0.112 [0.03]	0.116 [0.03]	
Pressure Drop MERV 13	0.009 [0.00]	0.015 [0.00]	0.021 [0.00]	0.028 [0.01]	0.034 [0.01]	0.04 [0.01]	0.046 [0.01]	0.052 [0.01]	0.058 [0.01]	0.065 [0.02]	0.071 [0.02]	0.077 [0.02]	0.083 [0.02]	

### AIRFLOW CORRECTION FACTORS — 15 TON [52.8 kW]

ACTUAL—CFM [L/s]	4800 [2265]	5000 [2360]	5200 [2454]	5400 [2549]	5600 [2643]	5800 [2737]	6000 [2832]	6200 [2926]	6400 [3020]	6600 [3115]	6800 [3209]	7000 [3304]	7200 [3398]
TOTAL MBT	0.97	0.97	0.98	0.98	0.99	0.99	1.00	1.01	1.02	1.02	1.03	1.03	1.04
SENSIBLE MBT	0.87	0.90	0.92	0.94	0.97	0.99	1.02	1.04	1.06	1.09	1.11	1.14	1.16
POWER kW	0.98	0.98	0.99	0.99	0.99	1.00	1.00	1.00	1.01	1.01	1.01	1.02	1.02

NOTES: Multiply correction factor times gross performance data—resulting sensible capacity cannot exceed total capacity.

[ ] Designates Metric Conversions

# AIRFLOW PERFORMANCE — 20 TON [70.3 kW]—SIDEFLOW

Air Flow CFM [L/s]	Model RGEHU360A Voltage 208/230, 460, 575 — 3 phase 60 Hz																																							
	External Static Pressure—Inches of Water [kPa]																																							
	0.1 [0.02]	0.2 [0.05]	0.3 [0.07]	0.4 [0.10]	0.5 [0.12]	0.6 [0.15]	0.7 [0.17]	0.8 [0.20]	0.9 [0.22]	1.0 [0.25]	1.1 [0.27]	1.2 [0.30]	1.3 [0.32]	1.4 [0.35]	1.5 [0.37]	1.6 [0.40]	1.7 [0.42]	1.8 [0.45]	1.9 [0.47]	2.0 [0.50]																				
6400 [3020]	—	—	—	—	632	2007	654	2111	676	2218	698	2328	719	2439	741	2553	763	2670	785	2789	810	3065	830	3203	850	3342	869	3481	888	3621	906	3761	923	3902	937	4121				
6600 [3114]	—	—	—	—	642	2106	664	2217	686	2330	707	2446	729	2564	751	2685	773	2808	798	3060	819	3201	838	3342	857	3484	876	3626	894	3769	912	3912	930	4056	944	4271				
6800 [3209]	—	—	—	630	2100	652	2215	674	2332	696	2452	718	2574	739	2699	761	2826	783	2955	807	3202	827	3346	846	3490	865	3634	884	3780	901	3926	919	4072	933	4283	950	4432			
7000 [3303]	—	—	—	641	2213	663	2334	684	2458	706	2585	728	2713	750	2844	772	2977	796	3207	816	3352	835	3499	854	3646	873	3794	891	3942	909	4091	926	4240	940	4448	957	4603			
7200 [3398]	—	—	630	2211	651	2336	673	2464	695	2594	717	2727	739	2862	761	2999	783	3139	805	3282	825	3511	844	3661	863	3811	881	3961	898	4112	916	4264	932	4417	947	4624	964	4784		
7400 [3492]	—	—	641	2338	663	2470	684	2604	706	2741	728	2880	750	3021	772	3165	795	3375	815	3526	834	3678	853	3831	871	3984	889	4137	906	4292	923	4447	938	4650	954	4810	971	4976		
7600 [3586]	—	630	2339	652	2475	674	2613	696	2754	718	2897	740	3043	761	3190	783	3341	805	3545	824	3699	843	3854	862	4009	879	4165	897	4322	914	4479	930	4637	945	4841	962	5007	978	5179	
7800 [3681]	—	642	2480	664	2622	686	2767	707	2914	729	3064	751	3216	773	3370	795	3567	815	3723	834	3880	852	4038	870	4197	888	4356	905	4515	922	4675	936	4878	953	5043	969	5214	986	5392	
8000 [3775]	632	2485	654	2631	676	2780	698	2931	719	3085	741	3241	763	3399	785	3559	806	3750	825	3910	844	4070	862	4231	880	4392	897	4554	914	4717	930	4880	944	5084	961	5255	977	5432	993	5616
8200 [3869]	644	2640	666	2793	688	2948	710	3105	732	3265	754	3427	776	3592	797	3780	816	3942	835	4105	854	4268	871	4432	889	4596	906	4761	922	4927	936	5130	952	5300	969	5477	985	5660	1001	5850
8400 [3964]	657	2805	679	2964	701	3126	723	3290	745	3456	767	3625	789	3796	808	3978	827	4143	846	4309	864	4475	881	4642	898	4809	915	4977	931	5146	944	5352	961	5528	977	5710	993	5899	1008	6094
8600 [4058]	670	2980	692	3146	714	3314	736	3484	758	3657	780	3832	800	4017	819	4184	838	4352	856	4521	874	4690	891	4860	907	5030	924	5201	937	5408	953	5584	969	5765	985	5954	1001	6148	—	—
8800 [4153]	683	3166	705	3338	727	3512	749	3689	771	3868	793	4059	812	4229	831	4399	849	4570	867	4742	884	4914	901	5087	917	5260	933	5434	946	5645	962	5826	978	6013	993	6208	1009	6408	—	—
9000 [4247]	697	3361	719	3540	741	3721	763	3904	785	4089	805	4276	824	4449	842	4622	860	4796	877	4971	894	5146	911	5322	927	5498	939	5712	955	5892	971	6079	986	6272	1002	6472	—	—	—	—
9200 [4341]	711	3567	733	3752	755	3939	777	4129	798	4327	817	4502	835	4678	853	4854	871	5031	888	5209	905	5387	921	5565	933	5784	949	5963	964	6149	980	6342	995	6541	1010	6747	—	—	—	—
9400 [4436]	725	3783	747	3975	769	4168	792	4381	811	4558	829	4736	847	4915	865	5094	882	5274	899	5455	915	5636	931	5818	942	6040	958	6225	973	6418	989	6616	1004	6821	—	—	—	—	—	—
9600 [4530]	739	4010	762	4207	784	4407	805	4617	823	4798	842	4979	859	5161	877	5343	894	5526	910	5709	926	5894	937	6122	952	6307	968	6498	983	6696	998	6901	—	—	—	—	—	—	—	—

NOTE: F-Drive left of the bold line, G-Drive between two bold lines, and H-Drive to the right of the bold line.

# AIRFLOW CORRECTION FACTORS — 20 TON [70.3 kW]

Drive Package	F										G													
	1	2	3	4	5	6	1	2	3	4	5	6	1	2	3	4	5	6	1	2	3	4	5	6
Motor H.P. [W]	5 [3728.5]										7.5 [5592.7]													
Blower Sheave	BK130H										BK130H													
Motor Sheave	1VP-56										1VP-71													
Turns Open	1	2	3	4	5	6	1	2	3	4	5	6	1	2	3	4	5	6	1	2	3	4	5	6
RPM	<b>756</b>	734	709	683	658	631	928	902	874	<b>874</b>	820	793	1009	981	955	928	899	870	1009	981	955	928	899	870

NOTE: 1. Factory sheave settings are shown in bold type.  
2. Do not set motor sheave below minimum turns open shown.  
3. Re-adjustment of sheave required to achieve rated airflow at AHRI minimum External Static Pressure.  
4. Drive data shown is for horizontal airflow with dry coil. Add component resistance (below) to duct resistance to determine total External Static Pressure.

[ ] Designates Metric Conversions

## COMPONENT AIR RESISTANCE — 20 TON [70.3 kW]

CFM [L/s]	Resistance — Inches of Water [kPa]																
	6400 [3020]	6600 [3114]	6800 [3209]	7000 [3303]	7200 [3398]	7400 [3492]	7600 [3586]	7800 [3681]	8000 [3775]	8200 [3869]	8400 [3964]	8600 [4058]	8800 [4153]	9000 [4247]	9200 [4341]	9400 [4436]	9600 [4530]
Wet Coil	0.00 [.00]	0.00 [.00]	0.00 [.00]	0.01 [.00]	0.01 [.00]	0.02 [.00]	0.02 [.00]	0.03 [.01]	0.03 [.01]	0.04 [.01]	0.04 [.01]	0.05 [.01]	0.05 [.01]	0.06 [.01]	0.06 [.01]	0.07 [.02]	0.07 [.02]
Downflow	0.06 [.01]	0.06 [.01]	0.07 [.02]	0.08 [.02]	0.08 [.02]	0.09 [.02]	0.10 [.02]	0.11 [.03]	0.12 [.03]	0.13 [.03]	0.14 [.03]	0.15 [.04]	0.16 [.04]	0.18 [.04]	0.19 [.05]	0.20 [.05]	0.22 [.05]
Downflow Economizer RA Damper Open	0.15 [.04]	0.16 [.04]	0.16 [.04]	0.17 [.04]	0.18 [.04]	0.19 [.05]	0.20 [.05]	0.21 [.05]	0.22 [.05]	0.23 [.06]	0.24 [.06]	0.25 [.06]	0.26 [.06]	0.27 [.07]	0.28 [.07]	0.29 [.07]	0.30 [.07]
Horizontal Economizer RA Damper Open	0.04 [.01]	0.05 [.01]	0.05 [.01]	0.06 [.01]	0.06 [.01]	0.07 [.02]	0.07 [.02]	0.08 [.02]	0.09 [.02]	0.09 [.02]	0.10 [.02]	0.10 [.02]	0.11 [.03]	0.11 [.03]	0.12 [.03]	0.12 [.03]	0.13 [.03]
Concentric Grill FXRN-AD88 & Transition RXMC-CK08	0.26 [.06]	0.29 [.07]	0.32 [.08]	0.35 [.09]	0.38 [.09]	0.41 [.10]	0.44 [.11]	0.47 [.12]	0.50 [.12]	0.53 [.13]	0.56 [.14]	0.59 [.15]	0.62 [.15]	0.65 [.16]	0.69 [.17]	0.72 [.18]	0.75 [.19]
MERV 8	0.100	0.104	0.108	0.112	0.116	0.120	0.124	0.128	0.132	0.136	0.140	0.144	0.148	0.152	0.156	0.160	0.164
MERV 13	0.058	0.065	0.071	0.077	0.083	0.089	0.095	0.102	0.108	0.114	0.120	0.126	0.132	0.138	0.145	0.151	0.157

## AIRFLOW CORRECTION FACTORS — 20 TON [70.3 kW]

CFM [L/s]	6400 [3020]	6600 [3114]	6800 [3209]	7000 [3303]	7200 [3398]	7400 [3492]	7600 [3586]	7800 [3681]	8000 [3775]	8200 [3869]	8400 [3964]	8600 [4058]	8800 [4153]	9000 [4247]	9200 [4341]	9400 [4436]	9600 [4530]
Total MBH	0.97	0.97	0.98	0.98	0.99	0.99	1.00	1.00	1.01	1.01	1.02	1.02	1.03	1.03	1.03	1.04	1.04
Sensible MBH	0.88	0.90	0.92	0.94	0.96	0.97	0.99	1.01	1.03	1.05	1.07	1.09	1.10	1.12	1.14	1.16	1.18
Power kW	0.98	0.99	0.99	0.99	0.99	1.00	1.00	1.00	1.00	1.01	1.01	1.01	1.01	1.01	1.02	1.02	1.02

NOTES: Multiply correction factor times gross performance data—resulting sensible capacity cannot exceed total capacity.

[ ] Designates Metric Conversions



<b>ELECTRICAL DATA – RHPH2T SERIES WITHOUT POWERED EXHAUST</b>							
		<b>180ACF</b>	<b>180ACG</b>	<b>180ADF</b>	<b>180ADG</b>	<b>180AYF</b>	<b>180AYG</b>
<b>Unit Information</b>	Unit Operating Voltage Range	187-253	187-253	414-506	414-506	518-632	518-632
	Volts	208/230	208/230	460	460	575	575
	Phase	3	3	3	3	3	3
	Hz	60	60	60	60	60	60
	Minimum Circuit Ampacity	76/76	80/80	37	38	28	30
	Minimum Overcurrent Protection Device Size	90/90	90/90	40	45	30	35
	Maximum Overcurrent Protection Device Size	100/100	100/100	45	45	35	35
<b>Compressor Motor</b>	No.	2	2	2	2	2	2
	Volts	200/230	200/230	460	460	575	575
	Phase	3	3	3	3	3	3
	RPM	3450	3450	3450	3450	3450	3450
	HP, Compressor 1	7	7	7	7	7	7
	Amps (RLA), Comp. 1	25.9	25.9	12.2	12.2	9	9
	Amps (LRA), Comp. 1	164	164	100	100	78	78
	HP, Compressor 2	7	7	7	7	7	7
	Amps (RLA), Comp. 2	25.9	25.9	12.2	12.2	9	9
	Amps (LRA), Comp. 2	164	164	100	100	78	78
<b>Condenser Motor</b>	No.	4	4	4	4	4	4
	Volts	208/230	208/230	460	460	575	575
	Phase	1	1	1	1	1	1
	HP	1/3	1/3	1/3	1/3	1/3	1/3
	Amps (FLA, each)	2	2	1	1	1	1
	Amps (LRA, each)	3.9	3.9	1.8	1.8	1.5	1.5
<b>Evaporator Fan</b>	No.	1	1	1	1	1	1
	Volts	208/230	208/230	460	460	575	575
	Phase	3	3	3	3	3	3
	HP	3	5	3	5	3	5
	Amps (FLA, each)	9.2	13.6	4.6	6.3	3.5	5.1
	Amps (LRA, each)	74.5	95	38.1	47.5	30	38

### ELECTRICAL DATA – RHPH2T SERIES WITHOUT POWERED EXHAUST

		240ACF	240ACG	240ACH	240ADF	240ADG	240ADH	240AYF	240AYG	240AYH
<b>Unit Information</b>	Unit Operating Voltage Range	187-253	187-253	187-253	414-506	414-506	414-506	518-632	518-632	518-632
	Volts	208/230	208/230	208/230	460	460	460	575	575	575
	Phase	3	3	3	3	3	3	3	3	3
	Hz	60	60	60	60	60	60	60	60	60
	Minimum Circuit Ampacity	107/107	114	114	47	51	51	39	42	42
	Minimum Overcurrent Protection Device Size	125/125	125/125	125/125	60	60	60	45	45	45
	Maximum Overcurrent Protection Device Size	125/125	150/150	150/150	60	60	60	50	50	50
<b>Compressor Motor</b>	No.	2	2	2	2	2	2	2	2	2
	Volts	200/230	200/230	200/230	460	460	460	575	575	575
	Phase	3	3	3	3	3	3	3	3	3
	RPM	3450	3450	3450	3450	3450	3450	3450	3450	3450
	HP, Compressor 1	7	7	7	7	7	7	7	7	7
	Amps (RLA), Comp. 1	38.5	38.5	38.5	16	16	16	12.9	12.9	12.9
	Amps (LRA), Comp. 1	240	240	240	140	140	140	108	108	108
	HP, Compressor 2	7	7	7	7	7	7	7	7	7
	Amps (RLA), Comp. 2	32.5	32.5	32.5	14.7	14.7	14.7	11.3	11.3	11.3
	Amps (LRA), Comp. 2	240	240	240	130	130	130	93.7	93.7	93.7
<b>Condenser Motor</b>	No.	6	6	6	6	6	6	6	6	6
	Volts	208/230	208/230	208/230	460	460	460	575	575	575
	Phase	1	1	1	1	1	1	1	1	1
	HP	1/3	1/3	1/3	1/3	1/3	1/3	1/3	1/3	1/3
	Amps (FLA, each)	2	2	2	1	1	1	1	1	1
	Amps (LRA, each)	3.9	3.9	3.9	1.8	1.8	1.8	1.5	1.5	1.5
<b>Evaporator Fan</b>	No.	1	1	1	1	1	1	1	1	1
	Volts	208/230	208/230	208/230	460	460	460	575	575	575
	Phase	3	3	3	3	3	3	3	3	3
	HP	5	7 1/2	7 1/2	5	7 1/2	7 1/2	5	7 1/2	7 1/2
	Amps (FLA, each)	13.6	21	21	6.3	9.6	9.6	5.1	7.7	7.7
	Amps (LRA, each)	95	127	127	47.5	63.5	63.5	38	50.8	50.8

<b>ELECTRICAL DATA – RHPH2T SERIES WITH POWERED EXHAUST</b>							
		<b>180ACF</b>	<b>180ACG</b>	<b>180ADF</b>	<b>180ADG</b>	<b>180AYF</b>	<b>180AYG</b>
<b>Unit Information</b>	Unit Operating Voltage Range	187-253	187-253	414-506	414-506	518-632	518-632
	Volts	208/230	208/230	460	460	575	575
	Phase	3	3	3	3	3	3
	Hz	60	60	60	60	60	60
	Minimum Circuit Ampacity	86/86	90/90	41	43	31	33
	Minimum Overcurrent Protection Device Size	100/100	100/100	45	50	35	35
	Maximum Overcurrent Protection Device Size	110/110	110/110	50	50	35	40
<b>Compressor Motor</b>	No.	2	2	2	2	2	2
	Volts	200/230	200/230	460	460	575	575
	Phase	3	3	3	3	3	3
	RPM	3450	3450	3450	3450	3450	3450
	HP, Compressor 1	7	7	7	7	7	7
	Amps (RLA), Comp. 1	25.9	25.9	12.2	12.2	9	9
	Amps (LRA), Comp. 1	164	164	100	100	78	78
	HP, Compressor 2	7	7	7	7	7	7
	Amps (RLA), Comp. 2	25.9	25.9	12.2	12.2	9	9
	Amps (LRA), Comp. 2	164	164	100	100	78	78
<b>Condenser Motor</b>	No.	4	4	4	4	4	4
	Volts	208/230	208/230	460	460	575	575
	Phase	1	1	1	1	1	1
	HP	1/3	1/3	1/3	1/3	1/3	1/3
	Amps (FLA, each)	2	2	1	1	1	1
	Amps (LRA, each)	3.9	3.9	1.8	1.8	1.5	1.5
<b>Evaporator Fan</b>	No.	1	1	1	1	1	1
	Volts	208/230	208/230	460	460	575	575
	Phase	3	3	3	3	3	3
	HP	3	5	3	5	3	5
	Amps (FLA, each)	9.2	13.6	4.6	6.3	3.5	5.1
	Amps (LRA, each)	74.5	95	38.1	47.5	30	38

### ELECTRICAL DATA – RHPH2T SERIES WITH POWERED EXHAUST

		240ACF	240ACG	240ACH	240ADF	240ADG	240ADH	240AYF	240AYG	240AYH
<b>Unit Information</b>	Unit Operating Voltage Range	187-253	187-253	187-253	414-506	414-506	414-506	518-632	518-632	518-632
	Volts	208/230	208/230	208/230	460	460	460	575	575	575
	Phase	3	3	3	3	3	3	3	3	3
	Hz	60	60	60	60	60	60	60	60	60
	Minimum Circuit Ampacity	117/117	124/124	124/124	52	55	55	42	45	45
	Minimum Overcurrent Protection Device Size	150/150	150/150	150/150	60	60	60	45	50	50
	Maximum Overcurrent Protection Device Size	150/150	150/150	150/150	60	70	70	50	50	50
<b>Compressor Motor</b>	No.	2	2	2	2	2	2	2	2	2
	Volts	200/230	200/230	200/230	460	460	460	575	575	575
	Phase	3	3	3	3	3	3	3	3	3
	RPM	3450	3450	3450	3450	3450	3450	3450	3450	3450
	HP, Compressor 1	7	7	7	7	7	7	7	7	7
	Amps (RLA), Comp. 1	38.5	38.5	38.5	16	16	16	12.9	12.9	12.9
	Amps (LRA), Comp. 1	240	240	240	140	140	140	108	108	108
	HP, Compressor 2	7	7	7	7	7	7	7	7	7
	Amps (RLA), Comp. 2	32.5	32.5	32.5	14.7	14.7	14.7	11.3	11.3	11.3
	Amps (LRA), Comp. 2	240	240	240	130	130	130	93.7	93.7	93.7
<b>Condenser Motor</b>	No.	6	6	6	6	6	6	6	6	6
	Volts	208/230	208/230	208/230	460	460	460	575	575	575
	Phase	1	1	1	1	1	1	1	1	1
	HP	1/3	1/3	1/3	1/3	1/3	1/3	1/3	1/3	1/3
	Amps (FLA, each)	2	2	2	1	1	1	1	1	1
	Amps (LRA, each)	3.9	3.9	3.9	1.8	1.8	1.8	1.5	1.5	1.5
<b>Evaporator Fan</b>	No.	1	1	1	1	1	1	1	1	1
	Volts	208/230	208/230	208/230	460	460	460	575	575	575
	Phase	3	3	3	3	3	3	3	3	3
	HP	5	7 1/2	7 1/2	5	7 1/2	7 1/2	5	7 1/2	7 1/2
	Amps (FLA, each)	13.6	21	21	6.3	9.6	9.6	5.1	7.7	7.7
	Amps (LRA, each)	95	127	127	47.5	63.5	63.5	38	50.8	50.8

280/240 VOLT, THREE PHASE, 60 HZ, AUXILIARY ELECTRIC HEATER KITS CHARACTERISTICS AND APPLICATION WITHOUT POWERED EXHAUST												
Single Power Supply for Both Unit and Heater Kit						Separate Power Supply for Both Unit and Heater Kit						
Unit Model Number	RXJJ-Heater Kit Nominal kW	No. of Sequence Steps	Rated Heater kW @ 280/240V	Heater MBH @ 208/240V	Heater Amps @ 208/240V	Unit Min. Ampacity @ 208/240V	Heat Pump		Heater Kit		Heat Pump	
							Overcurrent Protective Device Size Min./Max @ 208V	Overcurrent Protective Device Size Min./Max. @ 240V	Min. Ckt. Ampacity 208/240V	Max. Fuse Size 208/240V	Min. Ckt. Ampacity 208/240V	Overcurrent Protective Device Size Min./Max. @ 240V
RHPH2T180ACF	No Heat	—	—	—	—	76/76	90/100	90/100	—	—	90/100	90/100
	CE20C	1	14.4/19.2	49.13/65.51	40.0/46.2	126/134	150/150	150/150	50/58	50/60	90/100	90/100
	CE40C	2	28.8/38.3	98.27/130.69	79.9/92.2	176/191	200/200	225/225	100/116	100/125	90/100	90/100
	CE60C	2	43.2/57.5	147.40/196.20	119.9/138.3	226/249	250/250	300/300	150/173	150/175	90/100	90/100
	CE75C	2	54.0/71.9	184.26/245.33	149.8/172.8	263/292	300/300	350/350	188/216	200/225	90/100	90/100
RHPH2T180ACG	No Heat	—	—	—	—	80/80	90/100	90/100	—	—	90/100	90/100
	CE20C	1	14.4/19.2	49.13/65.51	40.0/46.2	130/138	150/150	150/150	50/58	50/60	90/100	90/100
	CE40C	2	28.8/38.3	98.27/130.69	79.9/92.2	180/196	200/200	225/225	100/116	100/125	90/100	90/100
	CE60C	2	43.2/57.5	147.40/196.20	119.9/138.3	230/253	250/250	300/300	150/173	150/175	90/100	90/100
	CE75C	2	54.0/71.9	184.26/245.33	149.8/172.8	268/296	300/300	350/350	188/216	200/225	90/100	90/100
RHPH2T240ACF	No Heat	—	—	—	—	107/107	125/125	125/125	—	—	125/125	125/125
	CE20C	1	14.4/19.2	49.13/65.51	40.0/46.2	157/164	175/175	200/200	50/58	50/60	125/125	125/125
	CE40C	2	28.8/38.3	98.27/130.69	79.9/92.2	207/222	225/225	250/250	100/116	100/125	125/125	125/125
	CE60C	2	43.2/57.5	147.40/196.20	119.9/138.3	257/280	300/300	300/300	150/173	150/175	125/125	125/125
	CE75C	2	54.0/71.9	184.26/245.33	149.8/172.8	294/323	350/350	350/350	188/216	200/225	125/125	125/125
RHPH2T240ACG	No Heat	—	—	—	—	114/114	125/150	125/150	—	—	125/150	125/150
	CE20C	1	14.4/19.2	49.13/65.51	40.0/46.2	164/172	200/200	200/200	50/58	50/60	125/150	125/150
	CE40C	2	28.8/38.3	98.27/130.69	79.9/92.2	214/229	250/250	250/250	100/116	100/125	125/150	125/150
	CE60C	2	43.2/57.5	147.40/196.20	119.9/138.3	264/287	300/300	350/350	150/173	150/175	125/150	125/150
	CE75C	2	54.0/71.9	184.26/245.33	149.8/172.8	301/330	350/350	350/350	188/216	200/225	125/150	125/150
RHPH2T240ACH	No Heat	—	—	—	—	114/114	125/150	125/150	—	—	125/150	125/150
	CE20C	1	14.4/19.2	49.13/65.51	40.0/46.2	164/172	200/200	200/200	50/58	50/60	125/150	125/150
	CE40C	2	28.8/38.3	98.27/130.69	79.9/92.2	214/229	250/250	250/250	100/116	100/125	125/150	125/150
	CE60C	2	43.2/57.5	147.40/196.20	119.9/138.3	264/287	300/300	350/350	150/173	150/175	125/150	125/150
	CE75C	2	54.0/71.9	184.26/245.33	149.8/172.8	301/330	350/350	350/350	188/216	200/225	125/150	125/150

480 VOLT, THREE PHASE, 60 HZ, AUXILIARY ELECTRIC HEATER KITS CHARACTERISTICS AND APPLICATION WITHOUT POWERED EXHAUST												
Single Power Supply for Both Unit and Heater Kit						Separate Power Supply for Both Unit and Heater Kit						
Unit Model Number	RXJJ- Heater Kit Nominal kW	No. of Sequence Steps	Rated Heater kW @ 480V	Heater MBH @ 480V	Heater Amps @ 480V	Unit Min. Ampacity @ 480V	Heat Pump		Heater Kit		Heat Pump	
							Overcurrent Protective Device Size	Min./Max. @ 480V	Min. Ckt. Ampacity 480V	Max. Fuse Size 480V	Min. Ckt. Ampacity 480V	Overcurrent Protective Device Size
RHPH2T180ADF	No Heat	—	—	—	—	37	40/45	—	—	—	—	—
	CE20D	1	19.2	65.50	23.1	65	80/80	—	29	30	37	40/45
	CE40D	2	38.4	131.00	46.2	94	100/100	—	58	60	37	40/45
	CE60D	2	57.6	196.50	69.3	123	150/150	—	87	90	37	40/45
RHPH2T180ADG	CE75D	2	72	245.63	86.6	145	150/150	—	109	110	37	40/45
	No Heat	—	—	—	—	38	45/45	—	—	—	38	45/45
	CE20D	1	19.2	65.50	23.1	67	80/80	—	29	30	38	45/45
	CE40D	2	38.4	131.00	46.2	96	110/110	—	58	60	38	45/45
RHPH2T240ADF	CE60D	2	57.6	196.50	69.3	125	150/150	—	87	90	38	45/45
	CE75D	2	72	245.63	86.6	146	175/175	—	109	110	38	45/45
	No Heat	—	—	—	—	47	60/60	—	—	—	47	60/60
	CE20D	1	19.2	65.50	23.1	76	90/90	—	29	30	47	60/60
RHPH2T240ADG	CE40D	2	38.4	131.00	46.2	105	125/125	—	58	60	47	60/60
	CE60D	2	57.6	196.50	69.3	134	150/150	—	87	90	47	60/60
	CE75D	2	72	245.63	86.6	156	175/175	—	109	110	47	60/60
	No Heat	—	—	—	—	51	60/60	—	—	—	51	60/60
RHPH2T240ADH	CE20D	1	19.2	65.50	23.1	80	90/90	—	29	30	51	60/60
	CE40D	2	38.4	131.00	46.2	109	125/125	—	58	60	51	60/60
	CE60D	2	57.6	196.50	69.3	137	150/150	—	87	90	51	60/60
	CE75D	2	72	245.63	86.6	159	175/175	—	109	110	51	60/60
RHPH2T240ADH	No Heat	—	—	—	—	51	60/60	—	—	—	51	60/60
	CE20D	1	19.2	65.50	23.1	80	90/90	—	29	30	51	60/60
	CE40D	2	38.4	131.00	46.2	109	125/125	—	58	60	51	60/60
	CE60D	2	57.6	196.50	69.3	137	150/150	—	87	90	51	60/60
RHPH2T240ADH	CE75D	2	72	245.63	86.6	159	175/175	—	109	110	51	60/60

600 VOLT, THREE PHASE, 60 HZ, AUXILIARY ELECTRIC HEATER KITS CHARACTERISTICS AND WITHOUT POWERED EXHAUST														
Single Power Supply for Both Unit and Heater Kit							Separate Power Supply for Both Unit and Heater Kit							
Unit Model Number	RXJJ-Heater Kit Nominal kW	No. of Sequence Steps	Rated Heater kW @ 600V	Heater MBH @ 600V	Heater Amps @ 600V	Unit Min. Ampacity @ 600V	Heat Pump		Heater Kit			Heat Pump		
							Overcurrent Protective Device Size Min./Max. @ 600V	Overcurrent Protective Device Size Min./Max. @ 600V	Min. Ckt. Ampacity 600V	Max. Fuse Size 600V	Min. Ckt. Ampacity 600V	Overcurrent Protective Device Size Min./Max. @ 600V		
H2T180AYF	No Heat	—	—	—	—	28	30/35	—	—	—	—	28	30/35	—
	CE20Y	1	19.2	65.50	18.5	51	60/60	—	24	25	28	30/35	—	
	CE40Y	2	38.4	131.00	37	74	80/80	—	47	50	28	30/35	—	
	CE60Y	2	57.6	196.50	55.4	97	110/110	—	70	70	28	30/35	—	
RHPH2T180AYG	CE75Y	2	72	245.63	69.3	115	125/125	—	87	90	28	30/35	—	
	No Heat	—	—	—	—	30	35/35	—	—	—	30	35/35	—	
	CE20Y	1	19.2	65.50	18.5	53	60/60	—	24	25	30	35/35	—	
	CE40Y	2	38.4	131.00	37	76	90/90	—	47	50	30	35/35	—	
RHPH2T240AYF	CE60Y	2	57.6	196.50	55.4	99	110/110	—	70	70	30	35/35	—	
	CE75Y	2	72	245.63	69.3	116	125/125	—	87	90	30	35/35	—	
	No Heat	—	—	—	—	39	45/50	—	—	—	39	45/50	—	
	CE20Y	1	19.2	65.50	18.5	62	70/70	—	24	25	39	45/50	—	
RHPH2T240AYG	CE40Y	2	38.4	131.00	37	85	100/100	—	47	50	39	45/50	—	
	CE60Y	2	57.6	196.50	55.4	108	125/125	—	70	70	39	45/50	—	
	CE75Y	2	72	245.63	69.3	126	150/150	—	87	90	39	45/50	—	
	No Heat	—	—	—	—	42	45/50	—	—	—	42	45/50	—	
RHPH2T240AYH	CE20Y	1	19.2	65.50	18.5	65	80/80	—	24	25	42	45/50	—	
	CE40Y	2	38.4	131.00	37	88	100/100	—	47	50	42	45/50	—	
	CE60Y	2	57.6	196.50	55.4	111	125/125	—	70	70	42	45/50	—	
	CE75Y	2	72	245.63	69.3	128	150/150	—	87	90	42	45/50	—	
RHPH2T240AYH	No Heat	—	—	—	—	42	45/50	—	—	—	42	45/50	—	
	CE20Y	1	19.2	65.50	18.5	65	80/80	—	24	25	42	45/50	—	
	CE40Y	2	38.4	131.00	37	88	100/100	—	47	50	42	45/50	—	
	CE60Y	2	57.6	196.50	55.4	111	125/125	—	70	70	42	45/50	—	
RHPH2T240AYH	CE75Y	2	72	245.63	69.3	128	150/150	—	87	90	42	45/50	—	

280/240 VOLT, THREE PHASE, 60 HZ, AUXILIARY ELECTRIC HEATER KITS CHARACTERISTICS AND APPLICATION WITH POWERED EXHAUST

Unit Model Number	Single Power Supply for Both Unit and Heater Kit										Separate Power Supply for Both Unit and Heater Kit									
	Heater Kit					Heat Pump					Heater Kit					Heat Pump				
	RXJJ- Heater Kit Nominal kW	No. of Sequence Steps	Rated Heater kW @ 280/240V	Heater MBH @ 208/240V	Heater Amps @ 208/240V	Unit Min. Ckt. Ampacity @ 208/240V	Min./Max @ 208V	Overcurrent Protective Device Size @ 240V	Min. Ckt. Ampacity 208/240V	Max. Fuse Size 208/240V	Min. Ckt. Ampacity 208/240V	Min./Max. @ 208V	Overcurrent Protective Device Size @ 240V	Min. Ckt. Ampacity 208/240V	Max. Fuse Size 208/240V	Min. Ckt. Ampacity 208/240V	Min./Max. @ 208V	Overcurrent Protective Device Size @ 240V		
RHPH2T180ACF	No Heat	—	—	—	—	86/86	100/110	100/110	—	—	—	100/110	100/110	—	—	—	100/110	100/110		
	CE20C	1	14.4/19.2	49.13/65.50	40.0/46.2	136/144	150/150	150/150	50/58	50/60	50/58	150/150	100/110	86/86	50/60	50/58	100/110	100/110		
	CE40C	2	28.8/38.4	98.25/131.00	79.9/92.4	186/201	200/200	225/225	100/116	100/125	100/116	200/200	100/110	86/86	100/125	100/116	100/110	100/110		
	CE60C	2	43.2/57.6	147.38/196.50	119.9/138.6	236/259	250/250	300/300	150/174	150/175	150/174	300/300	100/110	86/86	150/175	150/174	100/110	100/110		
RHPH2T180ACG	No Heat	—	—	—	—	90/90	100/110	100/110	—	—	—	100/110	100/110	—	—	—	100/110	100/110		
	CE20C	1	14.4/19.2	49.13/65.50	40.0/46.2	140/148	150/150	150/150	50/58	50/60	50/58	150/150	100/110	86/86	50/60	50/58	100/110	100/110		
	CE40C	2	28.8/38.4	98.25/131.00	79.9/92.4	190/206	200/200	225/225	100/116	100/125	100/116	200/200	100/110	86/86	100/125	100/116	100/110	100/110		
	CE60C	2	43.2/57.6	147.38/196.50	119.9/138.6	240/264	250/250	300/300	150/174	150/175	150/174	300/300	100/110	86/86	150/175	150/174	100/110	100/110		
RHPH2T240ACF	No Heat	—	—	—	—	117/117	150/150	150/150	—	—	—	150/150	150/150	—	—	—	150/150	150/150		
	CE20C	1	14.4/19.2	49.13/65.50	40.0/46.2	167/174	175/175	175/200	50/58	50/60	50/58	175/200	100/110	117/117	50/60	50/58	100/110	100/110		
	CE40C	2	28.8/38.4	98.25/131.00	79.9/92.4	217/232	225/225	250/250	100/116	100/125	100/116	250/250	100/110	117/117	100/125	100/116	100/110	100/110		
	CE60C	2	43.2/57.6	147.38/196.50	119.9/138.6	267/290	300/300	300/300	150/174	150/175	150/174	300/300	100/110	117/117	150/175	150/174	100/110	100/110		
RHPH2T240ACG	No Heat	—	—	—	—	124/124	150/150	150/150	—	—	—	150/150	150/150	—	—	—	150/150	150/150		
	CE20C	1	14.4/19.2	49.13/65.50	40.0/46.2	174/182	175/200	200/200	50/58	50/60	50/58	200/200	100/110	124/124	50/60	50/58	100/110	100/110		
	CE40C	2	28.8/38.4	98.25/131.00	79.9/92.4	224/240	225/225	250/250	100/116	100/125	100/116	250/250	100/110	124/124	100/125	100/116	100/110	100/110		
	CE60C	2	43.2/57.6	147.38/196.50	119.9/138.6	274/297	300/300	300/300	150/174	150/175	150/174	300/300	100/110	124/124	150/175	150/174	100/110	100/110		
RHPH2T240ACH	No Heat	—	—	—	—	124/124	150/150	150/150	—	—	—	150/150	150/150	—	—	—	150/150	150/150		
	CE20C	1	14.4/19.2	49.13/65.50	40.0/46.2	174/182	175/200	200/200	50/58	50/60	50/58	200/200	100/110	124/124	50/60	50/58	100/110	100/110		
	CE40C	2	28.8/38.4	98.25/131.00	79.9/92.4	224/240	225/225	250/250	100/116	100/125	100/116	250/250	100/110	124/124	100/125	100/116	100/110	100/110		
	CE60C	2	43.2/57.6	147.38/196.50	119.9/138.6	274/297	300/300	300/300	150/174	150/175	150/174	300/300	100/110	124/124	150/175	150/174	100/110	100/110		
RHPH2T240ACH	No Heat	—	—	—	—	311/341	350/350	350/350	—	—	—	350/350	350/350	—	—	—	350/350	350/350		
	CE20C	1	14.4/19.2	49.13/65.50	40.0/46.2	311/341	350/350	350/350	188/217	200/225	188/217	350/350	100/110	124/124	200/225	188/217	100/110	100/110		
	CE40C	2	28.8/38.4	98.25/131.00	79.9/92.4	311/341	350/350	350/350	100/116	200/225	100/116	350/350	100/110	124/124	200/225	100/116	100/110	100/110		
	CE60C	2	43.2/57.6	147.38/196.50	119.9/138.6	311/341	350/350	350/350	150/174	200/225	150/174	350/350	100/110	124/124	200/225	150/174	100/110	100/110		



480 VOLT, THREE PHASE, 60 HZ, AUXILIARY ELECTRIC HEATER KITS CHARACTERISTICS AND APPLICATION WITH POWERED EXHAUST													
Single Power Supply for Both Unit and Heater Kit						Separate Power Supply for Both Unit and Heater Kit							
Unit Model Number	RXJJ-Heater Kit Nominal kW	No. of Sequence Steps	Rated Heater kW @ 480V	Heater MBH @ 480V	Heater Amps @ 480V	Unit Min. Ampacity @ 480V	Heat Pump		Heater Kit			Heat Pump	
							Overcurrent Protective Device Size Min./Max. @ 480V	Min./Max. @ 480V	Min. Ckt. Ampacity 480V	Max. Fuse Size 480V	Min. Ckt. Ampacity 480V	Overcurrent Protective Device Size Min./Max. @ 480V	
RHPH2T180ADF	No Heat	—	—	—	—	41	45/50	—	—	—	41	45/50	—
	CE20D	1	19.2	65.5	23.1	70	70/70	—	29	30	41	45/50	—
	CE40D	2	38.4	131	46.2	99	100/100	—	58	60	41	45/50	—
	CE60D	2	57.6	196.5	69.3	128	150/150	—	87	90	41	45/50	—
RHPH2T180ADG	CE75D	2	72	245.63	86.6	149	150/150	—	109	110	41	45/50	—
	No Heat	—	—	—	—	43	50/50	—	—	—	43	50/50	—
	CE20D	1	19.2	65.5	23.1	72	80/80	—	29	30	43	50/50	—
	CE40D	2	38.4	131	46.2	100	100/100	—	58	60	43	50/50	—
RHPH2T240ADF	CE60D	2	57.6	196.5	69.3	129	150/150	—	87	90	43	50/50	—
	CE75D	2	72	245.63	86.6	151	175/175	—	109	110	43	50/50	—
	No Heat	—	—	—	—	52	60/60	—	—	—	52	60/60	—
	CE20D	1	19.2	65.5	23.1	81	90/90	—	29	30	52	60/60	—
RHPH2T240ADG	CE40D	2	38.4	131	46.2	110	110/110	—	58	60	52	60/60	—
	CE60D	2	57.6	196.5	69.3	139	150/150	—	87	90	52	60/60	—
	CE75D	2	72	245.63	86.6	160	175/175	—	109	110	52	60/60	—
	No Heat	—	—	—	—	55	60/70	—	—	—	55	60/70	—
RHPH2T240ADH	CE20D	1	19.2	65.5	23.1	84	90/90	—	29	30	55	60/70	—
	CE40D	2	38.4	131	46.2	113	125/125	—	58	60	55	60/70	—
	CE60D	2	57.6	196.5	69.3	142	150/150	—	87	90	55	60/70	—
	CE75D	2	72	245.63	86.6	163	175/175	—	109	110	55	60/70	—
RHPH2T240ADH	No Heat	—	—	—	—	55	60/70	—	—	—	55	60/70	—
	CE20D	1	19.2	65.5	23.1	84	90/90	—	29	30	55	60/70	—
	CE40D	2	38.4	131	46.2	113	125/125	—	58	60	55	60/70	—
	CE60D	2	57.6	196.5	69.3	142	150/150	—	87	90	55	60/70	—
RHPH2T240ADH	CE75D	2	72	245.63	86.6	163	175/175	—	109	110	55	60/70	—

**600 VOLT, THREE PHASE, 60 HZ, AUXILIARY ELECTRIC HEATER KITS CHARACTERISTICS AND APPLICATION WITH POWERED EXHAUST**

		Single Power Supply for Both Unit and Heater Kit						Separate Power Supply for Both Unit and Heater Kit						
Unit Model Number	RXJJ- Heater Kit Nominal kW	No. of Sequence Steps	Rated Heater kW @ 600V	Heater MBH @ 600V	Heater Amps @ 600V	Unit Min. Ckt. Ampacity @ 600V	Heat Pump		Heater Kit		Heat Pump			
							Overcurrent Protective Device Size Min./Max. @ 600V	Min. Ckt. Ampacity 600V	Max. Fuse Size 600V	Min. Ckt. Ampacity 600V	Overcurrent Protective Device Size Min./Max. @ 600V	Min./Max. @ 600V	Overcurrent Protective Device Size Min./Max. @ 600V	
														Min./Max. @ 600V
RHPH2T180AYF	No Heat	—	—	—	—	31	35/35	—	—	—	—	31	35/35	—
	CE20Y	1	19.2	65.5	18.5	54	60/60	24	25	24	25	31	35/35	—
	CE40Y	2	38.4	131	37	77	80/80	47	50	47	50	31	35/35	—
	CE60Y	2	57.6	196.5	55.4	100	100/100	70	70	70	70	31	35/35	—
	CE75Y	2	72	245.63	69.3	118	125/125	87	90	87	90	31	35/35	—
RHPH2T180AYG	No Heat	—	—	—	—	33	35/40	—	—	—	—	33	35/40	—
	CE20Y	1	19.2	65.5	18.5	56	60/60	24	25	24	25	33	35/40	—
	CE40Y	2	38.4	131	37	79	80/80	47	50	47	50	33	35/40	—
	CE60Y	2	57.6	196.5	55.4	102	110/110	70	70	70	70	33	35/40	—
	CE75Y	2	72	245.63	69.3	119	125/125	87	90	87	90	33	35/40	—
RHPH2T240AYF	No Heat	—	—	—	—	42	45/50	—	—	—	—	42	45/50	—
	CE20Y	1	19.2	65.5	18.5	65	70/70	24	25	24	25	42	45/50	—
	CE40Y	2	38.4	131	37	88	90/90	47	50	47	50	42	45/50	—
	CE60Y	2	57.6	196.5	55.4	111	125/125	70	70	70	70	42	45/50	—
	CE75Y	2	72	245.63	69.3	129	150/150	87	90	87	90	42	45/50	—
RHPH2T240AYG	No Heat	—	—	—	—	45	50/50	—	—	—	—	45	50/50	—
	CE20Y	1	19.2	65.5	18.5	68	70/70	24	25	24	25	45	50/50	—
	CE40Y	2	38.4	131	37	91	100/100	47	50	47	50	45	50/50	—
	CE60Y	2	57.6	196.5	55.4	114	125/125	70	70	70	70	45	50/50	—
	CE75Y	2	72	245.63	69.3	131	150/150	87	90	87	90	45	50/50	—
RHPH2T240AYH	No Heat	—	—	—	—	45	50/50	—	—	—	—	45	50/50	—
	CE20Y	1	19.2	65.5	18.5	68	70/70	24	25	24	25	45	50/50	—
	CE40Y	2	38.4	131	37	91	100/100	47	50	47	50	45	50/50	—
	CE60Y	2	57.6	196.5	55.4	114	125/125	70	70	70	70	45	50/50	—
	CE75Y	2	72	245.63	69.3	131	150/150	87	90	87	90	45	50/50	—

# SELF-CONTAINED HEAT PUMP

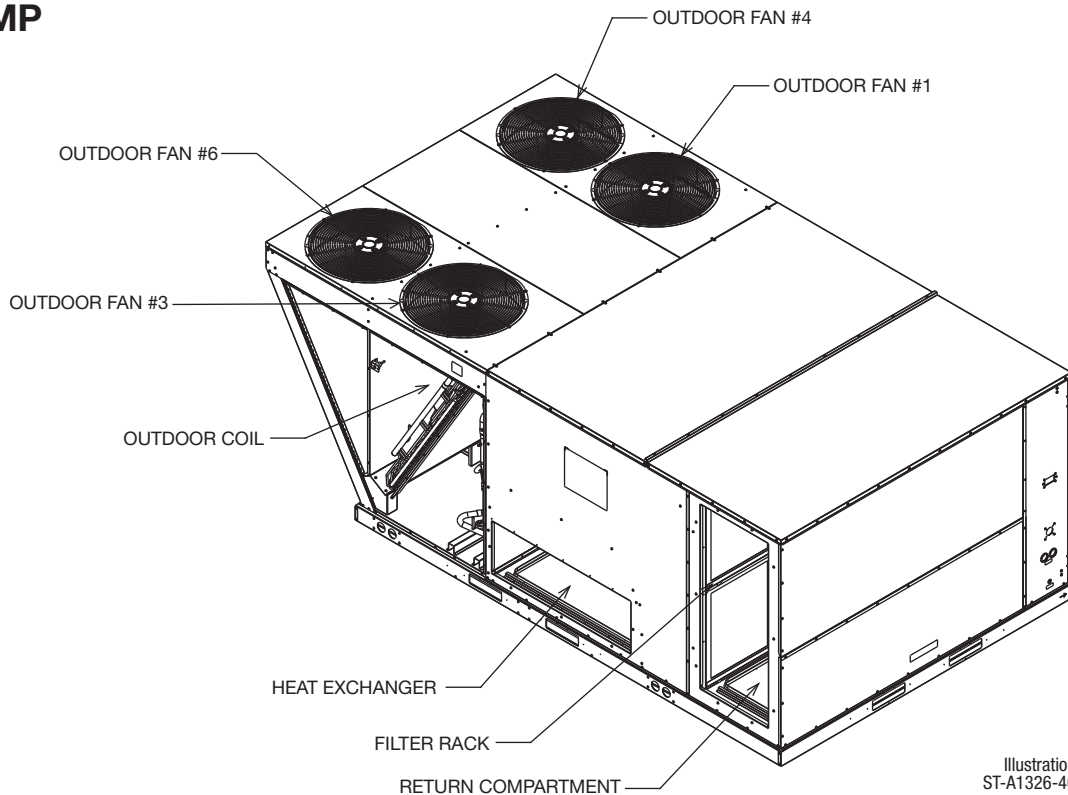
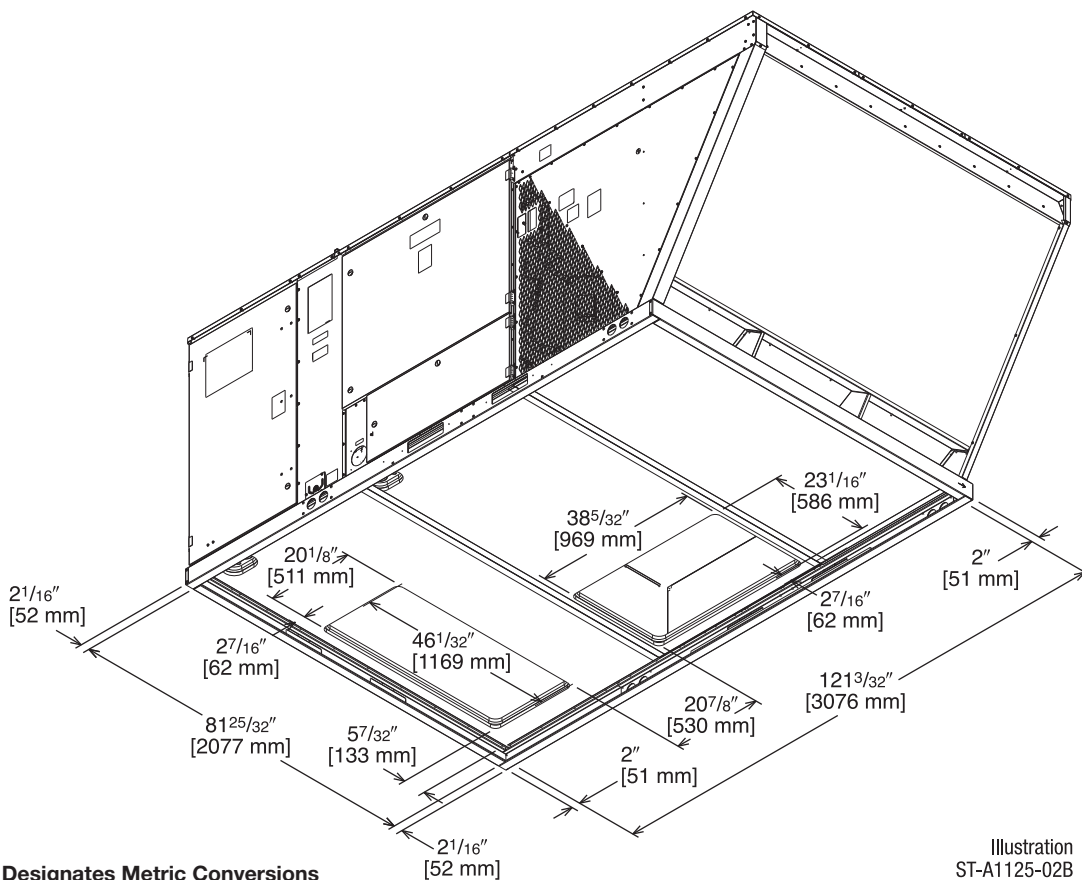

Illustration  
ST-A1326-46



## BOTTOM VIEW

[ ] Designates Metric Conversions

Illustration  
ST-A1125-02B

# SELF-CONTAINED HEAT PUMP

## SUPPLY AND RETURN DIMENSIONS FOR HORIZONTAL APPLICATIONS

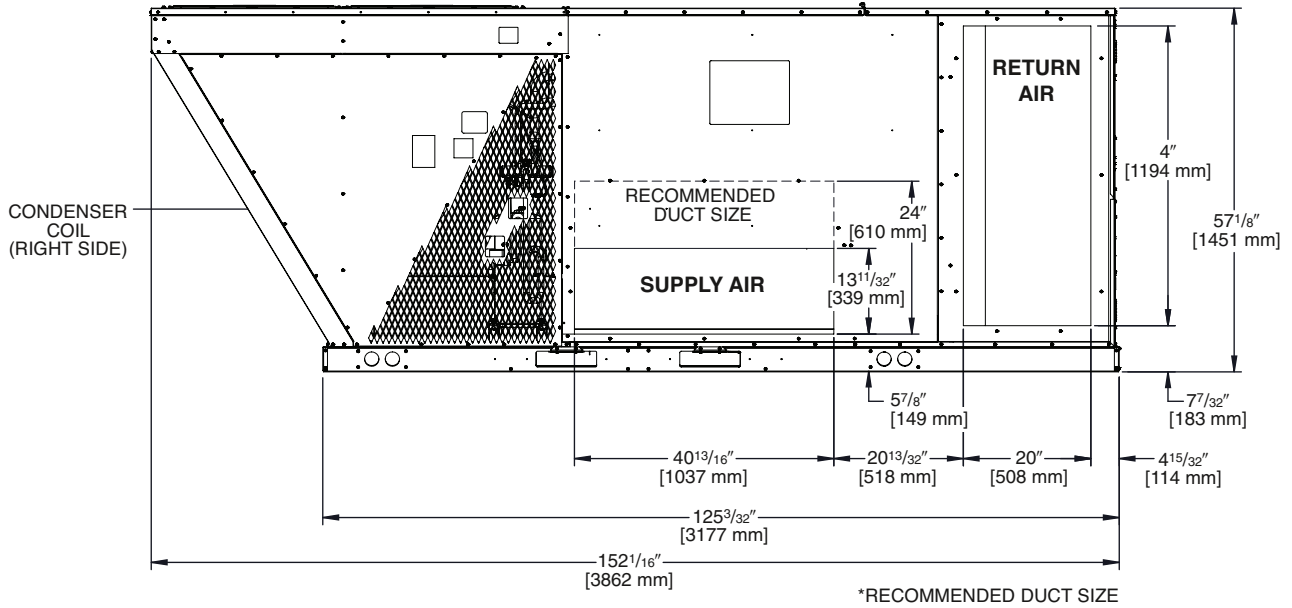

Illustration  
ST-A1326-47

## DUCT SIDE VIEW (REAR)

## SUPPLY AND RETURN DIMENSIONS FOR DOWNFLOW APPLICATIONS

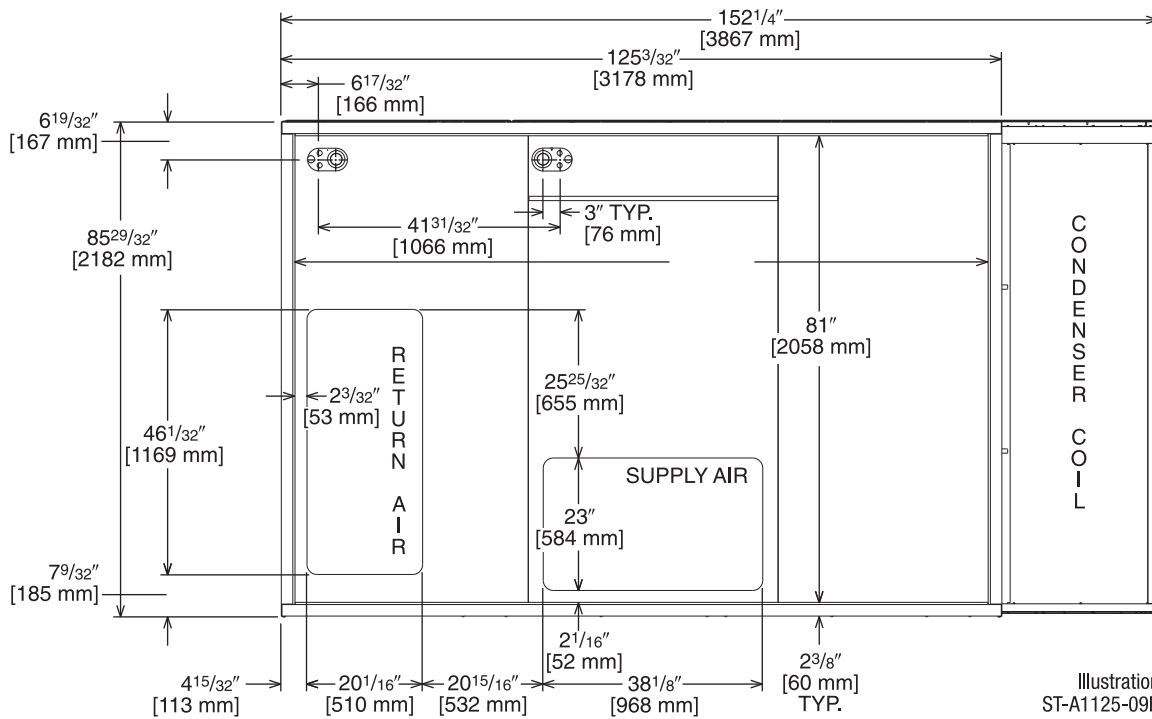
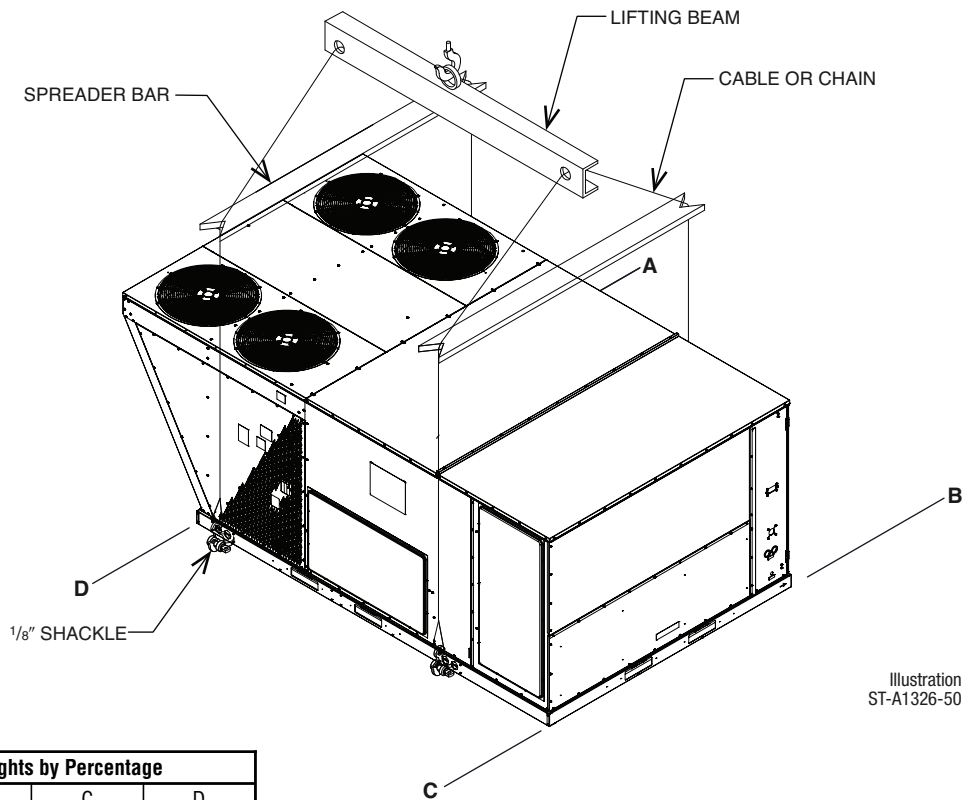
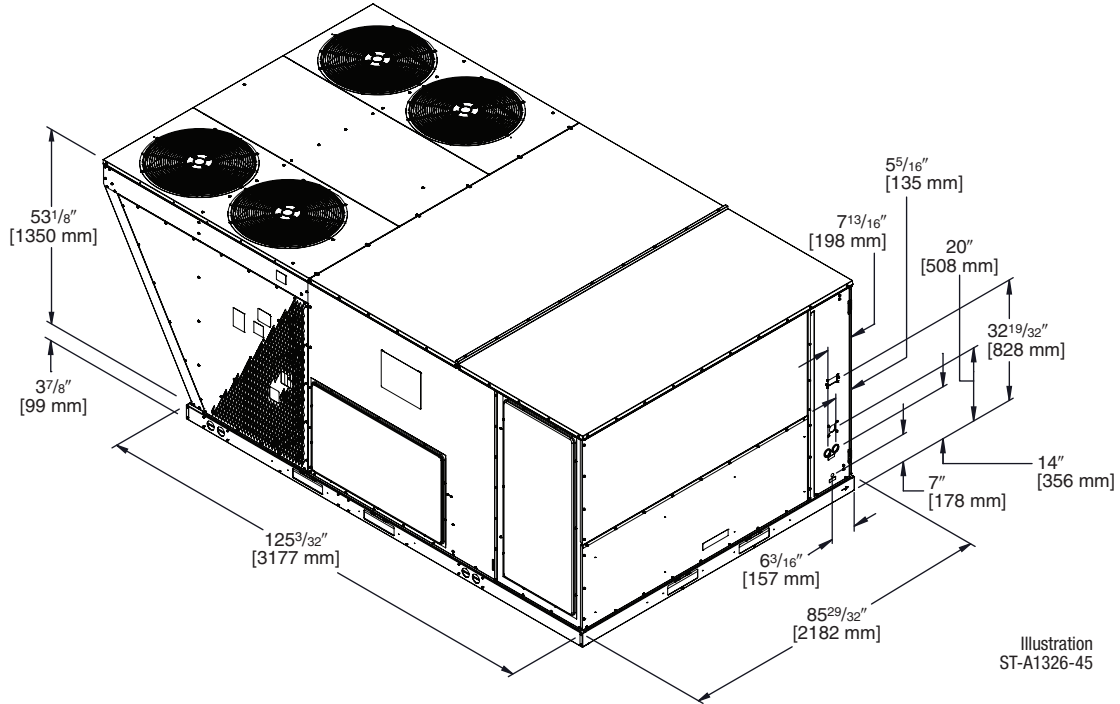

Illustration  
ST-A1125-09B

## BOTTOM VIEW

[ ] Designates Metric Conversions

# UNIT DIMENSIONS SELF-CONTAINED HEAT PUMP



## WEIGHTS

Corner Weights by Percentage			
A	B	C	D
32%	27%	16%	24%

\*Note: Corner weights measured at base of unit.

[ ] Designates Metric Conversions

# SLAB INSTALLATION

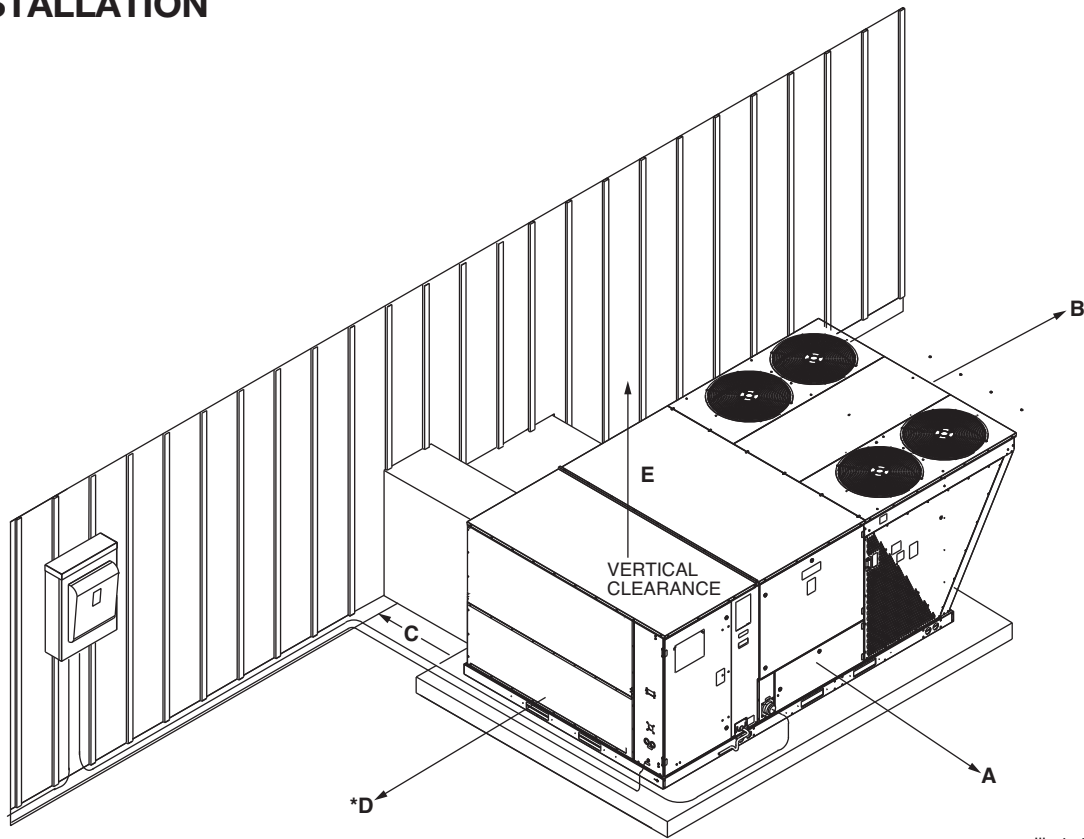

Illustration  
ST-A1326-49

## CLEARANCES

The following minimum clearances are recommended for proper unit performance and serviceability.

Recommended Clearance In. [mm]	Location
80 [2032]	A - Front
18 [457]	B - Condenser Coil
18 [457]	+C - Duct Side
18 [457]	*D - Evaporator End
60 [1524]	E - Above
*Without Economizer 18" [457 mm]. With Economizer 48" [1219 mm]. +Without Horizontal Economizer 18" [457 mm]. With Horizontal Economizer 42" [1067 mm].	

[ ] Designates Metric Conversions

## FIELD INSTALLED ACCESSORY EQUIPMENT-SELF CONTAINED HEAT PUMP

Descriptions	Model Number RHPH	Shipping Weight Lbs. [kg]	Installed Weight Lbs. [kg]	Factory Installation Available?
Electric Heaters	RXJJ-CE20 (C,D,Y)	41 [18.6]	31 [14.1]	Yes
	RXJJ-CE40 (C,D,Y)	44 [20.0]	34 [15.4]	Yes
	RXJJ-CE60 (C,D,Y)	45 [20.4]	35 [15.9]	Yes
	RXJJ-CE75 (C,D,Y)	46 [20.8]	36 [16.3]	Yes
Downflow Economizer w/Single Enthalpy (Non-DDC)	AXRD-01RGDAM3	277 [125.6]	168 [76.2]	Yes
Downflow Economizer w/Smoke Detector (DDC)	AXRD-01RMDCM3	277 [125.6]	168 [76.2]	Yes
Dual Enthalpy Kit	RXRX-AV02	1 [.5]	.5 [.2]	No
Horizontal Economizer w/Single Enthalpy (Non-DDC)	AXRD-01RGHAM3	333 [151.0]	301 [36.5]	No
Horizontal Economizer w/Smoke Detector (DDC)	AXRD-01RMHCM3	333 [151.0]	301 [36.5]	No
Carbon Dioxide Sensor (Wall Mount)	RXRX-AR02	3 [1.4]	2 [1.0]	No
Power Exhaust (208/230V)	RXRX-BGF05C	119 [53.9]	59 [26.7]	No
Power Exhaust (460V)	RXRX-BGF05D	119 [53.9]	59 [26.7]	No
Power Exhaust (575V)	RXRX-BGF05Y	119 [53.9]	59 [26.7]	No
Manual Fresh Air Damper*	AXRF-KFA1	61 [27.7]	52 [23.6]	No
Modulating Motor Kit for AXRF-KFA1	RXRF-AW05			No
2-Position Motorized Kit for Manual Fresh Air Damper*	RXRX-AW03	42 [19.1]	35 [15.9]	No
Roofcurb, 14"	RXKG-CBH14	184 [83.5]	176 [79.8]	No
Roofcurb Adapter to RXRK-E56	RXRX-CJCE56	465 [210.9]	415 [88.2]	No
Roofcurb Adapter to RXKG-CAF14	RXRX-CJCF14	555 [251.7]	505 [29.1]	No
Concentric Diffuser (Step-Down, 18" x 36")	RXRN-AD81	310 [140.6]	157 [71.2]	No
Concentric Diffuser (Step-Down, 24" x 48")	RXRN-AD86	367 [166.4]	212 [96.1]	No
Concentric Diffuser (Step-Down, 28" x 60")	RXRN-AD88	410 [186.0]	370 [67.8]	No
Concentric Diffuser (Flush, 18" x 36")	RXRN-AD80	213 [96.6]	115 [52.2]	No
Downflow Transition (Rect. to Rect., 18" x 36")	RXMC-CJ07	81 [36.7]	74 [33.6]	No
Downflow Transition (Rect. to Rect., 24" x 48")	RXMC-CK08	81 [36.7]	74 [33.6]	No
Low-Ambient Control Kit DDC (1 Per Compressor)	RXRZ-C02	3 [1.4]	2 [1.0]	Yes
Low-Ambient Control Kit Non-DDC (1 Per Compressor)	RXRZ-A05	3 [1.4]	2 [1.0]	Yes
Unwired Convenience Outlet	RXRX-AN01	2 [1.0]	1.5 [.7]	Yes
Comfort Alert (1 Per Compressor) (DDC)	RXRX-AZ01	3 [1.4]	2 [1.0]	Yes
BACnet Communication Card	RXRX-AY01	1 [0.5]	1 [0.5]	No
LonWorks Communication Card	RXRX-AY02	1 [0.5]	1 [0.5]	No
Room Humidity Sensor	RHC-ZNS4	1 [0.5]	1 [0.5]	No
Room Temperature and Relative Humidity Sensor	RHC-ZNS5	1 [0.5]	1 [0.5]	No
Hail Guard Louvers	AXRX-AAD01L	55 [24.8]	45 [20.3]	Yes
Return Smoke Detector (Downflow/Vertical)	RXRX-BSH1	7 [3.2]	6 [2.7]	Yes
Return Smoke Detector (Horizontal)	RXRX-BSH2	7 [3.2]	6 [2.7]	Yes
Return/Supply Smoke Detector (Downflow/Vertical)	RXRX-BSH3	10 [4.5]	9 [4.1]	Yes
Return/Supply Smoke Detector (Horizontal)	RXRX-BSH4	10 [4.5]	9 [4.1]	Yes
MERV 8 Filter	RXMF-M08A22520	2 [0.9]	1 [0.45]	Yes
MERV 13 Filter	RXMF-M13A22520	2 [0.9]	1 [0.45]	Yes

\*Motorized Kit and Manual Fresh Air Damper must be combined for a complete Motorized Outside Air Damper Selection.

[ ] Designates Metric Conversions

## ECONOMIZERS—DOWNFLOW ONLY

### Field Installed

**AXRD-01RGDAM3—Single Enthalpy (Outdoor) (Non-DDC)**

**RXXR-AR02—Optional Wall-Mounted CO<sub>2</sub> Sensor**

**RXXR-AV02—Dual Enthalpy Upgrade Kit**

**AXRD-01RMDCM3—With Smoke Detector (DDC)**

- Features **Honeywell** Controls
- Available Factory Installed or Field Accessory
- Gear Driven Direct Drive Actuator
- Fully Modulating (0-100%)
- Low Leakage Dampers
- Slip-In Design for Easy Installation
- Plug-In Polarized 12-pin Electrical Connections
- Pre-Configured—No Field Adjustments Necessary
- Standard Barometric Relief Damper
- Single Enthalpy with Dual Enthalpy Upgrade Kit Available
- CO<sub>2</sub> Input Sensor Available
- Field Assembled Hood Ships with Economizer
- Economizer Ships Complete for Downflow Duct Application
- Optional Remote Minimum Position Potentiometer (Honeywell #S963B1128) is Available from Prostock
- Field Installed Power Exhaust Available
- Smoke Detector optional

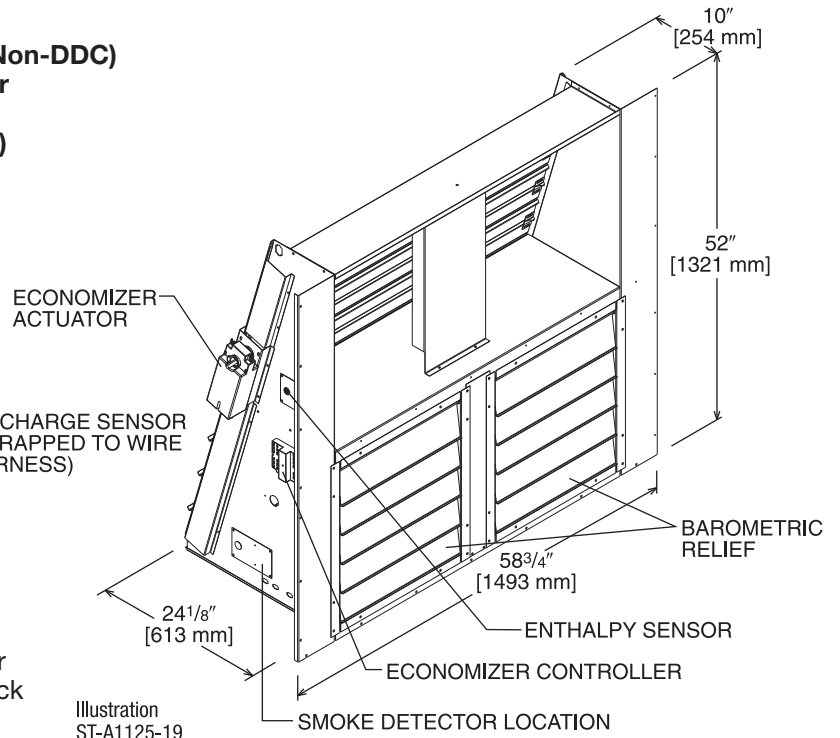

Illustration  
ST-A1125-19

TOLERANCE ±.125

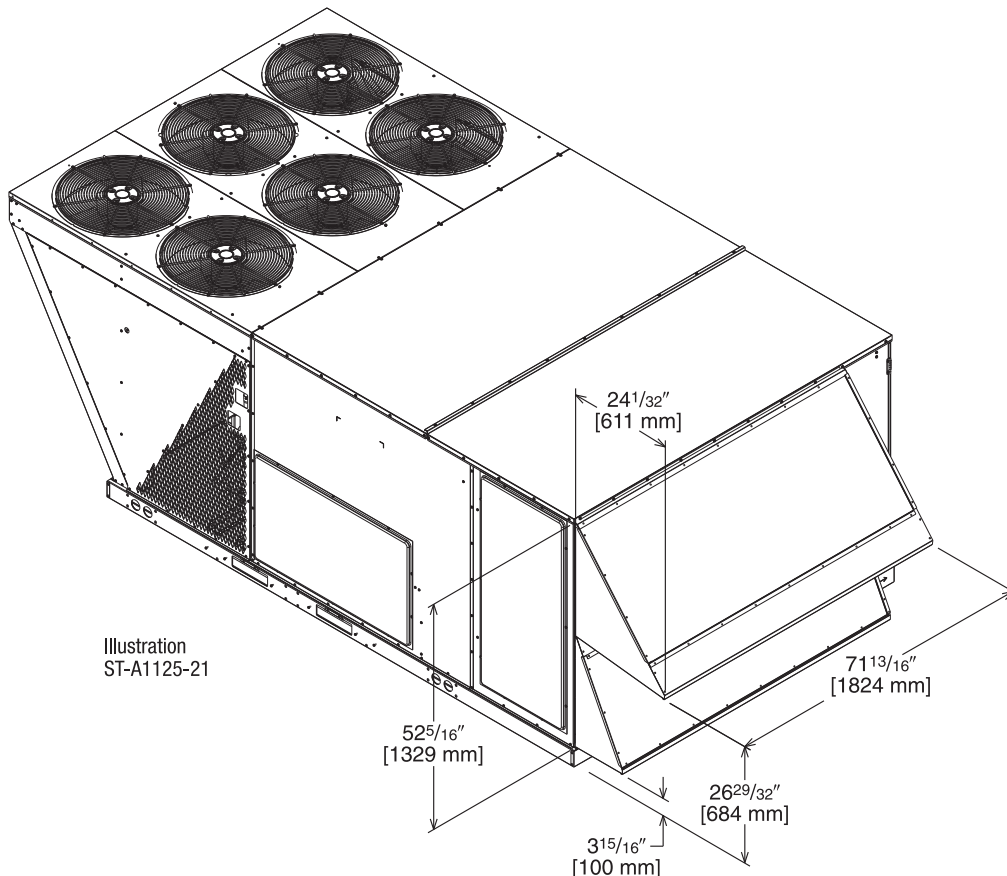

Illustration  
ST-A1125-21

[ ] Designates Metric Conversions



# ECONOMIZER FOR HORIZONTAL DUCT INSTALLATION

## Field Installed Only

**AXRD-01RGHAM3—Single Enthalpy (Outdoor) (Non-DDC)**

**RXXR-AV02—Dual Enthalpy Upgrade Kit**

**RXXR-AR02—Optional Wall-Mounted CO<sub>2</sub> Sensor**

**AXRD-01RMHCM3—With Smoke Detector (DDC)**

- Features **Honeywell** Controls
- Available as a Field Installed Accessory Only
- Gear Driven Direct Drive Actuator
- Fully Modulating (0-100%)
- Low Leakage Dampers
- Slip-In Design for Easy Installation
- Plug-In Polarized 12-pin Electrical Connections
- Pre-Configured—No Field Adjustments Necessary
- Standard Barometric Relief Damper
- Single Enthalpy with Dual Enthalpy Upgrade Kit Available
- CO<sub>2</sub> Input Sensor Available
- Field Assembled Hood Ships with Economizer
- Economizer Ships Complete for Horizontal Duct Application
- Optional Remote Minimum Position Potentiometer (Honeywell #S963B1128) is Available from Prostock
- Field Installed Power Exhaust Available
- Smoke Detector optional

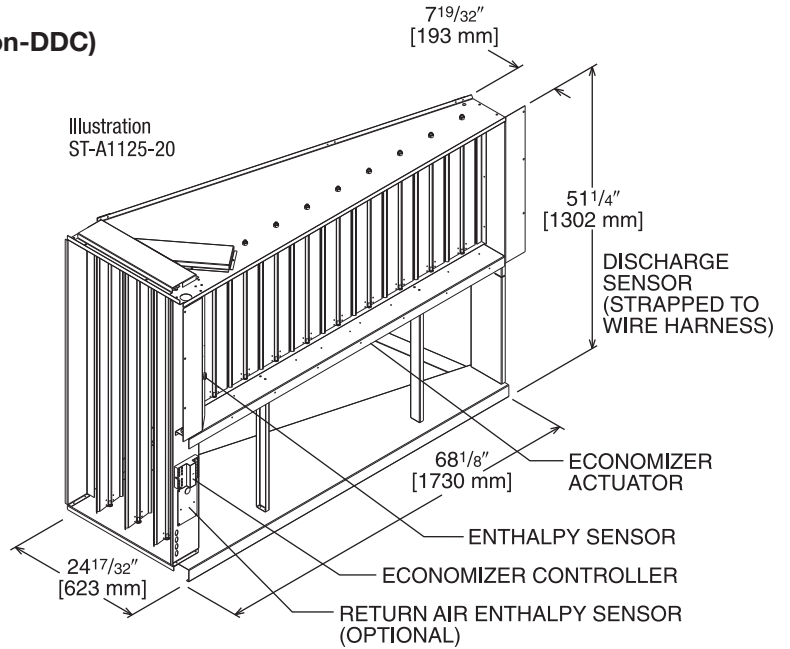

TOLERANCE  $\pm .125$

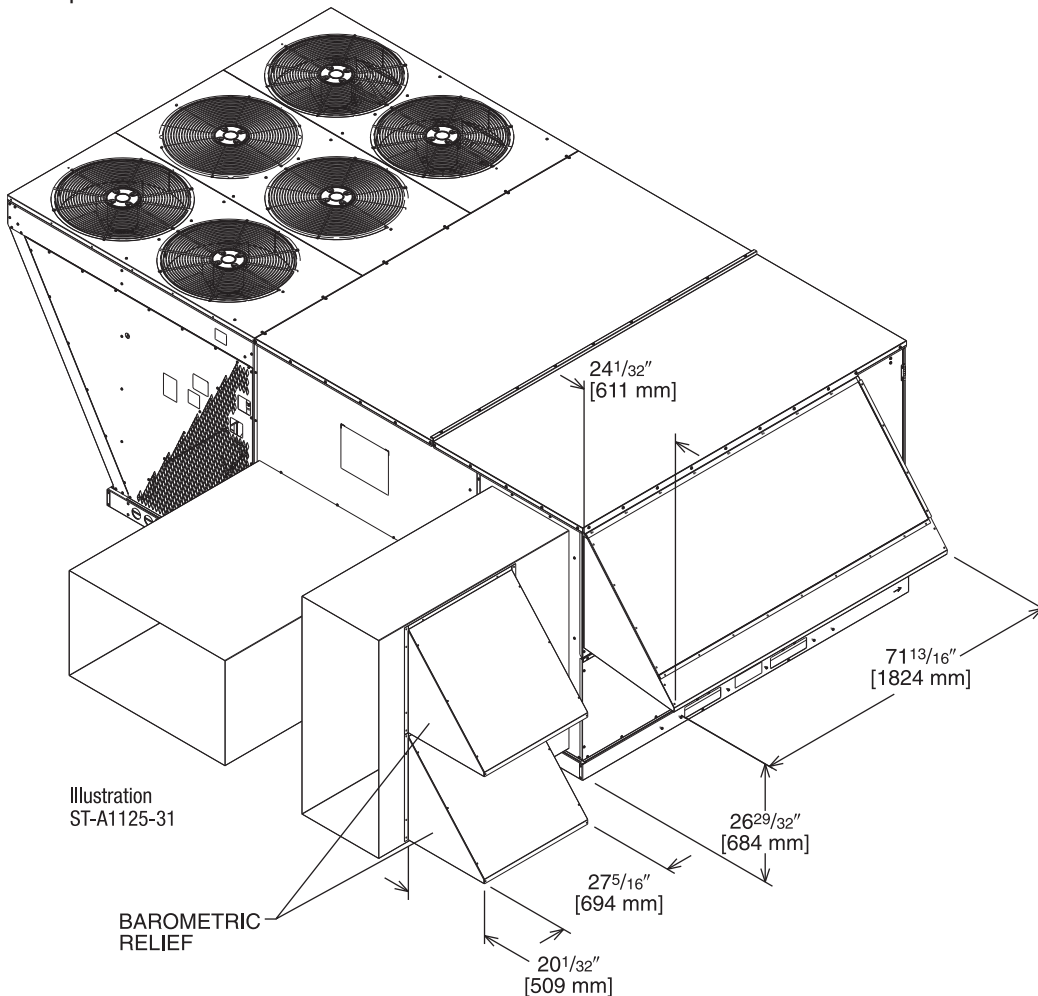

[ ] Designates Metric Conversions

# INTEGRAL POWER EXHAUST KIT FOR AXRD-PGCM3 OR SGCM3 ECONOMIZERS

RXXR-BGF05 (C, D, or Y\*)

\*Voltage Code

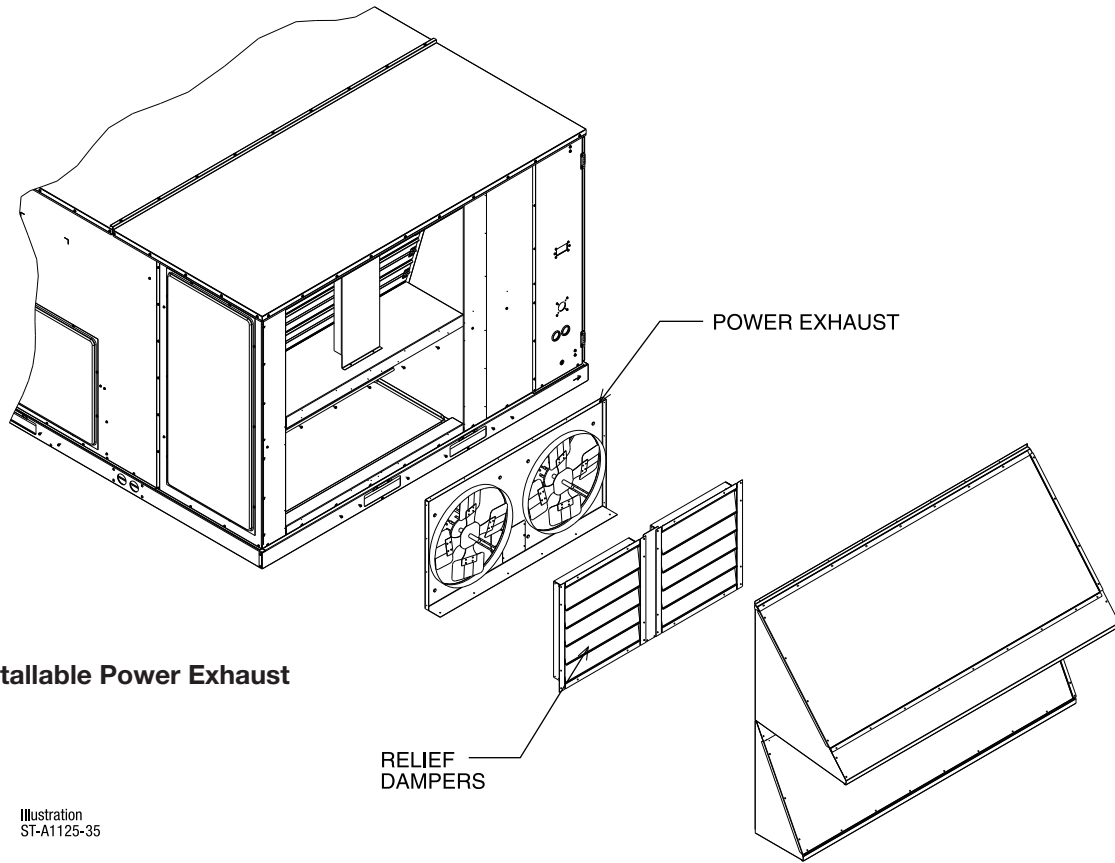

Field Installable Power Exhaust

Illustration  
ST-A1125-35

Model No.	No. of Fans	Volts	Phase	HP (ea.)	Low Speed		High Speed ①		FLA (ea.)	LRA (ea.)
					CFM [L/s] ②	RPM	CFM [L/s] ②	RPM		
RXXR-BGF05C	2	208-230	1	0.75	4100 [1935]	850	5200 [2454]	1050	5	4.97
RXXR-BGF05D	2	460	1	0.75	4100 [1935]	850	5200 [2454]	1050	2.2	3.4
RXXR-BGF05Y	2	575	1	0.75	4100 [1935]	850	5200 [2454]	1050	1.5	2.84

NOTES: ① Power exhaust is factory set on high speed motor tap.

② CFM is per fan at 0 w.c. external static pressure.

[ ] Designates Metric Conversions

## FRESH AIR DAMPER

**MOTORIZED DAMPER KIT**  
**RXRX-AW03**  
**(Motor Kit for AXRF-KFA1)**  
**RXRF-AW05**  
**(Modulating Motor Kit with**  
**position feedback for**  
**AXRF-KFA1)**

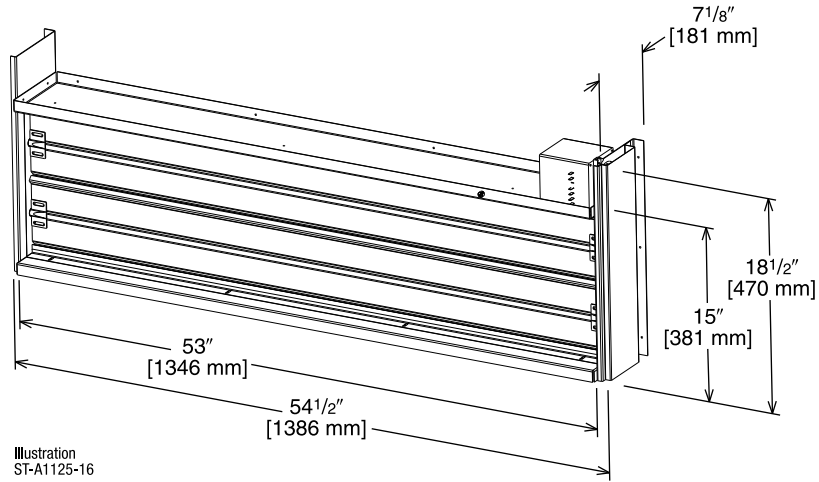

**AXRF-KFA1 (Manual)**  
**AXRX-AW03 (Motorized damper kit for**  
**manual fresh air damper)**  
**RXRF-AW05 (Modulating Motor Kit with**  
**position feedback for AXRF-KFA1)**

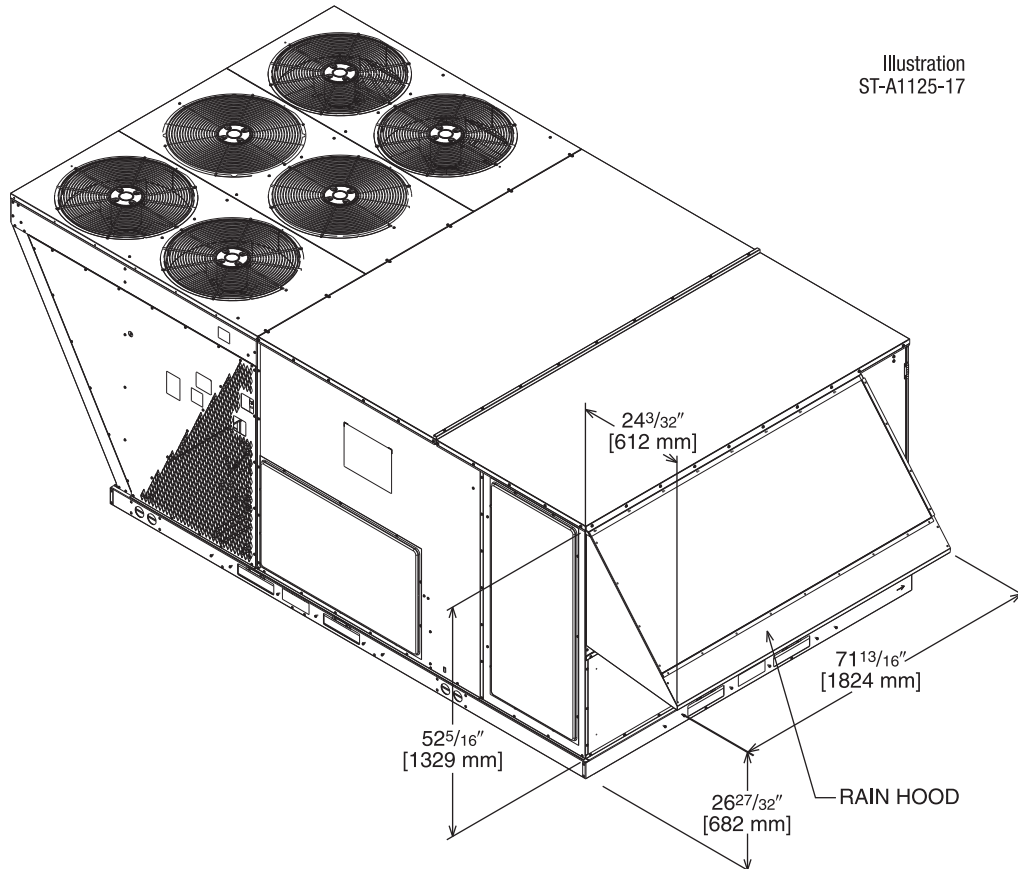

[ ] Designates Metric Conversions

## ROOFCURBS (Full Perimeter)

- One available height (14 [356 mm])
- Quick assembly corners for simple and fast assembly
- 1 [25.4 mm] x 4 [102 mm] Nailers provided
- Insulating panels not required because of insulated outdoor base pan
- Sealing gasket (28 [711 mm]) provided with Roofcurb
- Packaged for easy field assembly

### TYPICAL INSTALLATION

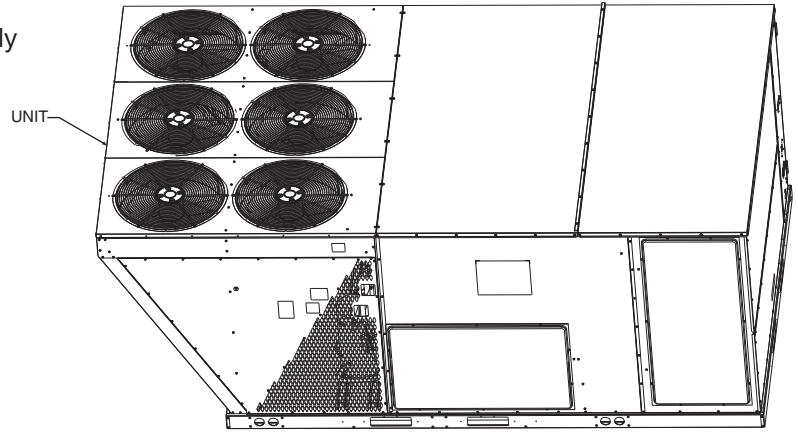

### ROOFCURB ASSEMBLY

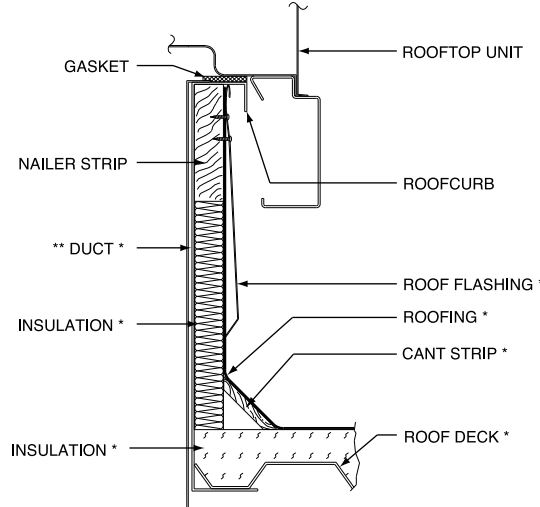
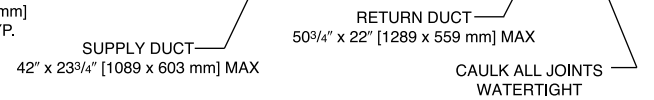
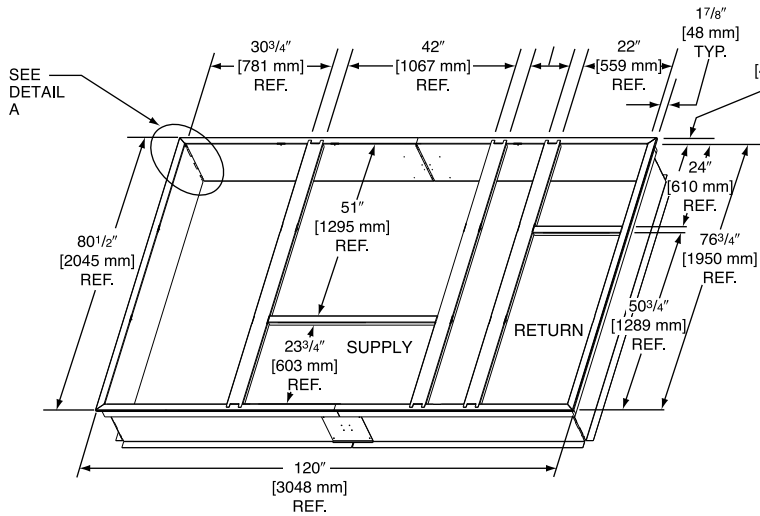
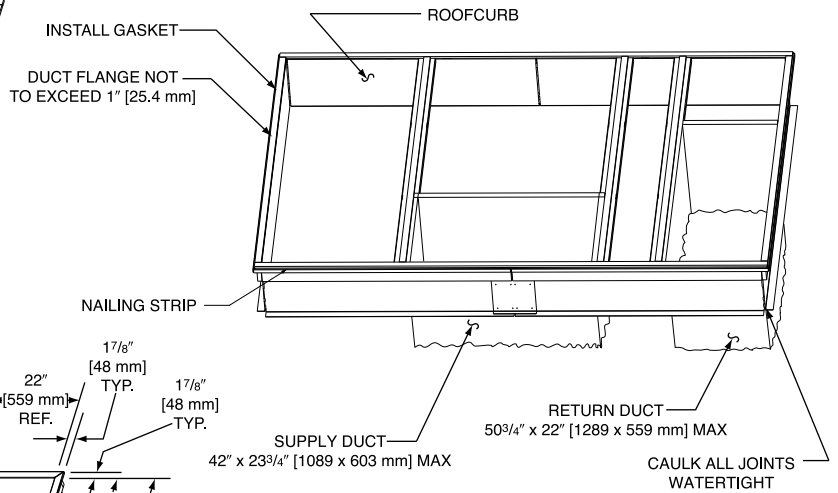
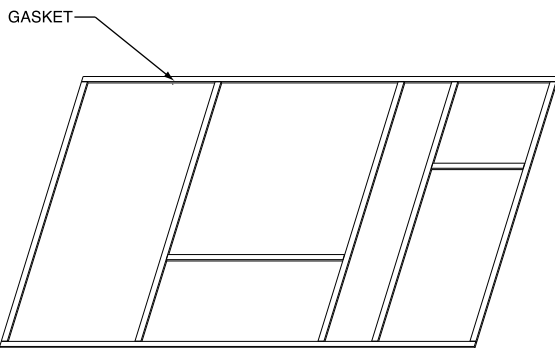

\* BY CONTRACTOR

\*\* FOR INSTALLATION OF DUCT AS SHOWN, USE RECOMMENDED DUCT SIZES FROM ROOFCURB INSTALLATION INSTRUCTIONS. FOR DUCT FLANGE ATTACHMENT TO UNIT, SEE UNIT INSTALLATION INSTRUCTIONS FOR RECOMMENDED DUCT SIZES.

Illustration  
ST-A1125-14

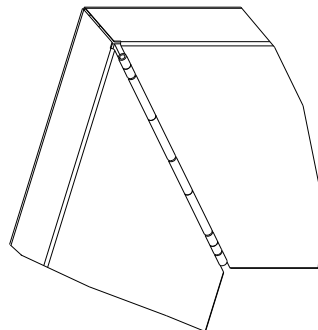

DETAIL A

[ ] Designates Metric Conversions

# ROOFCURB ADAPTERS

**OLD MODELS**

**OLD CURB MODEL**

**ROOFCURB ADAPTER**

**NEW MODEL**

**COMMERCIAL CABINET**  
(12.5, 15 & 20 TON)  
([44, 52.8 & 70.3 kW])  
(-)RCF, (-)RGF, (-)REF

RXRK-E56

RXRK-CJCE56

(-)JNL  
(15 TON)  
([52.8 kW])

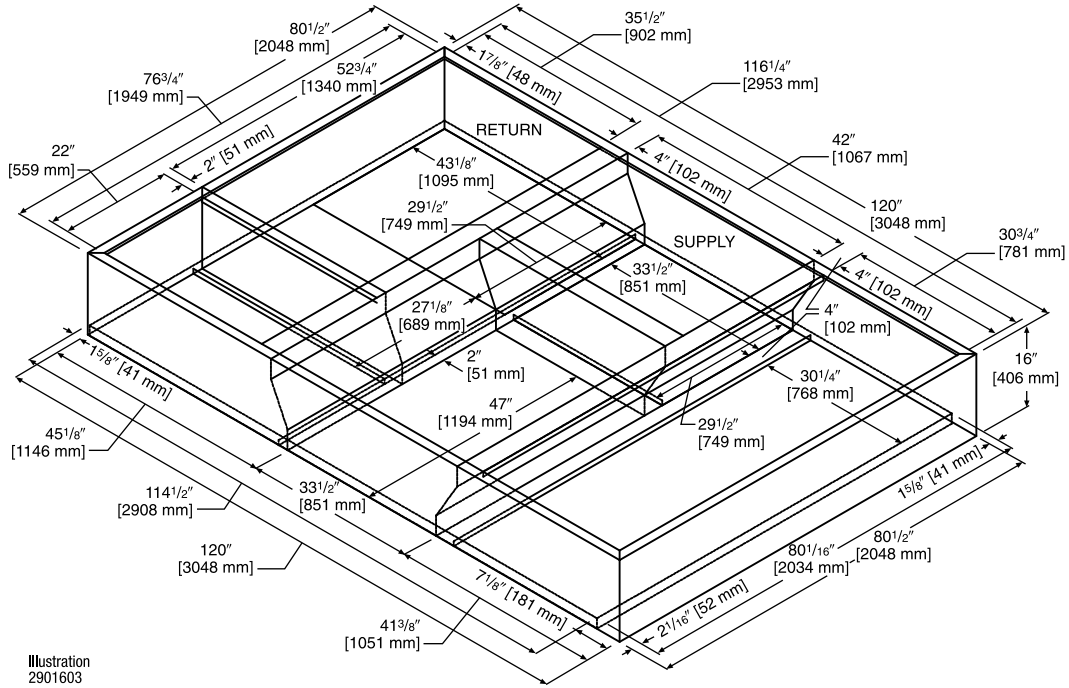

**COMMERCIAL CABINET**  
(15, 20 & 25 TON)  
([52.8, 70.3 & 87.9 kW])  
(-)LKB, LMB, LNB (COOLING ONLY)  
(-)KKB, KMB, KNB (GAS/ELECTRIC)

RXKG-CAF14

RXRK-CJCF14

(-)JNL (HEAT PUMP)  
(15 TON)  
([52.8 kW])

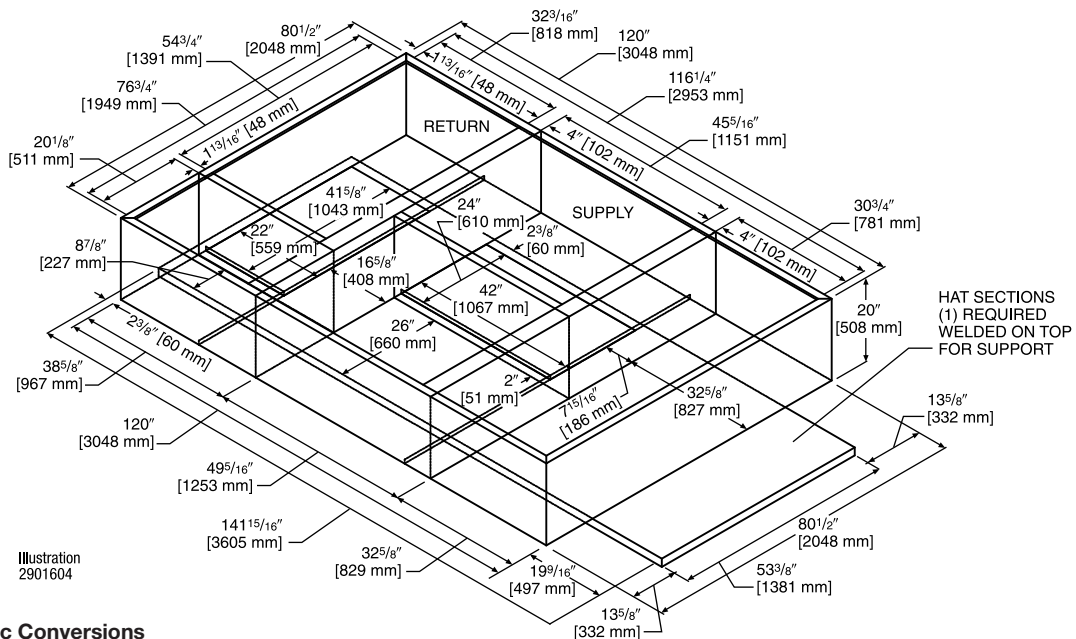

[ ] Designates Metric Conversions

## CONCENTRIC DIFFUSER APPLICATION

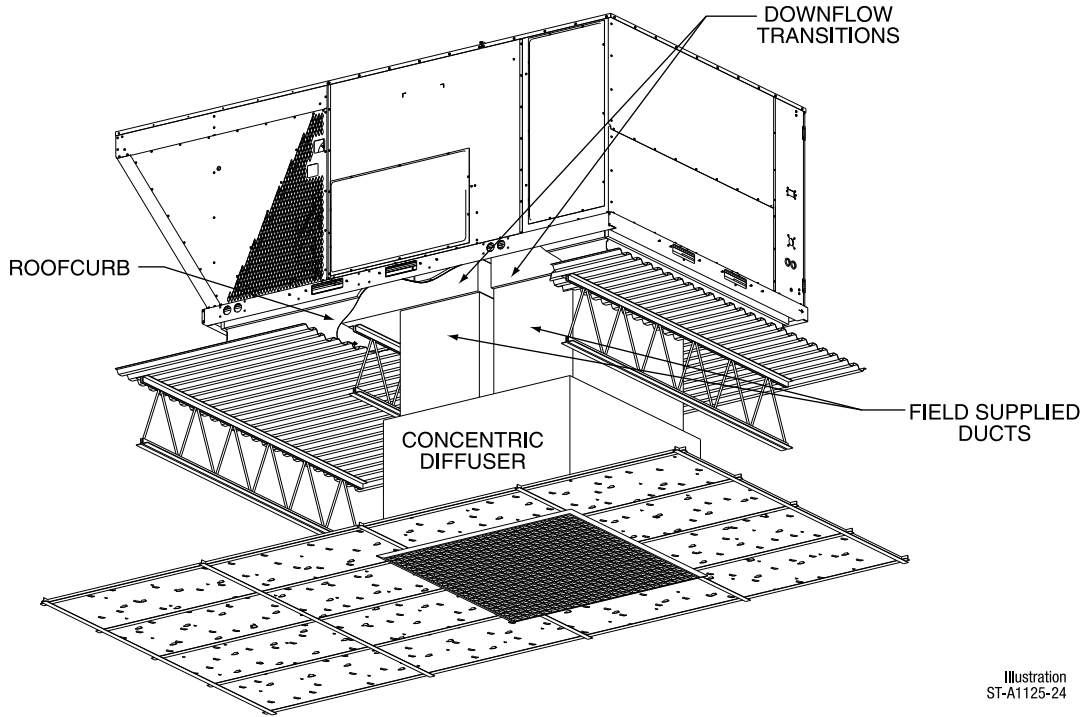

Illustration  
ST-A1125-24

## DOWNFLOW TRANSITION DRAWINGS

### RXMC-CJ07 (15 Ton) [52.8 kW]

- Used with RXRN-AD80 and RXRN-AD81 Concentric Diffusers

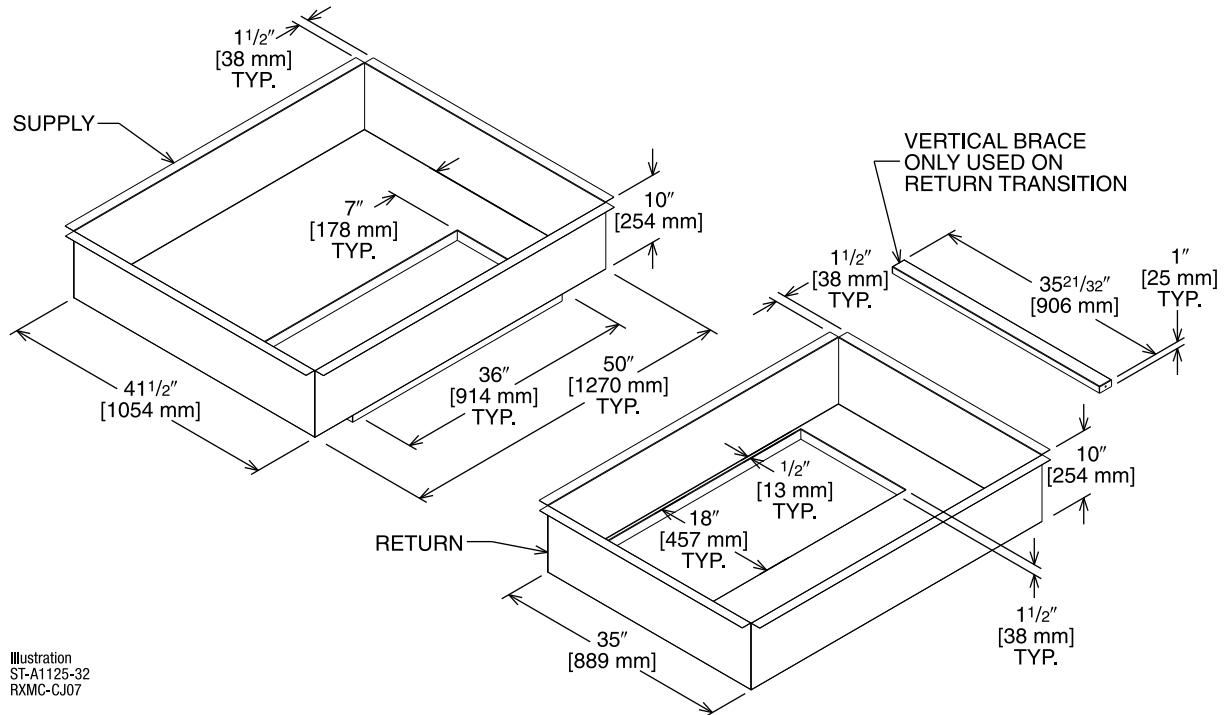
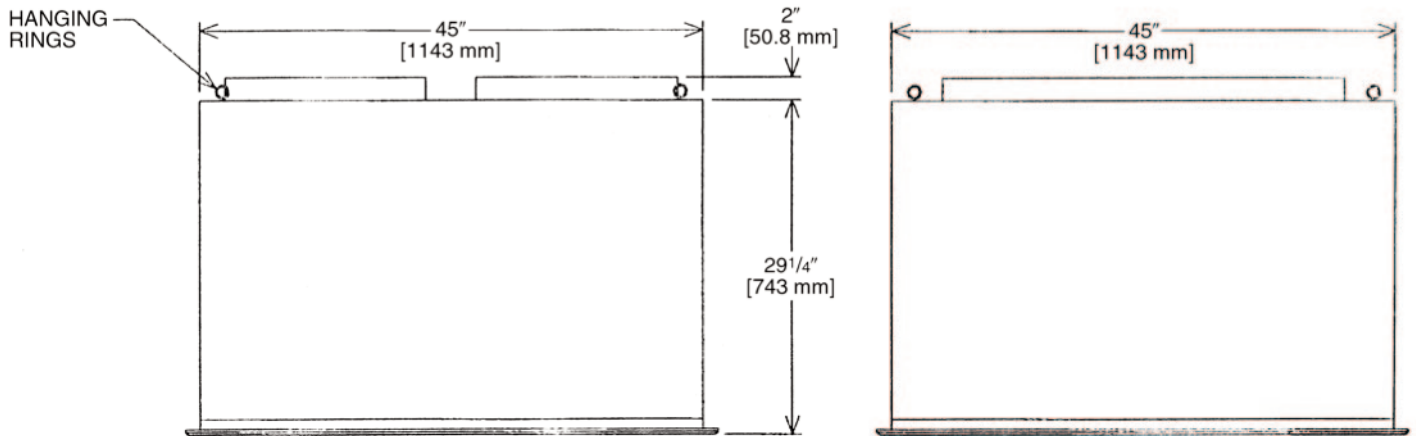
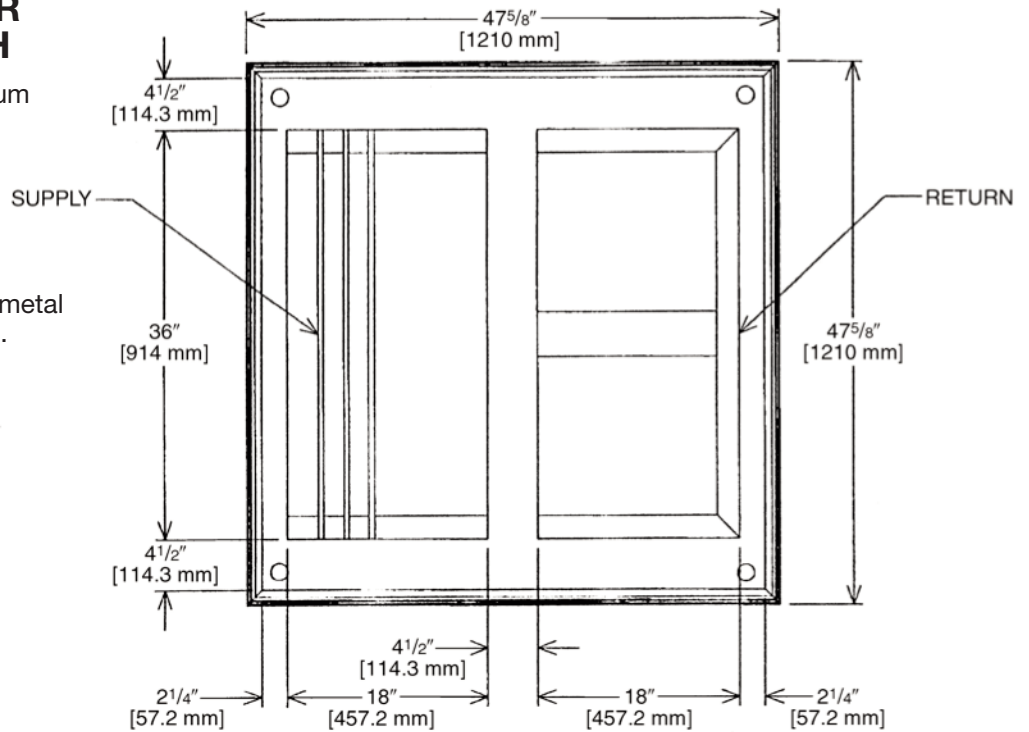

Illustration  
ST-A1125-32  
RXMC-CJ07

[ ] Designates Metric Conversions

## CONCENTRIC DIFFUSER 15 TON [52.8 kW] FLUSH

- All aluminum diffuser with aluminum return air eggcrate
- Built-in anti-sweat gasket
- Molded fiberglass supports
- Built-in hanging supports
- Diffuser box constructed of sheetmetal insulated with 1 [25.4 mm] 1.5 lbs. [.7 kg] duct liner



## CONCENTRIC DIFFUSER SPECIFICATIONS

PART NUMBER	CFM [L/s]	STATIC PRESSURE	THROW FEET	NECK VELOCITY	JET VELOCITY
RXRN-AD80	5600 [2643]	0.36	28-37	1000	2082
	5800 [2737]	0.39	29-38	1036	2156
	6000 [2832]	0.42	40-50	1071	2230
	6200 [2926]	0.46	42-51	1107	2308
	6400 [3020]	0.50	43-52	1143	2379
	6600 [3115]	0.54	45-56	1179	2454

[ ] Designates Metric Conversions

## CONCENTRIC DIFFUSER 15 TON [52.8 kW] STEP DOWN

- All aluminum diffuser with aluminum return air eggcrate
- Built-in anti-sweat gasket
- Molded fiberglass supports
- Built-in hanging supports
- Diffuser box constructed of sheetmetal insulated with 1 [25.4 mm] 1.5 lbs. [.7 kg] duct liner
- Double deflection diffuser with the blades secured by spring steel

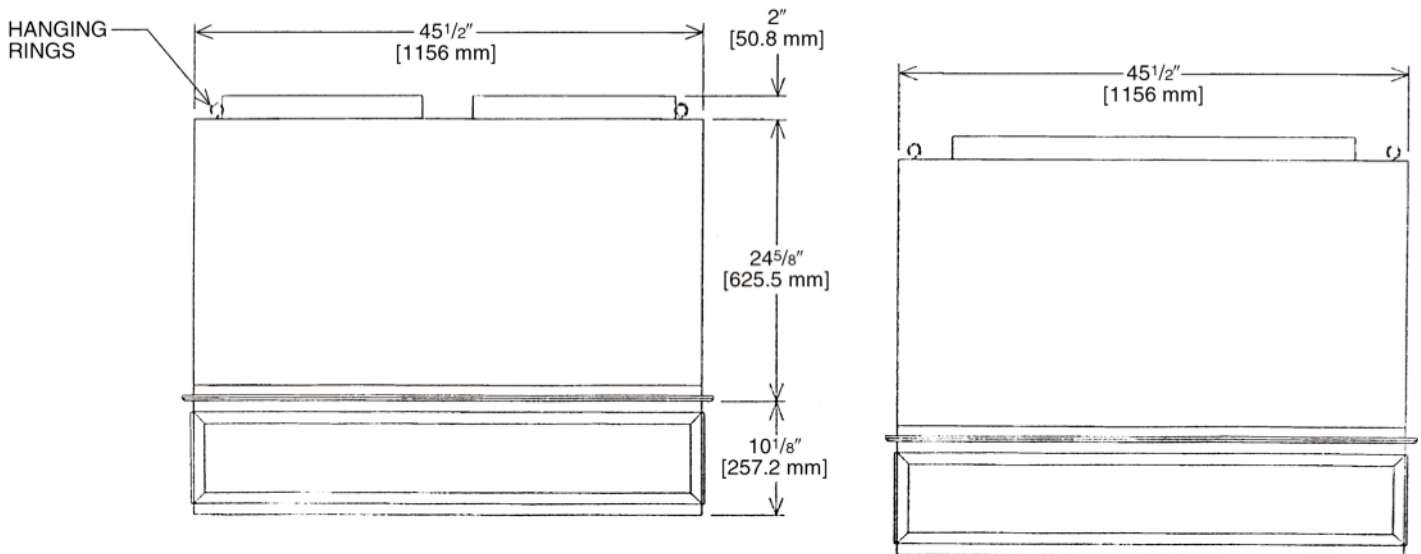
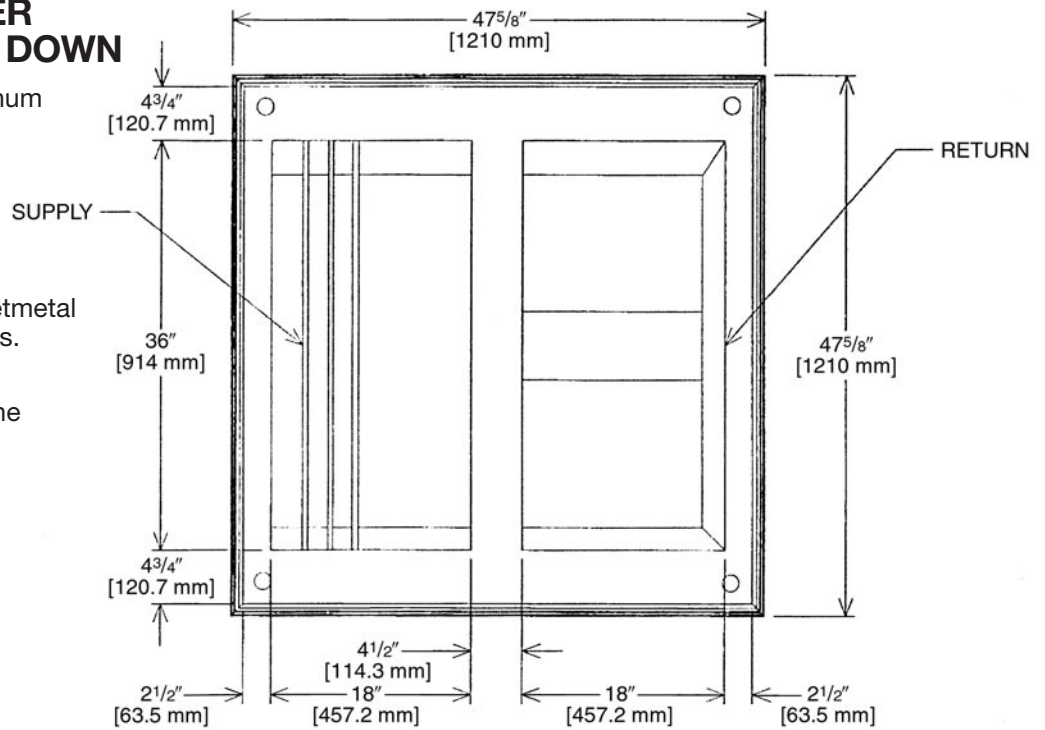

## CONCENTRIC DIFFUSER SPECIFICATIONS

PART NUMBER	CFM [L/s]	STATIC PRESSURE	THROW FEET	NECK VELOCITY	JET VELOCITY
RXRN-AD81	5600 [2643]	0.36	39-49	920	920
	5800 [2737]	0.39	42-51	954	954
	6000 [2832]	0.42	44-54	1022	1022
	6200 [2926]	0.46	45-55	1056	1056
	6400 [3020]	0.50	46-55	1090	1090
	6600 [3115]	0.54	47-56	1124	1124

[ ] Designates Metric Conversions



## Guide Specifications RHPH

You may copy this document directly into your building specification. This specification is written to comply with the 2016 version of the “master format” as published by the Construction Specification Institute. www.csinet.org.

### ELECTRIC HEAT PUMP PACKAGED ROOFTOP

#### HVAC Guide Specifications

#### Size Range: 15 Nominal Tons

<u>Section</u>	<u>Description</u>
----------------	--------------------

<b>23 06 80</b>	<b>Schedules for Decentralized HVAC Equipment</b>
-----------------	---

<b>23 06 80.13</b>	<b>Decentralized Unitary HVAC Equipment Schedule</b>
--------------------	--

23 06 80.13.A. Rooftop unit schedule

1. Schedule is per the project specification requirements.

<b>23 07 16</b>	<b>HVAC Equipment Insulation</b>
-----------------	----------------------------------

23 07 16.00.A. Evaporator fan compartment:

1. Interior cabinet surfaces shall be insulated with a minimum 1/2-in. thick, minimum 1.6 LB density, flexible fiberglass insulation bonded with foil face on the air side.
2. Insulation and adhesive shall meet NFPA 90A requirements for flame spread and smoke generation.
3. Insulation shall also be mechanically fastened with welded pin and retainer washer.

<b>23 09 13</b>	<b>Instrumentation and Control Devices for HVAC</b>
-----------------	---

<b>23 09 13.23</b>	<b>Sensors and Transmitters:</b>
--------------------	----------------------------------

23 09 13.23.A. Thermostats

1. Thermostat must
  - a. Energize both “W1” and “W2” when calling for heat on DDC, and ‘W3’ on non-DDC.
  - b. Have capability to energize 2 different stages of cooling, and 2 different stages of heating and a reversing valve output.
  - c. Must include capability for occupancy scheduling.

<b>23 09 13</b>	<b>Direct-Digital Control System for HVAC</b>
-----------------	---

23 09 23.00.A. RTU-C controller

1. Shall be ASHRAE 62-2001 compliant.
2. Shall accept 18-32VAC input power.
3. Shall have an operating temperature range from 0°F (-18°C) to 125°F (52°C), 10%– 95% RH (non-condensing).
4. Controller shall accept the following inputs: space temperature, setpoint adjustment, outdoor air temperature, indoor air quality, outdoor air enthalpy, emergency shutdown, return air enthalpy, fan status, remote time clock/door switch.
5. Shall accept a CO2 sensor in the conditioned space, and be Demand Control Ventilation (DCV) ready.
6. Shall provide the following outputs: Economizer, fan, cooling stage 1, cooling stage 2, heat stage 1, heat stage 2, exhaust, occupied.
7. Unit shall provide surge protection for the controller through a circuit breaker.
8. Shall have a field installed communication card allowing the unit to be able to communicate at a Baud rate of 19.2K or faster.
9. Shall have an LED display independently showing the status of activity on the communication bus, and processor operation.
10. Optional field installed BACnet® plug-in communication card which includes an EIA-485 protocol communication port, or an optional field installed LonWorks™ plug-in communications card.
11. Software upgrades will be accomplished by local download. Software upgrades through chip replacements are not allowed.
12. Shall be shock resistant in all planes to 5G peak, 11ms during operation, and 100G peak, 11ms during storage.
13. Shall be vibration resistant in all planes to 1.5G @ 20-300 Hz.
14. Shall support a bus length of 4000 ft max, 60 devices per 1000 ft section, and 1 RS-485 repeater per 1000 ft sections.
15. Unit shall be compatible with a programmable 24 volt thermostat.
16. Unit shall be compatible with a zone sensor and a mechanical or solid state time clock connected to the RTU-C.

23 09 23.00.B. Open protocol, direct digital controller:

1. Shall be ASHRAE 62-2001 compliant.
2. Shall accept 18-30VAC, 50-60Hz, and consumer 15VA or less power.
3. Shall have an operating temperature range from 0°F (-18°C) to 125°F (52°C), 10%– 95% RH (non-condensing).
4. Shall have either a field installed BACnet® plug-in communication card which includes an EIA-485 protocol communication port, or a field installed LonWorks™ plug-in communications card.
5. The BACnet® plug in communication card shall include built-in protocol for BACNET (MS/TP and PTP modes).
6. The LonWorks™ plug in communication card shall include the Echelon processor required for all Lon applications.
7. Shall allow access of up to 62 network variables (SNVT). Shall be compatible with all open controllers.
8. Baud rate Controller shall be selectable through the EIA-485 protocol communication port.
9. Shall have an LED display independently showing the status of serial communication, running, errors, power, all digital outputs, and all analog inputs.
10. Shall accept the following inputs: space temperature, setpoint adjustment, outdoor air temperature, indoor air quality, outdoor air enthalpy, compressor lock-out, fire shutdown, enthalpy switch, and fan status/filter status/ humidity/ remote occupancy.
11. Shall provide the following outputs: economizer, fan, cooling stage 1, cooling stage 2, heat stage 1, heat stage 2, exhaust.
12. Software upgrades will be accomplished by either local or remote download. No software upgrades through chip replacements are allowed.
13. Shall be natively equipped with Modbus communication protocol.

**23 09 33 Electric and Electronic Control System for HVAC**

23 09 33.00.A. General:

1. Shall be complete with self-contained low-voltage control circuit protected by a circuit breaker on the 24-V transformer side.
2. Shall utilize color-coded wiring.
3. Unit control board shall be provided with 7 segment readout via LCD display for status and diagnostics.
4. Shall include a central control terminal board to provide connection points conveniently and safely for vital control functions such as: smoke detectors, phase monitor, economizer, thermostat, DDC control options, loss of charge, freeze sensor, high pressure switches.
5. Unit shall include a minimum of one 10-pin screw terminal connection board for connection of control wiring.
6. Shall include integrated defrost system to prevent excessive frost accumulation during heating duty, and shall be controlled as follows:
  - a. Defrost shall be initiated on the basis of Demand Defrost.
  - b. The need for a defrost cycle is determined by one of two factors: Time or Frost Detection.
  - c. Should six hours of compressor run time elapse without a defrost cycle and the coil temperature is below the frost accumulation temperature, a defrost cycle will be initiated.
  - d. The control shall be capable of detecting frost accumulation on the outdoor coil and initiate a defrost cycle when necessary.

23 09 33.00.B. Safeties:

1. Compressor over-temperature, over current.
2. Standard Low-pressure switch.
  - a. Units shall have low pressure, loss of charge automatic reset device that will shut off compressor when tripped.
  - b. Low pressure control:
    - i. Provides active protection in both heating and cooling modes at all outdoor ambient temperatures. The low pressure control is an automatic reset type and opens at approximately 15 psig and closes at approximately 40 psig. Operation is slightly different between cooling and heating modes.
3. Standard High-pressure switch.
  - a. Unit shall be equipped with high pressure switch device that will shut off compressor when tripped.
  - b. High Pressure control:
    - i. The high pressure control is an automatic reset type and opens at approximately 650 psig and closes at approximately 420 psig. The compressor and fan motor will stop when the high pressure control opens and will start again if the high side pressure drops to approximately 420 psig where the automatic reset high pressure control resets. If the high pressure control opens 3 times within a particular call for heating or cooling operation, the defrost control will lock out compressor and outdoor fan operation.
7. Freeze protection sensor, evaporator. Freeze protection sensor is a standard feature for all DDC units and optional for Non-DDC units.
8. Automatic reset, motor thermal overload protector.

**23 09 93 Sequence of Operations for HVAC Controls**

**23 09 93.00 INSERT SEQUENCE OF OPERATION**

**23 41 13 Panel Air Filters**

23 41 13.00.A. Standard Filter section shall:

1. Shall consist of factory-installed, low velocity, throwaway 2-in. thick fiberglass filters of commercially available sizes.
2. Compatible with 2-in MERV 8 and MERV 13 filters.
3. Unit will accept only 2-in. filters.
4. Filter face velocity shall not exceed 365 fpm at nominal airflows.
5. Filters shall be accessible through an access panel as described in the unit cabinet of the specification (23 81 19.13.H).

**23 81 19 Self-Contained Heat Pumps**

**23 81 19.13 Small Capacity Self-Contained Heat Pumps**

23 81 19.13.A. General

1. Outdoor, rooftop mounted, electrically controlled, heating and cooling unit utilizing two hermetic scroll compressor(s) for cooling duty and heating duty.
2. Factory assembled, single-piece heating and cooling rooftop unit. Contained within the unit enclosure shall be all factory wiring, piping, controls, and special features required prior to field start-up.
3. Unit shall use environmentally safe, R410A refrigerant.
4. Unit shall be installed in accordance with the manufacturer's instructions.
5. Unit must be selected and installed in compliance with local, state, and federal codes.
6. Model and serial data shall be reprinted inside the control box.

23 81 19.13.B. Quality Assurance

1. Unit meets ASHRAE 90.1 2019 minimum efficiency requirements.
2. Unit shall be rated in accordance with AHRI Standards 340/360.
3. Unit shall be designed to conform to ASHRAE 15.
4. Unit shall be UL-tested and certified in accordance with Standards and UL-listed and certified under Canadian standards as a total package for safety requirements.
5. Insulation and adhesive shall meet NFPA 90A requirements for flame spread and smoke generation.
6. Unit casing shall be capable of withstanding Federal Test Method Standard No. 141 (Method 6061) 500-hour salt spray.
7. Unit shall be designed in accordance with ISO 9001:2015, and shall be manufactured in a facility registered by ISO 9001:2015.
8. Roof curb shall be designed to conform to NRCA Standards.
9. Unit shall be subjected to an automated run test on the assembly line. The data for each unit will be stored at the factory and must be available upon request.
10. Unit shall be designed in accordance with UL Standard 1995, Fifth Ed. including tested to withstand rain.
11. Five (5) years warranty for 3 phase, commercial applications compressor.
12. One (1) year warranty for 3 phase, commercial application parts.

23 81 19.13.C. Delivery, Storage, and Handling

1. Unit shall be stored and handled per manufacturer's recommendations.
2. Lifted by crane requires either shipping top panel or spreader bars.
3. Unit shall only be stored or positioned in the upright position.
4. Wooden bumpers for handling and protection of unit during transportation and storage.

23 81 19.13.E. Project Conditions

1. As specified in the contract.

23 81 19.13.F. Operating Characteristics

1. Unit shall be capable of starting and running at 125°F (52°C) ambient outdoor temperature, meeting maximum load criteria of AHRI Standard 340/360 at  $\pm 10\%$  voltage.
2. Compressor with standard controls shall be capable of operation down to 50°F (10°C), ambient outdoor temperatures. Low ambient accessory kit is necessary if mechanically cooling at ambient temperatures to 0°F (-17.7°C).
3. Unit shall discharge supply air vertically or horizontally as shown on contract drawings.
4. Unit shall be factory configured for vertical supply & return configurations.
5. Unit shall be field convertible from vertical to horizontal configuration.

23 81 19.13.G. Electrical Requirements

1. Main power supply voltage, phase, and frequency must match those required by the manufacturer.

23 81 19.13.H. Unit Cabinet

1. Unit cabinet shall be constructed of galvanized steel, and shall be bonderized and coated with a baked enamel finish on all externally exposed surfaces.
2. Unit cabinet exterior paint shall be: film thickness, (dry) 0.003 inches minimum, gloss (per ASTM D523,60F): 60, Hardness: H-2H Pencil hardness.
3. Evaporator fan compartment interior cabinet insulation shall conform to AHRI Standards 340/360 minimum exterior sweat criteria. Interior surfaces shall be insulated with a minimum 1/2-in. thick, 1.6 lb density, flexible fiberglass insulation, foil faced on the air side.
4. Shall utilize uniform screw sizing.
5. Base of unit shall have a location for thru-the-base gas and electrical connections standard.
6. Base Rail
  - a. Unit shall have base rails on all sides.
  - b. Holes shall be provided in the base rails for rigging shackles to facilitate maneuvering and overhead rigging.
  - c. Holes shall be provided in the base rail for moving the rooftop for fork truck.
  - d. Base rail shall be a minimum of 14 gauge thickness.
7. Condensate pan and connections:
  - a. Shall be a sloped condensate drain pan made of a non-corrosive material and be removable for cleaning.
  - b. Shall comply with ASHRAE Standard 62.
  - c. Shall use a 1" NPT drain connection, possible either through the bottom or side of the drain pan. Connection shall be made per manufacturer's recommendations.
  - d. Shall be able to slide out completely.
  - e. Shall be separate from the coil.
8. Standard factory installed condensate overflow sensor.
9. Top panel:
  - a. Shall be a single piece top panel over indoor section.
10. Electrical Connections
  - a. All unit power wiring shall enter unit cabinet a single, factory-prepared, knockout location.
  - b. Thru-the-base capability
    - i. Standard unit shall have a thru-the-base electrical location(s) using a raised, continuous raised flange opening in the basepan.
    - ii. No basepan penetration, other than those authorized by the manufacturer, is permitted.
  - c. Factory standard phase-monitor on Non-DDC models and optional on DDC models.
11. Component access panels (standard)
  - a. Cabinet panels shall be easily opened for servicing.
  - b. Stainless steel metal hinges are optional on all doors.
  - c. Panels covering control box, indoor fan, indoor fan motor, gas components (where applicable), and filters shall have hinges with 1/4 turn fasteners on units with factory-installed hinged option.

23 81 19.13.J. Coils

1. Standard Aluminum/Copper Coils:
  - a. Standard evaporator and condenser coils shall have aluminum lanced plate fins mechanically bonded to seamless internally grooved copper tubes with all joints brazed.
  - b. Evaporator and condenser coils shall be leak tested to 150 psig, pressure tested to 550 psig, and qualified to UL 1995 burst test at 2,200 psi.

23 81 19.13.K. Refrigerant Components

1. Refrigerant circuit shall include the following control, safety, and maintenance features:
  - a. TXV metering system shall prevent mal-distribution of two-phase refrigerant.
  - b. Thermal Expansion Valve (TXV).
  - c. Refrigerant filter drier.
  - d. Service gauge connections on suction, liquid, and discharge lines.
  - e. Access panels can be removed without disrupting condenser air flow.

2. Compressors

- a. Unit shall use two fully hermetic scroll compressor.
- b. Compressor motors shall be cooled by refrigerant gas passing through motor windings.
- c. Compressors shall be internally protected from high discharge temperature conditions.
- d. Compressors shall be protected from an over-temperature and over-amperage conditions by an internal, motor overload device.
- e. Compressor shall be factory mounted on rubber grommets.
- f. Compressor lockout sensor on the unit controller is factory set at 35°F and is adjustable from 30°F (-1°C) to 50°F (10°C) and resets the cooling lockout at 5°F (+2.7°C) above the set point.

23 81 19.13.L. Filter Section

1. Filters access is specified in the unit cabinet section of this specification.
2. Filters shall be held in place by sliding filter tray, facilitating easy removal and installation metal rods, facilitating easy removal and installation.
3. Shall consist of factory-installed, low velocity, throw-away 2-in. thick fiberglass filters.
4. Optional field-installed MERV 8 and MERV 13 filters.
5. Filter face velocity shall not exceed 365 fpm at nominal airflows.
6. Filters shall be standard, commercially available sizes.
7. Only one size filter per unit is allowed.

23 81 19.13.M. Evaporator Fan and Motor

1. Evaporator fan motor:
  - a. Shall have permanently lubricated bearings.
  - b. Shall have inherent automatic-reset thermal overload protection.
  - a. Shall have a maximum continuous bhp rating for continuous duty operation; no safety factors above that rating shall be required.
2. Belt-Driven Evaporator Fan:
  - a. Belt drive shall include an adjustable-pitch motor pulley.
  - b. Shall use sealed, permanently lubricated ball-bearing type.
  - c. Blower fan shall be double-inlet type with forward curved blades.
  - d. Shall be constructed from steel with a corrosion resistant finish and dynamically balanced.
1. Blower Assembly
  - a. Entire assembly shall be able to slide out completely including VFD, two blowers, and motor.
  - b. Shall be able to slide-out without the removal of the roof and condenser fan motors.

23 81 19.13.N. Condenser Fans and Motors

1. Condenser fan motors:
  - a. Shall be a totally enclosed motor.
  - b. Shall use permanently lubricated bearings.
  - c. Shall have inherent thermal overload protection with an automatic reset feature.
  - d. Shall use a shaft-down design. Shaft-up designs including those with "rain-slinger devices" shall not be allowed.
2. Condenser Fans shall:
  - a. Shall be a direct-driven propeller type fan.
  - b. Shall have blades riveted to corrosion-resistant steel spiders and shall be dynamically balanced.

23 81 19.13.O. Special Features

1. Integrated Economizers:
  - a. Integrated, gear-driven parallel modulating blade design type capable of simultaneous economizer and compressor operation.
  - b. Independent modules for vertical or horizontal return configurations shall be available. Vertical return modules shall be available as a factory installed option.
  - c. Damper blades shall be galvanized steel with metal gears. Plastic or composite blades on intake or return shall not be acceptable.

- d. Shall include all hardware and controls to provide free cooling with outdoor air when temperature and/or humidity are below setpoints.
  - e. Shall be equipped with gear driven dampers for both the outdoor ventilation air and the return air for positive air stream control.
  - f. Shall be equipped with low-leakage dampers, not to exceed 2% leakage at 1 in. wg pressure differential.
  - g. Shall be capable of introducing up to 100% outdoor air.
  - h. Shall be equipped with a barometric relief damper capable of relieving up to 100% return air, depending on the airflow.
  - i. Shall be designed to close damper(s) during loss-of-power situations with spring return built into motor.
  - j. An outdoor single enthalpy sensor shall be provided as standard. Outdoor air sensor setpoint shall be adjustable and shall range from the enthalpy equivalent of 63°F @ 50% rh to 73°F @ 50% rh. Additional sensor options shall be available as accessories.
  - k. The economizer controller shall also provide control of an accessory power exhaust unit function. Factory set at 70%, with a range of 0% to 100%.
  - l. The economizer shall maintain minimum airflow into the building during occupied period and provide design ventilation rate for full occupancy.
  - m. Dampers shall be completely closed when the unit is in the unoccupied mode.
  - n. Economizer controller shall accept a 2-10Vdc CO2 sensor input for IAQ/DCV control. In this mode, dampers shall modulate the outdoor-air damper to provide ventilation based on the sensor input.
  - o. Actuator shall be directly coupled to economizer gear. No linkage arms or control rods shall be acceptable.
  - p. Economizer controller shall provide indications when in free cooling mode, in the DCV mode, or the exhaust fan contact is closed.
  - q. Economizer wire harness will have provision for smoke detector available in supply and return options.
2. Two-Position Motorized Damper
- a. Damper shall be a Two-Position Motorized Damper. Damper travel shall be from the full closed position to the field adjustable %-open setpoint.
  - b. Damper shall include adjustable damper travel from 25% to 100% (full open).
  - c. Damper shall include single or dual blade, gear driven dampers and actuator motor.
  - d. Actuator shall be directly coupled to damper gear. No linkage arms or control rods shall be acceptable.
  - e. Damper will admit up to 50% outdoor air for applicable rooftop units.
  - f. Damper shall close upon indoor (evaporator) fan shutoff and/or loss of power.
  - g. The damper actuator shall plug into the rooftop unit's wiring harness plug. No hard wiring shall be required.
  - h. Outside air hood shall include aluminum water entrainment filter.
3. Manual damper
- a. Manual damper package shall consist of damper, air inlet screen, and rain hood which can be preset to admit up to 50% outdoor air for year round ventilation.
4. Condenser Coil Hail Guard Assembly
- a. Shall protect against damage from hail.
  - b. Shall be louvered style.
5. Unit-Mounted, Non-Fused Disconnect Switch:
- a. Switch shall be factory or field installed.
  - b. Switch shall be internally mounted with external access.
  - c. National Electric Code (NEC) and UL approved non-fused switch shall provide unit power shutoff.
  - d. Shall be accessible from outside the unit.
  - e. Shall provide local shutdown.
6. Convenience Outlet:
- a. Non-Powered convenience outlet.
  - b. Outlet shall be powered from a separate 115-120v power source.
  - c. A transformer shall not be included.
  - d. Outlet shall be field-installed and internally mounted with easily accessible 115-v female receptacle.
  - e. Outlet shall include 15 amp GFI receptacle with independent fuse protection.
  - f. Outlet shall be accessible from outside the unit.

7. Propeller Power Exhaust:
  - a. Power exhaust shall be used in conjunction with an integrated economizer.
  - b. Configurable for vertical or horizontal installation.
  - c. Horizontal power exhaust is shall be mounted in return ductwork.
  - d. Power exhaust shall be controlled by economizer controller operation. Exhaust fans shall be energized when dampers open past the 0-100% adjustable setpoint on the economizer control.
  - e. Capable of constant volume.
8. Roof Curbs (Vertical):
  - a. Formed galvanized steel with wood nailer strip and shall be capable of supporting entire unit weight.
  - b. Permits installation and securing of ductwork to curb prior to mounting unit on the curb.
  - c. Shall be available in heights of 14", 18", and 24".
9. Outdoor Air Enthalpy Sensor:
  - a. The outdoor air enthalpy sensor shall be used to provide single enthalpy control. When used in conjunction with a return air enthalpy sensor, the unit will provide differential enthalpy control. The sensor allows the unit to determine if outside air is suitable for free cooling.
10. Return Air Enthalpy Sensor:
  - a. The return air enthalpy sensor shall be used in conjunction with an outdoor air enthalpy sensor to provide differential enthalpy control.
11. Indoor Air Quality (CO<sub>2</sub>) Sensor:
  - a. Shall be able to provide demand ventilation indoor air quality (IAQ) control.
  - b. The IAQ sensor shall be available in duct mount, wall mount, or wall mount with LED display. The set point shall have adjustment capability.
12. Smoke detectors:
  - a. Shall be a Four-Wire Controller and Detector.
  - b. Shall be environmental compensated with differential sensing for reliable, stable, and drift-free sensitivity.
  - c. Shall use magnet-activated test/reset sensor switches.
  - d. Shall have tool-less connection terminal access.
  - e. Shall have a recessed momentary switch for testing and resetting the detector.
  - f. Controller shall include:
    - One set of normally open alarm initiation contacts for connection to an initiating device circuit on a fire alarm control panel.
    - Two Form-C auxiliary alarm relays for interface with rooftop unit or other equipment.
    - One Form-C supervision (trouble) relay to control the operation of the Trouble LED on a remote test/reset station.
    - Capable of direct connection to two individual detector modules.
    - Can be wired to up to 14 other duct smoke detectors for multiple fan shutdown applications.
13. Electric Heat:
  - a. Heating Section
    - Heater element open coil resistance wire, nickel-chrome alloy, strung through ceramic insulators mounted on metal frame. Coil ends are staked and welded to terminal screw slots.
    - Heater assemblies are provided with integral fusing for protection of internal heater circuits not exceeding 48 amps each. Auto reset thermo limit controls, magnetic heater contactors (24 v coil) and terminal block all mounted in electric heater control box (minimum 18 ga galvanized steel) attached to end of heater assembly.

26 29 23.12. Adjustable Frequency Drive

1. Unit shall be supplied with an electronic variable frequency drive for the supply air fan.
2. Drive shall be factory installed in an enclosed cabinet.
3. Drive shall meet UL Standard 95-5V.
4. The completed unit assembly shall be UL listed.
5. Drives are to be accessible through an access panel [optional hinged doors].
6. The unit manufacturer shall install all power and control wiring.
7. The supply air fan drive output shall be controlled by the factory installed main unit control system and drive status and operating speed shall be monitored and displayed at the blower.
8. Drive shall be programmed and factory run tested in the unit.

**BEFORE PURCHASING THIS APPLIANCE, READ IMPORTANT ENERGY COST AND EFFICIENCY INFORMATION AVAILABLE FROM YOUR RETAILER.**

**GENERAL TERMS OF LIMITED WARRANTY\***

Friedrich® will furnish a replacement for any part of this product which fails in normal use and service within the applicable periods stated, in accordance with the terms of the limited warranty.

<b>Compressor</b>	
3 Phase, Commercial Applications .....	Five (5) Years
<b>Parts</b>	
3 Phase, Commercial Applications .....	One (1) Year

\*For complete details of the Limited and Conditional Warranties, including applicable terms and conditions, contact your local contractor or the Manufacturer for a copy of the product warranty certificate.









**Before proceeding with installation, refer to installation instructions packaged with each model, as well as complying with all Federal, State, Provincial, and Local codes, regulations, and practices.**

© 2023 Rheem Manufacturing Company. Friedrich trademarks owned by Rheem Manufacturing Company.

*In keeping with its policy of continuous progress and product improvement, Friedrich reserves the right to make changes without notice.*

Friedrich • 5600 Old Greenwood Road  
Fort Smith, Arkansas 72908 • [www.friedrich.com](http://www.friedrich.com)

Friedrich • 125 Edgeware Road, Unit 1  
Brampton, Ontario • L6Y 0P5