



FRIEDRICH

1 8 8 3

**Friedrich® Commercial Heat Pump
Air Handler**



RHCLP Series

Nominal Size 7.5 & 10 Tons [26.4 & 35.2 kW]



TABLE OF CONTENTS

Unit Features.....	3
Model Number Identification	4
Component Location	5
Unit Dimensions	5
Physical Data/Drive Package Data	6
Airflow Performance	7-8
Performance Data	9-11
Electric Heater Kits and Electric Data.....	12
Piping.....	13
Accessories	14-15
Guide Specifications	16
Limited Warranty	17



CABINET—The pre-painted, sheet-metal cabinet uses 18-gauge material for structural components with an underlying coat of G60 electro deposition powder coating that is tested to withstand a rigorous 500-hour salt spray test, per ASTM B117.

MOTOR—Inherently protected motors are mounted inside of insulated cabinet to reduce motor noise. A choice of motor horsepower and drive combinations are available to allow you to meet specified CFM at various static pressures up to 2" [.498 kPa] external static pressure.

LOW PROFILE—Allows for horizontal installation in most standard drop ceiling applications, and the movement of units through most standard doorways for addition or replacement work.

THERMAL EXPANSION VALVES—Standard all models.

FILTERS—One inch [25 mm] throwaway filters are standard, but filter racks are designed to accept either one inch [25 mm] or two inch [51 mm] filters. MERV 13 & MERV 8 filters are available as an accessory.

EVAPORATOR COIL—Two circuit, interlaced row split coils are constructed with copper tubes and aluminum fins mechanically bonded to the tubes for maximum heat transfer capabilities. All coil assemblies are leak tested up to 450 PSIG [3100 kPa] internal pressure prior to installation into units.

REFRIGERANT CONNECTIONS—Field piping connections are made through a fixed post between two side access panels on either side of the unit. Allows flexibility to meet most field conditions as well as full accessibility after the installation is complete. Units may be used with two straight cool condensing units or single circuit manifolded in the field using the copper fittings shipped with each unit.

VARIABLE FREQUENCY DRIVE—Provides 2-stage airflow for improved part load efficiency. Meets California Title 24 requirements.

DRAIN PAN—The galvanized steel drain pan is designed to trap condensate in either vertical or horizontal installations. Condensate drain connections are located on both sides of the unit allowing complete flexibility to meet most field conditions.

SERVICE ACCESS—Two removable panels on top and each side of the unit are easily removed for access to motors, blowers, sheaves, and filters.

HORIZONTAL OR VERTICAL—All models are designed for either application and can be installed in either position as supplied from the factory.

TESTING—All units are run tested at the factory prior to shipment. Units are shipped with a holding charge of nitrogen.

HEAT PUMP—The RHCLP Air Handler is designed for heat pump applications. It has two TX valves with internal check valves that allow reverse flow to occur, providing superior control during heating and cooling cycles. The RHCLP Air Handler has been rated and certified to operate with matching size RPCL heat pumps.

[] Designates Metric Conversions

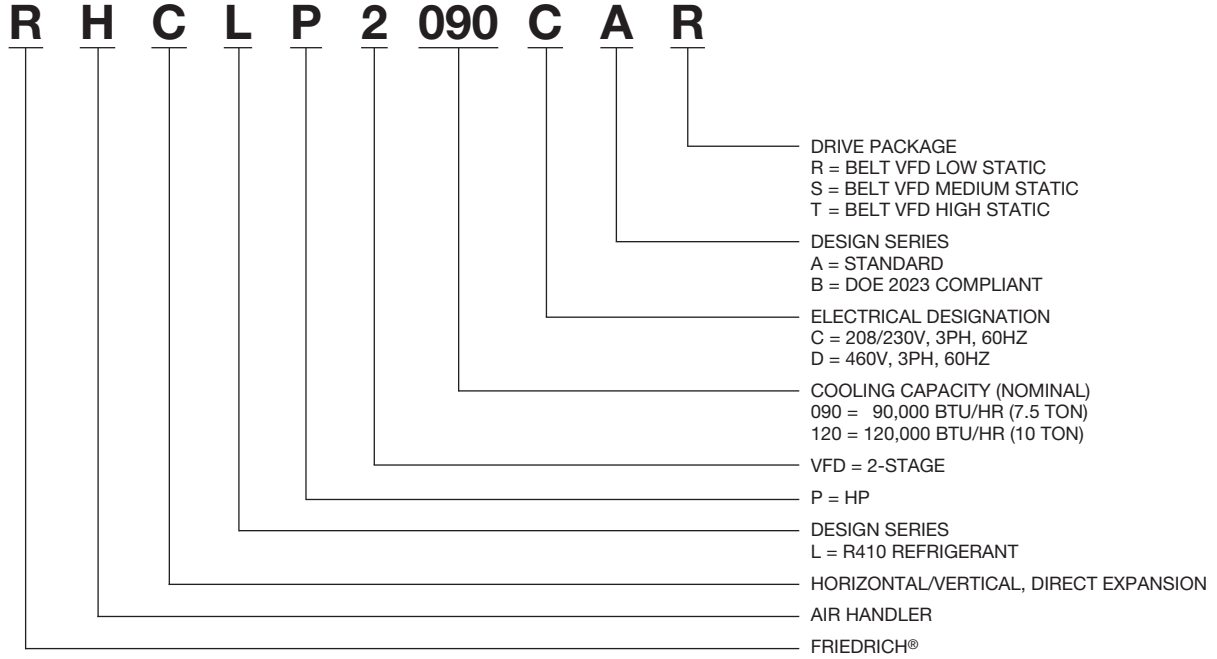

[] Designates Metric Conversions

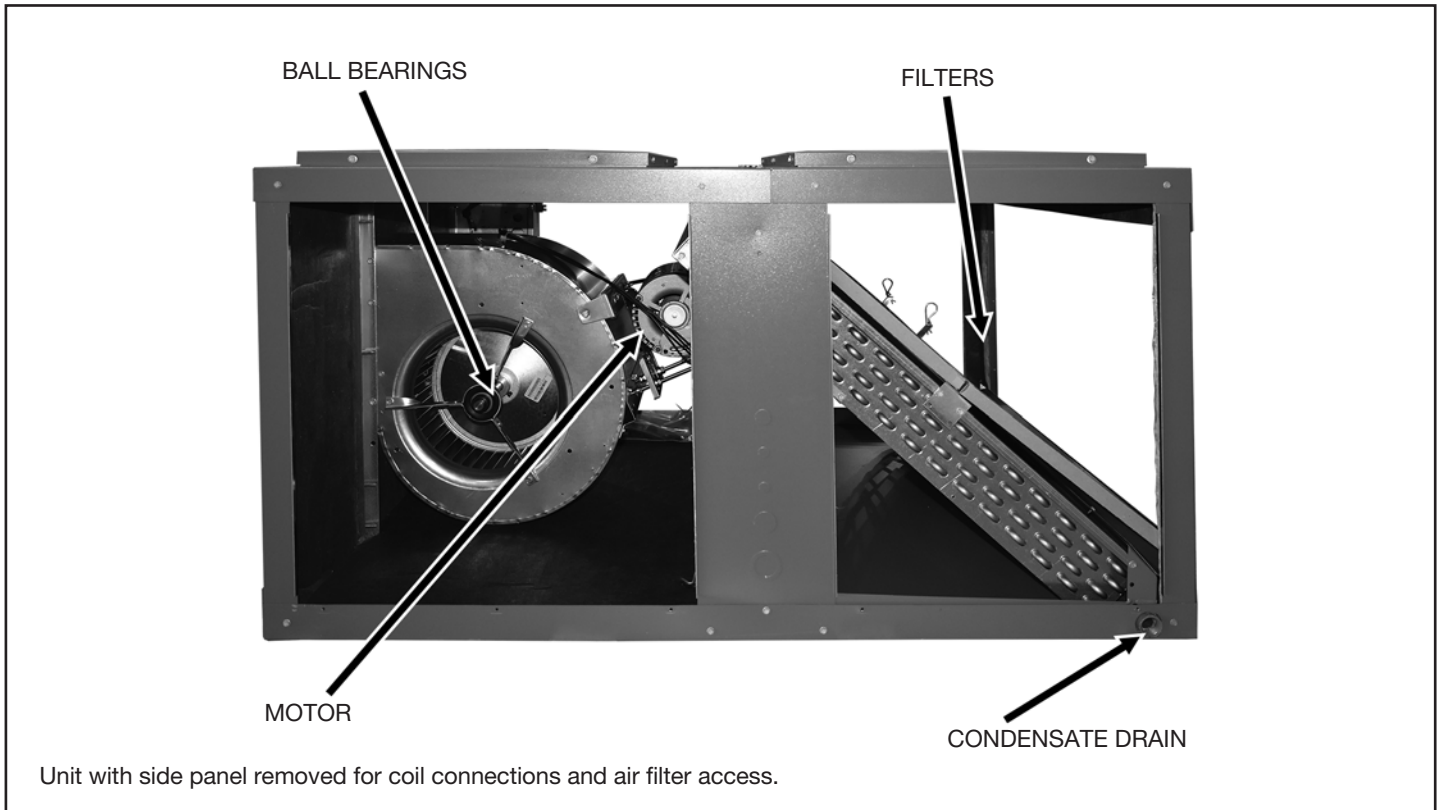

Unit with side panel removed for coil connections and air filter access.

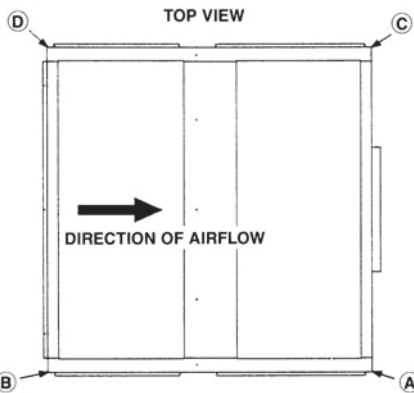

RETURN AIR OPENINGS = 47⁹/₈" [1203] WIDTH x 19⁷/₈" [505] HEIGHT

7.5 & 10 NOMINAL TONS [26.4 & 35.2 kW]

REFRIGERANT STUB SIZES, IN. [mm]				
MODEL	DUAL LIQ.	DUAL SUC.	SINGLE LIQ.	SINGLE SUC.
090	1/2, 1/2 [13, 13]	7/8, 7/8 [22, 22]	1/2 [13]	1 1/8 [29]
120	1/2, 1/2 [13, 13]	7/8, 7/8 [22, 22]	5/8 [16]	1 3/8 [35]

MODEL	REFRIGERANT STUB SIZES, IN. [mm]				TOTAL WEIGHT	GROSS WEIGHT
	A	B	C	D		
090	127 [57]	57 [25]	50 [22]	131 [59]	365 [165]	409 [185]
120	127 [57]	57 [25]	50 [22]	131 [59]	365 [165]	409 [185]

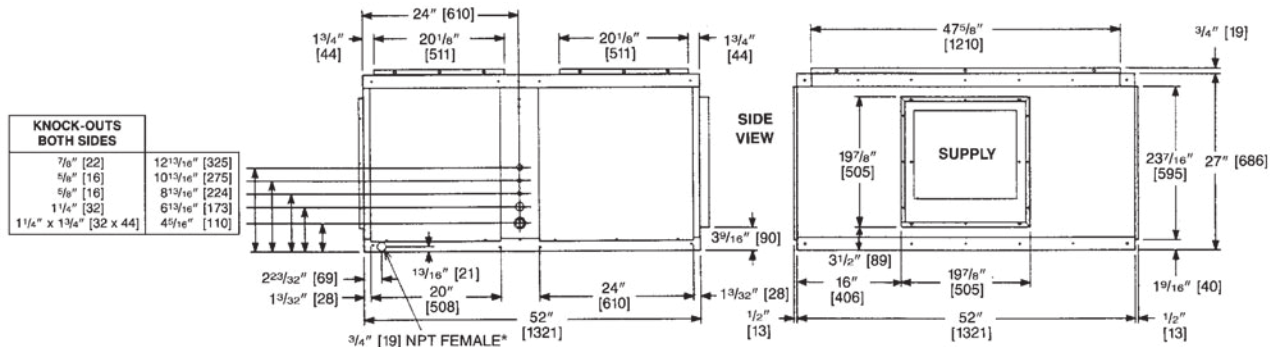

*Drain connections are provided on both sides of the drain pan. The drain can be connected to either side of the drain pan, but not both. The drain must be trapped.

[] Designates Metric Conversions

		RHCLP	
Cooling Size		090	120
Nominal size (tons)		7-1/2	10
Nominal CFM @ Rated E.S.P. (2nd Stage)		3000 @ .25"	4000 @ .30"
# of Blower Speeds		2	2
1st Stage Blower RPM %		63%	66%
MOTOR HORSEPOWER	Standard— 1750 RPM 3 phase	2 HP	2 HP
	Optional— 1750 RPM 3 phase	2 HP, 3 HP	2 HP, 3 HP
Blower Size—diameter x width		12 X 12	12 X 12
Blower Shaft Diameter		3/4	3/4
Motor Sheave	1750 RPM 3 phase	1VP50	AVL40
Belt Type & Size Std.		A-50	A-52
Coil Face Area (sq. ft.)		10.2	12.6
Coil Tube Diameter		3/8	3/8
Coil, Rows Deep-Fins Per Inch		4/15	4/15
T.X. Valve Refrigerant Control		(2) CBBIZE-5-GA	(2) CBBIZE-6-GA
Filter Size (std.)* No. Req'd		(4) 16 X 25 X 1	Field Installed
CABINET:			
Finish		Prepaint	Prepaint
Sheet Metal		Galvanized	Galvanized
Gauge: Top		18	18
Sides		16	16
Bottom		18	18
Door and Covers		20 min.	20 min.
UNIT WEIGHTS:			
Operating	R—Drive	330	447
	S—Drive	330	458
	T—Drive	341	458
Shipping	R—Drive	396	513
	S—Drive	396	535
	T—Drive	407	535

AIRFLOW PERFORMANCE RHCLP2090 — 7.5 TON [26.4kW] — 60 Hz — SIDEFLOW

Air Flow CFM [L/s]		External Static Pressure—Inches of Water [kPa]																																						
		0.1 [0.02]	0.2 [0.05]	0.3 [0.07]	0.4 [0.10]	0.5 [0.12]	0.6 [0.15]	0.7 [0.17]	0.8 [0.20]	0.9 [0.22]	1.0 [0.25]	1.1 [0.27]	1.2 [0.30]	1.3 [0.32]	1.4 [0.35]	1.5 [0.37]	1.6 [0.40]	1.7 [0.42]	1.8 [0.45]	1.9 [0.47]	2.0 [0.50]																			
		RPM	W	RPM	W	RPM	W	RPM	W	RPM	W	RPM	W	RPM	W	RPM	W	RPM	W	RPM	W	RPM	W																	
2400 [1133]	—	—	626	590	673	644	720	696	767	745	803	792	843	854	883	915	921	976	959	1036	995	1095	1004	1103	1035	1157	1066	1212	1096	1268	1126	1327	1156	1387	1185	1449	1214	1513	1237	1497
2500 [1180]	—	—	641	634	688	688	734	741	780	790	815	835	855	898	893	961	931	1023	968	1084	1004	1145	1013	1162	1044	1219	1075	1277	1105	1337	1135	1399	1164	1463	1193	1528	1222	1595	1246	1582
2600 [1227]	—	—	657	680	703	736	748	788	793	838	828	883	867	948	904	1012	941	1075	977	1138	1012	1200	1023	1226	1054	1286	1084	1347	1114	1411	1144	1476	1173	1542	1202	1611	1230	1681	1256	1672
2700 [1274]	628	671	673	730	718	786	763	839	806	890	840	936	878	1003	915	1068	951	1133	987	1197	1001	1233	1033	1294	1063	1357	1094	1422	1124	1489	1153	1557	1182	1627	1210	1699	1242	1717	1266	1767
2800 [1321]	645	724	690	783	734	839	778	893	815	926	853	995	890	1063	927	1130	962	1196	996	1261	1012	1302	1043	1367	1073	1433	1103	1501	1133	1571	1162	1643	1191	1716	1219	1791	1252	1814	1276	1867
2900 [1368]	663	779	707	839	750	896	793	951	829	989	866	1059	903	1128	938	1196	973	1264	1006	1331	1022	1376	1053	1444	1083	1514	1113	1585	1142	1658	1172	1733	1200	1810	1228	1888	1262	1914	1286	1970
3000 [1416]	682	838	725	898	767	956	806	985	843	1057	879	1128	915	1199	950	1269	983	1338	1016	1406	1032	1455	1063	1526	1093	1599	1123	1674	1152	1750	1181	1828	1209	1908	1248	1959	1272	2020	1296	2079
3100 [1463]	701	900	743	961	784	1019	820	1056	857	1130	893	1203	928	1275	961	1346	994	1416	1012	1466	1043	1539	1074	1613	1104	1689	1133	1767	1162	1847	1191	1928	1219	2011	1258	2066	1282	2130	1306	2192
3200 [1510]	720	965	761	1026	802	1085	836	1133	871	1208	906	1283	940	1356	973	1429	1005	1500	1023	1551	1054	1627	1084	1705	1114	1784	1143	1865	1172	1948	1201	2033	1229	2119	1268	2177	1293	2244	1316	2310
3300 [1557]	740	1033	780	1095	815	1139	851	1216	886	1292	920	1368	953	1442	985	1516	1017	1590	1035	1640	1065	1720	1095	1801	1125	1883	1154	1968	1182	2054	1211	2142	1254	2222	1279	2293	1303	2363	1326	2432
3400 [1604]	760	1104	799	1167	831	1225	866	1303	900	1381	934	1458	966	1534	998	1610	1015	1654	1046	1735	1076	1817	1106	1901	1135	1987	1164	2075	1193	2164	1221	2255	1265	2339	1290	2413	1314	2487	—	—
3500 [1652]	781	1179	812	1236	847	1316	882	1396	915	1475	948	1554	979	1631	1010	1708	1027	1749	1057	1833	1088	1919	1117	2006	1146	2096	1175	2187	1203	2279	1250	2382	1276	2461	1300	2538	1324	2615	—	—
4000 [1888]	868	1677	900	1766	931	1853	962	1940	991	2026	997	2006	1028	2101	1058	2198	1088	2296	1118	2397	1147	2489	1175	2602	1204	2708	1186	2803	1214	2939	1261	2905	1287	2587	1311	2668	—	—	—	—

Airflow CFM [L/s]	AIRFLOW CORRECTION FACTORS *			Wet Coil		MERV 8 Filter		MERV 13 Filter	
	Total MBH	Sensible MBH	Power kW	Resistance Inches of Water [kPa]	Resistance Inches of Water	Resistance Inches of Water	Resistance Inches of Water		
2400 [1133]	0.93	0.73	0.96	0.04 [0.01]	0.097	0.103	—	—	
2500 [1180]	0.93	0.74	0.96	0.05 [0.01]	0.106	0.112	—	—	
2600 [1227]	0.94	0.76	0.97	0.05 [0.01]	0.115	0.121	—	—	
2700 [1274]	0.94	0.78	0.97	0.05 [0.01]	0.124	0.130	—	—	
2800 [1321]	0.95	0.80	0.97	0.05 [0.01]	0.133	0.138	—	—	
2900 [1368]	0.95	0.81	0.97	0.06 [0.01]	0.142	0.147	—	—	
3000 [1416]	0.95	0.83	0.98	0.06 [0.01]	0.151	0.156	—	—	
3100 [1463]	0.96	0.85	0.98	0.06 [0.01]	0.160	0.164	—	—	
3200 [1510]	0.96	0.87	0.98	0.06 [0.01]	0.169	0.173	—	—	
3300 [1557]	0.97	0.88	0.99	0.07 [0.02]	0.178	0.182	—	—	
3400 [1604]	0.97	0.90	0.99	0.07 [0.02]	0.188	0.190	—	—	
3500 [1652]	0.98	0.92	0.99	0.07 [0.02]	0.197	0.199	—	—	
3600 [1699]	0.98	0.93	0.99	0.08 [0.02]	0.206	0.208	—	—	
3700 [1746]	0.99	0.95	1.00	0.08 [0.02]	0.215	0.217	—	—	
3800 [1793]	0.99	0.97	1.00	0.08 [0.02]	0.224	0.225	—	—	
3900 [1840]	1.00	0.99	1.00	0.08 [0.02]	0.233	0.234	—	—	
4000 [1888]	1.00	1.00	1.01	0.09 [0.02]	0.242	0.243	—	—	

* Multiply correction factor times gross performance data — resulting sensible capacity cannot exceed total capacity.

[] Designates Metric Conversions

PERFORMANCE DATA @ AHRI STANDARD CONDITIONS

MODEL NUMBERS		80°F [26.5°C] DB 67°F [19.5°C] WB INDOOR AIR 95°F [35°C] DB OUTDOOR AIR					RATED INDOOR CFM [L/s]
OUTDOOR UNIT RPCL-	INDOOR COIL AND/OR AIR HANDLER	TOTAL CAPACITY BTU/H [kW]	NET SENSIBLE BTU/H [kW]	NET LATENT BTU/H [kW]	EER	IEER	
RPCL2090	RHCLP2090	85000 [24.9]	58200 [17.1]	26800 [7.8]	11.0	12.2	2650
RPCL2120	RHCLP2120	113000 [33.1]	83100 [24.3]	29900 [8.8]	11.2	12.2	3400

[] Designates Metric Conversions

COOLING PERFORMANCE DATA – RPCL2090CAZ + RHCLP2090CA(-)

wBE		ENTERING INDOOR AIR @ 80°F [26.7°C] dbE ①														
		71°F [21.7°C]			67°F [19.4°C]			63°F [17.2°C]			61°F [16.1°C]			59°F [15.0°C]		
		3600 [1699]	3225 [1522]	2400 [1133]	3600 [1699]	3225 [1522]	2400 [1133]	3600 [1699]	3225 [1522]	2400 [1133]	3600 [1699]	3225 [1522]	2400 [1133]	3600 [1699]	3225 [1522]	2400 [1133]
CFM [L/s]	DR ①	0.21	0.19	0.12	0.21	0.19	0.12	0.21	0.19	0.12	0.21	0.19	0.12	0.21	0.12	
75 [23.9]	Total BTUH [kW]	104.3 [39.6]	102.2 [29.9]	97.4 [28.5]	97.0 [28.4]	95.0 [27.8]	90.5 [26.5]	86.3 [25.3]	84.5 [24.8]	80.6 [23.6]	79.4 [23.3]	74.1 [21.7]	71.1 [20.8]	69.7 [20.4]	66.4 [19.5]	
	Sens BTUH [kW]	66.6 [19.5]	63.1 [18.5]	55.6 [16.3]	73.7 [21.6]	69.9 [20.5]	61.5 [18.0]	59.8 [17.5]	68.0 [19.9]	63.4 [18.6]	66.8 [19.6]	55.8 [16.4]	59.3 [17.4]	56.2 [16.5]	49.5 [14.5]	
	Power	7.2	7.1	6.9	6.6	6.6	6.4	5.9	6.1	5.7	5.8	5.6	5.5	5.5	5.3	
80 [26.7]	Total BTUH [kW]	102.5 [30.0]	100.4 [29.4]	95.7 [28.0]	95.1 [27.9]	93.1 [27.3]	88.8 [26.0]	84.4 [24.7]	82.7 [24.2]	78.8 [23.1]	77.5 [22.7]	72.4 [21.2]	69.3 [20.3]	67.9 [19.9]	64.7 [19.0]	
	Sens BTUH [kW]	66.0 [19.3]	62.6 [18.3]	55.1 [16.2]	73.1 [21.4]	69.4 [20.3]	61.1 [17.9]	59.4 [17.4]	67.4 [19.8]	62.1 [18.2]	66.3 [19.4]	55.4 [16.2]	58.7 [17.2]	55.7 [16.3]	49.1 [14.4]	
	Power	7.4	7.3	7.2	6.9	6.8	6.6	6.4	6.3	6.2	6.3	6.0	5.8	5.7	5.6	
85 [29.4]	Total BTUH [kW]	100.3 [29.4]	98.2 [28.8]	93.7 [27.4]	92.9 [27.2]	91.0 [26.7]	86.8 [25.4]	82.3 [24.1]	80.6 [23.6]	76.8 [22.5]	75.3 [22.1]	70.4 [20.6]	67.1 [19.7]	65.7 [19.3]	62.7 [18.4]	
	Sens BTUH [kW]	65.2 [19.1]	61.8 [18.1]	54.4 [16.0]	72.3 [21.2]	68.6 [20.1]	60.4 [17.7]	58.7 [17.2]	66.7 [19.5]	62.1 [18.2]	65.5 [19.2]	54.7 [16.0]	57.9 [17.0]	54.9 [16.1]	48.4 [14.2]	
	Power	7.7	7.6	7.5	7.2	7.1	6.9	6.5	6.5	6.4	6.3	6.1	6.0	6.0	5.8	
90 [32.2]	Total BTUH [kW]	97.8 [28.7]	95.8 [28.1]	91.3 [26.8]	90.4 [26.5]	88.6 [26.0]	84.5 [24.7]	79.8 [23.4]	78.1 [22.9]	74.5 [21.8]	72.9 [21.3]	68.0 [19.9]	64.6 [18.9]	63.3 [18.5]	60.3 [17.7]	
	Sens BTUH [kW]	64.0 [18.8]	60.7 [17.8]	53.5 [15.7]	71.2 [20.9]	67.5 [19.8]	59.4 [17.4]	57.7 [16.9]	65.6 [19.2]	61.0 [17.9]	64.3 [18.9]	53.7 [15.7]	56.8 [16.6]	53.8 [15.8]	47.4 [13.9]	
	Power	8.0	8.0	7.8	7.5	7.4	7.3	7.3	6.9	6.9	6.7	6.4	6.4	6.3	6.2	
95 [35]	Total BTUH [kW]	95.0 [27.8]	93.0 [27.3]	88.7 [26.0]	87.6 [25.7]	85.8 [25.2]	81.8 [24.0]	77.0 [22.6]	75.4 [22.1]	71.9 [21.1]	70.1 [20.5]	65.4 [19.2]	61.8 [18.1]	60.5 [17.7]	57.7 [16.9]	
	Sens BTUH [kW]	62.6 [18.3]	59.4 [17.4]	52.3 [15.3]	69.7 [20.4]	66.1 [19.4]	58.2 [17.1]	56.5 [16.6]	64.2 [18.8]	59.7 [17.5]	62.9 [18.4]	52.5 [15.4]	55.3 [16.2]	52.5 [15.4]	46.2 [13.5]	
	Power	8.4	8.4	8.2	7.9	7.8	7.6	7.5	7.3	7.3	7.1	6.8	6.8	6.7	6.6	
100 [37.8]	Total BTUH [kW]	91.9 [26.9]	90.0 [26.4]	85.8 [25.1]	84.5 [24.8]	82.8 [24.3]	78.9 [23.1]	73.9 [21.6]	72.3 [21.2]	69.0 [20.2]	66.9 [19.6]	62.5 [18.3]	58.7 [17.2]	57.5 [16.8]	54.8 [16.1]	
	Sens BTUH [kW]	60.9 [17.8]	57.7 [16.9]	50.8 [14.9]	68.0 [19.9]	64.5 [18.9]	56.8 [16.6]	55.1 [16.1]	62.6 [18.3]	58.8 [19.3]	61.2 [17.9]	51.1 [15.0]	53.6 [15.7]	50.8 [14.9]	44.8 [13.1]	
	Power	8.9	8.8	8.6	8.3	8.2	8.0	8.0	7.8	7.7	7.5	7.2	7.2	7.1	7.0	
105 [40.6]	Total BTUH [kW]	88.5 [25.9]	86.6 [25.4]	82.6 [24.2]	81.1 [23.8]	79.4 [23.3]	75.7 [22.2]	70.4 [20.6]	69.0 [20.2]	65.8 [19.3]	63.5 [18.6]	59.3 [17.4]	55.3 [16.2]	54.1 [15.9]	51.6 [15.1]	
	Sens BTUH [kW]	58.8 [17.2]	55.8 [16.4]	49.1 [14.4]	65.9 [19.3]	62.6 [18.3]	55.1 [16.1]	53.4 [15.6]	60.6 [17.8]	56.8 [19.3]	59.1 [17.3]	49.4 [14.5]	51.5 [15.1]	48.9 [14.3]	43.1 [12.6]	
	Power	9.4	9.3	9.1	8.8	8.7	8.5	8.2	8.2	8.0	8.0	7.9	7.7	7.7	7.6	
110 [43.3]	Total BTUH [kW]	84.7 [24.8]	83.0 [24.3]	79.1 [23.2]	77.3 [22.7]	75.7 [22.2]	72.2 [21.2]	66.7 [19.5]	65.3 [19.1]	62.2 [18.2]	59.7 [17.5]	55.8 [16.3]	51.5 [15.1]	50.4 [14.8]	48.1 [14.1]	
	Sens BTUH [kW]	56.5 [16.6]	53.6 [15.7]	47.2 [13.8]	63.6 [18.6]	60.3 [17.7]	53.1 [15.6]	51.4 [15.1]	58.4 [17.1]	54.8 [15.8]	56.8 [16.6]	47.4 [13.9]	49.2 [14.4]	46.7 [13.7]	41.1 [12.0]	
	Power	9.9	9.8	9.6	9.3	9.2	9.0	8.8	8.7	8.7	8.5	8.4	8.2	8.1	8.0	
115 [46.1]	Total BTUH [kW]	80.6 [23.6]	79.0 [23.1]	75.3 [22.1]	73.3 [21.5]	71.7 [21.0]	68.4 [20.0]	62.6 [18.3]	61.3 [18.0]	58.4 [17.1]	55.7 [16.3]	52.0 [15.2]	47.4 [13.9]	46.5 [13.6]	44.3 [13.0]	
	Sens BTUH [kW]	53.9 [15.8]	51.1 [15]	45.0 [13.2]	61.0 [17.9]	57.8 [16.9]	50.9 [14.9]	49.2 [14.4]	55.9 [16.4]	51.4 [15.1]	54.1 [15.9]	45.2 [13.3]	46.6 [13.6]	44.2 [12.9]	38.9 [11.4]	
	Power	10.5	10.4	10.1	9.9	9.8	9.6	9.4	9.4	9.3	9.1	8.8	8.8	8.7	8.5	
120 [48.9]	Total BTUH [kW]	76.2 [22.3]	74.7 [21.9]	71.2 [20.9]	68.9 [20.2]	67.5 [19.8]	64.3 [18.8]	58.2 [17.1]	57.0 [16.7]	54.4 [15.9]	51.3 [15.0]	47.9 [14.0]	43.1 [12.6]	42.2 [12.4]	40.2 [11.8]	
	Sens BTUH [kW]	50.9 [14.9]	48.3 [14.2]	42.5 [12.5]	58.0 [17.0]	55.0 [16.1]	48.5 [14.2]	46.8 [13.7]	53.1 [15.6]	48.6 [14.2]	51.2 [15.0]	42.8 [12.5]	43.1 [12.6]	41.4 [12.1]	36.4 [10.7]	
	Power	11.1	11.0	10.7	10.5	10.4	10.2	10.2	10	9.9	9.7	9.6	9.4	9.3	9.1	
125 [51.7]	Total BTUH [kW]	71.5 [21]	70.1 [20.5]	66.8 [19.6]	64.2 [18.8]	62.8 [18.4]	59.9 [17.6]	53.5 [15.7]	52.4 [15.4]	50.0 [14.6]	46.6 [13.7]	43.5 [12.7]	38.4 [11.2]	37.6 [11]	35.8 [10.5]	
	Sens BTUH [kW]	47.7 [14]	45.2 [13.3]	39.8 [11.7]	54.8 [16.1]	52.0 [15.2]	45.8 [13.4]	44.1 [12.9]	50.1 [14.7]	44.1 [12.9]	46.6 [13.7]	40.1 [11.7]	38.4 [11.2]	37.6 [11]	33.7 [9.9]	
	Power	11.8	11.7	11.4	11.2	11.1	10.9	10.7	10.6	10.6	10.3	10.3	10.1	10.1	10.0	

DR — Depression ratio
dbE — Entering air dry bulb
wBE — Entering air wet bulb

NOTES:
① When the entering air dry bulb is other than 80°F [27°C], adjust the sensible capacity from the table by adding [1.10 x CFM x (1 – DR) x (dbE – 80)].

Legend

Total — Total capacity x 1000 BTUH
Sens — Sensible capacity x 1000 BTUH
Power — KW Input

Legend

Total — Total capacity x 1000 BTUH
Sens — Sensible capacity x 1000 BTUH
Power — KW Input

COOLING PERFORMANCE DATA — RPCL2120CAZ+RHCLP2120CA(-)

wDE		ENTERING INDOOR AIR @ 80°F [26.7°C] dbE ①											
		71°F [21.7°C]		67°F [19.4°C]		63°F [17.2°C]		61°F [16.1°C]		59°F [15.0°C]			
CFM [L/s]		4500 [2124]	3400 [1605]	3000 [1416]	4500 [2124]	3400 [1605]	3000 [1416]	4500 [2124]	3400 [1605]	3000 [1416]	4500 [2124]	3400 [1605]	3000 [1416]
DR ①		0.07	0.02	-0.01	0.07	0.02	-0.01	0.07	0.02	-0.01	0.07	0.02	-0.01
75°F [23.9°C]	Total BTUH [kW]	144.4 [42.3]	136.4 [40.0]	133.5 [39.1]	135.1 [39.6]	127.5 [37.4]	124.8 [36.6]	126.1 [37.0]	119.1 [34.9]	116.6 [34.2]	118.1 [34.6]	111.5 [32.7]	109.1 [32.0]
	Sens BTUH [kW]	90.0 [26.4]	78.2 [22.9]	73.9 [21.7]	106.3 [31.2]	92.4 [27.1]	87.3 [25.6]	117.5 [34.4]	102.1 [29.9]	96.5 [28.3]	118.1 [34.6]	105.0 [30.8]	99.3 [29.1]
	Power	8.0	7.7	7.7	7.9	7.6	7.6	7.7	7.5	7.5	7.4	7.6	7.4
80°F [26.7°C]	Total BTUH [kW]	141.8 [41.5]	133.9 [39.2]	131.0 [38.4]	132.4 [38.8]	125.1 [36.6]	122.4 [35.9]	123.5 [36.2]	116.6 [34.2]	114.1 [33.4]	115.4 [33.8]	109.0 [31.9]	106.7 [31.3]
	Sens BTUH [kW]	88.9 [26.1]	77.3 [22.6]	73.0 [21.4]	105.2 [30.8]	91.4 [26.8]	86.4 [25.3]	116.4 [34.1]	101.1 [29.6]	95.6 [28.0]	115.4 [33.8]	104.1 [30.5]	98.4 [28.8]
	Power	8.3	8.1	8.0	8.2	8.0	7.9	8.1	7.9	7.8	8.0	7.8	7.7
85°F [29.4°C]	Total BTUH [kW]	139.0 [40.7]	131.3 [38.5]	128.5 [37.6]	129.6 [38.0]	122.4 [35.9]	119.8 [35.1]	120.7 [35.4]	114.0 [33.4]	111.6 [32.7]	112.7 [33.0]	106.4 [31.2]	104.1 [30.5]
	Sens BTUH [kW]	87.7 [25.7]	76.2 [22.3]	72.0 [21.1]	104.0 [30.5]	90.4 [26.5]	85.4 [25.0]	115.2 [33.8]	100.1 [29.3]	94.6 [27.7]	112.7 [33.0]	103.0 [30.2]	97.4 [28.5]
	Power	8.7	8.4	8.4	8.6	8.3	8.3	8.5	8.2	8.1	8.4	8.1	8.0
90 [32.2°C]	Total BTUH [kW]	136.1 [39.9]	128.5 [37.7]	125.8 [36.9]	126.7 [37.1]	119.7 [35.1]	117.1 [34.3]	117.8 [34.5]	111.3 [32.6]	108.9 [31.9]	109.8 [32.2]	103.7 [30.4]	101.4 [29.7]
	Sens BTUH [kW]	86.4 [25.3]	75.1 [22.0]	70.9 [20.8]	102.7 [30.1]	89.2 [26.1]	84.3 [24.7]	113.8 [33.3]	98.9 [29.0]	93.5 [27.4]	109.8 [32.2]	101.9 [29.9]	96.3 [28.2]
	Power	9.1	8.8	8.7	9.0	8.7	8.6	8.9	8.6	8.5	8.8	8.5	8.4
95°F [35°C]	Total BTUH [kW]	133.1 [39.0]	125.7 [36.8]	123.0 [36.0]	123.7 [36.2]	116.8 [34.2]	114.3 [33.5]	114.8 [33.6]	108.4 [31.8]	106.1 [31.1]	106.7 [31.3]	100.8 [29.5]	98.6 [28.9]
	Sens BTUH [kW]	84.9 [24.9]	73.8 [21.6]	69.7 [20.4]	101.2 [29.7]	87.9 [25.8]	83.1 [24.4]	112.4 [32.9]	97.6 [28.6]	92.3 [27.0]	106.7 [31.3]	100.6 [29.5]	95.1 [27.9]
	Power	9.5	9.3	9.2	9.4	9.2	9.1	9.3	9.0	9.0	9.2	8.9	8.8
100°F [37.8°C]	Total BTUH [kW]	129.9 [38.1]	122.7 [35.9]	120.1 [35.2]	120.5 [35.3]	113.8 [33.4]	111.4 [32.6]	111.6 [32.7]	105.4 [30.9]	103.1 [30.2]	103.6 [30.3]	97.8 [28.7]	95.7 [28.0]
	Sens BTUH [kW]	83.3 [24.4]	72.3 [21.2]	68.4 [20.0]	99.6 [29.2]	86.5 [25.3]	81.8 [24.0]	110.7 [32.4]	96.2 [28.2]	90.9 [26.6]	103.6 [30.3]	97.8 [28.7]	93.7 [27.5]
	Power	10.0	9.7	9.6	9.9	9.6	9.5	9.8	9.5	9.4	9.7	9.4	9.3
105°F [40.6°C]	Total BTUH [kW]	126.6 [37.1]	119.6 [35.0]	117.0 [34.3]	117.2 [34.4]	110.7 [32.4]	108.3 [31.7]	108.3 [31.7]	102.3 [30.0]	100.1 [29.3]	100.3 [29.4]	94.7 [27.7]	92.7 [27.2]
	Sens BTUH [kW]	81.5 [23.9]	70.8 [20.7]	66.9 [19.6]	97.8 [28.7]	85.0 [24.9]	80.3 [23.5]	108.3 [31.7]	94.7 [27.7]	89.5 [26.2]	100.3 [29.4]	94.7 [27.7]	92.3 [27.0]
	Power	10.5	10.2	10.1	10.4	10.1	10.0	10.3	10.0	9.9	10.2	9.9	9.8
110°F [43.3°C]	Total BTUH [kW]	123.2 [36.1]	116.3 [34.1]	113.8 [33.4]	113.8 [33.3]	107.5 [31.5]	105.2 [30.8]	104.9 [30.7]	99.0 [29.0]	96.9 [28.4]	96.8 [28.4]	91.4 [26.8]	89.5 [26.2]
	Sens BTUH [kW]	79.6 [23.3]	69.1 [20.3]	65.3 [19.1]	95.9 [28.1]	83.3 [24.4]	78.7 [23.1]	104.9 [30.7]	93.0 [27.3]	87.9 [25.8]	96.8 [28.4]	91.4 [26.8]	89.5 [26.2]
	Power	11.0	10.7	10.6	10.9	10.6	10.5	10.8	10.5	10.4	10.7	10.4	10.3
115°F [46.1°C]	Total BTUH [kW]	119.6 [35.0]	112.9 [33.1]	110.5 [32.4]	110.2 [32.3]	104.1 [30.5]	101.9 [29.9]	101.3 [29.7]	95.7 [28.0]	93.6 [27.4]	93.2 [27.3]	88.1 [25.8]	86.2 [25.3]
	Sens BTUH [kW]	77.5 [22.7]	67.4 [19.7]	63.7 [18.7]	93.8 [27.5]	81.5 [23.9]	77.0 [22.6]	101.3 [29.7]	91.2 [26.7]	86.2 [25.3]	93.2 [27.3]	88.1 [25.8]	86.2 [25.3]
	Power	11.6	11.2	11.1	11.4	11.1	11.0	11.3	11.0	10.9	11.2	10.9	10.8
120°F [48.9°C]	Total BTUH [kW]	115.9 [34.0]	109.4 [32.1]	107.1 [31.4]	106.5 [31.2]	100.6 [29.5]	98.4 [28.8]	97.6 [28.6]	92.2 [27.0]	90.2 [26.4]	89.5 [26.2]	84.6 [24.8]	82.8 [24.3]
	Sens BTUH [kW]	75.3 [22.1]	65.4 [19.2]	61.9 [18.1]	91.6 [26.9]	79.6 [23.3]	75.2 [22.0]	97.6 [28.6]	89.3 [26.2]	84.4 [24.7]	89.5 [26.2]	84.6 [24.8]	82.8 [24.3]
	Power	12.1	11.8	11.7	12.0	11.7	11.6	11.9	11.6	11.5	11.8	11.5	11.4
125°F [51.7°C]	Total BTUH [kW]	112.1 [32.8]	105.8 [31.0]	103.6 [30.3]	102.7 [30.1]	97.0 [28.4]	94.9 [27.8]	93.8 [27.5]	88.6 [25.9]	86.7 [25.4]	85.7 [25.1]	81.0 [23.7]	79.2 [23.2]
	Sens BTUH [kW]	73.0 [21.4]	63.4 [18.6]	59.9 [17.6]	89.3 [26.2]	77.6 [22.7]	73.3 [21.5]	93.8 [27.5]	87.3 [25.6]	82.5 [24.2]	85.7 [25.1]	81.0 [23.7]	79.2 [23.2]
	Power	12.7	12.4	12.3	12.6	12.3	12.2	12.5	12.2	12.0	12.4	12.1	11.9

DR —Depression ratio
dbE —Entering air dry bulb
wDE—Entering air wet bulb

NOTES:
① When the entering air dry bulb is other than 80°F [27°C], adjust the sensible capacity from the table by adding [1.10 x CFM x (1 – DR) x (dbE – 80)].

[] Designates Metric Conversions

Total —Total capacity x 1000 BTUH
Sens —Sensible capacity x 1000 BTUH
Power —KW input

ELECTRICAL DATA—WITHOUT ELECTRIC HEAT

MODEL NUMBER	DRIVE PACKAGE	AIR HANDLER MOTOR					MINIMUM CIRCUIT AMPACITY	RECOMMENDED MINIMUM COPPER WIRE SIZE/ MAX. RUN IN FEET	MAXIMUM OVERCURRENT PROTECTION AMPS
		HP	VOLTS	PHASE	RATING PLATE AMPS	MOTOR LRA			
RHCLP2090C	R, S	2	208/230	3	6.2	47	15	#14 / 165	15
RHCLP2090D	R, S	2	460	3	3	24	15	#14 / 275	15
RHCLP2090C	T	3	208/230	3	9.2	74.5	15	#14 / 135	15
RHCLP2090D	T	3	460	3	4.6	38.1	15	#14 / 230	15
RHCLP2120C	R	2	208/230	3	6.2	47	15	#14 / 165	15
RHCLP2120D	R	2	460	3	3	24	15	#14 / 275	15
RHCLP2120C	S, T	3	208/230	3	9.2	74.5	15	#14 / 135	15
RHCLP2120D	S, T	3	460	3	4.6	38.1	15	#14 / 230	15

ELECTRICAL DATA—WITH ELECTRIC HEAT

MODEL NUMBER	HEATER KIT				HEATING CAPACITY		MIN. CIRCUIT AMPACITY	MAX FUSE OR HACR BREAKER SIZE
	MODEL	VOLTAGE	kW	AMPS	kW	MBH		
RHCLP2090C	RXHE-DE020CA	208/240	20	43.1/48.9	15.6/20.2	53.2/68.9	67/73	70/80
RHCLP2090C	RXHE-DE030CA	208/240	30	60.8/70.2	11.0/29.6	75.1/101	89/100	90/100
RHCLP2090D	RXHE-DE020DA	480	20	24.7	20.2	68.9	37	40
RHCLP2090D	RXHE-DE030DA	480	30	35	29.7	101.3	50	50
RHCLP2120C	RXHE-DE020CA	208/240	20	43.1/48.9	15.6/20.2	53.2/68.9	67/73	70/80
RHCLP2120C	RXHE-DE030CA	208/240	30	60.8/70.2	11.0/29.6	75.1/101	89/100	90/100
RHCLP2120D	RXHE-DE020DA	480	20	24.7	20.2	68.9	37	40
RHCLP2120D	RXHE-DE030DA	480	30	35	29.7	101.3	50	50

TYPICAL PIPING RECOMMENDATIONS

INDOOR COIL ABOVE OUTDOOR UNIT

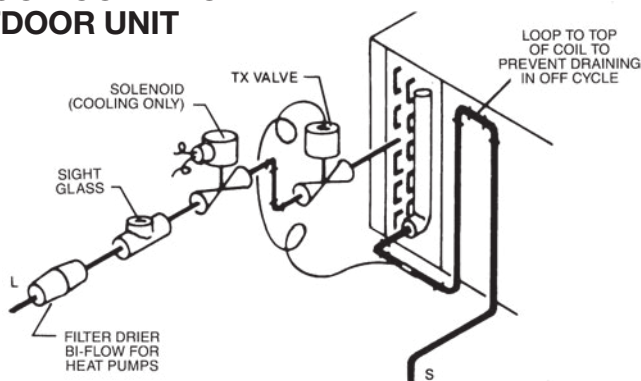

INDOOR COIL BELOW OUTDOOR UNIT

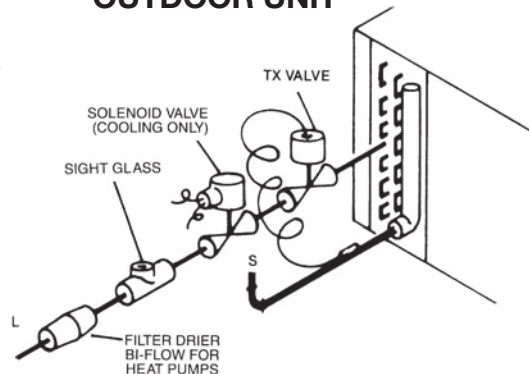

NOTE: PIPING ACCESSORIES SHOWN SHOULD BE MOUNTED AS CLOSE TO AIR HANDLING UNIT AS POSSIBLE.

REFRIGERANT PIPING

1. Size liquid line for no more than 50 PSIG pressure drop.
2. Size suction lines for no more than 2°F loss, which corresponds to approximately 5 PSIG pressure drop.
3. When evaporator is installed below condensing unit, do not exceed the recommended suction line O.D. This will insure adequate velocities for proper oil return.
4. Install strainer-drier and sight glass in liquid line.
5. Pitch all horizontal suction lines downward in the direction of flow.
6. When making up refrigerant piping, take every precaution to prevent dirt and moisture from entering the piping.
7. Locate the condensing unit and evaporator(s) as close together as possible to minimize piping runs.
8. A liquid line solenoid installed just ahead of the expansion valve is recommended.
9. See tables below for general refrigerant line sizing and equivalent length of valves and fittings.
10. Refer to the vapor and liquid line selection procedure and charts in the outdoor unit installation manual or literature for more specific refrigerant line sizing information. When dual outdoor units are matched with the air-handler using dual circuits, size the refrigerant lines for each system independently.

RECOMMENDED VAPOR AND LIQUID LINE SIZES FOR VARIOUS LENGTHS OF RUN				
LINEAR LENGTH (FT.) [m]	LIQUID LINE O.D. SIZES (IN.) [mm]		VAPOR LINE O.D. SIZES (IN.) [mm]	
	090	120	090	120
0-40 [0-12.19]	1/2 [12.7]	5/8 [15.88]	1 1/8 [28.58]	1 3/8 [34.93]
41-90 [12.5-27.43]	1/2 [12.7]	5/8 [15.88]	1 3/8 [34.93]*	1 3/8 [34.93]*

*NOTE: With the outdoor unit located below the indoor air handler, all vertical vapor lines must not exceed 1 1/8" [28.58 mm] O.D.

[] Designates Metric Conversions

CONDENSATE DRAIN PIPING

- Consult local codes or ordinances for specific requirements regarding condensate drain.
- Condensate drain is open to atmosphere and must be trapped. Trap must be at least 3 inches [76 mm] deep and made of flexible material or fabricated to prevent freeze-up.
- Pitch the drain line at least 1/4 inch [6 mm] per foot away from the drain pan.
- Do not reduce the drain line size from the connection size provided on the unit.
- Do not connect the drain line to a closed sewer line.

TYPICAL PIPING RECOMMENDATIONS

All models are provided with dual circuit coil manifolds that can be configured for dual condensing unit applications. The coil is circuited to provide full face coil operation for each system. Knock-outs are provided on both sides of the unit to allow the refrigerant tubing to enter from either side. Remove the rubber grommets from the parts bag and install them in the appropriate holes prior to running the line set tubing into the cabinet to seal around and protect the tubing. Copper fittings are provided in the parts bag to allow the two refrigerant circuits to be tied together for single condensing unit applications. The fittings may be installed to allow the tubing to enter the unit from either side as shown in Figure 5.

EQUIVALENT LENGTH (FT.) [m] OF STRAIGHT TYPE "L" TUBING FOR NON-FERROUS VALVES AND FITTINGS (BRAZED)				
TUBE SIZE INCHES [mm] O.D.	ANGLE VALVE	SHORT RADIUS ELL	LONG RADIUS ELL	TEE LINE FLOW
1/2 [12.7]	24 [7.32]	4.7 [1.43]	3.2 [0.98]	1.7 [0.52]
5/8 [15.88]	25 [7.62]	5.7 [1.74]	3.9 [1.19]	2.3 [0.70]
3/4 [19.05]	25 [7.62]	6.5 [1.98]	4.5 [1.37]	2.9 [0.88]
7/8 [22.23]	28 [8.53]	7.8 [2.38]	5.3 [1.62]	3.7 [1.13]
1 1/8 [28.58]	29 [8.84]	2.7 [0.82]	1.9 [0.58]	5.2 [1.59]
1 3/8 [34.93]	33 [10.06]	3.2 [0.98]	2.2 [0.67]	6.9 [2.10]

FIELD INSTALLED ACCESSORIES & KITS

ACCESSORY DESCRIPTION	MODEL NUMBER	SIZE USED ON	NET WEIGHT (LBS) [kg]
Hot Water Coil	RXHC-C74W	090, 120	200 [91]
Steam Coil	RXHC-C714S	090, 120	200 [91]
Filter Frame Coil	RXHF-B74A	090, 120	90 [41]
Inlet Grille Kit	RXHG-C74A	090, 120	9 [4]
Discharge Grille Kit	RXHG-C74B	090, 120	15 [7]
Discharge Plenum Kit	RXHL-C74B	090, 120	38 [17]
Mixing Box	RXHM-BC74H	090, 120	120 [54]
Auxiliary Heater Kit	RXHE-DE020*A	090, 120	75 [34]
	RXHE-DE030*A	090, 120	75 [34]
MERV 8	RXMF-M08A11625	090, 120	2 [1]
MERV 13	RXMF-M13A11625	090, 120	2 [1]
External Filter Rack	RXHF-F1	090, 120	18 [8]

NOTE: *Designates "C", "D" or "Y" Voltage

RXHM MIXING BOX



RXHE ELECTRIC HEATER KIT

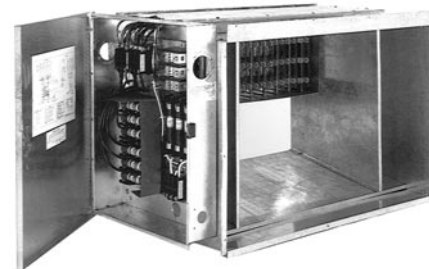

HOT WATER OR STEAM COILS

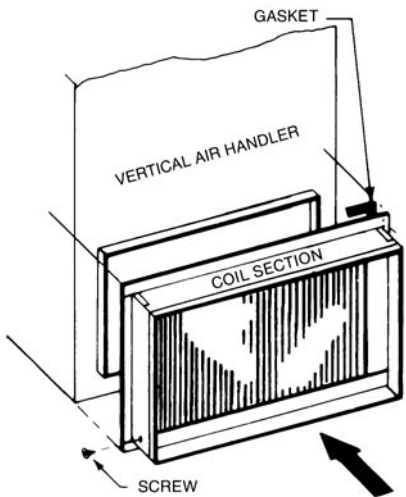

(090, 120) RXHC-C74W
RXHC-C74S

(090, 120) RXHC-C74W
RXHC-C74S

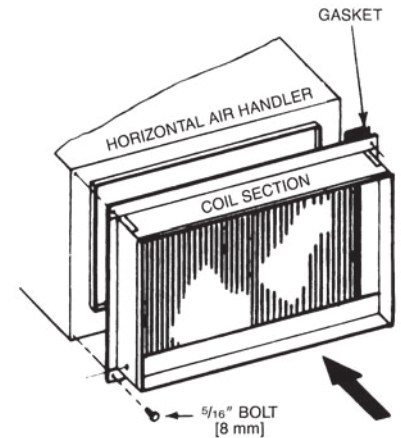

ELECTRIC RESISTANCE HEATER KITS

Optional electrical heater kit shown installed in horizontal position and connected directly to the air handler. The heater kit may also be installed with the air handler set in the vertical position. In either position the heater kit control compartment must be on the left side facing the air discharge opening.

AUXILIARY HEATER KIT

MODEL NO.	IN. [mm]	
	A	B
RXHE-DE****A	20 [508]	20 [508]

[] Designates Metric Conversions

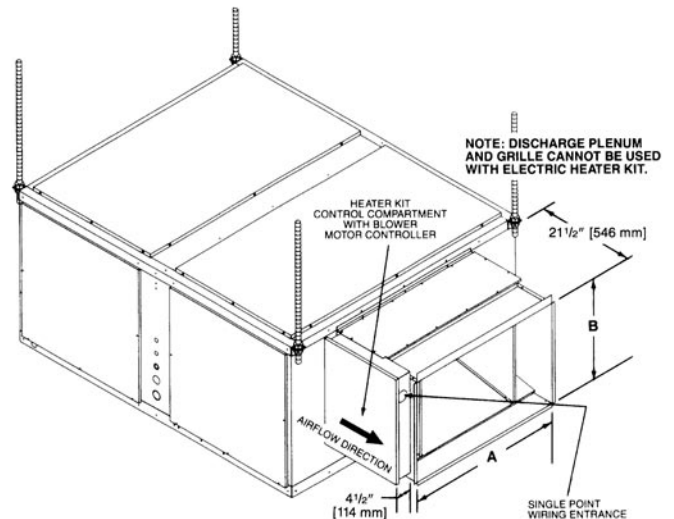

FIELD INSTALLED ACCESSORIES (Cont.)

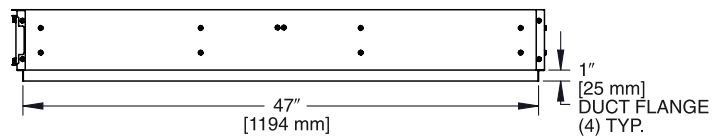
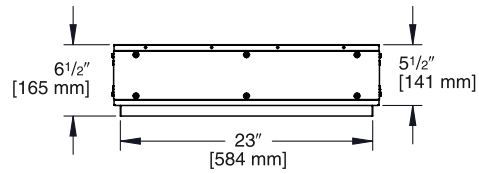
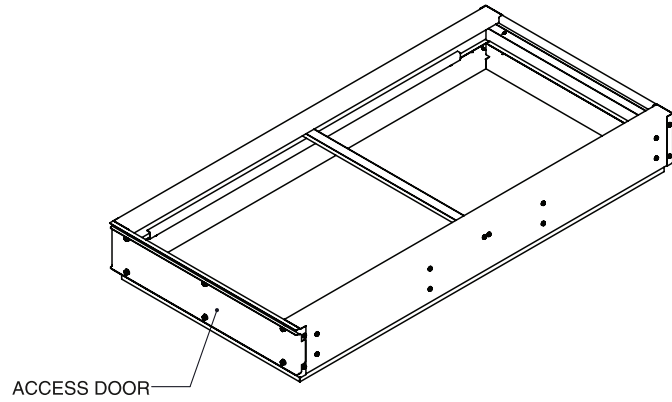
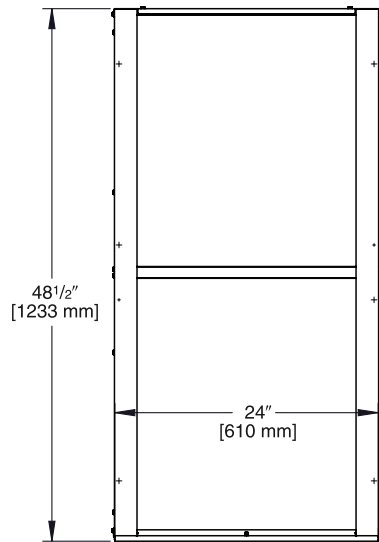

Illustration
ST-A1323-01

[] Designates Metric Conversions

GUIDE SPECIFICATIONS

Furnish and install as shown on the drawing for both horizontal and vertical applications. The entire assembly shall be UL and cUL listed with the cooling (and heat pump heating) capacity A.R.I. Certified.

DRIVE PACKAGE—A complete drive package shall be factory or field installed. Package shall consist of a 3450 RPM dual volt-age, single phase open drip proof motor or a 3 phase 1750 RPM open drip proof internally protected motor, not requiring an external starter. Variable pitch motor sheave, fixed pitch fan sheave, and belt.

COILS—Coils shall be fabricated of 3/8 " [10 mm] O.D. seamless copper tubing expanded into aluminum fins. All coils shall be submitted to an air pressure test of up to 550 PSIG [2068 kPa] under water after fabrication and dehydrated prior to assembly in unit. Units shall be shipped with a nitrogen holding charge. Airflow shall be draw through design providing uniform air distribution across the coil surface.

BLOWER, BEARINGS AND SHAFT—Fans shall be a double width, double inlet, forward curve, centrifugal type, statically and dynamically balanced, and constructed of galvanized steel. They shall be mounted on 3/4" [19 mm] = 7.5 ton [26 kW] diameter solid shafts made of high carbon steel, centerless ground and polished, supported by resilient mounted sealed bearings.

DRAIN PAN—The drain pan shall be manufactured of zinc coated steel. The pan shall have internally threaded pipe size drain connections and shall be designed to accept condensate in either horizontal or vertical type applications on either side of unit.

FILTERS—Filter mounting hardware shall be designed to accept up to 2" [51 mm] filters for field replacement. One inch [25 mm] throw away filters shall be furnished with the unit. MERV 8 and MERV 13 filters are available as an accessory.

CABINET—Cabinets shall be manufactured of galvanized steel subjected to multi-stage cleaning and finished with powder coat paint. Units shall have removable service access panels on each side and top.

INSULATION—Cabinets shall be insulated with 1/2" [13 mm] by 1-1/2 pound [.68 kg] density fiberglass insulation coated with neo-prene and bonded to the cabinet surface with a U.L. approved adhesive. Insulation shall have fire retarding characteristics in accordance with smoke developed rating not to exceed 50 and flame spread rating of 25 per Underwriters Laboratories testing procedures.

FACTORY TESTING—In addition to the pre-assembly testing mentioned above, each coil shall be leak tested after assembly into the unit. While under pressure, the coil shall be leak tested using an Electronic Leak Detector.

ELECTRIC HEATERS—UL and cUL listed electric heater kits shall be available in a wide range of capacities. All kits shall offer two stages of capacity, blower motor controller and single point connection. Heater kits shall be available for installation directly on the supply fan discharge for either horizontal or vertical application.

[] Designates Metric Conversions

GENERAL TERMS OF LIMITED WARRANTY*

Friedrich® will furnish a replacement for any part of this product which fails in normal use and services within the applicable periods stated below, in accordance with the terms of the limited warranty.

*For Complete Details of the Limited Warranty, Including Applicable Terms and Conditions, See Your Local Installer or Contact the Manufacturer for a Copy.

Any PartOne (1) Year



FRIEDRICH

1 8 8 3

Before proceeding with installation, refer to installation instructions packaged with each model, as well as complying with all Federal, State, Provincial, and Local codes, regulations, and practices.

© 2023 Rheem Manufacturing Company. Friedrich trademarks owned by Rheem Manufacturing Company.

In keeping with its policy of continuous progress and product improvement, Friedrich reserves the right to make changes without notice.

Friedrich • 5600 Old Greenwood Road
Fort Smith, Arkansas 72908 • www.friedrich.com

Friedrich • 125 Edgeware Road, Unit 1
Brampton, Ontario • L6Y 0P5