



# FRIEDRICH

1 8 8 3

PROJECT NAME \_\_\_\_\_  
LOCATION \_\_\_\_\_  
ARCHITECT \_\_\_\_\_  
ENGINEER \_\_\_\_\_  
CONTRACTOR \_\_\_\_\_  
SUBMITTED BY \_\_\_\_\_ DATE \_\_\_\_\_

## UNIT SUMMARY

Quantity						
Unit Designation						
Model No.						
Total Cooling						
Sensible Cooling						
Air Ent. Evaporator						
Air Lvg. Evaporator						
Heating Input						
Heating Output						
CFM/ESP						
EER/SEER						
Electrical						
Minimum Ampacity						
Min.-Max. Breaker						
Net Unit Weight						
Accessory						
Catalog Form Number						

**ACCESSORIES:**

**NOTES:**

# Endeavor® Line (-)A13NZ iC Air Conditioner

## Cooling Efficiencies up to: 15.2 SEER2/12 EER2

### Nominal Sizes: 1.5 to 5 Ton [5.0 to 16.3 kW]

JOB NAME \_\_\_\_\_ LOCATION \_\_\_\_\_

CONTRACTOR \_\_\_\_\_ ORDER NO. \_\_\_\_\_

ENGINEER \_\_\_\_\_ UNIT MODEL NO. \_\_\_\_\_

SUBMITTED FOR  APPROVAL  RECORD COIL MODEL NO. \_\_\_\_\_

DATE \_\_\_\_\_ AIR HANDLER MODEL NO. \_\_\_\_\_

#### UNIT DATA

##### COOLING PERFORMANCE

EFFICIENCY ..... SEER

TOTAL CAPACITY\* ..... MBH [kW]

SENSIBLE CAPACITY\* ..... MBH [kW]

OUTDOOR DESIGN TEMP..... °F [°C] DB

TEMP. OF AIR ENTERING  
EVAPORATOR COIL ..... °F [°C] DB

..... °F [°C] WB

POWER INPUT REQUIREMENT ..... kW  
(\*uses blower motor heat)

##### HEATING PERFORMANCE

EFFICIENCY ..... HSPF

TOTAL CAPACITY\* ..... MBH [kW]

OUTDOOR DESIGN TEMP..... °F [°C] DB

TEMP. OF AIR ENTERING  
EVAPORATOR COIL ..... °F [°C] DB

##### SUPPLY AIR BLOWER PERFORMANCE

TOTAL AIR SUPPLY ..... CFM [L/s]

TOTAL RESISTANCE EXTERNAL  
TO UNIT ..... IWG

BLOWER SPEED ..... RPM

POWER OUTPUT REQUIREMENT ..... BHP

MOTOR RATING ..... HP [W]

POWER INPUT REQUIREMENT ..... kW

##### ELECTRICAL DATA

POWER SUPPLY ..... Hz

TOTAL UNIT AMPACITY ..... AMPS

MINIMUM WIRE SIZE ..... AWG

MAXIMUM OVERCURRENT DEVICE  
FUSES/HACR BREAKER ..... AMPS

##### CLEARANCES

ACCESS SIDE 24" [609.6 mm]

AIR INLETS 12" [304.8 mm]

ABOVE UNIT 60" [1524 mm]

#### FEATURES

- **Fully Louvered Steel Cabinet:** Features durable construction to add protection from yard hazards, weather corrosion
- **Optimized 7 mm Coil<sup>1</sup>:** Design allows for improved airflow, heat transfer and energy consumption
- **Easily Accessible Control Box:** Ease of installation and serviceability

#### ACCESSORIES/OPTIONS

- Compressor Crankcase Heater .....
- Compressor Sound Cover .....
- Compressor Hard Start Kit .....
- Compressor Time Delay .....
- Low Pressure Control .....
- High Pressure Control .....
- Liquid Line Solenoid (24 VAC, 50/60 Hz) .....
- Liquid Line Solenoid (120/240 VAC, 50/60 Hz) .....
- Top Cap w/Label (91-101123-21) .....

<sup>1</sup> Does not apply to 5 ton models

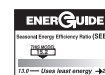

**(-)A13NZ**

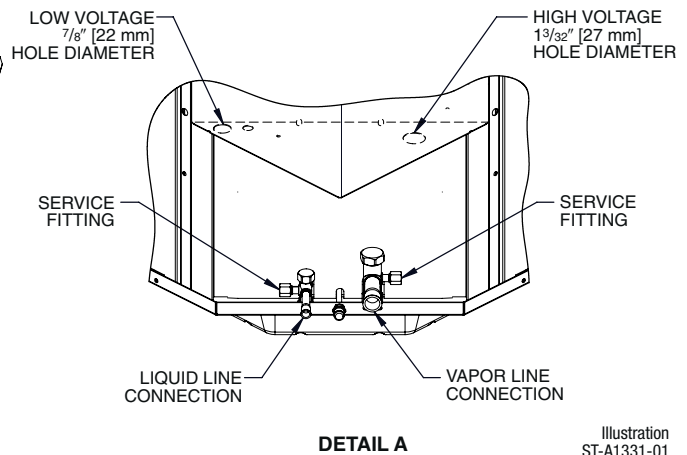
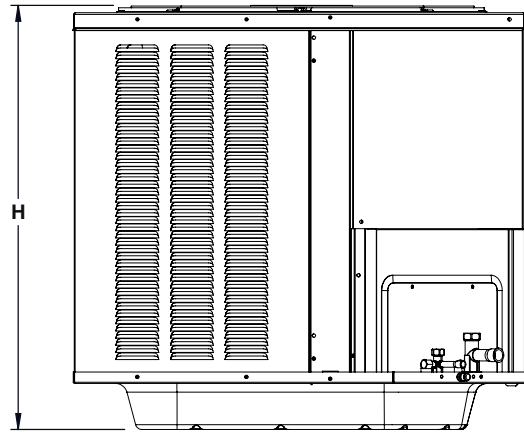
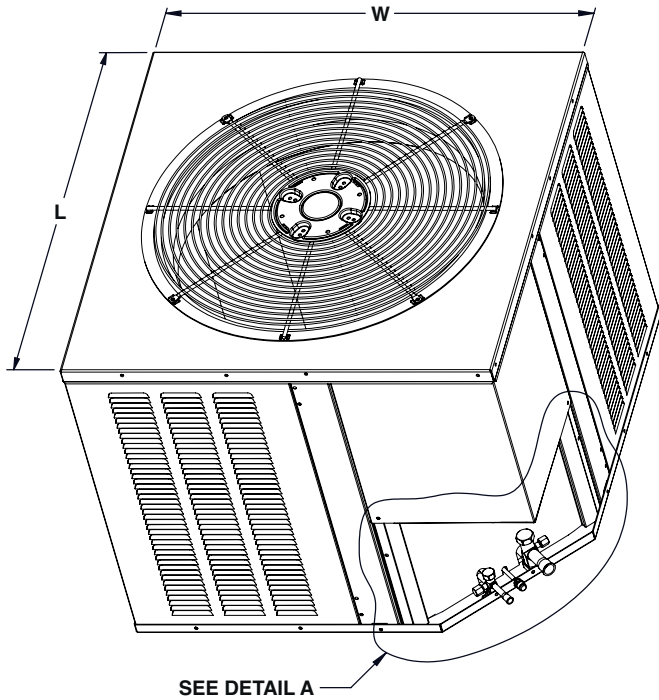

Illustration  
ST-A1331-01

[ ] Designates Metric Conversions

## Unit Dimensions

Model No.	Operating						Shipping					
	H (Height)		L (Length)		W (Width)		H (Height)		L (Length)		W (Width)	
	Inches	mm	Inches	mm	Inches	mm	Inches	mm	Inches	mm	Inches	mm
(-)A13NZ18AJ1	25.17	639	29.543	750	29.543	750	27.0625	687	32.625	829	32.625	829
(-)A13NZ24AJ1	25.17	639	33.655	855	33.655	855	27.0625	687	36.625	930	36.625	930
(-)A13NZ30AJ1	25.17	639	33.655	855	33.655	855	27.0625	687	36.625	930	36.625	930
(-)A13NZ36AJ1	25.17	639	33.655	855	33.655	855	27.0625	687	36.625	930	36.625	930
(-)A13NZ42AJ1	27.17	690	33.655	855	33.655	855	29.0625	738	36.625	930	36.625	930
(-)A13NZ48AJ1	39.17	995	35.543	903	35.543	903	41.0625	1043	38.625	981	38.625	981
(-)A13NZ60AJ1	45.17	1147	35.543	903	35.543	903	47.0625	1195	38.625	981	38.625	981

Before proceeding with installation, refer to installation instructions packaged with each model, as well as complying with all Federal, State, Provincial, and Local codes, regulations, and practices.

Rheem Sales Company, Inc.  
5600 Old Greenwood Road  
Fort Smith, Arkansas 72908

© 2023 Rheem Manufacturing Company. Rheem and Ruud trademarks owned by Rheem Manufacturing Company.

"In keeping with its policy of continuous progress and product improvement, Rheem reserves the right to make changes without notice."