



FRIEDRICH

1 8 8 3

PROJECT NAME _____
LOCATION _____
ARCHITECT _____
ENGINEER _____
CONTRACTOR _____
SUBMITTED BY _____ DATE _____

UNIT SUMMARY

Quantity						
Unit Designation						
Model No.						
Total Cooling						
Sensible Cooling						
Air Ent. Evaporator						
Air Lvg. Evaporator						
Heating Input						
Heating Output						
CFM/ESP						
EER/SEER						
Electrical						
Minimum Ampacity						
Min.-Max. Breaker						
Net Unit Weight						
Accessory						
Catalog Form Number						

ACCESSORIES:

NOTES:

Endeavor® Line (-)801T Downflow Gas Furnaces

Heating Stages: Single Stage

Motor Type: Constant Torque

Input Rates: 50-125 kBTU [14.6-36.6 kW]

JOB NAME _____ LOCATION _____

CONTRACTOR _____ ORDER NO. _____

ENGINEER _____ UNIT MODEL NO. _____

SUBMITTED FOR APPROVAL RECORD COIL MODEL NO. _____

DATE _____ AIR HANDLER MODEL NO. _____

UNIT DATA

HEATING PERFORMANCE

TOTAL CAPACITY INPUT* _____ MBH [kW]
 TOTAL CAPACITY OUTPUT* _____ MBH [kW]
 DESIGN TEMP. RISE..... _____ °F [°C] DB
 AFUE _____ %
 CALIFORNIA SEASONAL EFFICIENCY _____ %
 (*uses blower motor heat)

SUPPLY AIR BLOWER PERFORMANCE

TOTAL AIR SUPPLY..... _____ CFM [L/s]
 TOTAL RESISTANCE EXTERNAL TO UNIT..... _____ IWG
 BLOWER SPEED..... _____ RPM
 POWER OUTPUT REQUIREMENT _____ BHP
 MOTOR RATING _____ HP [W]
 POWER INPUT REQUIREMENT _____ kW

ELECTRICAL DATA

POWER SUPPLY..... _____ Hz
 TOTAL UNIT AMPACITY..... _____ AMPS
 MINIMUM WIRE SIZE..... _____ AWG
 MAXIMUM OVERCURRENT DEVICE FUSES/HACR BREAKER _____ AMPS

FEATURES

- **PlusOne® Diagnostics:** Industry-first, 7-segment LED for quick & easy service
- **PlusOne® Ignition System:** Proven Direct Spark Ignition (DSI) for reliability and longevity
- **Low Profile, 34-inch Cabinet:** Makes our furnaces ideal for space-constrained installations
- **Hemmed Cabinet & Door Edges and Quarter-turn Door Fasteners (Upflow/Horizontal only):** Allows for safe, tool-less access and serviceability
- **Removable Heat Exchanger:** Improves serviceability. Aluminized steel construction provides maximum corrosion resistance and thermal fatigue reliability
- **Blower Shelf Design:** Ensures serviceability in all furnace orientations

FIELD INSTALLED ACCESSORIES

Filter Rack RXGF-CC*

*Downflow Top Return Mount Requires (2) 14 x 20 Filters. Filter Racks are shipped without filters. Filters available through PROSTOCK®.



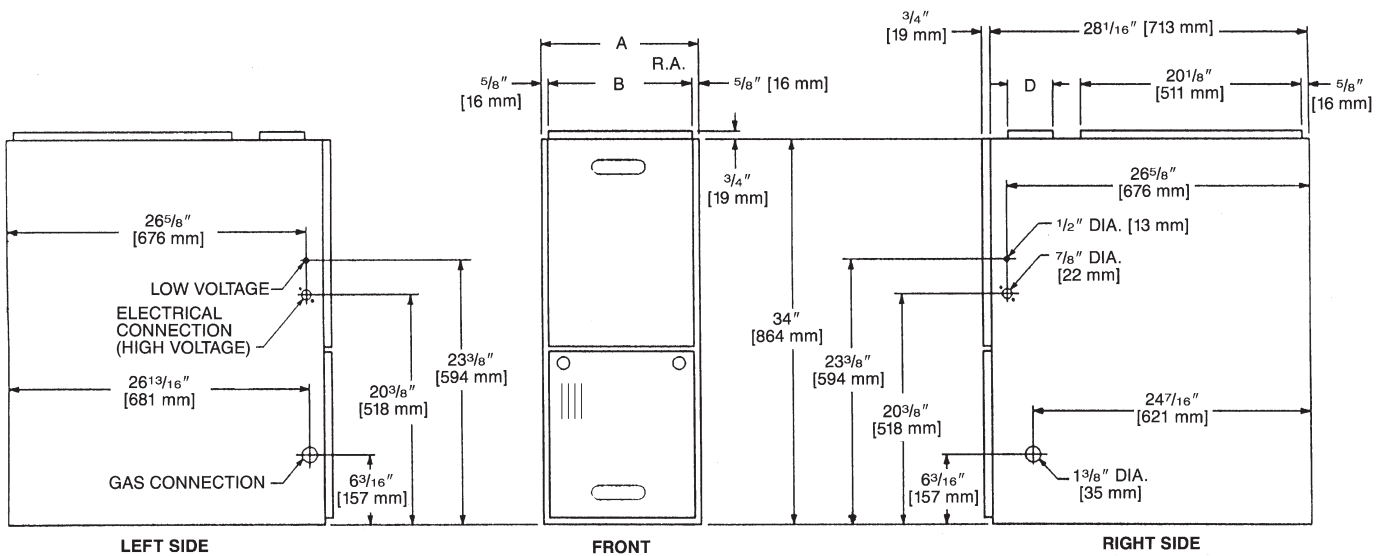
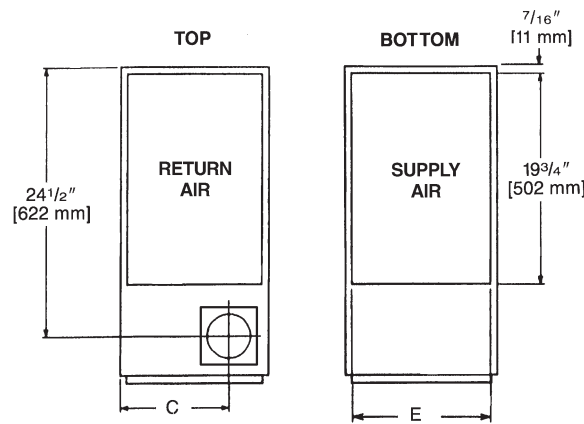

Dimensional Data—Downflow Models

MODEL (-)801T DZ	A	B	C	D	E	REDUCED CLEARANCES (IN.) [mm]					
						LEFT SIDE	RIGHT SIDE	BACK	TOP	FRONT	VENT
050	14 [356]	12 ²⁷ / ₃₂ [326]	10 ³ / ₈ [264]	①	13 ¹ / ₈ [333]	0	4 [102] ②	0	1 [25]	3 [76]	6 [152]
050417	17 ¹ / ₂ [445]	16 ¹¹ / ₃₂ [415]	12 ¹ / ₈ [308]	①	16 ⁵ / ₈ [422]	0	3 [76] ②	0	1 [25]	3 [76]	6 [152]
075521	21 [533]	19 ²⁷ / ₃₂ [504]	13 ⁷ / ₈ [352]	①	20 ¹ / ₈ [511]	0	0	0	1 [25]	3 [76]	6 [152] ③
100	21 [533]	19 ²⁷ / ₃₂ [504]	13 ⁷ / ₈ [352]	①	20 ¹ / ₈ [511]	0	0	0	1 [25]	3 [76]	6 [152] ③
125	24 ¹ / ₂ [622]	23 ¹¹ / ₃₂ [593]	15 ⁵ / ₈ [397]	①	23 ⁵ / ₈ [600]	0	0	0	1 [25]	3 [76]	6 [152] ③

NOTES: ① May require a 3" [76 mm] to 4" [102 mm] or 3" [76 mm] to 5" [127 mm] adapter.

② May be 0" [0 mm] with type B vent.

③ May be 1" [25 mm] with type B vent.

Furnaces must be vented in accordance with the National Fuel Gas Code, ANSI Z223.1 and in accordance with local codes.

[] Designates Metric Conversions

Before proceeding with installation, refer to installation instructions packaged with each model, as well as complying with all Federal, State, Provincial, and Local codes, regulations, and practices.

5600 Old Greenwood Road
Fort Smith, Arkansas 72908

© 2023 Rheem Manufacturing Company. Rheem, Ruud and Friedrich trademarks owned by Rheem Manufacturing Company.

"In keeping with its policy of continuous progress and product improvement, Rheem reserves the right to make changes without notice."