



FRIEDRICH

1 8 8 3

Endeavor™ Line Air Handlers



FRH2TZ

Constant Torque Motor

Two-Stage Airflow

Efficiencies: 13.4 to 14.3 SEER2



Table of Contents

Features & Benefits	3
Model Number Identification	4
Dimensional Data	5
Unit Dimensions & Weights	6
Airflow Directional Data	7
Airflow Performance Data	8-12
Electrical Data	13-16
Limited Warranty	20

Features and Benefits

- **Quiet Operation¹:** Provided by a cabinet construction with 1.0 inch of foil faced insulation for quieter sound characteristics
- **Aluminum Indoor Coil Design:** Constructed of aluminum fins bonded to internally grooved aluminum tubing and are more corrosion resistant
- **Versatile 4-Way Convertible Compact Design:** Allow for upflow, downflow, horizontal left and right applications even in the smallest of spaces
- **Rugged Steel, Compact Cabinet Construction:** Designed for added strength and versatility
- **Field Installed Auxiliary Heater Kits:** Provided exact heat for indoor comfort and include circuit breakers which meet UL and cUL requirements for service disconnect
- **Less than 2% Cabinet Air Leakage at 1-inch H₂O:** When tested in accordance with ASHRAE Standard 193

¹Based on manufacturer's air handler offering, and the product's airflow stages, motor type and cabinet insulation. Sound levels are also dependent on air handler location and installation.

Air Handlers

<u>FR</u>	<u>H</u>	<u>2</u>	<u>T</u>	<u>Z</u>	<u>36</u>	<u>17</u>	<u>S</u>	<u>T</u>	<u>A</u>	<u>N</u>	<u>N</u>	<u>A</u>
Brand	Product Category	Stages of Airflow	Motor Type	Refrigerant	Capacity BTU/HR	Width	Coil Size	Metering Device	Major Series*	Controls	Coil Series	Voltage
FR - Friedrich®	H - Air Handlers	2 - Two-Stage	T - Constant Torque	Z - R-410A	24 - 24,000 [7.03 kW] 36 - 36,000 [10.55 kW] 48 - 48,000 [14.07 kW] 60 - 60,000 [17.58 kW]	17 - 17.5" 21 - 21" 24 - 24.5"	S - Standard Eff.	T - TEV	A - 1st Design	N - Non-comm	N - N Coil A - A Coil	A - 1ph, 115/60 J - 1ph, 208-240/60

[] Designates Metric Conversions

Available Models
FRH2TZ2417STANNA
FRH2TZ2417STANNJ
FRH2TZ3617STANNA
FRH2TZ3617STANNJ
FRH2TZ3621MTANAA
FRH2TZ3621MTANAJ
FRH2TZ3621MTANNA
FRH2TZ3621MTANNJ
FRH2TZ3621STANNA
FRH2TZ3621STANNJ
FRH2TZ4821STANAA
FRH2TZ4821STANAJ
FRH2TZ4821STANNA
FRH2TZ4821STANNJ
FRH2TZ4824STANNA
FRH2TZ4824STANNJ
FRH2TZ6021STANAA
FRH2TZ6021STANAJ
FRH2TZ6024STANNA
FRH2TZ6024STANNJ

Standard Equipment
Pre-painted cabinet
Four leg blower mount motor
Slide out blower design for service and maintenance convenience
Traditional open wire element design for heat applications
Field convertible for vertical downflow, horizontal left hand or right hand air supply
3 combustible floor base accessories fit all sizes for downflow installations
Indoor coil design provides low air side pressure drop, high performance and extremely compact size
Expansion valve on indoor coil provides for operation with air conditioning or heat pump
Coils are tested at the factory with an extensive refrigerant leak check
Coils have copper sweat refrigerant connections and utilize chatleff metering device connections
Supply duct flanges
Side or top provisions for field electrical connections
Inside connection for high voltage wiring
Outside connection for low voltage wiring
Concentric knockouts are provided for power connection
Front refrigerant and drain connections

Unit Dimensions

ELECTRICAL CONNECTIONS
MAY EXIT TOP OR EITHER SIDE
HIGH VOLTAGE CONNECTION 7/8" [22.2 mm],
1 3/32" [27.8 mm], 1 3/16" [50 mm] DIA, KNOCKOUTS.

LOW VOLTAGE CONNECTION
5/8" [15.9 mm] AND 7/8" [22.2 mm] KNOCKOUT

AUXILIARY DRAIN CONNECTION
3/4" [19.1 mm] FEMALE PIPE THREAD (NPT)
HORIZONTAL APPLICATION ONLY

PRIMARY DRAIN CONNECTION
3/4" [19.1 mm] FEMALE PIPE THREAD (NPT)

AUXILIARY DRAIN CONNECTION
3/4" [19.1 mm] FEMALE PIPE THREAD (NPT)
UPFLOW/DOWNFLOW APPLICATION ONLY

LIQUID LINE CONNECTION
COPPER (SWEAT)

VAPOR LINE CONNECTION
COPPER (SWEAT)

SUPPLY AIR ↑

NOTE: 24" CLEARANCE REQUIRED IN FRONT OF
UNIT FOR FILTER AND COIL MAINTENANCE.

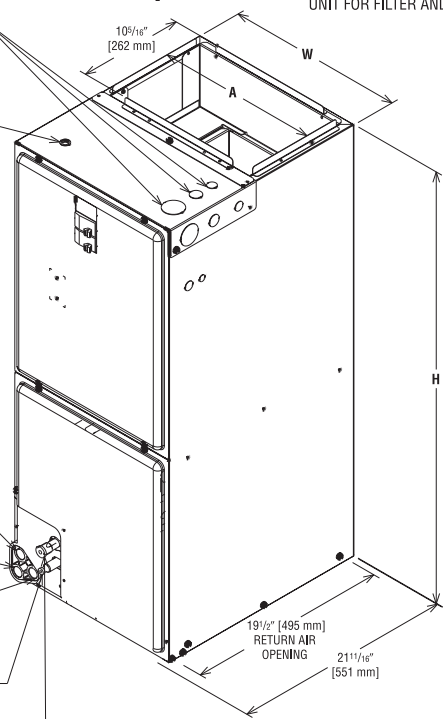

UPFLOW UNIT SHOWN:
UNIT MAY BE INSTALLED UPFLOW, DOWNFLOW,
HORIZONTAL RIGHT OR LEFT AIR SUPPLY.

Return Air Opening Dimensions

Model Cabinet Size	Return Air Opening Width (Inches)	Return Air Opening Depth/Length (Inches)
17	15 7/8	19 3/4
21	19 3/8	19 3/4
24	22 7/8	19 3/4

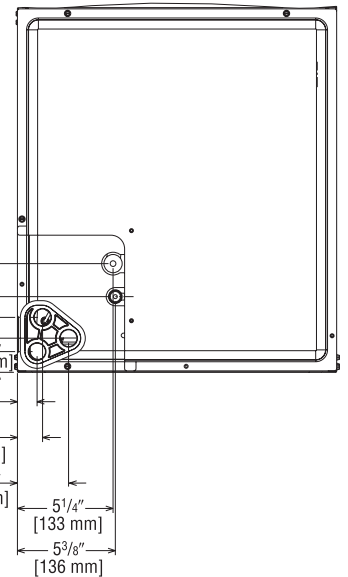

UPFLOW UNIT SHOWN:
UNIT MAY BE INSTALLED UPFLOW,
DOWNFLOW, HORIZONTAL RIGHT
OR LEFT AIR SUPPLY.

[] Designates Metric Conversions
() Designates Unit with Double Coil Cabinet

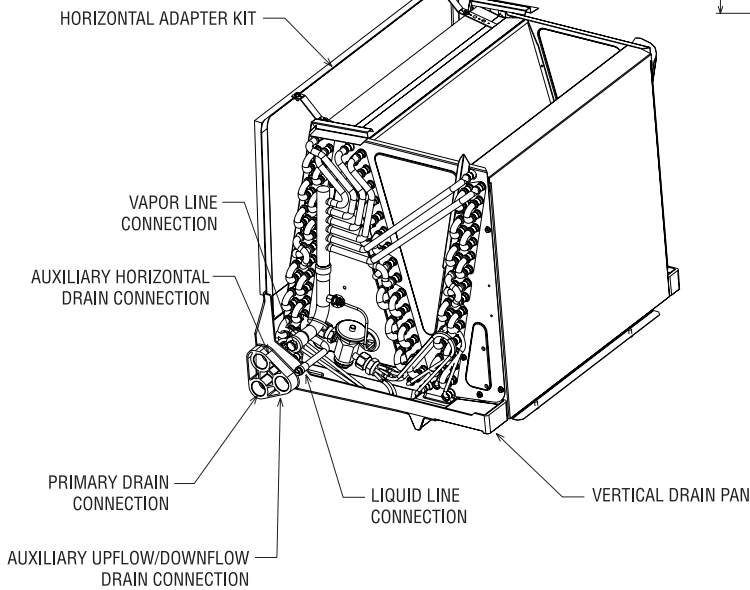

Unit Dimensions & Weights

Model Size FRH2TZ	Refrigerant Connections Sweat (In.) [mm] ID		Unit Width "W" In. [mm]	Unit Height "H" In. [mm]	Supply Duct "A" In. [mm]	Air Flow CFM (Nom.) [L/s]		Unit Weight/Shipping Weight (Lbs.) [kg]
	Liquid	Vapor				Lo	Hi	Unit With Coil (Max. KW)
2417ST	3/8 [9.53]	3/4 [19.05]	17 1/2 [445]	42 1/2 [1080]	16 [406]	600 [283]	800 [378]	92/106 [42/48]
3617ST	3/8 [9.53]	3/4 [19.05]	17 1/2 [445]	42 1/2 [1080]	16 [406]	1000 [472]	1200 [566]	96/110 [44/50]
3621ST	3/8 [9.53]	3/4 [19.05]	21 [533]	42 1/2 [1080]	19 1/2 [495]	525 [248]	700 [330]	111/126 [50/57]
3621MT**A	3/8 [9.53]	7/8 [22.23]	21 [533]	50 1/2 [1282]	19 1/2 [495]	1000 [472]	1200 [566]	126/142 [57/64]
3621MT**N	3/8 [9.53]	7/8 [22.23]	21 [533]	57 [1448]	19 1/2 [495]	1000 [472]	1200 [566]	137/149 [62/68]
4821ST**N	3/8 [9.53]	7/8 [22.23]	21 [533]	50 1/2 [1282]	19 1/2 [495]	1400 [661]	1600 [755]	128/144 [56/65]
4821ST**A	3/8 [9.53]	7/8 [22.23]	21 [533]	57 [1448]	19 1/2 [495]	1400 [661]	1600 [755]	139/151 [63/68]
4824ST**N	3/8 [9.53]	7/8 [22.23]	24 1/2 [622]	55 1/2 [1410]	23 [584]	1050 [495]	1400 [660]	128/146 [58/66]
6021ST**A	3/8 [9.53]	7/8 [22.23]	21 [533]	57 [1448]	19 1/2 [495]	1600 [755]	1725 [814]	139/151 [63/68]
6024ST	3/8 [9.53]	7/8 [22.23]	24 1/2 [622]	55 1/2 [1410]	23 [584]	1200 [566]	1600 [755]	161/178 [73/81]

[] Designates Metric Conversions

Airflow Directional Data

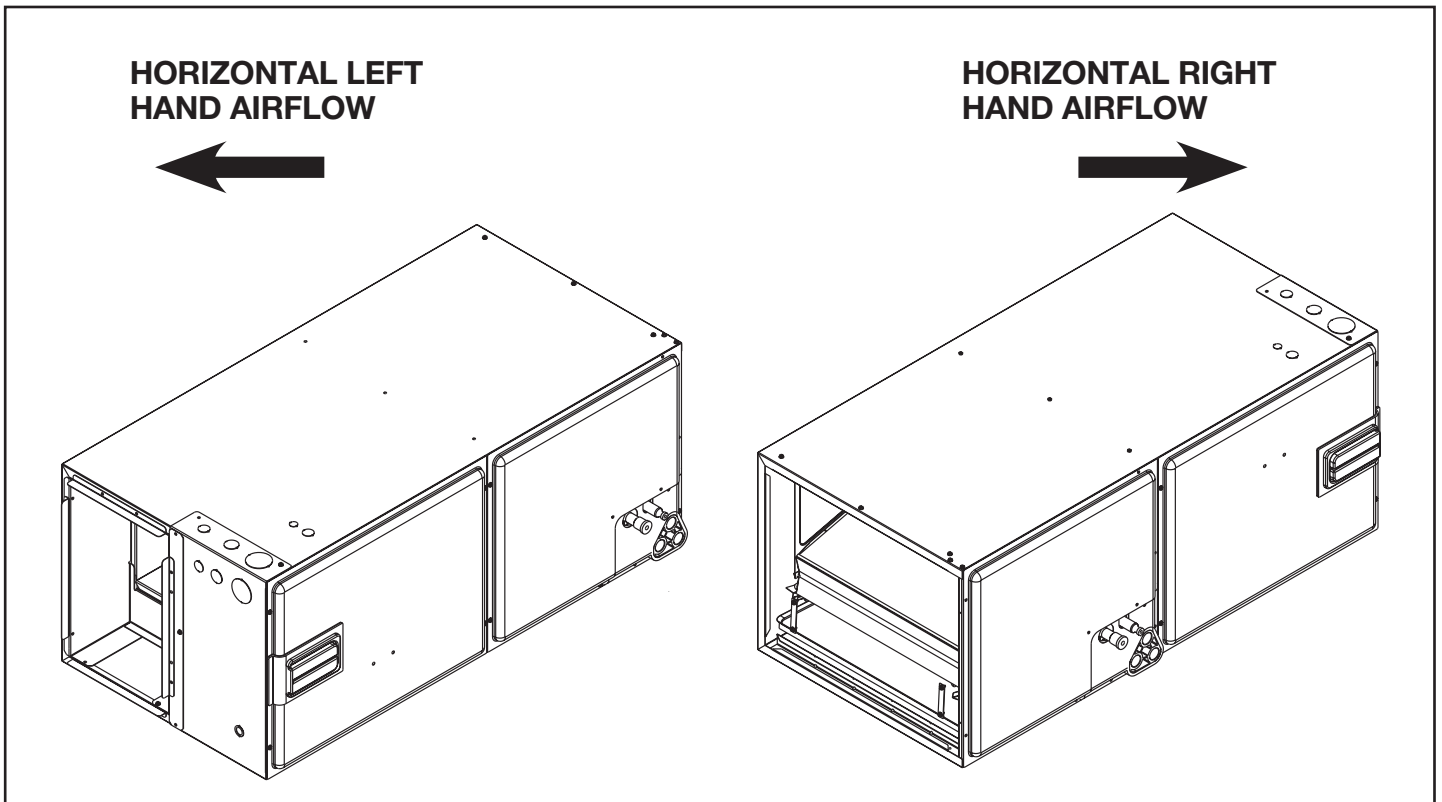
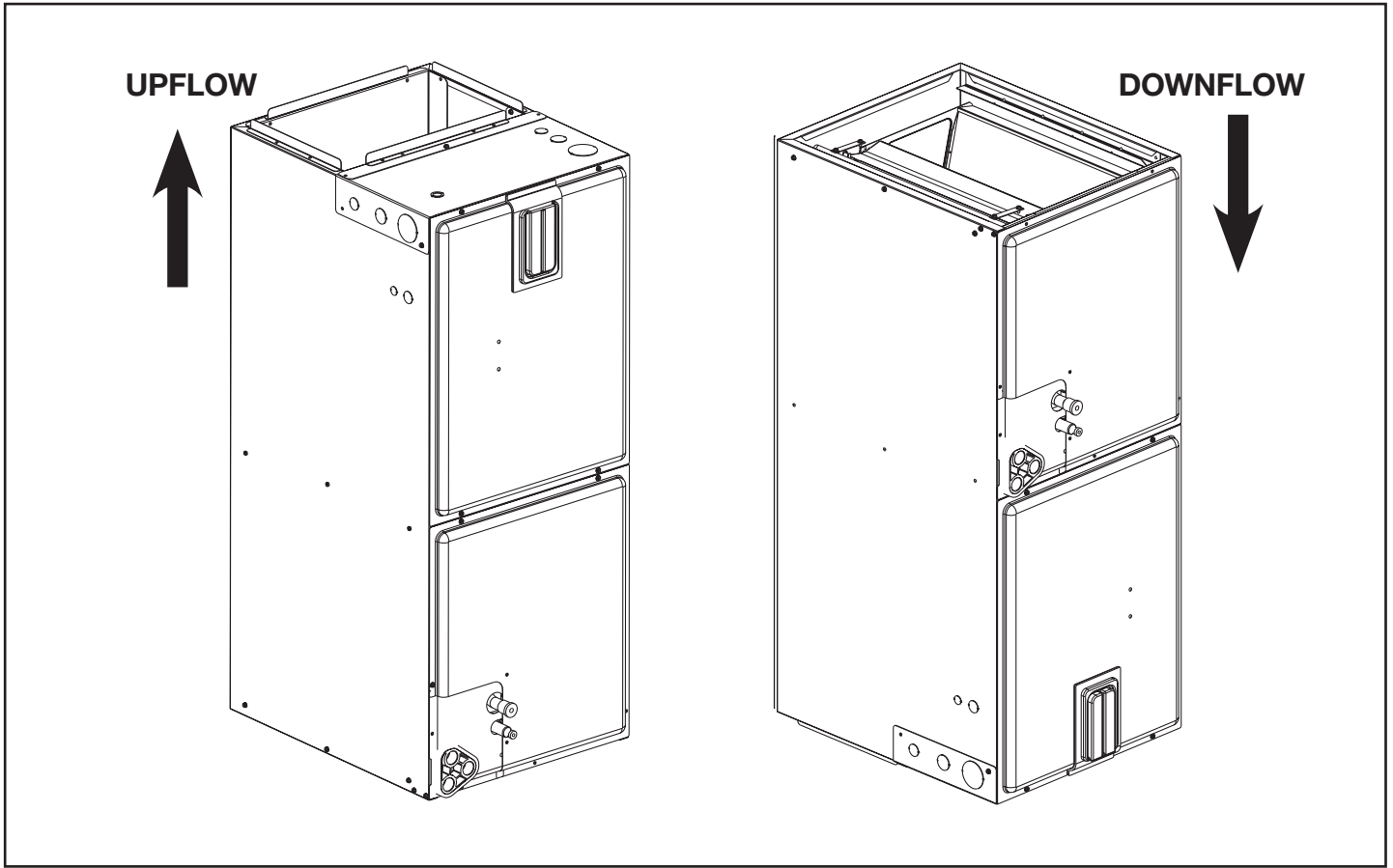

Airflow Performance

Airflow performance data is based on cooling performance with a coil and no filter in place. Select performance table for appropriate unit size, voltage and number of electric heaters to be used. Make sure external static applied to unit allows operation within the minimum and maximum limits shown in

table below for both cooling and electric heat operation. For optimum blower performance, operate the unit in the .3 [8 mm] to .7 inches [18 mm] W.C. external static range. Units with coils should be applied with a minimum of .1 inch [3 mm] W.C. external static range.

Airflow Operating Limits

Model Cabinet Size	17		17/21		21			24	
Cooling BTUH x 1000 Cooling Tons Nominal	-18 1.5	-24 2	-30 2.5	-36 3	-42 3.5	-48 4	-60 5	-48 4	-60 5
Heat Pump or Air Conditioning Maximum Heat/Cool CFM [L/s] (37.5 CFM [18 L/s]/1,000 BTUH) (450 CFM [212 L/s]/Ton Nominal)	675 [319]	900 [425]	1125 [531]	1350 [637]	1575 [743]	1800 [850]	1925 [907]	1800 [850]	1930 [911]
Heat Pump or Air Conditioning Nominal Heat/Cool CFM [L/s] (33.3 CFM [16 L/s]/1,000 BTUH) (400 CFM [189 L/s]/Ton Nominal)	600 [283]	800 [378]	1000 [472]	1200 [566]	1400 [661]	1600 [755]	1750 [826]	1600 [755]	1800 [850]
Heat Pump or Air Conditioning Minimum Heat/Cool CFM [L/s] (30.0 CFM [14 L/s]/1,200 BTUH) (360 CFM [170 L/s]/Ton Nominal)	540 [255]	720 [330]	900 [425]	1080 [510]	1260 [595]	1440 [680]	1575 [743]	1440 [680]	1620 [765]
Maximum KW Electric Heating & Minimum Electric Heat CFM [L/s]	13 487 [230]	13 617 [291]	18 814 [384]	18 1054 [497]	20 1171 [553]	25 1502 [709]	25 1502 [709]	25 1502 [709]	30 1666 [786]
Maximum Electric Heat Rise °F [°C]	80 [26.7]	63 [17.2]	66 [18.9]	51 [10.6]	49 [9.4]	50 [10]	50 [10]	50 [10]	54 [12.2]

[] Designates Metric Conversions

115V/208V/240V Airflow Performance Data—FRH2TZ (Constant Torque (ECM) Motor)

Model No. FRH2TZ	Tonnage Application	Motor Speed From Factory	Blower Size/ Motor HP [W] # of Speed	Motor Speed	CFM/RPM/WATTS — Dry Coil—No Filter										
					External Static Pressure Inches of W.C.										
					0.1	0.2	0.3	0.4	0.5	0.6	0.7	0.8	0.9	1	
2417ST No Heater	1.5 Ton	5	10x8 1/3 HP [373] 5 Speed	2	CFM	835	664	501	434	362	294	—	—	—	—
					RPM	570	581	617	687	746	814	—	—	—	—
					Watts	89	70	59	66	72	78	—	—	—	—
				3	CFM	—	—	—	—	649	589	545	489	441	383
					RPM	—	—	—	—	791	851	899	951	990	1049
					Watts	—	—	—	—	121	129	136	144	149	159
2417ST with 18 kW Heater	1.5 Ton	5	10x8 1/3 HP [373] 5 Speed	2	CFM	810	644	486	421	352	285	—	—	—	—
					RPM	599	610	648	721	783	854	—	—	—	—
					Watts	96	77	65	71	78	85	—	—	—	—
				3	CFM	—	—	—	—	629	572	528	474	428	372
					RPM	—	—	—	—	830	894	944	998	1040	1101
					Watts	—	—	—	—	132	141	148	157	163	174
2417ST No Heater	2 Ton	5	10x8 1/3 HP [373] 5 Speed	4	CFM	829	662	555	482	430	363	—	—	—	—
					RPM	573	584	635	705	757	814	—	—	—	—
					Watts	88	70	68	75	80	86	—	—	—	—
				5	CFM	—	—	—	—	799	759	722	670	628	583
					RPM	—	—	—	—	830	875	920	975	1016	1057
					Watts	—	—	—	—	164	172	181	190	199	206
2417ST with 18 kW Heater	2 Ton	5	10x8 1/3 HP [373] 5 Speed	4	CFM	805	642	538	467	417	352	—	—	—	—
					RPM	602	613	666	741	795	855	—	—	—	—
					Watts	96	76	74	82	87	94	—	—	—	—
				5	CFM	—	—	—	—	775	736	701	650	609	566
					RPM	—	—	—	—	871	919	966	1024	1066	1110
					Watts	—	—	—	—	178	187	197	207	217	225
3617ST No Heater	2.5 Ton	5	10x10 1/2 HP [373] 5 Speed	2	CFM	857	721	665	594	539	473	—	—	—	—
					RPM	586	596	648	712	768	827	—	—	—	—
					Watts	91	77	83	91	106	114	—	—	—	—
				3	CFM	—	—	—	—	943	902	859	814	771	723
					RPM	—	—	—	—	859	899	920	955	995	1030
					Watts	—	—	—	—	204	212	221	230	240	249
3617ST with 18 kW Heater	2.5 Ton	5	10x10 1/2 HP [373] 5 Speed	2	CFM	831	700	645	576	523	459	—	—	—	—
					RPM	615	625	680	748	807	869	—	—	—	—
					Watts	99	84	90	99	116	124	—	—	—	—
				3	CFM	—	—	—	—	914	875	833	790	748	701
					RPM	—	—	—	—	902	944	966	1003	1045	1082
					Watts	—	—	—	—	222	231	241	251	261	271
3617ST No Heater	3 Ton	5	10x10 1/2 HP [373] 5 Speed	4	CFM	855	762	705	655	597	536	—	—	—	—
					RPM	588	617	662	716	777	831	—	—	—	—
					Watts	103	87	93	100	116	115	—	—	—	—
				5	CFM	—	—	—	—	1094	1056	1016	974	937	901
					RPM	—	—	—	—	895	927	953	991	1021	1050
					Watts	—	—	—	—	270	280	287	299	308	317

[] Designates Metric Conversions

115V/208V/240V Airflow Performance Data—FRH2TZ (Constant Torque (ECM) Motor) (Con't.)

Model No. FRH2TZ	Tonnage Application	Motor Speed From Factory	Blower Size/ Motor HP [W] # of Speed	Motor Speed	CFM/RPM/WATTS — Dry Coil—No Filter										
					External Static Pressure Inches of W.C.										
					0.1	0.2	0.3	0.4	0.5	0.6	0.7	0.8	0.9	1	
3617ST with 18 kW Heater	3 Ton	5	10x10 1/2 HP [373] 5 Speed	4	CFM	829	739	683	635	579	520	—	—	—	—
					RPM	618	647	696	752	816	872	—	—	—	—
					Watts	112	95	101	109	126	125	—	—	—	—
				5	CFM	—	—	—	—	1061	1024	986	945	909	874
					RPM	—	—	—	—	940	973	1001	1040	1072	1102
					Watts	—	—	—	—	294	305	313	326	336	345
3621ST No Heater	2.5 Ton	5	10x10 1/2 HP [373] 5 Speed	2	CFM	987	793	662	611	549	489	—	—	—	—
					RPM	591	598	640	700	755	817	—	—	—	—
					Watts	97	74	66	75	80	89	—	—	—	—
				3	CFM	—	—	—	—	941	898	852	809	755	712
					RPM	—	—	—	—	821	864	910	955	1006	1042
					Watts	—	—	—	—	171	179	188	196	207	216
3621ST with 18 kW Heater	2.5 Ton	5	10x10 1/2 HP [373] 5 Speed	2	CFM	957	763	632	581	519	459	—	—	—	—
					RPM	616	623	665	725	780	842	—	—	—	—
					Watts	92	69	61	70	75	84	—	—	—	—
				3	CFM	—	—	—	—	911	868	822	779	725	682
					RPM	—	—	—	—	846	889	935	980	1031	1067
					Watts	—	—	—	—	166	174	183	191	202	211
3621ST No Heater	3 Ton	5	10x10 1/2 HP [373] 5 Speed	4	CFM	983	808	706	654	580	529	—	—	—	—
					RPM	595	600	623	641	695	770	—	—	—	—
					Watts	96	75	72	79	87	92	—	—	—	—
				5	CFM	—	—	—	—	1099	1058	1017	975	937	905
					RPM	—	—	—	—	859	895	939	983	1020	1054
					Watts	—	—	—	—	223	231	241	251	263	276
3621ST with 18 kW Heater	3 Ton	5	10x10 1/2 HP [373] 5 Speed	4	CFM	953	778	676	624	550	499	—	—	—	—
					RPM	620	625	648	666	720	795	—	—	—	—
					Watts	91	70	67	74	82	87	—	—	—	—
				5	CFM	—	—	—	—	1069	1028	987	945	907	875
					RPM	—	—	—	—	884	920	964	1008	1045	1079
					Watts	—	—	—	—	218	226	236	246	258	271
4821ST***N No Heater	3.5 Ton	5	10x10 3/4 HP [373] 5 Speed	2	CFM	892	817	737	632	564	487	—	—	—	—
					RPM	611	660	718	817	864	910	—	—	—	—
					Watts	81	89	96	108	114	120	—	—	—	—
				3	CFM	—	—	—	—	1336	1290	1240	1198	1147	1085
					RPM	—	—	—	—	1006	1048	1084	1121	1170	1235
					Watts	—	—	—	—	341	356	367	379	396	421
4821ST***N with 20 kW Heater	3.5 Ton	5	10x10 3/4 HP [373] 5 Speed	2	CFM	892	817	737	632	564	487	—	—	—	—
					RPM	611	660	718	817	864	910	—	—	—	—
					Watts	81	89	96	108	114	120	—	—	—	—
				3	CFM	—	—	—	—	1336	1290	1240	1198	1147	1085
					RPM	—	—	—	—	1006	1048	1084	1121	1170	1235
					Watts	—	—	—	—	341	356	367	379	396	421

[] Designates Metric Conversions

115V/208V/240V Airflow Performance Data—FRH2TZ (Constant Torque (ECM) Motor) (Con't.)

Model No. FRH2TZ	Tonnage Application	Motor Speed From Factory	Blower Size/ Motor HP [W] # of Speed	Motor Speed	CFM/RPM/WATTS — Dry Coil—No Filter										
					External Static Pressure Inches of W.C.										
					0.1	0.2	0.3	0.4	0.5	0.6	0.7	0.8	0.9	1	
4821ST***N No Heater	4 Ton	5	10x10 3/4 HP [373] 5 Speed	4	CFM	1106	1032	973	901	819	712	—	—	—	—
					RPM	698	727	770	821	893	972	—	—	—	—
					Watts	129	134	142	150	163	178	—	—	—	—
				5	CFM	—	—	—	—	1472	1430	1392	1349	1308	1272
					RPM	—	—	—	—	1068	1104	1134	1171	1205	1243
					Watts	—	—	—	—	430	445	457	473	487	504
4821ST***N with 25 kW Heater	4 Ton	5	10x10 3/4 HP [373] 5 Speed	4	CFM	1106	1032	973	901	819	712	—	—	—	—
					RPM	698	727	770	821	893	972	—	—	—	—
					Watts	129	134	142	150	163	178	—	—	—	—
				5	CFM	—	—	—	—	1472	1430	1392	1349	1308	1272
					RPM	—	—	—	—	1068	1104	1134	1171	1205	1243
					Watts	—	—	—	—	430	445	457	473	487	504
4824ST No Heater	3.5 Ton	5	10x10 3/4 HP [373] 5 Speed	2	CFM	964	882	809	676	581	464	—	—	—	—
					RPM	445	501	552	610	651	698	—	—	—	—
					Watts	79	88	96	104	111	113	—	—	—	—
				3	CFM	—	—	—	—	1372	1312	1257	1201	1126	1035
					RPM	—	—	—	—	765	803	837	875	910	948
					Watts	—	—	—	—	292	305	317	330	342	354
4824ST with 20 kW Heater	3.5 Ton	5	10x10 3/4 HP [373] 5 Speed	2	CFM	934	852	779	646	551	434	—	—	—	—
					RPM	470	526	577	635	676	723	—	—	—	—
					Watts	74	83	91	99	106	108	—	—	—	—
				3	CFM	—	—	—	—	1342	1282	1227	1171	1096	1005
					RPM	—	—	—	—	790	828	862	900	935	973
					Watts	—	—	—	—	287	300	312	325	337	349
4824ST No Heater	4 Ton	5	10x10 3/4 HP [373] 5 Speed	4	CFM	1152	1080	1004	926	837	734	—	—	—	—
					RPM	493	539	587	636	687	726	—	—	—	—
					Watts	113	122	131	141	151	159	—	—	—	—
				5	CFM	—	—	—	—	1507	1459	1412	1360	1308	1241
					RPM	—	—	—	—	798	833	861	894	922	960
					Watts	—	—	—	—	350	364	378	389	400	415
4824ST with 20 kW Heater	4 Ton	5	10x10 3/4 HP [373] 5 Speed	4	CFM	1122	1050	974	896	807	704	—	—	—	—
					RPM	518	564	612	661	712	751	—	—	—	—
					Watts	108	117	126	136	146	154	—	—	—	—
				5	CFM	—	—	—	—	1477	1429	1382	1330	1278	1211
					RPM	—	—	—	—	823	858	886	919	947	985
					Watts	—	—	—	—	345	359	373	384	395	410
6024ST No Heater	4.5 Ton	5	11x11 3/4 HP [373] 5 Speed	2	CFM	1321	1127	914	512	398	321	—	—	—	—
					RPM	567	573	579	588	629	667	—	—	—	—
					Watts	164	138	115	78	81	86	—	—	—	—
				3	CFM	—	—	—	—	1511	1467	1414	1356	1301	1243
					RPM	—	—	—	—	822	850	879	906	937	968
					Watts	—	—	—	—	375	386	397	405	418	431

[] Designates Metric Conversions

115V/208V/240V Airflow Performance Data—FRH2TZ (Constant Torque (ECM) Motor) (Con't.)

Model No. FRH2TZ	Tonnage Application	Motor Speed From Factory	Blower Size/ Motor HP [W] # of Speed	Motor Speed	CFM/RPM/WATTS — Dry Coil—No Filter										
					External Static Pressure Inches of W.C.										
					0.1	0.2	0.3	0.4	0.5	0.6	0.7	0.8	0.9	1	
6024ST with 25 kW Heater	4.5 Ton	5	11x11 3/4 HP [373] 5 Speed	2	CFM	1281	1093	886	497	386	311	—	—	—	—
					RPM	595	602	608	618	660	700	—	—	—	—
					Watts	179	150	126	85	88	93	—	—	—	—
				3	CFM	—	—	—	—	1466	1423	1372	1315	1262	1205
					RPM	—	—	—	—	864	893	923	951	984	1016
					Watts	—	—	—	—	408	420	432	442	456	470
6024ST No Heater	5 Ton	5	11x11 3/4 HP [373] 5 Speed	4	CFM	1367	1193	1097	1032	957	869	—	—	—	—
					RPM	583	588	622	661	700	746	—	—	—	—
					Watts	176	154	156	165	174	184	—	—	—	—
				5	CFM	—	—	—	—	1877	1837	1797	1754	1707	1673
					RPM	—	—	—	—	924	946	967	995	1018	1045
					Watts	—	—	—	—	602	614	628	643	656	673
6024ST with 30 kW Heater	5 Ton	5	11x11 3/4 HP [373] 5 Speed	4	CFM	1326	1157	1064	1001	928	843	—	—	—	—
					RPM	612	618	653	694	735	783	—	—	—	—
					Watts	192	167	170	180	190	200	—	—	—	—
				5	CFM	—	—	—	—	1821	1781	1743	1701	1656	1623
					RPM	—	—	—	—	970	994	1016	1045	1069	1097
					Watts	—	—	—	—	656	670	684	701	714	734
6021ST No Heater	4.5 Ton	5	11x11 3/4 HP [373] 5 Speed	2	CFM	1120	1061	997	875	819	777	—	—	—	—
					RPM	657	710	773	859	892	917	—	—	—	—
					Watts	133	143	154	170	176	180	—	—	—	—
				3	CFM	—	—	—	—	1515	1464	1416	1363	1295	1248
					RPM	—	—	—	—	1047	1089	1134	1175	1228	1259
					Watts	—	—	—	—	439	454	471	486	507	519
6021ST with 25 kW Heater	4.5 Ton	5	11x11 3/4 HP [373] 5 Speed	2	CFM	1080	1021	957	835	779	737	—	—	—	—
					RPM	682	735	798	884	917	942	—	—	—	—
					Watts	128	138	149	165	171	175	—	—	—	—
				3	CFM	—	—	—	—	1475	1424	1376	1323	1255	1208
					RPM	—	—	—	—	1072	1114	1159	1200	1253	1284
					Watts	—	—	—	—	434	449	466	481	502	514
6021ST No Heater	5 Ton	5	11x11 3/4 HP [373] 5 Speed	4	CFM	1223	1171	1113	1057	967	892	—	—	—	—
					RPM	702	750	807	859	927	966	—	—	—	—
					Watts	167	178	190	201	216	224	—	—	—	—
				5	CFM	—	—	—	—	1896	1861	1829	1790	1730	1568
					RPM	—	—	—	—	1180	1210	1240	1277	1301	1302
					Watts	—	—	—	—	727	742	759	780	771	683
6021ST with 30 kW Heater	5 Ton	5	11x11 3/4 HP [373] 5 Speed	4	CFM	1183	1131	1073	1017	927	852	—	—	—	—
					RPM	727	775	832	884	952	991	—	—	—	—
					Watts	162	173	185	196	211	219	—	—	—	—
				5	CFM	—	—	—	—	1856	1821	1789	1750	1690	1528
					RPM	—	—	—	—	1205	1235	1265	1302	1326	1327
					Watts	—	—	—	—	722	737	754	775	766	678

[] Designates Metric Conversions

Electrical Data—Blower Motor Only—No Electric Heat FRH2TZ

Model FRH2TZ	Voltage	Phase *	Hertz	HP [W]	RPM	Speeds	Motor Amps.	Minimum Circuit Ampacity	Maximum Overcurrent Protection
2417S	115	1	60	1/3 [249]	300-1100	4	2.7	4	15
3617S/3621M				1/2 [373]	300-1100	4	3.4	5	15
4821S/4821M/4824S				3/4 [559]	300-1100	4	6.5	9	15
6021S/6024S				3/4 [559]	300-1100	4	8.0	10	15
2417S	208/240	1	60	1/3 [249]	300-1100	4	1.8	3	15
3617S/3621M				1/2 [373]	300-1100	4	2.4	3	15
4821S/4821M/4824S				3/4 [559]	300-1100	4	3.7	5	15
6021S/6024S				3/4 [559]	300-1100	4	5.6	7	15

[] Designates Metric Conversions

Electrical Data—With Electric Heat FRH2TZ

Installation of the U.L. Listed original equipment manufacturer provided heater kits listed in the following table is recommended for all auxiliary heating requirements.

Air Handler Model	Heater Model Number	Heater kW (208/240V)	Ph/Hz	No. Elements - kW per	Type Supply Circuit Single Circuit Multiple Circuit	Heater Amps.	Motor Amps	Minimum Circuit Ampacity	Maximum Overcurrent Protection
2417S	RXBH-17?03J	2.25/3.0	1/60	1-3.0	SINGLE	10.8/12.5	1.8	16/18	20/20
	RXBH-1724?03J	2.25/3.0	1/60	1-3.0	SINGLE	10.8/12.5	1.8	16/18	20/20
	RXBH-1724?05J	3.6/4.8	1/60	1-4.8	SINGLE	17.3/20.0	1.8	24/28	30/30
	RXBH-1724?07J	5.4/7.2	1/60	2-3.6	SINGLE	26.0/30.0	1.8	35/40	40/40
	RXBH-1724?10J	7.2/9.6	1/60	2-4.8	SINGLE	34.6/40.0	1.8	46/53	50/60
	RXBH-1724A13J	9.4/12.5	1/60	3/4/17	SINGLE	45.1/52.1	1.8	59/68	60/70
	RXBH-1724A13J	3.1/4.2	1/60	1/4/17	MULTIPLE CKT 1	15.0/17.4	1.8	21/24	30/30
		6.3/8.3	1/60	2/4/17	MULTIPLE CKT 2	30.1/34.7	0.0	38/44	40/50
	RXBH-1724A07C	5.4/7.2	3/60	3-2.4	SINGLE	15.0/17.3	1.8	21/24	30/30
	RXBH-1724A10C	7.2/9.6	3/60	3-3.2	SINGLE	20.0/23.1	1.8	28/32	30/40
RXBH-1724A13C	9.4/12.5	3/60	3/4/17	SINGLE	26.1/30.1	1.8	35/40	40/40	
3617S	RXBH-17?03J	2.25/3.0	1/60	1-3.0	SINGLE	10.8/12.5	2.8	17/20	20/20
3617S 3621M	RXBH-1724?03J	2.25/3.0	1/60	1-3.0	SINGLE	10.8/12.5	2.8	17/20	20/20
	RXBH-1724?05J	3.6/4.8	1/60	1-4.8	SINGLE	17.3/20.0	2.8	26/29	30/30
	RXBH-1724?07J	5.4/7.2	1/60	2-3.6	SINGLE	26.0/30.0	2.8	36/41	40/50
	RXBH-1724?10J	7.2/9.6	1/60	2-4.8	SINGLE	34.6/40.0	2.8	47/54	50/60
	RXBH-1724A13J	9.4/12.5	1/60	3/4/17	SINGLE	45.1/52.1	2.8	60/69	60/70
	RXBH-1724A13J	3.1/4.2	1/60	1/4/17	MULTIPLE CKT 1	15.0/17.4	2.8	23/26	30/30
		6.3/8.3	1/60	2/4/17	MULTIPLE CKT 2	30.1/34.7	0.0	38/44	40/50
	RXBH-1724A15J	10.8/14.4	1/60	3-4.8	SINGLE	51.9/60.0	2.8	69/79	70/80
	RXBH-1724A15J	3.6/4.8	1/60	1-4.8	MULTIPLE CKT 1	17.3/20.0	2.8	26/29	30/30
		7.2/9.6	1/60	2-4.8	MULTIPLE CKT 2	34.6/40.0	0.0	44/50	50/50
	RXBH-1724A18J	12.8/17.0	1/60	3/5/68	SINGLE	61.6/70.8	2.8	81/92	90/100
	RXBH-1724A18J	4.3/5.7	1/60	1/5/68	MULTIPLE CKT 1	20.5/23.6	2.8	30/33	30/40
		8.5/11.3	1/60	2/5/68	MULTIPLE CKT 2	41.1/47.2	0.0	52/59	60/60
	RXBH-1724A07C	5.4/7.2	3/60	3-2.4	SINGLE	15.0/17.3	2.8	23/26	30/30
	RXBH-1724A10C	7.2/9.6	3/60	3-3.2	SINGLE	20.0/23.1	2.8	29/33	30/40
	RXBH-1724A13C	9.4/12.5	3/60	3/4/17	SINGLE	26.1/30.1	2.8	37/42	40/50

Electrical Data—With Electric Heat FRH2TZ (Con't.)

Air Handler Model	Heater Model Number	Heater kW (208/240V)	Ph/Hz	No. Elements - kW per	Type Supply Circuit Single Circuit Multiple Circuit	Heater Amps.	Motor Amps	Minimum Circuit Ampacity	Maximum Overcurrent Protection
3617S 3621M	RXBH-1724A15C	10.8/14.4	3/60	3-4.8	SINGLE	30.0/34.6	2.8	41/47	50/50
	RXBH-1724A18C	12.8/17.0	3/60	3/5/68	SINGLE	35.5/41.0	2.8	48/55	50/60
3617S	RXBH-17A07D	7.2	3/60	3-2.4	SINGLE	8.7	2.8	15/15	20/20
	RXBH-17A10D	9.6	3/60	3-3.2	SINGLE	11.6	2.8	18/18	20/20
	RXBH-17A15D	14.4	3/60	3-4.8	SINGLE	17.3	2.8	26/26	30/30
	RXBH-17A18D	17.0	3/60	3/5/68	SINGLE	20.4	2.8	29/29	30/30
4821S 4821M 4824S	RXBH-1724?05J	3.6/4.8	1/60	1-4.8	SINGLE	17.3/20.0	4.0	27/30	30/30
	RXBH-1724?07J	5.4/7.2	1/60	2-3.6	SINGLE	26.0/30.0	4.0	38/43	40/50
	RXBH-1724?10J	7.2/9.6	1/60	2-4.8	SINGLE	34.6/40.0	4.0	49/55	50/60
	RXBH-1724A15J	10.8/14.4	1/60	3-4.8	SINGLE	51.9/60.0	4.0	70/80	70/80
	RXBH-1724A15J	3.6/4.8	1/60	1-4.8	MULTIPLE CKT 1	17.3/20.0	4.0	27/30	30/30
		7.2/9.6	1/60	2-4.8	MULTIPLE CKT 2	34.6/40.0	0.0	44/50	50/50
	RXBH-1724A18J	12.8/17.0	1/60	3/5/68	SINGLE	61.6/70.8	4.0	82/94	90/100
	RXBJ-1724A18J	4.3/5.7	1/60	1/5/68	MULTIPLE CKT 1	20.5/23.6	4.0	31/35	40/40
		8.5/11.3	1/60	2/5/68	MULTIPLE CKT 2	41.1/47.2	0.0	52/59	60/60
	RXBH-24A20J	14.4/19.2	1/60	4-4.8	SINGLE	69.2/80	4.0	92/105	100/110
	RXBH-24A20J	7.2/9.6	1/60	2-4.8	MULTIPLE CKT 1	34.6/40.0	4.0	49/55	50/60
		7.2/9.6	1/60	2-4.8	MULTIPLE CKT 2	34.6/40.0	0.0	44/50	50/50
	RXBH-24A25J	18.0/24.0	1/60	6-4.0	SINGLE	86.4/99.9	4.0	113/130	120/130
	RXBH-24A25J	6.0/8.0	1/60	2-4.0	MULTIPLE CKT 1	28.8/33.3	4.0	41/47	50/50
		6.0/8.0	1/60	2-4.0	MULTIPLE CKT 2	28.8/33.3	0.0	36/42	40/50
		6.0/8.0	1/60	2-4.0	MULTIPLE CKT 3	28.8/33.3	0.0	36/42	40/50
	RXBH-1724A07C	5.4/7.2	3/60	3-2.4	SINGLE	15.0/17.3	4.0	24/27	30/30
	RXBH-1724A10C	7.2/9.6	3/60	3-3.2	SINGLE	20.0/23.1	4.0	30/34	30/40
	RXBH-1724A15C	10.8/14.4	3/60	3-4.8	SINGLE	30.0/34.6	4.0	43/49	50/50
	RXBH-1724A18C	12.8/17.0	3/60	3/5/68	SINGLE	35.6/41.0	4.0	50/57	50/60
	RXBH-24A20C	14.4/19.2	3/60	6-3.2	SINGLE	40.0/46.2	4.0	55/63	60/70
	RXBH-24A20C	7.2/9.6	3/60	3-3.2	MULTIPLE CKT 1	20.0/23.1	4.0	30/34	30/40
		7.2/9.6	3/60	3-3.2	MULTIPLE CKT 2	20.0/23.1	0.0	25/29	30/30
	RXBH-24A25C	18.0/24.0	3/60	6-4.0	SINGLE	50.0/57.8	4.0	68/78	70/80
	RXBH-24A25C	9.0/12.0	3/60	3-4.0	MULTIPLE CKT 1	25.0/28.9	4.0	37/42	40/50
		9.0/12.0	3/60	3-4.0	MULTIPLE CKT 2	25.0/28.9	0.0	32/37	40/40
	RXBH-24A07D	7.2	3/60	3-2.4	SINGLE	8.7	4.0	16/16	20/20
	RXBH-24A10D	9.6	3/60	3-3.2	SINGLE	11.6	4.0	20/20	20/20
	RXBH-24A15D	14.4	3/60	3-4.8	SINGLE	17.3	4.0	27/27	30/30
	RXBH-24A18D	17.0	3/60	6/2/84	SINGLE	20.4	4.0	31/31	40/40
	RXBH-24A20D	19.2	3/60	6-3.2	SINGLE	23.2	4.0	34/34	40/40
	RXBH-24A25D	24.0	3/60	6-4.0	SINGLE	28.8	4.0	41/41	50/50

Electrical Data–With Electric Heat FRH2TZ (Con't.)

Air Handler Model	Heater Model Number	Heater kW (208/240V)	Ph/Hz	No. Elements - kW per	Type Supply Circuit Single Circuit Multiple Circuit	Heater Amps.	Motor Amps	Minimum Circuit Ampacity	Maximum Overcurrent Protection
4824S 6021S 6024S	RXBH-1724?05J	3.6/4.8	1/60	1-4.8	SINGLE	17.3/20.0	4.7	28/31	30/40
	RXBH-1724?07J	5.4/7.2	1/60	2-3.6	SINGLE	26.0/30.0	4.7	39/44	40/50
	RXBH-1724?10J	7.2/9.6	1/60	2-4.8	SINGLE	34.6/40.0	4.7	50/56	50/60
	RXBH-1724A15J	10.8/14.4	1/60	3-4.8	SINGLE	51.9/60.0	4.7	71/81	80/90
	RXBH-1724A15J	3.6/4.8	1/60	1-4.8	MULTIPLE CKT 1	17.3/20.0	4.7	28/31	30/40
		7.2/9.6	1/60	2-4.8	MULTIPLE CKT 2	34.6/40.0	4.7	50/56	50/60
	RXBH-1724A18J	12.8/17	1/60	3/5/68	SINGLE	61.6/70.8	4.7	83/95	90/100
	RXBH-1724A18J	4.3/5.7	1/60	1/5/68	MULTIPLE CKT 1	20.5/23.6	4.7	32/36	40/40
		8.5/11.3	1/60	2/5/68	MULTIPLE CKT 2	41.1/47.2	0.0	52/59	60/60
	RXBH-24A20J	14.4/19.2	1/60	4-4.8	SINGLE	69.2/80	4.7	93/106	100/110
	RXBH-24A20J	7.2/9.6	1/60	2-4.8	MULTIPLE CKT 1	34.6/40.0	4.7	50/56	50/60
		7.2/9.6	1/60	2-4.8	MULTIPLE CKT 2	34.6/40.0	0.0	44/50	50/50
	RXBH-24A25J	18.0/24.0	1/60	6-4.0	SINGLE	86.4/99.9	4.7	114/131	120/140
	RXBH-24A25J	6.0/8.0	1/60	2-4.0	MULTIPLE CKT 1	28.8/33.3	4.7	42/48	50/50
		6.0/8.0	1/60	2-4.0	MULTIPLE CKT 2	28.8/33.3	0.0	36/42	40/50
		6.0/8.0	1/60	2-4.0	MULTIPLE	28.8/33.3	0.0	36/42	40/50
	RXBH-24A30J	21.6/28.8	1/60	6-4.8	SINGLE	103.8/120.	4.7	135/156	140/160
	RXBH-24A30J (6024S only)	7.2/9.6	1/60	2-4.8	MULTIPLE CKT 1	34.6/40.0	4.7	50/56	50/60
		7.2/9.6	1/60	2-4.8	MULTIPLE CKT 2	34.6/40.0	0.0	44/50	50/50
		7.2/9.6	1/60	2-4.8	MULTIPLE CKT 3	34.6/40.0	0.0	44/50	50/50
	RXBH-1724A07C	5.4/7.2	3/60	3-2.4	SINGLE	15.0/17.3	4.7	25/28	30/30
	RXBH-1724A10C	7.2/9.6	3/60	3-3.2	SINGLE	20.0/23.1	4.7	31/35	40/40
	RXBH-1724A15C	10.8/14.4	3/60	3-4.8	SINGLE	30.0/34.6	4.7	44/50	50/50
	RXBH-1724A18C	12.8/17.0	3/60	3/5/08	SINGLE	35.6/41.0	4.7	51/58	60/60
	RXBH-24A20C	14.4/19.2	3/60	6-3.2	SINGLE	40.0/46.2	4.7	56/64	60/70
	RXBH-24A20C	7.2/9.6	3/60	3-3.2	MULTIPLE CKT 1	20.0/23.1	4.7	31/35	40/40
		7.2/9.6	3/60	3-3.2	MULTIPLE CKT 2	20.0/23.1	0.0	25/29	30/30
	RXBH-24A25C	18.0/24.0	3/60	6-4.0	SINGLE	50.0/57.8	4.7	69/79	70/80
	RXBH-24A25C	9.0/12.0	3/60	3-4.0	MULTIPLE CKT 1	25.0/28.9	4.7	38/42	40/50
		9.0/12.0	3/60	3-4.0	MULTIPLE CKT 2	25.0/28.9	0.0	32/37	40/40
	RXBH-24A30C	21.6/28.8	3/60	6-4.8	SINGLE	60.0/69.4	4.7	81/93	90/100
	RXBH-24A30C (6024S only)	10.8/14.4	3/60	3-4.8	MULTIPLE CKT 1	30.0/34.7	4.7	44/50	50/50
10.8/14.4		3/60	3-4.8	MULTIPLE CKT 2	30.0/34.7	0.0	38/44	40/50	
4824S 6021S 6024S	RXBH-24A07D	7.2	3/60	3-2.4	SINGLE	8.7	5.6	18/18	20/20
	RXBH-24A10D	9.6	3/60	3-3.2	SINGLE	11.6	5.6	22/22	30/30
	RXBH-24A15D	14.4	3/60	3-4.8	SINGLE	17.3	5.6	29/29	30/30
	RXBH-24A18D	17.0	3/60	6/2/84	SINGLE	20.4	5.6	33/33	40/40
	RXBH-24A20D	19.2	3/60	6-3.2	SINGLE	23.2	5.6	36/36	40/40
	RXBH-24A25D	24.0	3/60	6-4.0	SINGLE	28.8	5.6	43/43	50/50
	RXBH-24A30D (6024S only)	28.8	3/60	6-4.8	SINGLE	34.6	5.6	51/51	60/60

Electrical Wiring

Power Wiring

- Field wiring must comply with the National Electrical Code (C.E.C. in Canada) and any applicable local ordinance.
- Supply wiring must be 75°C minimum copper conductors only.
- See electrical data for product Ampacity rating and Circuit Protector requirement.

Accessories

• Combustible Floor Base RXHB-

Model Cabinet Size	Combustible Floor Base Model Number
17	RXHB-17
21	RXHB-21
24	RXHB-24

- **Jumper Bar Kit 3 Ckt. to 1 Ckt. RXBJ-A31** is used to convert single phase multiple three circuit units to a single supply circuit. Kit includes cover and screw for line side terminals.
- **Jumper Bar Kit 2 Ckt. to 1 Ckt. RXBJ-A21** is used to convert single phase multiple two circuit units to a single supply circuit. Kit includes cover and screw for line side terminals.
- **Note:** No jumper bar kit is available to convert three phase multiple two circuit units to a single supply circuit.
- **Auxiliary Horizontal Overflow Pan Accessory RXBM-**

Nominal Cooling Capacity-Tons	Auxiliary Horizontal Overflow Pan Accessory Model Number
1 1/2 - 3	RXBM-AC48
3 1/2 - 5	RXBM-AC61

Grounding

- This product must be sufficiently grounded in accordance with National Electrical Code (C.E.C. in Canada) and any applicable local ordinance.
- A grounding lug is provided.

• Auxiliary Electric Heater Kits RXBH-

Heater Kits include circuit breakers which meet UL and cUL requirements for service disconnect. See the Electric Heat Electrical Data in this specification sheet for specific Heater Kit Model numbers.

• Horizontal Adapter Kit RXHH-

This horizontal adapter kit is used to convert Upflow/Downflow only models to horizontal flow. See the following table to order proper horizontal adapter kit.

Coil Model	Horizontal Adapter Kit Model Number (Single Qty.)	Horizontal Adapter Kit Model Number (10-Pack Qty.)
2414	RXHH-A01	RXHH-A01 x 10
2417	RXHH-A02	RXHH-A02 x 10
3617/3621	RXHH-A03	RXHH-A03 x 10
3821/4821/4824	RXHH-A04	RXHH-A04 x 10
3621HT/4821MT/6021ST	RXHH-06	RXHH-06 x 10
6024	RXHH-A05	RXHH-A05 x 10

• External Filter Base RXHF-

Model Cabinet Size	Filter Size In. [mm]	Part Number*	A	B
17	16 x 20 [406 x 508]	RXHF-17	15.70	17.5
21	20 x 20 [508 x 508]	RXHF-21	19.20	21.0
24	25 x 20 [635 x 508]	RXHF-24	22.70	25.5

*Accommodates 1" or 2" filter

[] Designates Metric Conversions

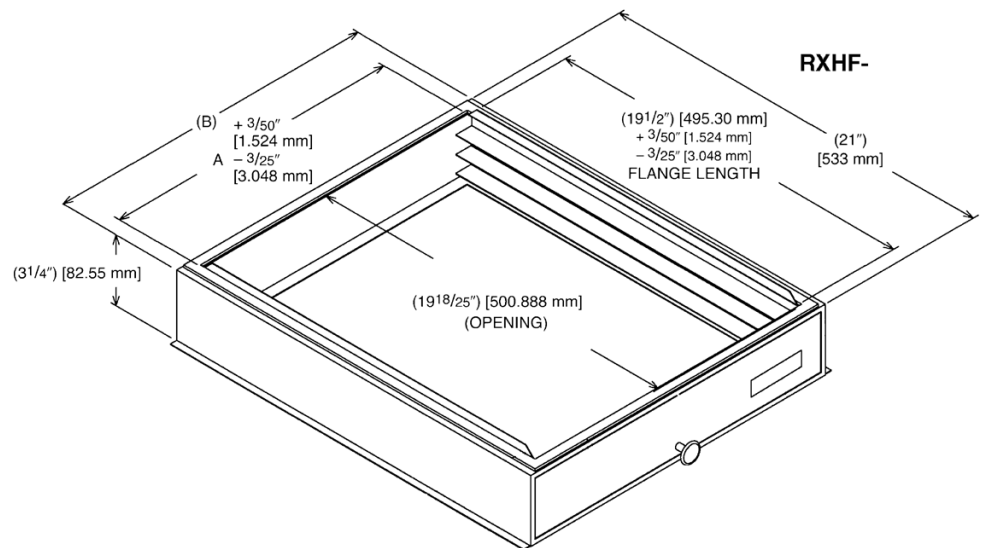
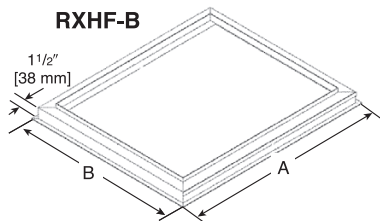



FRIEDRICH

1 8 8 3

GENERAL TERMS OF LIMITED WARRANTY*

Friedrich® will furnish a replacement for any part of this product which fails in normal use and service within the applicable periods stated, in accordance with the terms of the limited warranty.

Conditional Parts
(Registration Required)..... Ten (10) Years

***For complete details of the Limited and Conditional Warranties, including applicable terms and conditions, contact your local contractor or the Manufacturer for a copy of the product warranty certificate.**

Before proceeding with installation, refer to installation instructions packaged with each model, as well as complying with all Federal, State, Provincial, and Local codes, regulations, and practices.

© 2023 Rheem Manufacturing Company. Friedrich trademarks owned by Rheem Manufacturing Company.

In keeping with its policy of continuous progress and product improvement, Friedrich reserves the right to make changes without notice.

Friedrich • 5600 Old Greenwood Road
Fort Smith, Arkansas 72908 • www.friedrich.com

Friedrich • 125 Edgeware Road, Unit 1
Brampton, Ontario • L6Y 0P5