



# FLOATING AIR® PRO X | MULTI-ZONE | OUTDOOR HEAT PUMPS

OUTDOOR MODEL	Outdoor Model		FPHMR18A3D	FPHMR27A3D	FPHMR36A3D	FPHMR42A3D
	Power Supply	V/Hz/ph	208V/230V~, 60Hz,1P			
	ENERGY STAR® Standard*	Y/N	Y	Y	Y	Y
ENERGY STAR - Cold Climate*	Y/N	Y	Y	Y	Y	
COOLING	Rated Capacity @ 95°F	Btu/h	18,000	27,000	36,000	42,000
	Cooling Capacity Range (Min.-Max.)	Btu/h	9,000-22,000	9,000-31,000	9,000-46,800	9,000-54,600
	EER2 @ 95°F*	Btu/h/W	13.30	12.85	12.85	12.00
	SEER2*	Btu/h/W	22.00	23.00	22.00	22.00
	Cooling Operating Range (Min.-Max.)	°F	5-125	5-125	5-125	5-125
HEATING	Rated Capacity @ 47°F	Btu/h	18,000	27,000	36,000	42,000
	Heating Capacity Range (Min.-Max.)	Btu/h	9,000-30,000	9,000-44,000	9,000-54,000	9,000-58,000
	COP @ 47°F*	W/W	3.82	3.60	3.91	3.60
	COP @ 5°F*	W/W	1.99	1.82	1.92	1.92
	HSPF2*	Btu/h/W	10.0	10.0	10.0	9.50
	Rated Capacity Heating @ 17°F (-8.3°C)	Btu/h	11,500	17,600	22,600	28,200
	Maximum Heating Capacity @ 5°F (-15°C)	Btu/h	18,000	27,000	36,000	36,000
	Maximum Heating Capacity @ -13°F (-25°C)	Btu/h	13,356	19,177	26,175	27,216
Heating Operating Range (Min.-Max.)	°F	-13-75	-13-75	-13-75	-13-75	
AIRFLOW	Air Circulation (High) for Outdoor	ft³ CFM	1,850	3,357	3,357	3,357
	Sound Rating - Outdoor	dB(A)	55	62	64	64
FAN MOTOR	Output	W	60	220	220	220
	Speed (High)	r/min	880	850	830	830
ELECTRICAL	Rated Current	Cooling (A)	6.3	9.3	12.8	15.5
		Cooling (W)	1,350	2,100	2,802	3,500
		Heating (A)	6.4	10.0	12.5	18.0
		Heating (W)	1,380	2,200	2,700	3,910
	MOP (Rating of Overcurrent Protective Device)	A	25.0	30.0	35.0	40.0
	MCA (Minimum Circuit Ampacity)	A	21.0	25.0	32.0	36.0
Communication Wire Size and Type		4 × 14AWG	4 × 14AWG	4 × 14AWG	4 × 14AWG	
REFRIGERATION (R-454B)	Moisture Removal	pints/hr	2.4	3.0	4.3	4.35
	Refrigerant Charge Volume	oz.	51.1	76.2	105.8	105.8
	Liquid Pipe	in.	1/4	1/4	1/4	1/4
	Gas Pipe	in.	3/8	3/8	3/8	3/8
	Connection		Flare	Flare	Flare	Flare
	Max. Pipe Length (Total)	ft.	164.0	230.0	230.0	262.0
	Max. Elevation (Indoor Units Higher Than Outdoor Unit)	ft.	49.0	49.0	49.0	49.0
	Pre-charge Pipe Length	ft.	50.0	75.0	100.0	125.0
Additional Refrigerant Charge per Foot After 25 ft.	oz./ft.	0.16	0.16	0.16	0.16	
DIMENSIONS & WEIGHTS	Dimension (W×H×D)	in.	33-7/8×26-3/8×12-1/4	38-3/8×32-7/8×14-1/8	38-3/8×32-7/8×14-1/8	38-3/8×32-7/8×14-1/8
		mm	860×670×310	975×835×360	975×835×360	975×835×360
	Packing (L×W×H)	in.	39-17-3/4×28-3/4	43-3/4×18-1/8×37-3/4	43-3/4×18-1/8×37-3/4	43-3/4×18-1/8×37-3/4
		mm	990×450×730	1,111×460×960	1,111×460×960	1,111×460×960
	Net Weight	lbs.	101.4	160.6	169.8	172.0
		kg	46.0	72.9	77.0	78.0
Shipping Weight	lbs.	112.4	183.2	191.8	194	
	kg	51.0	83.1	87.0	88.0	

## MULTI-ZONE CONFIGURATION, AHRI RATINGS

Friedrich Model	AHRI Reference Number	Indoor Type	System Cooling 95°F Capacity	EER2	SEER2	High Heat 47°F	HSPF2	Low Heat 17°F	COP 5°F	Maximum Heating Capacity -13°F
FPHMR18A3D	215792836	Non-Ducted Indoor Units	18,000	13.30	22	18,000	10	11,500	1.99	13,356
	215792837	Ducted Indoor Units	18,000	12.00	17.5	18,000	9.4	11,900	1.96	13,356
	215792838	Mixed Ducted and Non-Ducted Indoor Units	18,000	12.65	19.75	18,000	9.7	11,700	1.96	13,356
FPHMR27A3D	215792839	Non-Ducted Indoor Units	27,000	12.85	23	27,000	10	17,600	1.82	19,177
	215792840	Ducted Indoor Units	27,000	11.50	18	27,000	8.8	18,200	1.84	19,177
	215792841	Mixed Ducted and Non-Ducted Indoor Units	27,000	12.20	20.5	27,000	9.4	18,000	1.82	19,177
FPHMR36A3D	215792846	Non-Ducted Indoor Units	36,000	12.85	22	36,000	10	22,600	1.92	26,175
	215792845	Ducted Indoor Units	36,000	12.85	19	36,000	9	21,000	1.83	26,175
	215792847	Mixed Ducted and Non-Ducted Indoor Units	36,000	12.85	20.5	36,000	9.5	21,800	1.87	26,175
FPHMR42A3D	215792843	Non-Ducted Indoor Units	42,000	12.00	22	48,000	9.5	28,200	1.92	27,216
	215792842	Ducted Indoor Units	42,000	11.35	18	45,000	8.8	27,400	1.83	27,216
	215792844	Mixed Ducted and Non-Ducted Indoor Units	42,000	11.80	20	46,500	9.15	27,800	1.87	27,216









Due to continuing research in new energy-savings technology, specifications are subject to change without notice.



## FLOATING AIR® PRO X | MULTI-ZONE | INDOOR OPTIONS

### Multi-Zone Wall-Mounted Key Features

 Indicates sustainability feature

-  **FastPro®** design for the fastest access for maintenance of any wall-mounted ductless systems
-  All models ENERGY STAR® and ENERGY STAR® Cold Climate Heat Pump certified
-  **Precision Inverter®** technology (variable speed compressor)
-  Soft-Start™ compressor
-  BLDC motor
-  Built-in Wi-Fi
-  Sleep mode
-  Easy-to-read temperature display
-  Wireless remote control included



### FEATURING OUR **FastPro®** DESIGN



FAHMM07A3D, FAHFW09A3D, FAHFW12A3D,  
FAHFW18A3D, FAHFW24A3D

## FLOATING AIR® PRO X | MULTI-ZONE | WALL-MOUNTED

MODEL	Indoor Model	Unit	FAHMM07A3D	FAHFW09A3D	FAHFW12A3D	FAHFW18A3D	FAHFW24A3D
		Power Supply	V/ph/Hz	208V/230V~,60Hz,1P			
COOLING	Rated Capacity @ 95°F	Btu/h	7,000	9,000	12,000	18,000	24,000
	Cooling Capacity Range (Min.-Max.)	Btu/h	3,600-10,000	4,600-12,700	4,600-12,700	7,800-22,000	10,000-28,000
HEATING	Rated Capacity @ 47°F	Btu/h	8,500	9,000	12,000	18,000	24,000
	Heating Capacity Range (Min.-Max.)	Btu/h	3,600-10,000	5,500-16,000	5,500-16,000	7,800-23,000	6,700-30,000
AIRFLOW	Air Circulation (Max./H/M/L)	ft³ CFM	382/341/294/247	382/341/294/247	394/365/312/253	647/588/482/382	706/647/559/441
	Sound Rating - Indoor (Max./H/M/L/Quiet)	dB(A)	42/39/37/35/32	42/39/37/35/32	42/39/37/35/32	48/45/41/39/36	50/48/43/41/39
FAN MOTOR	Output	W	25	25	25	35	35
	Speed (High/Med/Low)	r/min	1,101/938/800	1,100/938/800	1,154/992/800	1,100/960/800	1,200/1,040/880
DIMENSIONS & WEIGHTS	Dimension (W×H×D)	in.	33-7/8×11-2/8×8-4/8	33-7/8×11-2/8×8-4/8	33-7/8×11-2/8×8-4/8	45-2/8×13-2/8×10-1/8	45-2/8×13-2/8×10-1/8
		mm	860×285×216	860×285×216	860×285×216	1,148×336×256	1,148×336×256
	Packing (L×H×W)	in.	36-5/8×15×11-2/8	36-5/8×15×11-2/8	36-5/8×15×11-2/8	47-7/8×16-1/8×13	47-7/8×16-1/8×13
		mm	930×380×285	930×380×285	930×380×285	1,215×410×330	1,215×410×330
	Net Weight	lbs.	22.1	22.1	22.1	34.2	34.2
		kg	10.0	10.0	10.0	15.5	15.5
	Shipping Weight	lbs.	26.5	26.5	26.5	39.7	39.7
		kg	12.0	12.0	12.0	18.0	18.0



Due to continuing research in new energy-savings technology, specifications are subject to change without notice.







# FLOATING AIR® PRO X | MULTI-ZONE | INDOOR OPTIONS

## Multi-Zone Ceiling Cassette Key Features

 Indicates sustainability feature

-  All models ENERGY STAR® and ENERGY STAR® Cold Climate Heat Pump certified
-  Precision Inverter® technology (variable speed compressor)

-  Soft-Start™ compressor
-  BLDC motor
-  Built-in Wi-Fi
-  Sleep mode
- 3 fan speeds
- Ultra-quiet turbo fan

- Precise 4-way air distribution
- Evaporator frost control
- Built-in drain lift
- Flexible installation
- Clean, modern look
- Wireless remote control included



FPFC09A3D, FPFC12A3D



FPFC18A3D, FPFC24A3D,  
FPFC36A3D



FPCG0912A



FPCG182436A

DECORATIVE GRILLE	
FPCG0912A	FPCG182436A
FITS FPFC09A3D, FPFC12A3D	FITS FPFC18A3D, FPFC24A3D, FPFC36A3D

## FLOATING AIR® PRO X | MULTI-ZONE | CEILING CASSETTE

MODEL	Indoor Model	Unit	FPFC09A3D	FPFC12A3D	FPFC18A3D	FPFC24A3D
	Power Supply		V/ph/Hz	208V/230V~, 60Hz, 1P		
COOLING	Rated Capacity @ 95°F	Btu/h	9,000	12,000	18,000	24,000
	Cooling Capacity Range (Min.-Max.)	Btu/h	4,300-14,500	4,300-14,500	7,800-24,000	9,000-30,000
HEATING	Rated Capacity @ 47°F	Btu/h	9,000	12,000	18,000	24,000
	Heating Capacity Range (Min.-Max.)	Btu/h	5,500-18,000	5,500-18,000	8,500-24,000	7,500-34,000
AIRFLOW	Air Circulation (H/M/L)	ft³ CFM	341/341/294/235	341/341/294/235	643/643/554/465	706/706/588/494
	Sound Rating - Indoor (H/M/L)	dB(A)	52	52	50	53
FAN MOTOR	Output	W	57	57	75	75
	Speed (High/Med/Low)	r/min	700/600/500	700/600/500	420/380/320	470/400/340
DIMENSIONS & WEIGHTS	Dimension (W×H×D)	in.	22-1/2×8-1/2×22-1/2	22-1/2×8-1/2×22-1/2	33-1/8×9-1/4×33-1/8	33-1/8×9-1/4×33-1/8
		mm	570×215×570	570×215×570	840×236×840	840×236×840
	Packing (L×W×H)	in.	28-3/4×26-1/4×11-1/2	28-3/4×26-1/4×11-1/2	37-3/8×12-5/8×37-3/8	37-3/8×12-5/8×37-3/8
		mm	730×668×292	730×668×292	950×950×320	950×950×320
	Net Weight	lbs.	34.2	34.2	52.9	52.9
		kg	15.5	15.5	24.0	24.0
Shipping Weight	lbs.	40.8	40.8	63.9	63.9	
	kg	18.5	18.5	29.0	29.0	
INDOOR GRILLE	Dimension (W×H×D)	in.	24-3/8×1-5/8×24-3/8	24-3/8×1-5/8×24-3/8	37-3/8×2×37-3/8	37-3/8×2×37-3/8
		mm	620×40×620	620×40×620	950×50×950	950×50×950
	Packing (L×W×H)	in.	27-1/8×26-3/4×4-1/2	27-1/8×26-3/4×4-1/2	40-1/8×39-3/8×4-1/8	40-1/8×39-3/8×4-1/8
		mm	690×680×115	690×680×115	1,020×1,000×105	1,020×1,000×105
	Net Weight	lbs.	5.7	5.7	14.3	14.3
		kg	2.6	2.6	6.5	6.5
Shipping Weight	lbs.	9.9	9.9	19.8	19.8	
	kg	4.5	4.5	9.0	9.0	

Due to continuing research in new energy-savings technology, specifications are subject to change without notice.

Standard







With Registration











## FLOATING AIR® PRO X | MULTI-ZONE | INDOOR OPTIONS

### Multi-Zone The Insider® Concealed Ducted Key Features

 Indicates sustainability feature

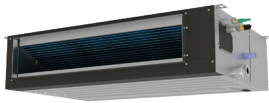
-  Precision Inverter® technology (variable speed compressor)
-  Soft-Start™ compressor
-  BLDC motor
-  All ENERGY STAR® certified models
-  All ENERGY STAR® Cold-Climate Heat Pump certified models
- Wall Controller included (FPWC1)
- Control lock function on controller
- External static pressure range 9K/12K/18K/24K 0-.40WC (Multi-Zone)



FPHFD09A3D, FPHFD12A3D, FPHFD18A3D, FPHFD24A3D, FPHSD36A3D



FPWC1

## FLOATING AIR® PRO X | MULTI-ZONE | THE INSIDER® CONCEALED DUCTED

MODEL	Indoor Model	Unit	FPHFD09A3D	FPHFD12A3D	FPHFD18A3D	FPHFD24A3D
		Power Supply	V/ph/Hz	208V/230V~, 60Hz, 1P		
COOLING	Rated Capacity @ 95°F	Btu/h	9,000	12,000	18,000	24,000
	Cooling Capacity Range (Min.-Max.)	Btu/h	4,300-14,500	4,300-14,500	6,500-25,000	9,000-31,500
HEATING	Rated Capacity @ 47°F	Btu/h	9,000	12,000	18,000	24,000
	Heating Capacity Range (Min.-Max.)	Btu/h	5,300-18,000	5,300-18,000	5,700-30,000	7,600-37,500
AIRFLOW	Air Circulation (H/M/L)	ft³ CFM	324/324/294/235	324/324/294/235	530/530/471/412	735/735/647/559
	Sound Rating - Indoor (H/M/L)	dB(A)	57	57	60	68
	ESP (in H <sub>2</sub> O)	Rated with filter	0.18	0.18	0.18	0.58
		Rated with filter	0-0.12	0-0.12	0-0.56	0-0.66
FAN MOTOR	Output	W	57	57	75	75
	Speed (High/Med/Low)	r/min	1,110/1,000/800	1,110/1,000/800	920/820/720	1,400/1,250/1,100
DIMENSIONS & WEIGHTS	Dimension (W×H×D)	in.	35-7/8×7-1/2×17-5/8	35-7/8×7-1/2×17-5/8	31-1/2×9-5/8×27-1/2	43-1/4×9-5/8×27-1/2
		mm	910×190×447	910×190×447	800×245×700	1,100×245×700
	Packing (L×W×H)	in.	42-1/2×22-1/4×11-1/4	42-1/2×22-1/4×11-1/4	38-5/8×12-3/8×31-7/8	50-3/8×12-3/8×31-7/8
		mm	1,080×565×285	1,080×565×285	980×315×810	1,280×315×810
	Net Weight	lbs.	44.1	44.1	58.4	73.9
		kg	20.0	20.0	26.5	33.5
	Shipping Weight	lbs.	51.8	51.8	58.4	73.9
		kg	23.5	23.5	31.0	38.5





Due to continuing research in new energy-savings technology, specifications are subject to change without notice.



## FLOATING AIR® PRO X | MULTI-ZONE | INDOOR OPTIONS

### Multi-Zone Air Handler Key Features

 Indicates sustainability feature

-  All models ENERGY STAR® and ENERGY STAR® Cold-Climate Heat Pump certified
-  Precision Inverter® technology (variable speed compressor)
-  Soft-Start™ compressor
-  BLDC motor
- Air handler can be installed in 4 configurations; upflow, downflow, horizontal left and horizontal right
- Aluminum indoor coil
- 3 fan speeds
- Compatible with 24V thermostats
- Efficiencies of up to 19.0 SEER2



FPHFA18A3D, FPHFA24A3D

## FLOATING AIR® PRO X | MULTI-ZONE | AIR HANDLER

MODEL	Indoor Model	Unit	FPHFA18A3D	FPHFA24A3D
	Power Supply	V/ph/Hz	208V/230V~, 60Hz, 1P	
COOLING	Rated Capacity @ 95°F	Btu/h	18,000	24,000
	Cooling Capacity Range (Min.–Max.)	Btu/h	10,500–31,000	10,500–31,000
HEATING	Rated Capacity @ 47°F	Btu/h	18,000	24,000
	Heating Capacity Range (Min.–Max.)	Btu/h	11,700–33,000	11,700–33,000
AIRFLOW	Rated Airflow	ft³ CFM	800	800
	Min.–Max.	ft³ CFM	529–823	529–823
	Sound Rating – Indoor (High)	dB(A)	51	51
FAN MOTOR	Output	W	373	373
	RLA	A	2.6	2.6
	Speed (High/Low)	r/min	350–1,400	350–1,400
DIMENSIONS & WEIGHTS	Dimension (W×H×D)	in.	17-4/8×45×21	17-4/8×45×21
		mm	445×1,143×534	445×1,143×534
	Packing (L×H×W)	in.	20-4/8×25-2/8×49-6/8	20-4/8×25-2/8×49-6/8
		mm	520×1,265×640	520×1,265×640
	Net Weight	lbs.	130.5	130.5
		kg	59.2	59.2
	Shipping Weight	lbs.	153.6	153.6
		kg	69.7	69.7

Due to continuing research in new energy-savings technology, specifications are subject to change without notice.



## ACCESSORIES



**FPWC1** – Optional hard-wired controller for Floating Air wall-mounted and cassette indoor models. Included with concealed ducted models. Not compatible with AHU indoor models. See your Friedrich representative for options.



**FreshAir Purifier APWM1 by iWave®** – Optional accessory for all wall-mounted ductless models that kills mold, bacteria and viruses—while effectively removing odors and VOCs.



**DSSXEMWRTA4** – Optional wireless energy management thermostat with occupancy sensor. For Floating Air Pro, single- and multi-zone models. See your Friedrich representative for options.



**ADS01** – Field-installed A2L sensor for Floating Air R-454B wall-mounted applications.

**ADS02** – Field-installed A2L sensor for Floating Air R-32 wall-mounted applications. See Installation and Operational Manual for additional information & requirements.

## REFRIGERATION LINE SETS OUTSIDE DIMENSIONS & MIN./MAX. LENGTHS

System Model	Liquid	Suction	Lineset Kit	Lineset Kit	Min. (Ft.)	Max. EA./Total (Ft.)
FPHMR18A3D	1/4	3/8	T32150 - 15'	T32350 - 35'	25	82/164
FPHMR27A3D	1/4	3/8	T32150 - 15'	T32350 - 35'	25	66/230
FPHMR36A3D	1/4	3/8	T32150 - 15'	T32350 - 35'	25	66/230
FPHMR42A3D	1/4	3/8	T32150 - 15'	T32350 - 35'	25	66/230

# DIMENSIONAL DRAWINGS: OUTDOOR HEAT PUMP

## OUTDOOR UNITS/ FPHMR18A3D

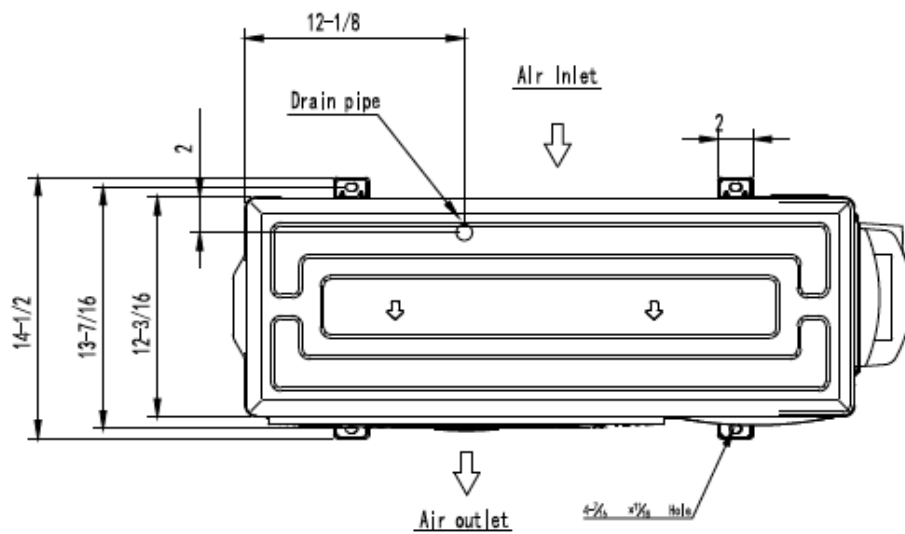
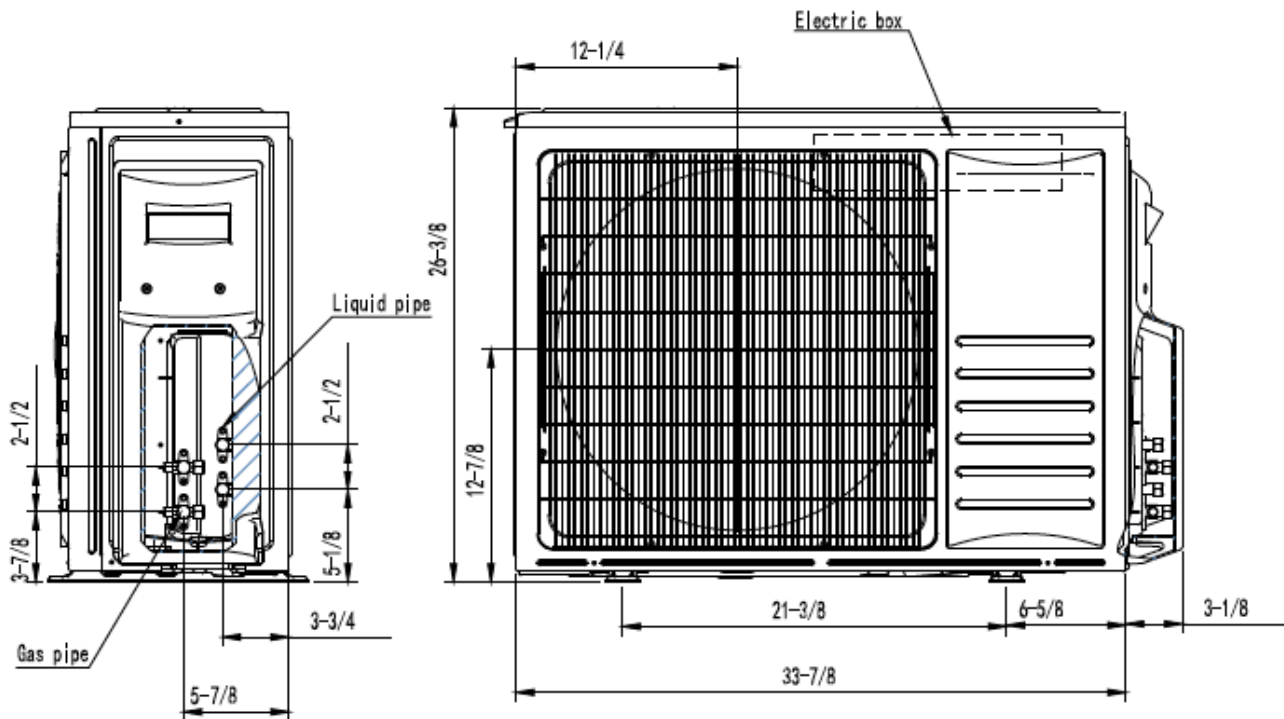

Model	W	H	D
<b>FPHMR18A3D</b>	33 7/8"	26 3/8"	12 3/16"

UNITS: INCHES

# DIMENSIONAL DRAWINGS: OUTDOOR HEAT PUMP

OUTDOOR UNITS/ FPHMR27A3D, FPHMR36A3D, FPHMR42A3D

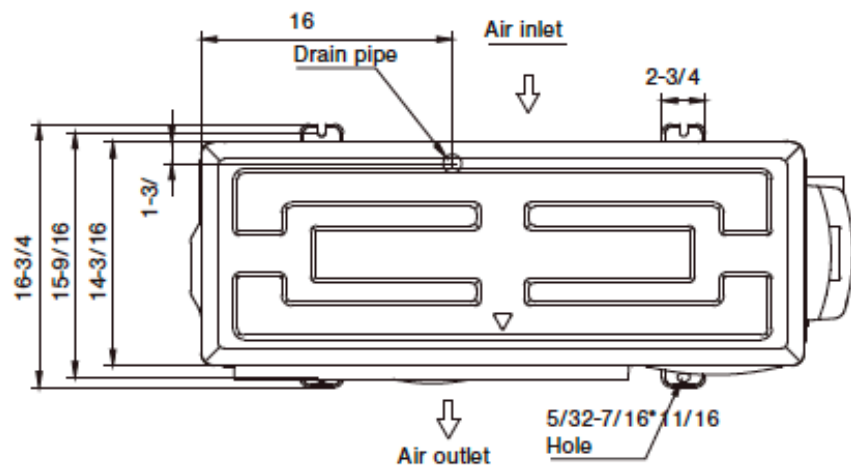
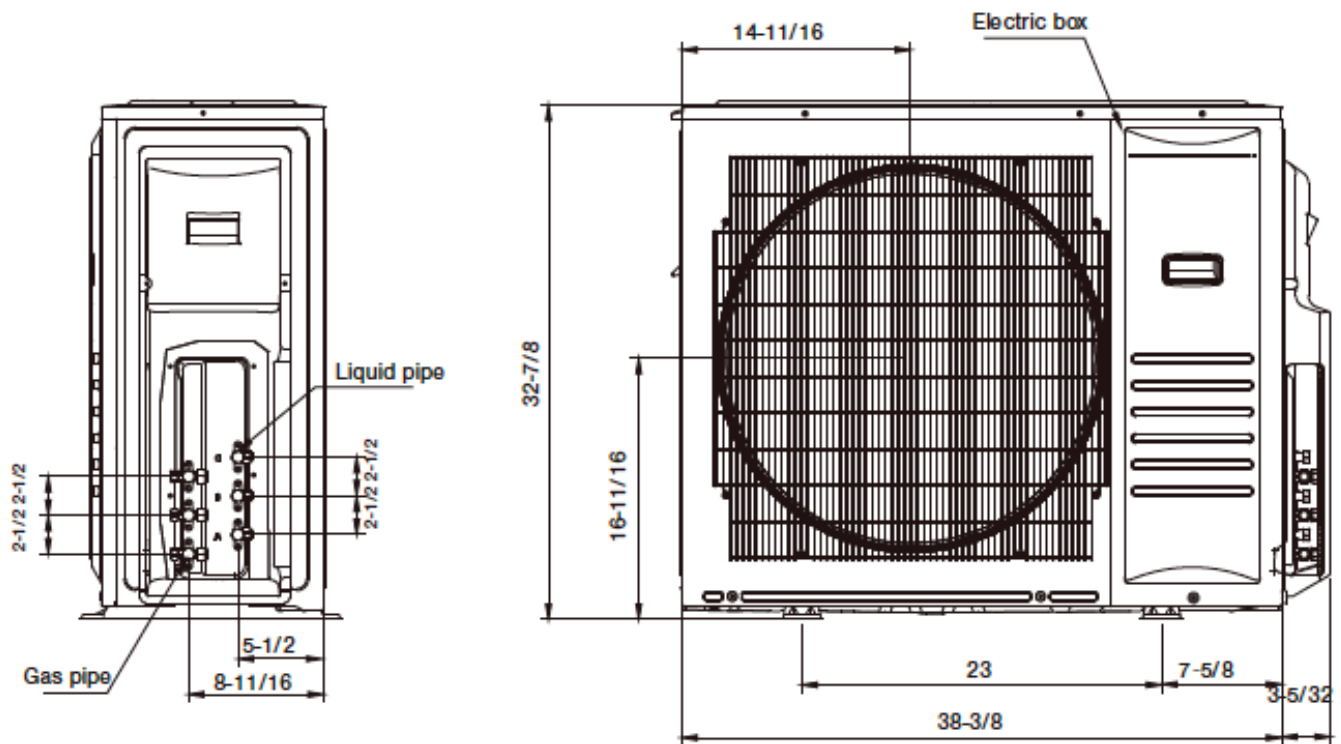

Model	W	H	D
FPHMR27A3D, FPHMR36A3D, FPHMR42A3D	38 3/8"	32 7/8"	14 3/16"

UNITS: INCHES

# DIMENSIONAL DRAWINGS: WALL-MOUNTED

INDOOR UNITS/ FAHMW07A3D, FAHFW09A3D, FAHFW12A3D

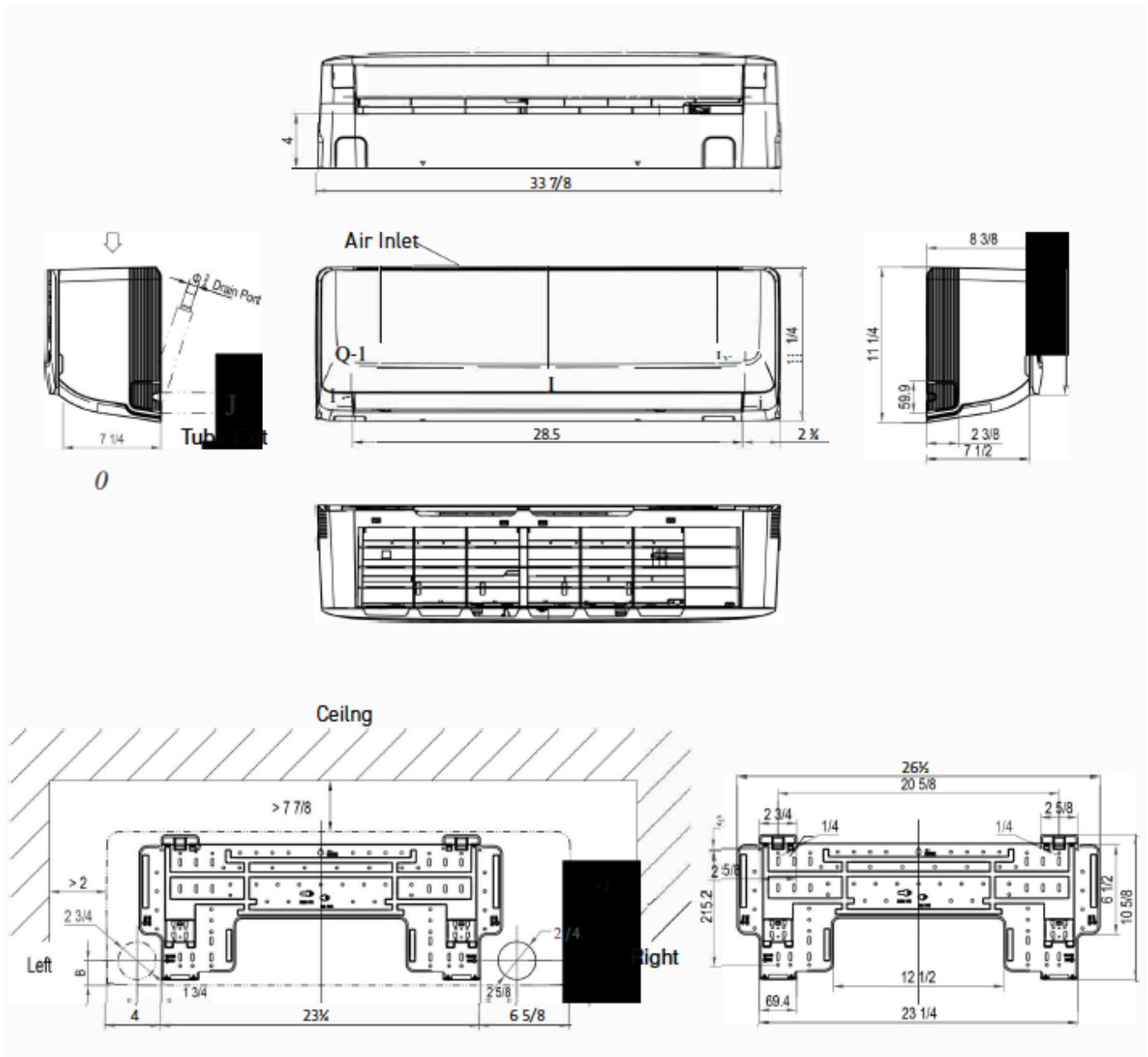

Model	W	H	D
FAHMW07A3D, FAHFW09A3D, FAHFW12A3D	$33 \frac{7}{8}$ "	$8 \frac{3}{8}$ "	$11 \frac{1}{4}$ "

UNITS: INCHES

# DIMENSIONAL DRAWINGS: WALL-MOUNTED

INDOOR UNITS/ FAHFW18A3D, FAHFW24A3D

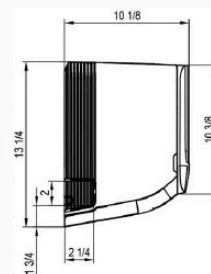
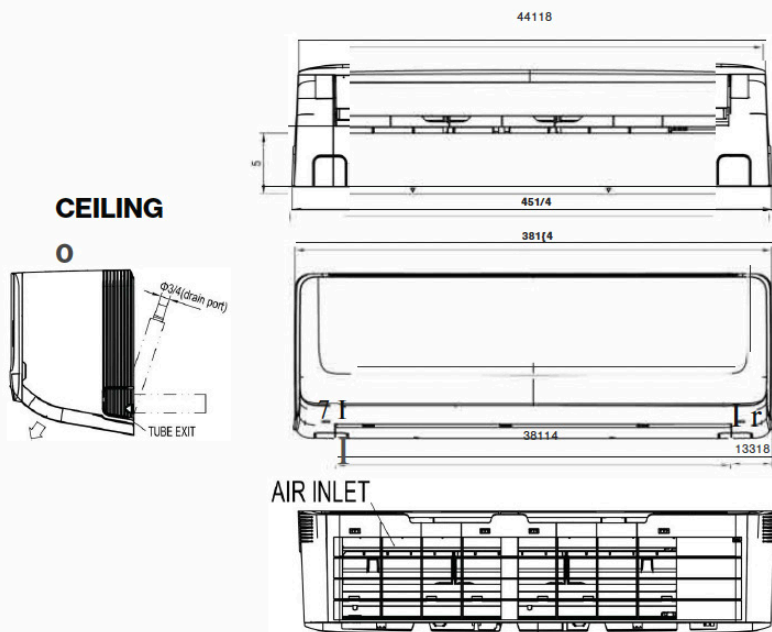

23718  
27314  
37112

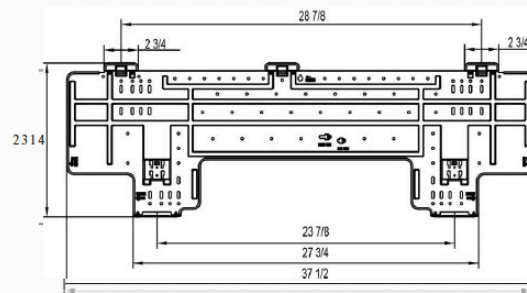
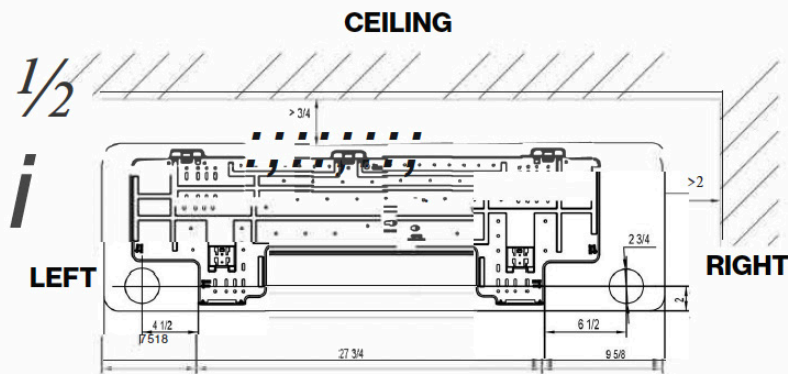

Model	W	H	D
FAHFW18A3D, FAHFW24A3D	45 1/4"	10 1/8"	13 1/4"

UNITS: INCHES

# DIMENSIONAL DRAWINGS: CEILING CASSETTE

INDOOR UNITS/ FPHFC09A3D, FPHFC12A3D

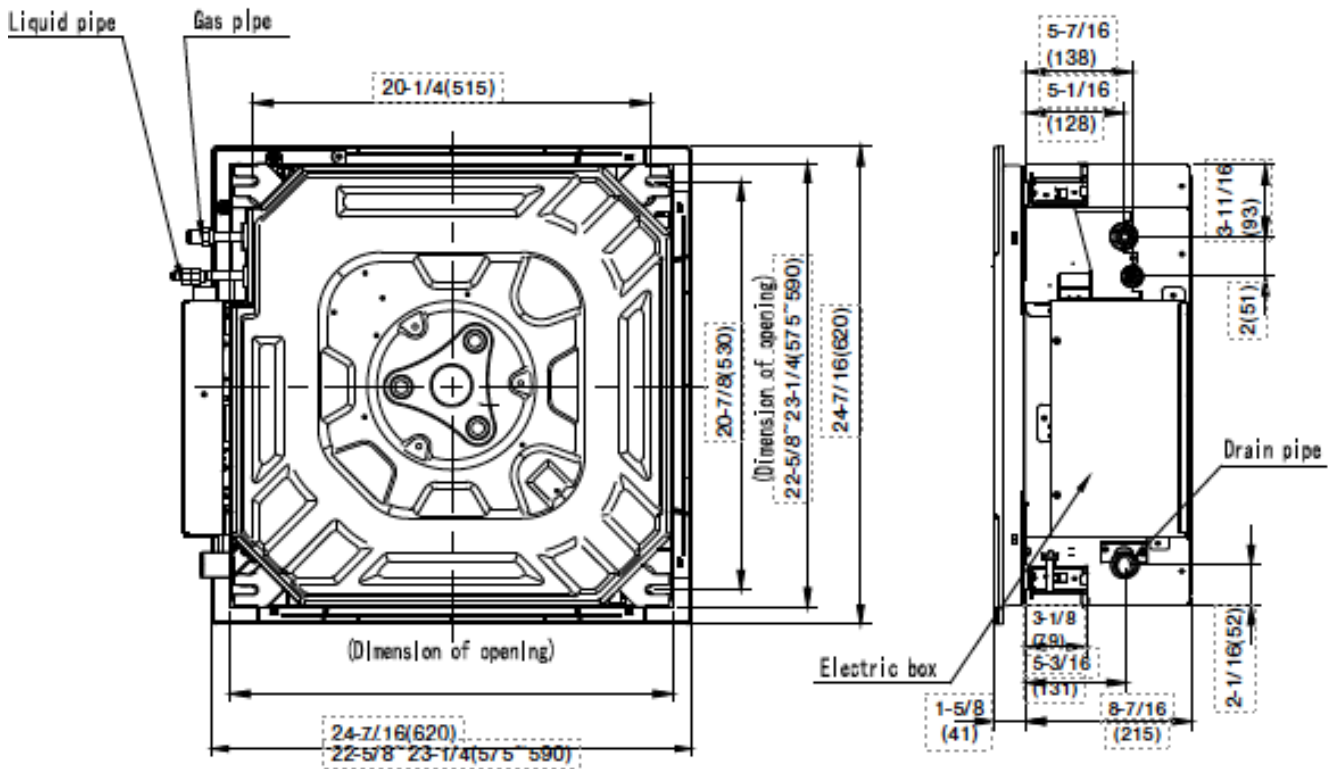
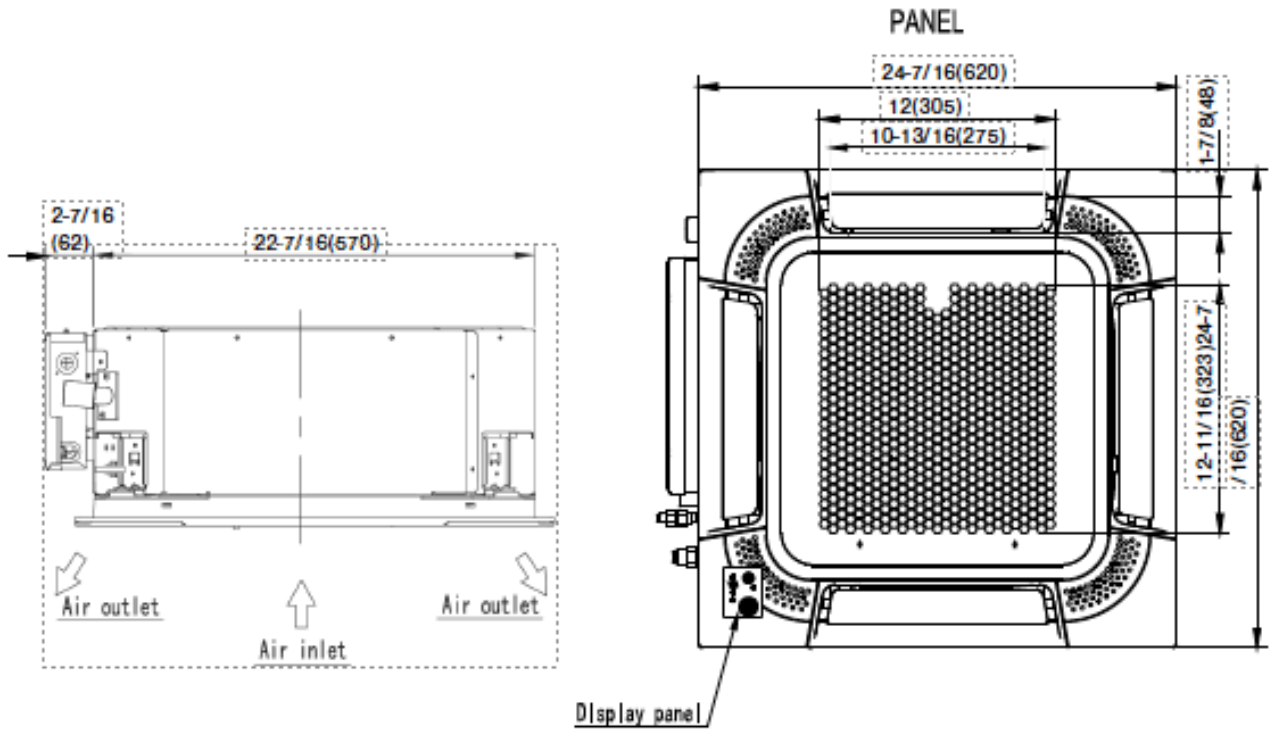

Model	W	H	D
FPHFC09A3D, FPHFC12A3D	24 7/16"	24 7/16"	8 7/16"

UNITS: INCHES

# DIMENSIONAL DRAWINGS: CEILING CASSETTE

INDOOR UNITS/ FPHFC18A3D, FPHFC24A3D, FPHSC36A3D

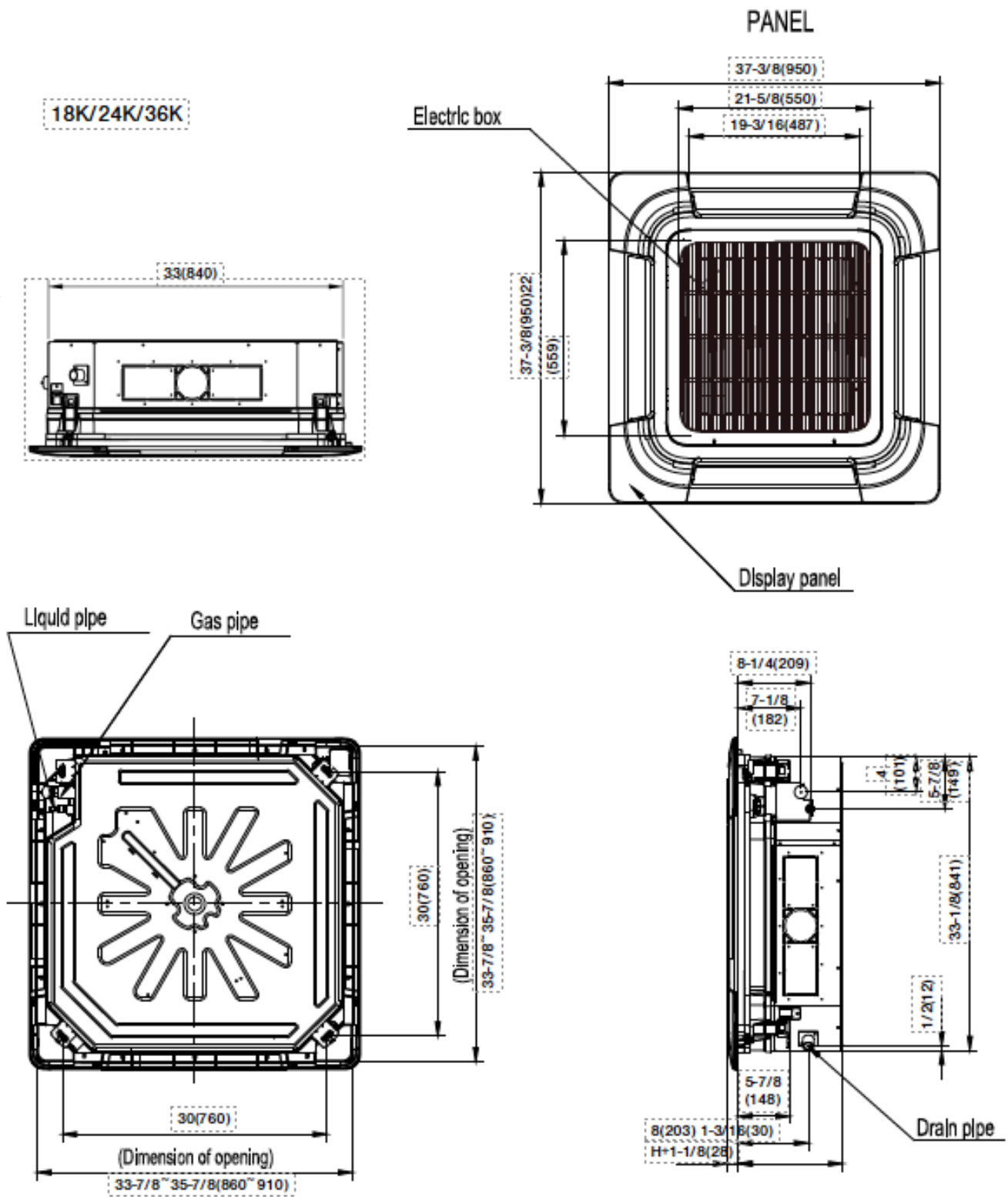

Model	W	H	D
FPHFC18A3D, FPHFC24A3D, FPHSC36A3D	24 7/16"	24 7/16"	8 7/16"

UNITS: INCHES

# DIMENSIONAL DRAWINGS: CONCEALED DUCTED

INDOOR UNITS/ FPHFD09A3D, FPHFD12A3D

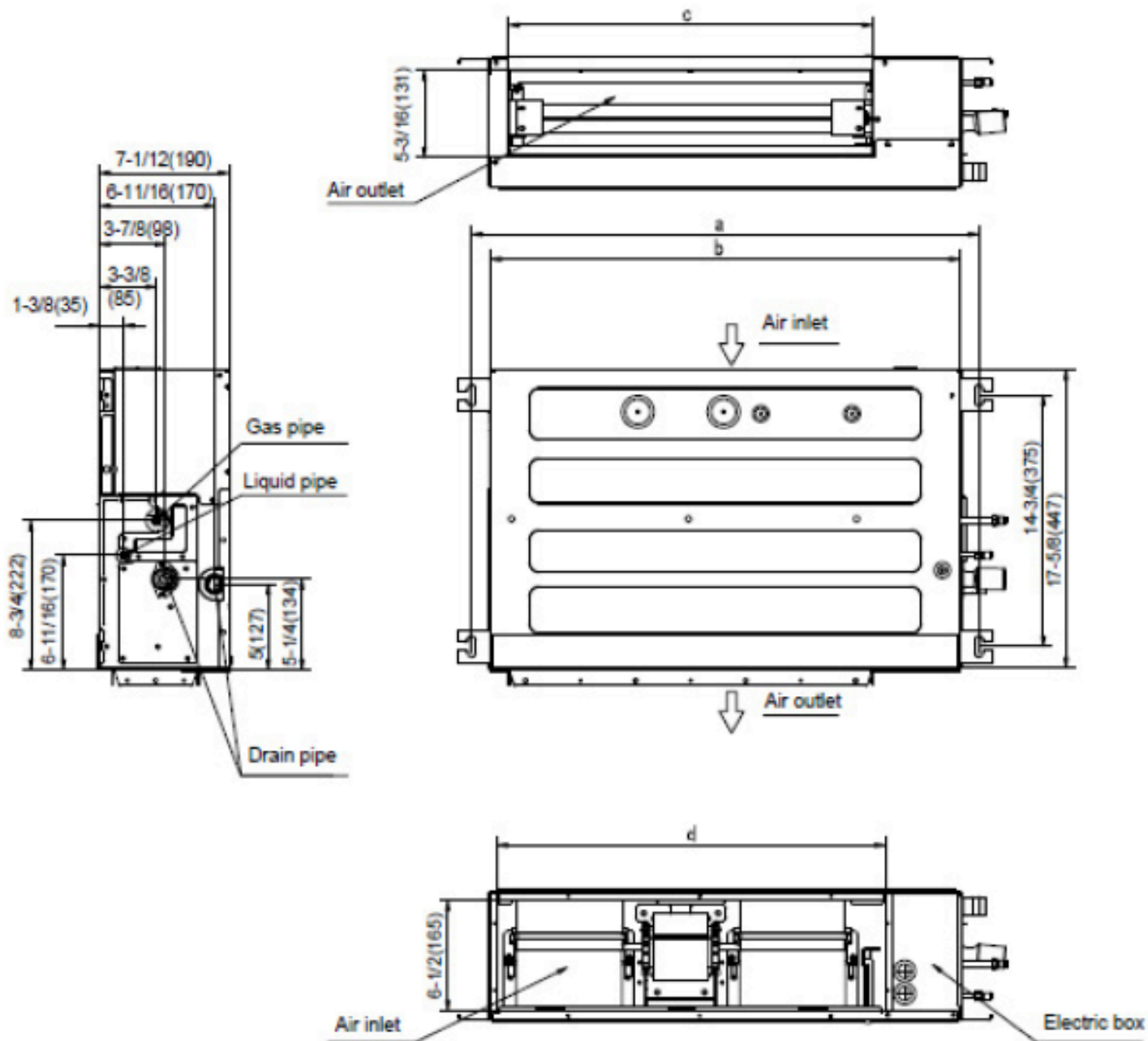

UNITS: INCHES (MM)

Model (Btu/h)	a	b	c	d
9K/12K	37-13/16 (961)	35-13/16 (910)	29-1/2 (749)	30 (786)

# DIMENSIONAL DRAWINGS: CONCEALED DUCTED

INDOOR UNITS/ FPHFD18A3D, FPHFD24A3D

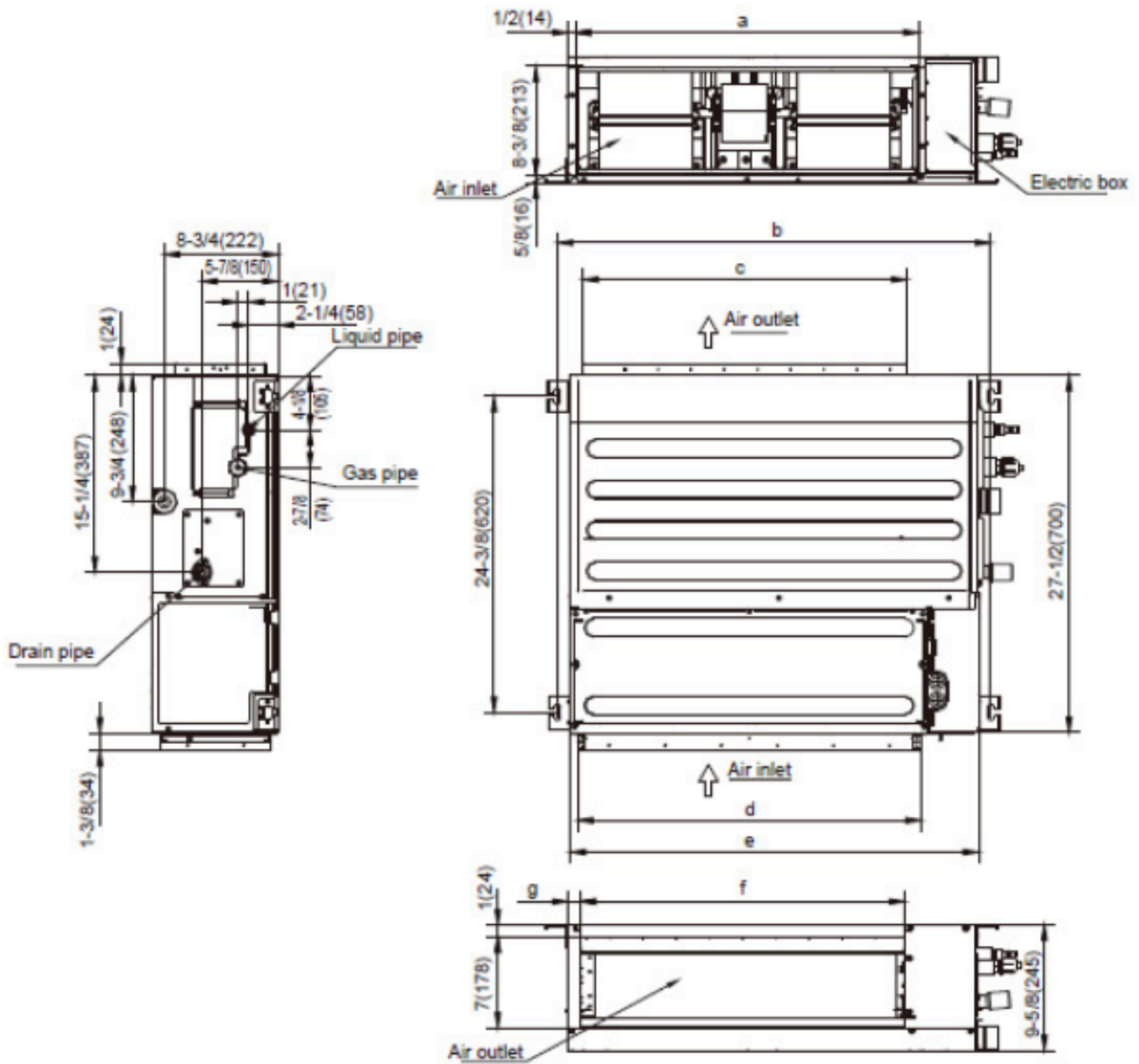

UNITS: INCHES (MM)

Model (Btu/h)	a	b	c	d	e	f	g
18K	26-1/2 (674)	33-1/2 (850)	25 (636)	26-1/2 (673)	31-1/2 (800)	25 (636)	1 (24)
24K	38-3/4 (974)	45-1/4 (1,150)	35-7/8 (912)	38-1/4 (973)	43-1/4 (973)	35-7/8 (912)	1-7/8 (49)

# DIMENSIONAL DRAWINGS: CONCEALED DUCTED

## INDOOR UNITS/ FPHSD36A3D

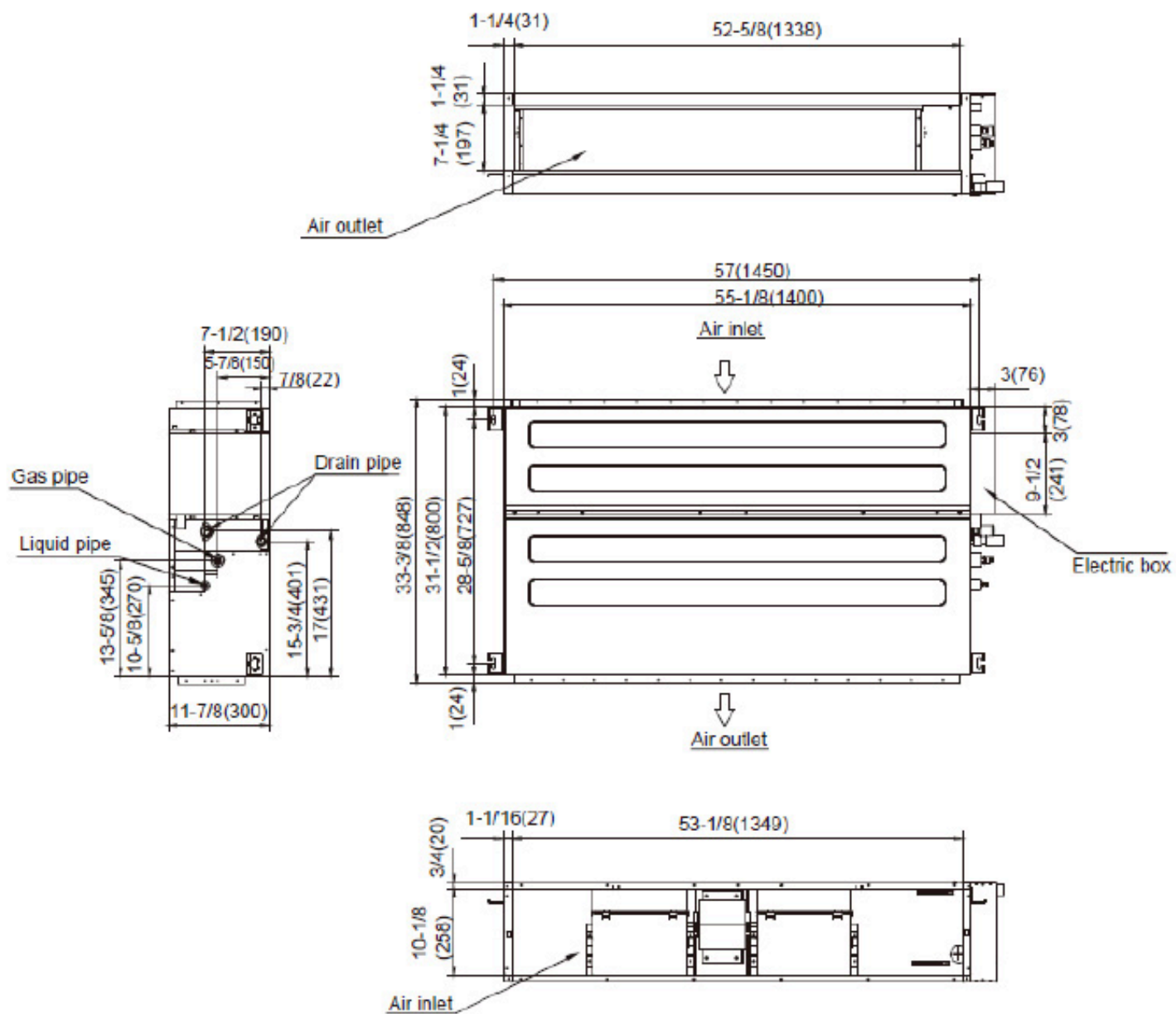

Model	W	H	D
<b>FPHSD36A3D</b>	52 5/8"	33 3/8"	11 7/8"

UNITS: INCHES

# DIMENSIONAL DRAWINGS: AIR HANDLER

INDOOR UNITS/ FPHFA18A3D, FPHFA23A3D

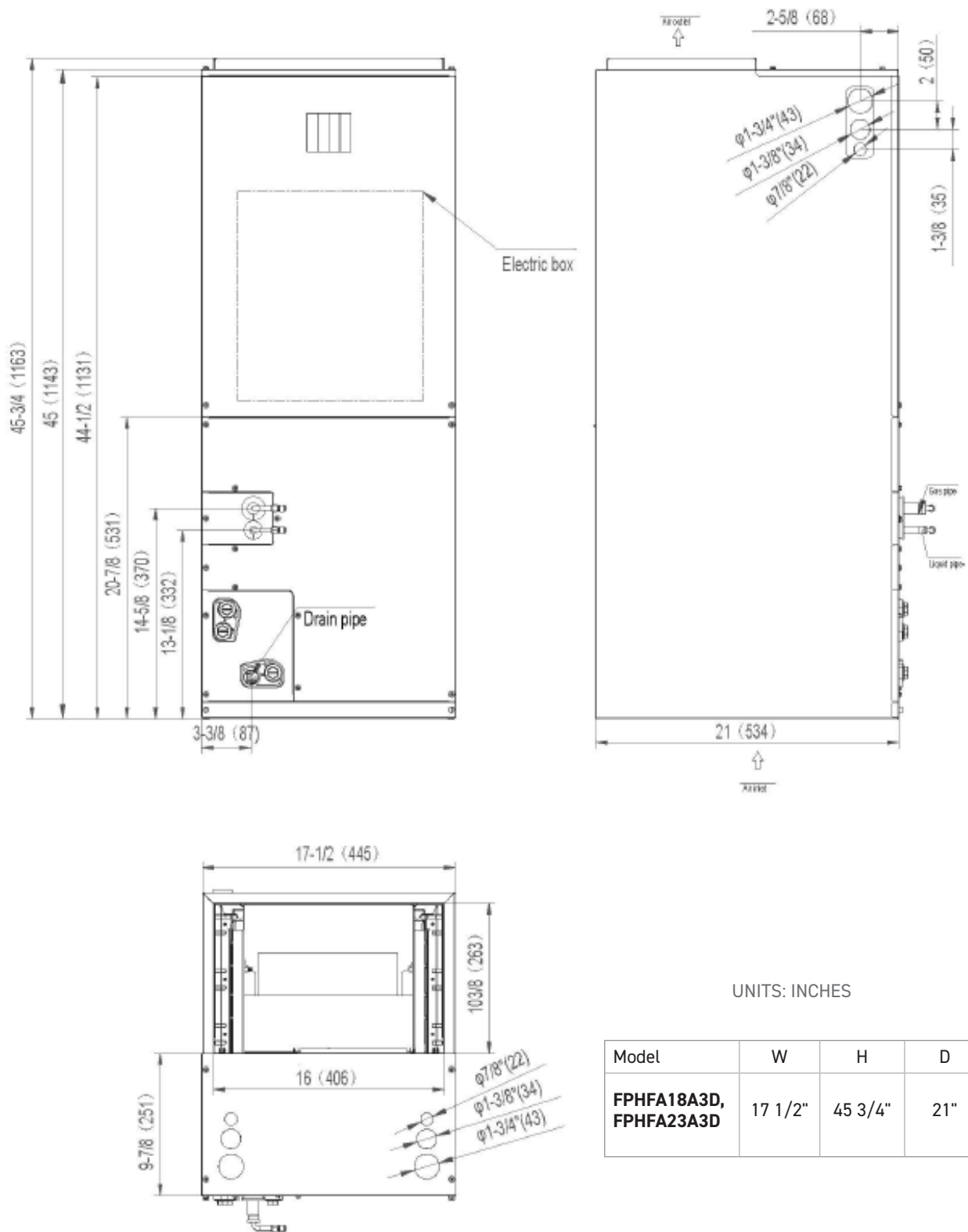

Model	W	H	D
<b>FPHFA18A3D, FPHFA23A3D</b>	17 1/2"	45 3/4"	21"